

AFE77xxD Quad/Dual-Channel RF Transceiver With Dual Feedback Paths Integrating CFR/DPD

1 Features

- Quad (AFE776xD) / Dual (AFE7728D) transmitters based on 0-IF up-conversion architecture:
 - Up to 650 MHz (AFE77x8D) / 730 MHz (AFE7769D) of RF transmitted DPD expansion bandwidth per chain
- Quad (AFE776xD) / Dual (AFE7728D) receivers based on 0-IF down-conversion architecture:
 - Up to 200 MHz (AFE77x8D) / 300 MHz (AFE7769D) of RF received bandwidth per chain
- Feedback chain based on direct RF sampling architecture:
 - Up to 650 MHz (AFE77x8D) / 730 MHz (AFE7769D) of RF observed DPD expansion bandwidth
- Integrated CFR/DPD for PA linearization
 - Up to 200MHz (AFE77x8D) / 300MHz (AFE7769D) instantaneous bandwidth
 - Up to 650MHz (AFE77x8D) / 730MHz (AFE7769D) DPD expansion bandwidth
- Integrated CFR/DPD for PA linearization
 - Multistage CFR with configurable cancelling pulses
 - Hardware accelerated DPD estimation engine
 - Signal Dynamics based corrector for GaN PA linearization
 - Smart data capture
- RF frequency range: 600 MHz to 6 GHz
- Four wideband fractional-N PLL, VCO for TX and RX LO
- Dedicated integer-N PLL, VCO for data converters clock generation
- JESD204B and JESD204C SerDes interface support:
 - 4 SerDes transceivers up to 29.5 Gbps
 - 8b/10b and 64b/66b encoding
 - 16-bit, 12-bit, 24-bit and 32-bit formatting
 - Subclass 1 multi-device synchronization
- Package: 17-mm × 17-mm FCBGA, 0.8-mm pitch

2 Applications

- Macro remote radio unit (RRU)
- Small cell base station
- Active antenna system mMIMO (AAS)
- Distributed Antenna Systems (DAS)
- Repeater

3 Description

The AFE77xxD is a pin-compatible family of high-performance, multichannel transceivers, integrating four (AFE7768D/AFE7769D) or two (AFE7728D) direct up-conversion transmitter chains, four (AFE7768D/AFE7769D) or two (AFE7728D) direct down-conversion receiver chains, two wideband RF sampling digitizing auxiliary chains (feedback paths) and low-power Digital Pre-Distortion (DPD) engine for Power Amplifier (PA) linearization. The high dynamic range of the transmitter and receiver chains enables wireless base stations to transmit and receive 2G, 3G, 4G, and 5G signals. The integrated Crest Factor Reduction (CFR) unit helps reduce the Peak-to-Average Ratio (PAR) of the input signal for more efficient transmission through the Power Amplifier. The integrated hardware accelerated DPD estimator and corrector provides flexible and efficient DPD solution for PA linearization. The integrated DPD engine corrects the distortion due to PA nonlinearity for signals up to 200MHz (AFE77x8D) / 300MHz (AFE7769D) instantaneous bandwidth, and within up to 650MHz (AFE77x8D) / 730MHz (AFE7769D) DPD expanded bandwidth. A dedicated GaN corrector addresses the long-term nonlinear memory effects due to charge trapping of GaN PAs.

The low power dissipation and high density channel integration of the AFE77xxD allow the device to address the power and size constraints of 4G and 5G base stations. The wideband and high dynamic range feedback path can assist the DPD of the power amplifiers in the transmitter chain through smart data capture at various intercepting points. The available 29.5Gbps SerDes speed can help reduce the number of lanes required to transfer the data in and out of the device.

Package Information

PART NUMBER	PACKAGE ⁽¹⁾	PACKAGE SIZE ⁽²⁾
AFE77xxD	ABJ (FCBGA, 400)	17.00 mm × 17.00 mm

- (1) For all available packages, see the orderable addendum at the end of the data sheet.
- (2) The package size (length × width) is a nominal value and includes pins, where applicable.



Each receiver chain of the AFE77xxD includes a 28-dB range digital step attenuator (DSA), followed by a wideband passive IQ demodulator, and a baseband amplifier with integrated antialiasing low pass filters with programmable bandwidth, driving continuous-time sigma-delta ADCs. The RX chain can receive an instantaneous bandwidth (IBW) up to 200 MHz (AFE77x8D) / 300 MHz (AFE7769D). Each receiver channel has two analog peak power detectors and various digital power detectors to assist an external or internal autonomous AGC control for receiver channels, and a RF overload detector for device reliability protection. The integrated QMC (quadrature mismatch compensation) algorithm is capable to continuously monitor and correct for the RX chain I and Q imbalance mismatch without the need to inject any specific signals or perform offline calibration.

Each transmitter chain includes two 14-bit, 3.3-Gsps IQ DACs, followed by a programmable reconstruction and DAC image rejection filter, an IQ modulator driving a wideband RF amplifier with 39-dB range gain control. The TX chain integrated QMC and LO leakage cancellation algorithms, leveraging the FB path can constantly track and correct for the TX chain IQ mismatch and LO leakage.

Each FB path is based on RF sampling architecture, and includes an input RF DSA driving a 14-bit, 3.3-Gsps RF ADC. The direct sampling architecture provides an inherently wideband receiver chain and simplifies the calibration of the TX chains impairments. The FB path integrates two independent NCOs, which allow for a fast switching between two observed RF input bands.

The synthesizer section integrates four fractional-N RF PLLs that can generate four different RF LOs, allowing the device to support up to two different bands, each one configured as two transmitters, two receivers, and one feedback path (with AFE7768D/AFE7769D), or one transmitter, one receiver, and one feedback path (with AFE7728D).

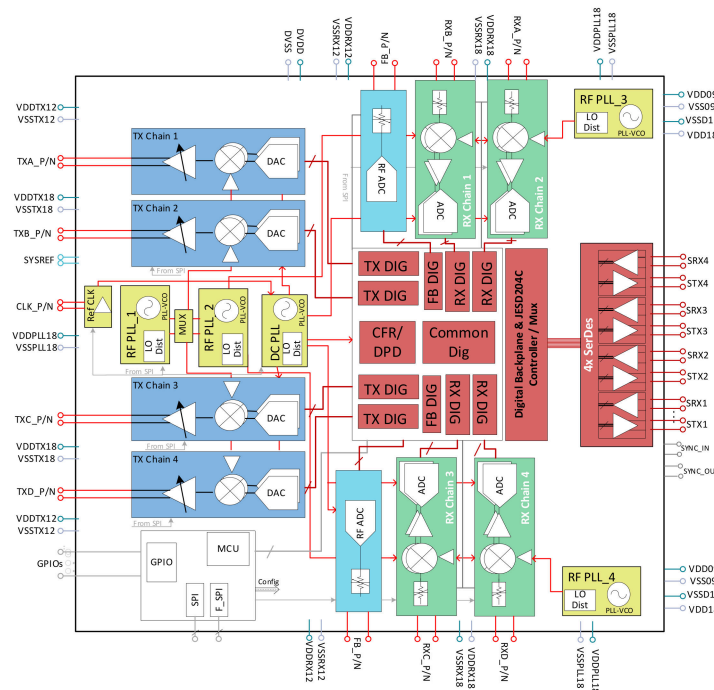

AFE7768D/AFE7769D Block Diagram

Table of Contents

1 Features	1	5.2 Support Resources.....	5
2 Applications	1	5.3 Trademarks.....	5
3 Description	1	5.4 Electrostatic Discharge Caution.....	5
4 Revision History	4	5.5 Glossary.....	5
5 Device and Documentation Support	5	6 Mechanical, Packaging, and Orderable Information	5
5.1 Receiving Notification of Documentation Updates.....	5		

4 Revision History

NOTE: Page numbers for previous revisions may differ from page numbers in the current version.

Changes from Revision * (July 2023) to Revision A (October 2023)	Page
• Changed "Quad" to "Quad (AFE776xD) / Dual (AFE7728D)".....	1

5 Device and Documentation Support

5.1 Receiving Notification of Documentation Updates

To receive notification of documentation updates, navigate to the device product folder on [ti.com](https://www.ti.com). Click on *Subscribe to updates* to register and receive a weekly digest of any product information that has changed. For change details, review the revision history included in any revised document.

5.2 Support Resources

[TI E2E™ support forums](#) are an engineer's go-to source for fast, verified answers and design help — straight from the experts. Search existing answers or ask your own question to get the quick design help you need.

Linked content is provided "AS IS" by the respective contributors. They do not constitute TI specifications and do not necessarily reflect TI's views; see TI's [Terms of Use](#).

5.3 Trademarks

TI E2E™ is a trademark of Texas Instruments.

All trademarks are the property of their respective owners.

5.4 Electrostatic Discharge Caution



This integrated circuit can be damaged by ESD. Texas Instruments recommends that all integrated circuits be handled with appropriate precautions. Failure to observe proper handling and installation procedures can cause damage.

ESD damage can range from subtle performance degradation to complete device failure. Precision integrated circuits may be more susceptible to damage because very small parametric changes could cause the device not to meet its published specifications.

5.5 Glossary

[TI Glossary](#) This glossary lists and explains terms, acronyms, and definitions.

6 Mechanical, Packaging, and Orderable Information

The following pages include mechanical, packaging, and orderable information. This information is the most current data available for the designated devices. This data is subject to change without notice and revision of this document. For browser-based versions of this data sheet, refer to the left-hand navigation.

PACKAGING INFORMATION

Orderable part number	Status (1)	Material type (2)	Package Pins	Package qty Carrier	RoHS (3)	Lead finish/ Ball material (4)	MSL rating/ Peak reflow (5)	Op temp (°C)	Part marking (6)
AFE7728DIABJ	Active	Production	FCBGA (ABJ) 400	90 JEDEC TRAY (5+1)	Yes	SNAGCU	Level-3-260C-168 HR	-40 to 85	AFE7728D
AFE7728DIABJ.B	Active	Production	FCBGA (ABJ) 400	90 JEDEC TRAY (5+1)	Yes	SNAGCU	Level-3-260C-168 HR	-40 to 85	AFE7728D
AFE7768DIABJ	Active	Production	FCBGA (ABJ) 400	90 JEDEC TRAY (5+1)	-	SNAGCU	Level-3-260C-168 HR	-40 to 85	AFE7768D
AFE7768DIABJ.B	Active	Production	FCBGA (ABJ) 400	90 JEDEC TRAY (5+1)	-	SNAGCU	Level-3-260C-168 HR	-40 to 85	AFE7768D
AFE7769DIABJ	Active	Production	FCBGA (ABJ) 400	90 JEDEC TRAY (5+1)	-	SNAGCU	Level-3-260C-168 HR	-40 to 85	AFE7769D
AFE7769DIABJ.B	Active	Production	FCBGA (ABJ) 400	90 JEDEC TRAY (5+1)	-	SNAGCU	Level-3-260C-168 HR	-40 to 85	AFE7769D

(1) **Status:** For more details on status, see our [product life cycle](#).

(2) **Material type:** When designated, preproduction parts are prototypes/experimental devices, and are not yet approved or released for full production. Testing and final process, including without limitation quality assurance, reliability performance testing, and/or process qualification, may not yet be complete, and this item is subject to further changes or possible discontinuation. If available for ordering, purchases will be subject to an additional waiver at checkout, and are intended for early internal evaluation purposes only. These items are sold without warranties of any kind.

(3) **RoHS values:** Yes, No, RoHS Exempt. See the [TI RoHS Statement](#) for additional information and value definition.

(4) **Lead finish/Ball material:** Parts may have multiple material finish options. Finish options are separated by a vertical ruled line. Lead finish/Ball material values may wrap to two lines if the finish value exceeds the maximum column width.

(5) **MSL rating/Peak reflow:** The moisture sensitivity level ratings and peak solder (reflow) temperatures. In the event that a part has multiple moisture sensitivity ratings, only the lowest level per JEDEC standards is shown. Refer to the shipping label for the actual reflow temperature that will be used to mount the part to the printed circuit board.

(6) **Part marking:** There may be an additional marking, which relates to the logo, the lot trace code information, or the environmental category of the part.

Multiple part markings will be inside parentheses. Only one part marking contained in parentheses and separated by a "~" will appear on a part. If a line is indented then it is a continuation of the previous line and the two combined represent the entire part marking for that device.

Important Information and Disclaimer: The information provided on this page represents TI's knowledge and belief as of the date that it is provided. TI bases its knowledge and belief on information provided by third parties, and makes no representation or warranty as to the accuracy of such information. Efforts are underway to better integrate information from third parties. TI has taken and continues to take reasonable steps to provide representative and accurate information but may not have conducted destructive testing or chemical analysis on incoming materials and chemicals. TI and TI suppliers consider certain information to be proprietary, and thus CAS numbers and other limited information may not be available for release.

In no event shall TI's liability arising out of such information exceed the total purchase price of the TI part(s) at issue in this document sold by TI to Customer on an annual basis.

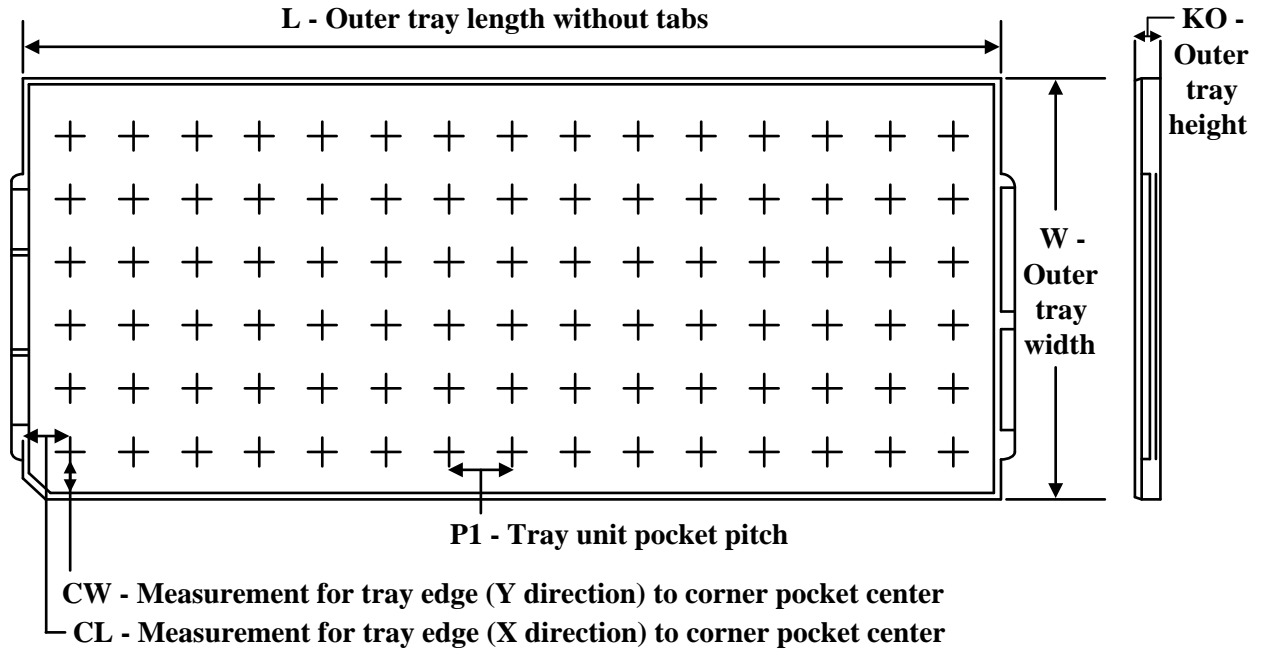
TRAY

Chamfer on Tray corner indicates Pin 1 orientation of packed units.

*All dimensions are nominal

Device	Package Name	Package Type	Pins	SPQ	Unit array matrix	Max temperature (°C)	L (mm)	W (mm)	K0 (µm)	P1 (mm)	CL (mm)	CW (mm)
AFE7728DIABJ	ABJ	FCBGA	400	90	6 x 15	150	315	135.9	7620	19.5	21	19.2
AFE7728DIABJ.B	ABJ	FCBGA	400	90	6 x 15	150	315	135.9	7620	19.5	21	19.2
AFE7768DIABJ	ABJ	FCBGA	400	90	6 x 15	150	315	135.9	7620	19.5	21	19.2
AFE7768DIABJ.B	ABJ	FCBGA	400	90	6 x 15	150	315	135.9	7620	19.5	21	19.2
AFE7769DIABJ	ABJ	FCBGA	400	90	6 x 15	150	315	135.9	7620	19.5	21	19.2
AFE7769DIABJ.B	ABJ	FCBGA	400	90	6 x 15	150	315	135.9	7620	19.5	21	19.2

ABJ0400A

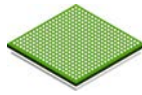

PACKAGE OUTLINE

FCBGA - 2.65 mm max height

BALL GRID ARRAY

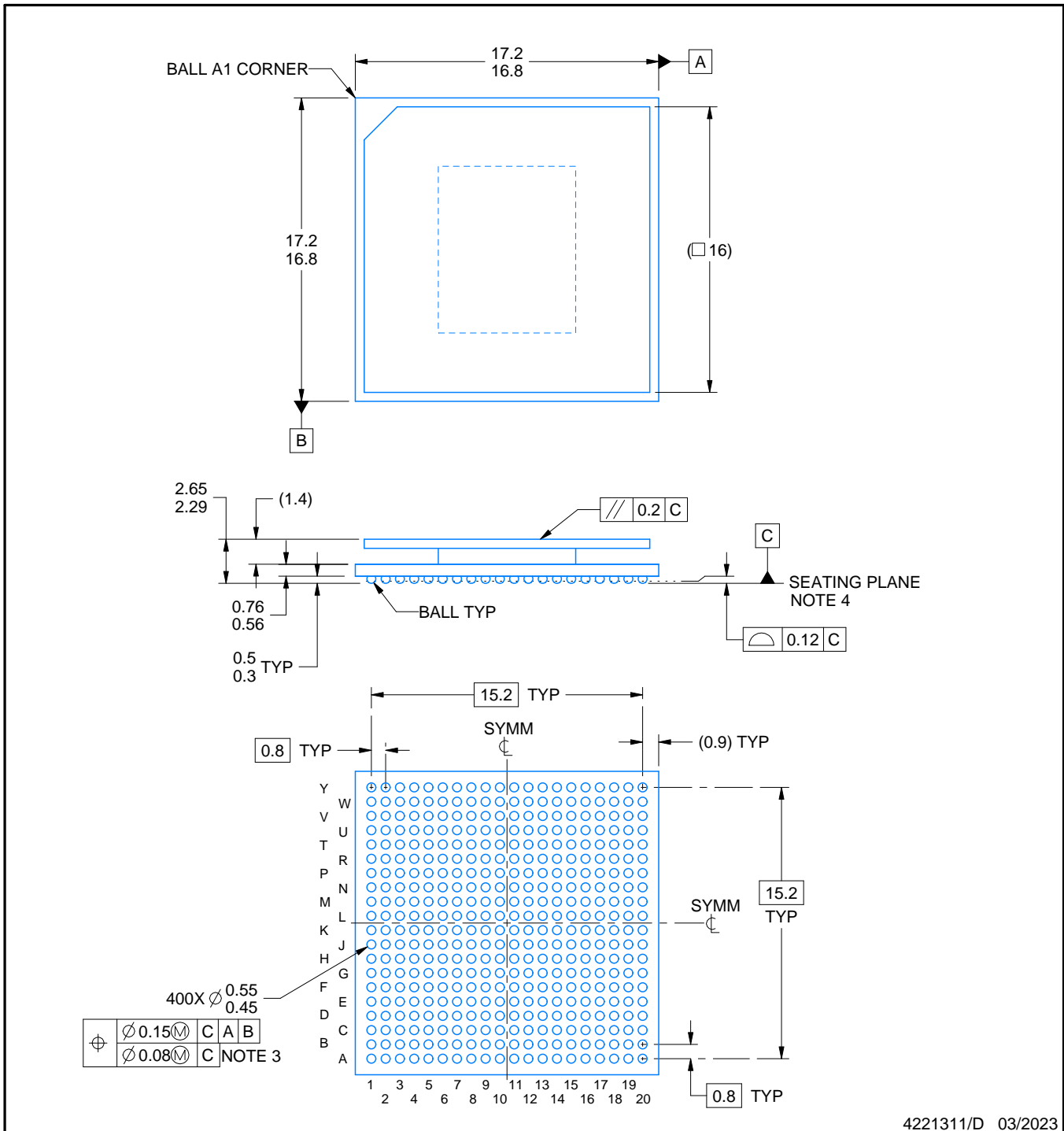

4221311/D 03/2023

NOTES:

1. All linear dimensions are in millimeters. Any dimensions in parenthesis are for reference only. Dimensioning and tolerancing per ASME Y14.5M.
2. This drawing is subject to change without notice.
3. Dimension is measured at the maximum solder ball diameter, parallel to primary datum C.
4. Primary datum C and seating plane are defined by the spherical crowns of the solder balls.
5. The lids are electrically floating (e.g. not tied to GND).

EXAMPLE BOARD LAYOUT

ABJ0400A

FCBGA - 2.65 mm max height

BALL GRID ARRAY

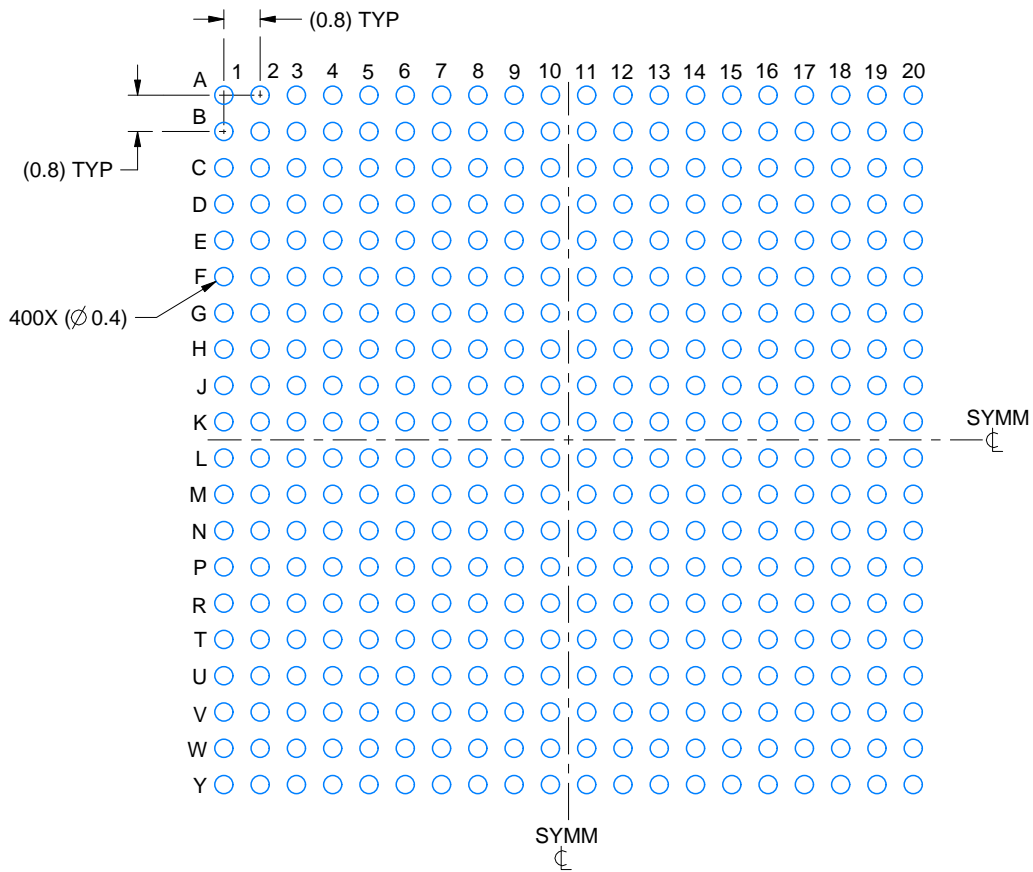

LAND PATTERN EXAMPLE
EXPOSED METAL SHOWN
SCALE:6X

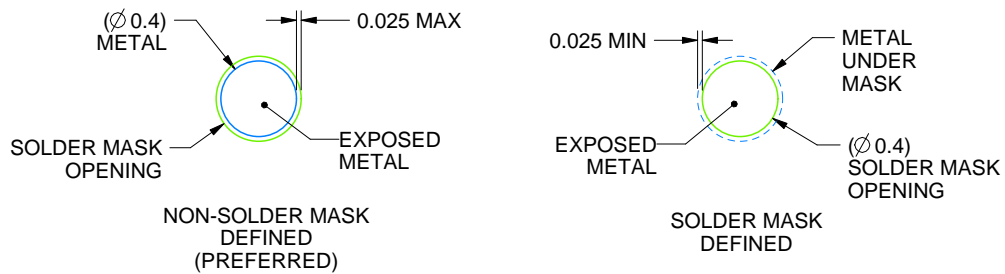

SOLDER MASK DETAILS
NOT TO SCALE

4221311/D 03/2023

NOTES: (continued)

- Final dimensions may vary due to manufacturing tolerance considerations and also routing constraints. For more information, see Texas Instruments literature number SPRU811 (www.ti.com/lit/spru811).

EXAMPLE STENCIL DESIGN

ABJ0400A

FCBGA - 2.65 mm max height

BALL GRID ARRAY

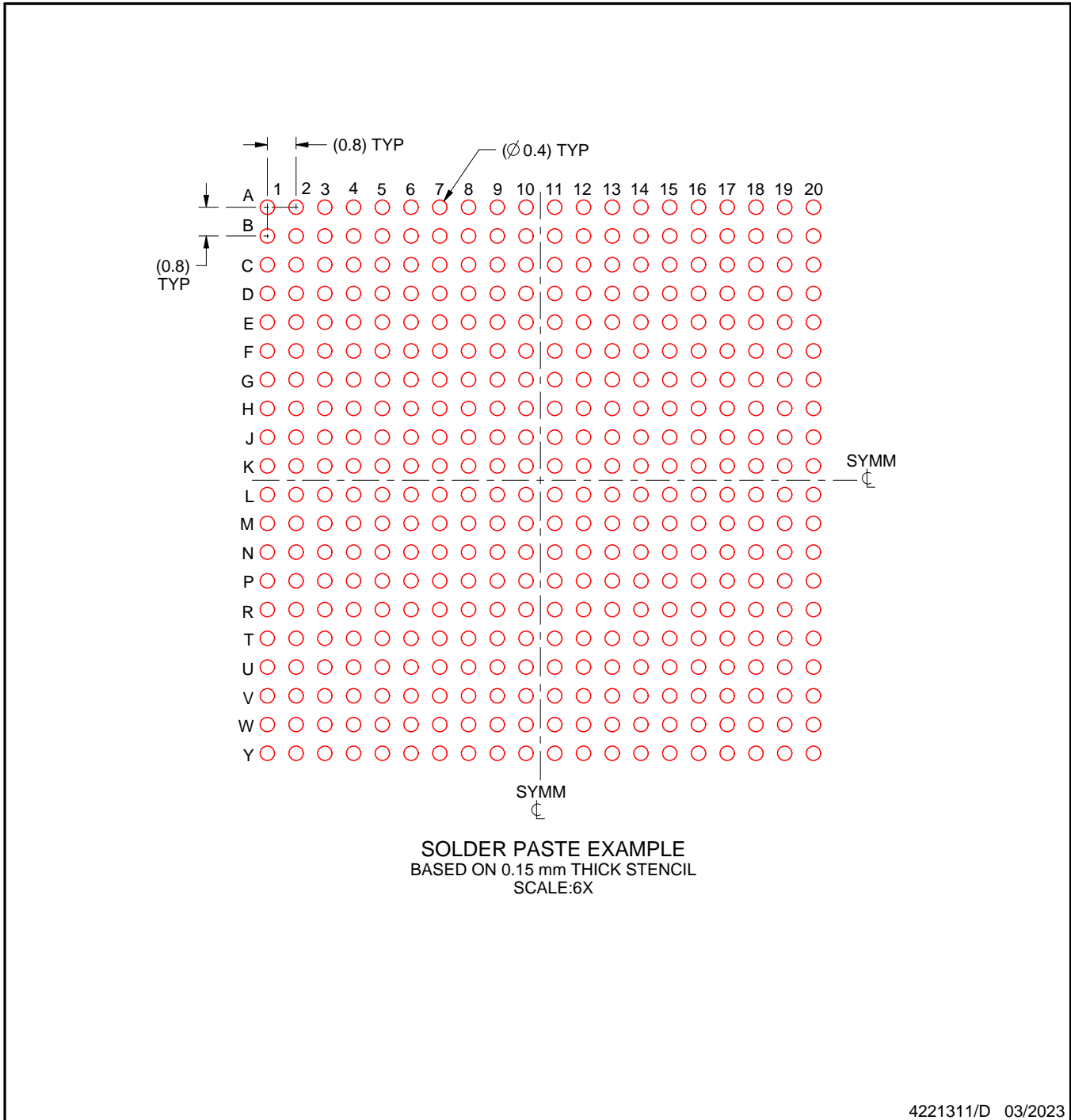

NOTES: (continued)

7. Laser cutting apertures with trapezoidal walls and rounded corners may offer better paste release.

IMPORTANT NOTICE AND DISCLAIMER

TI PROVIDES TECHNICAL AND RELIABILITY DATA (INCLUDING DATASHEETS), DESIGN RESOURCES (INCLUDING REFERENCE DESIGNS), APPLICATION OR OTHER DESIGN ADVICE, WEB TOOLS, SAFETY INFORMATION, AND OTHER RESOURCES "AS IS" AND WITH ALL FAULTS, AND DISCLAIMS ALL WARRANTIES, EXPRESS AND IMPLIED, INCLUDING WITHOUT LIMITATION ANY IMPLIED WARRANTIES OF MERCHANTABILITY, FITNESS FOR A PARTICULAR PURPOSE OR NON-INFRINGEMENT OF THIRD PARTY INTELLECTUAL PROPERTY RIGHTS.

These resources are intended for skilled developers designing with TI products. You are solely responsible for (1) selecting the appropriate TI products for your application, (2) designing, validating and testing your application, and (3) ensuring your application meets applicable standards, and any other safety, security, regulatory or other requirements.

These resources are subject to change without notice. TI grants you permission to use these resources only for development of an application that uses the TI products described in the resource. Other reproduction and display of these resources is prohibited. No license is granted to any other TI intellectual property right or to any third party intellectual property right. TI disclaims responsibility for, and you fully indemnify TI and its representatives against any claims, damages, costs, losses, and liabilities arising out of your use of these resources.

TI's products are provided subject to [TI's Terms of Sale](#), [TI's General Quality Guidelines](#), or other applicable terms available either on ti.com or provided in conjunction with such TI products. TI's provision of these resources does not expand or otherwise alter TI's applicable warranties or warranty disclaimers for TI products. Unless TI explicitly designates a product as custom or customer-specified, TI products are standard, catalog, general purpose devices.

TI objects to and rejects any additional or different terms you may propose.

Copyright © 2025, Texas Instruments Incorporated

Last updated 10/2025

Looking for pricing, stock, or lifecycle information?

Click below to explore more details on WIN SOURCE:

 [View AFE7728DIABJ on WIN SOURCE](#)

 [Texas Instruments](#) Information

Optimize Your Supply Chain with WIN SOURCE Solutions

-  Global Sourcing Solution
-  Obsolete Management
-  Cost Control Management
-  Shortage Management
-  Alternative Solution
-  Excess Inventory Management