

### Product Overview

The QPC3025 is a Silicon on Insulator (SOI) single-pole, double-throw (SPDT) switch, designed for use in 4G/5G wireless infrastructure applications and other high-performance communications systems. It offers low insertion loss in a symmetric topology with excellent linearity. The switch can handle up to 20W CW and 30W pulsed power with 50 Ohm load. No blocking capacitors are necessary on the RF ports. The switch ports are reflective. The QPC3025 is +1.8V logic compatible and has a single-pin solution to disable the Negative Voltage Generator and supply negative voltage from off-chip, if necessary.

The QPC3025 is packaged in a RoHS-compliant, compact 5x5 mm surface-mount leadless package.

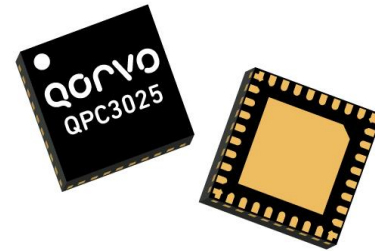

32 Pin 5 mm x 5 mm leadless SMT Package

### Functional Block Diagram

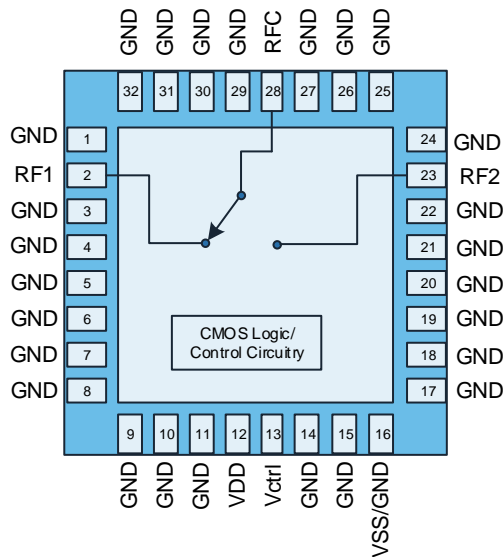

Top View

### Key Features

- 30 MHz to 4200 MHz Operation
- Symmetric Switch Structure
- 0.35dB Insertion Loss at 2 GHz
- Power Handling: 30W pulsed power  
20W CW
- 39 dB High Isolation at 2 GHz
- +1.8 V Logic Compatible
- +2.7 V to +5.5 V Single DC Supply

### Applications

- Repeaters/Boosters
- Test and Measurement Equipment

### Ordering Information

Part No.	Description
QPC3025TR13	2500 pcs on a 13" reel
QPC3025EVB-01	Evaluation board

## Absolute Maximum Ratings

Parameter	Rating
Storage Temperature	-50 to 150 °C
VDD	+6 V
V <sub>CTRL</sub>	-0.3V to +6V
Pin, 80-2000 MHz	45.5 dBm
Pin, 2000-2700 MHz	45 dBm
Pin, 2700-4200 MHz	44 dBm

Operation of this device outside the parameter ranges given above may cause permanent damage.

## Recommended Operating Conditions

Parameter	Min	Typ	Max	Units
VDD	+2.7	+5.0	+5.50	V
VSS, (Internal NVG disabled)	-5.5	-5.0	-3.15	V
Pin (RFC – RFX), CW, 50 Ω			43	dBm
Pin Hot-Switching, CW, 50 Ω			15	dBm
Pin (RFC – RFX) Pulsed with 10% DC 5ms period, 50 Ω	80-2000 MHz		45	dBm
	2000-2700 MHz		44.5	dBm
	2700-4200 MHz		43.5	dBm
T <sub>CASE</sub>	-40		+85	°C
T <sub>j</sub> at MTTF>10 <sup>5</sup> hrs.			+125	°C

Electrical specifications are measured at specified test conditions. Specifications are not guaranteed over all recommended operating conditions.

## Electrical Specifications

Test conditions, unless otherwise noted: Temp = 25°C, VDD = +5V.

Parameter	Conditions	Min	Typ	Max	Units
Operational Frequency Range		30		4200	MHz
Insertion Loss <sup>(1)</sup>	30 – 1000 MHz		0.35		dB
	1000 – 2000 MHz		0.35		dB
	2000 – 3000 MHz		0.39		dB
	3000 – 4200 MHz		0.41		dB
Isolation, RFC-RFX <sup>(1)</sup>	30 – 1000 MHz		46		dB
	1000 – 2000 MHz		38.5		dB
	2000 – 3000 MHz		35		dB
	3000 – 4200 MHz		29		dB
Isolation, RFX-RFX <sup>(1)</sup>	30 – 1000 MHz		47.5		dB
	1000 – 2000 MHz		40		dB
	2000 – 3000 MHz		36		dB
	3000 – 4200 MHz		30		dB
Return Loss, RFC	30 – 1000 MHz		33		dB
	1000 – 2000 MHz		25		dB
	2000 – 3000 MHz		23		dB
	3000 – 4200 MHz		22		dB
Return Loss, RFX	30 – 1000 MHz		35		dB
	1000 – 2000 MHz		25		dB
	2000 – 3000 MHz		23		dB
	3000 – 4200 MHz		25		dB
Input P <sub>0.1dB</sub> <sup>(2)</sup>	80 – 2000 MHz		+45.5		dBm
	2000 – 2700 MHz		+45		dBm
	2700 – 4200 MHz		+44		dBm
Input IP3	RFC-RFX, 2000 MHz, 32dBm/tone, 1MHz Δf		74		dBm
Harmonics	2F <sub>0</sub> , F <sub>0</sub> = 1GHz at +45dBm Pulsed power (10% DC, 5ms period)		-90		dBc
	3F <sub>0</sub> , F <sub>0</sub> = 1GHz at +45dBm Pulsed power (10% DC, 5ms period)		-87		dBc

Notes:

1. Production screening tests are done at 1000MHz and 2000MHz.
2. This is just a linearity figure of merit. Refer to 'Recommended Operating Conditions' table for Pin levels

## Electrical Specifications (continued)

Test conditions, unless otherwise noted: Temp = 25°C, VDD = +5V.

Parameter	Conditions	Min	Typ	Max	Units
Harmonics	2F <sub>0</sub> , F <sub>0</sub> = 1GHz at +45dBm Pulsed power (10% DC, 5ms period)		-90		dBc
	3F <sub>0</sub> , F <sub>0</sub> = 1GHz at +45dBm Pulsed power (10% DC, 5ms period)		-87		dBc
Switching Time	Turn-on, (50% V <sub>CTRL</sub> to 90% RF)		5.8		μs
	Turn-off, (50% V <sub>CTRL</sub> to 10% RF)		4.7		μs
Settling Time	50% V <sub>CTRL</sub> until harmonics settle to steady-state value		8.58		μs
Dead Time	Time required from 50% V <sub>CTRL</sub> (no RF) to applying RF, RF power > +15dBm, T <sub>CASE</sub> -40°C to +85°C		7		μs
Supply Current, I <sub>DD</sub>	VDD = +5V		90	200	μA
Control Voltage, V <sub>CTRL</sub>	V <sub>IH</sub>	1.17	1.80	V <sub>DD</sub>	V
	V <sub>IL</sub>	0		0.63	V
Control Current, I <sub>CTRL</sub>			2		μA
Negative Supply Current, I <sub>SS</sub>	Pin 16, V <sub>SS</sub> = -5V		-100		μA
Spur Level <sup>(3)</sup>	Any RF ports, V <sub>SS</sub> = 0V, NVG ON		-115		dBm
Thermal Resistance			17		°C/W

Notes:

3. If spur-free performance is desired the internal NVG can be disabled by supplying an external negative voltage at pin 16.

## Logic Table

Vctrl	Switch path
0	RFC-RF2
1	RFC-RF1

## Switch Timing Diagrams

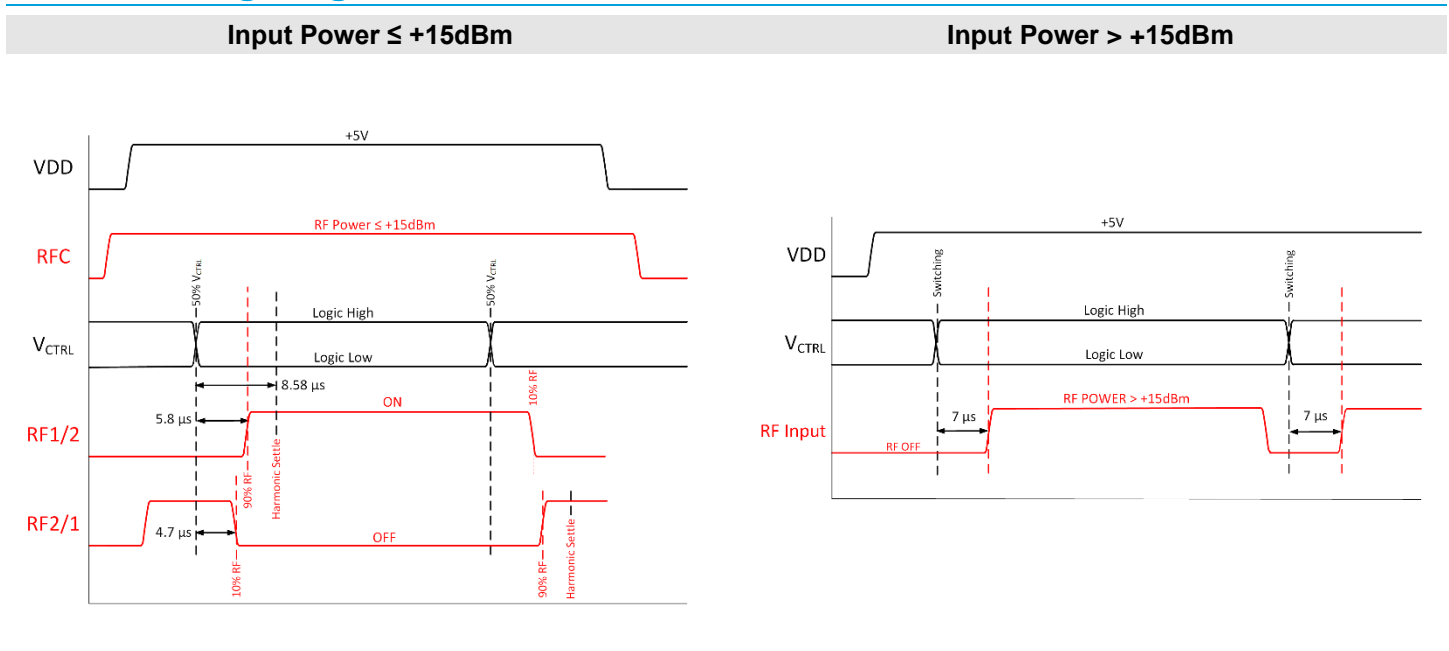

No time marked means no restriction or undefined

**Evaluation Board, QPC3025EVB-01**

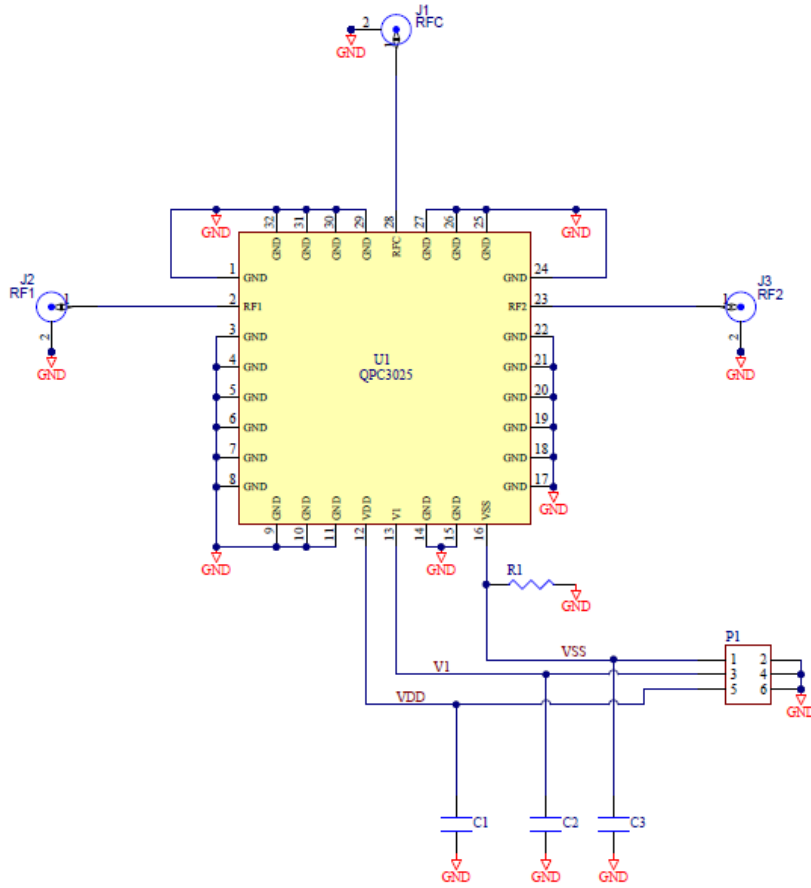

Schematic

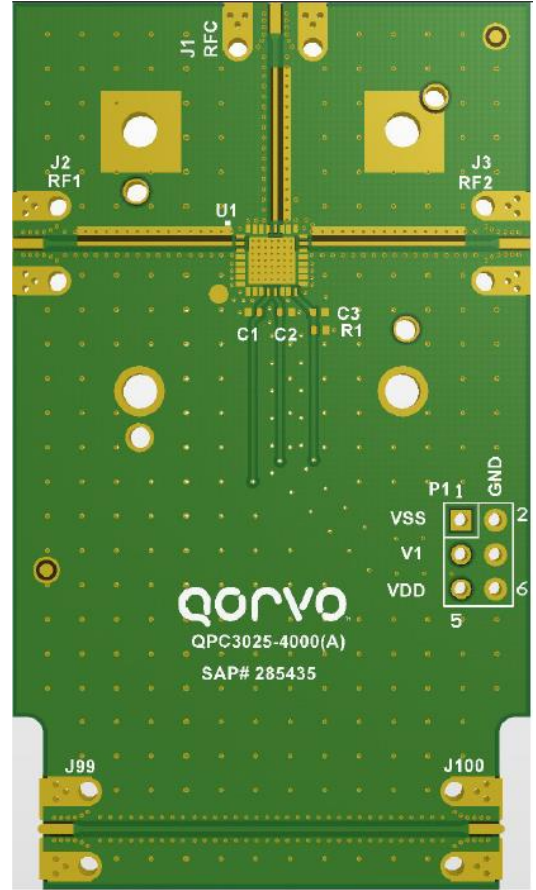

Layout

**Bill of Material**

Ref Des	Value	Description	Manuf.	Part Number
-	-	Printed Circuit Board	Qorvo	
U1	-	High Power SPDT Switch	Qorvo	QPC3025
C1	0.1 $\mu$ F	CAP, 0.1 $\mu$ F, 50V, 10%, X7R,0402	Various	
C2	100 pF	CAP, 100 pF, 50V, 10%,0402	Various	
R1	1 M $\Omega$	RES, 1 M $\Omega$ , 5%, 1/16W, 0402	Various	

**Performance Plots**

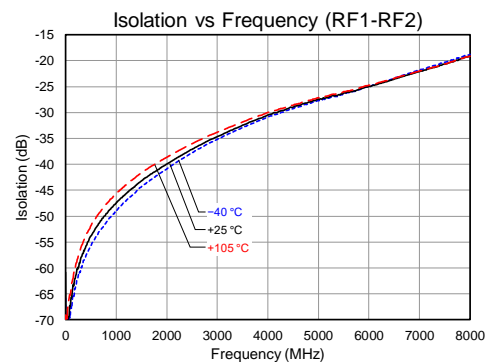
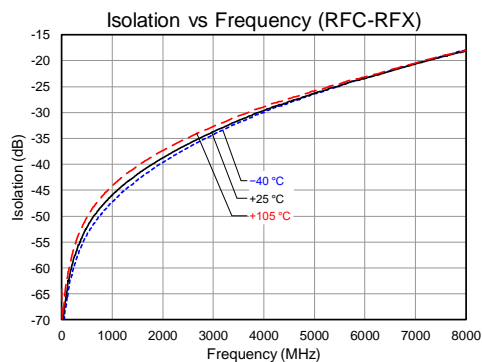
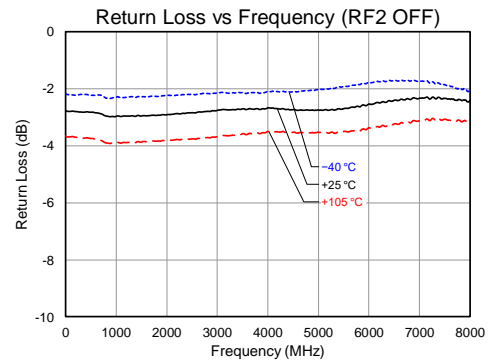
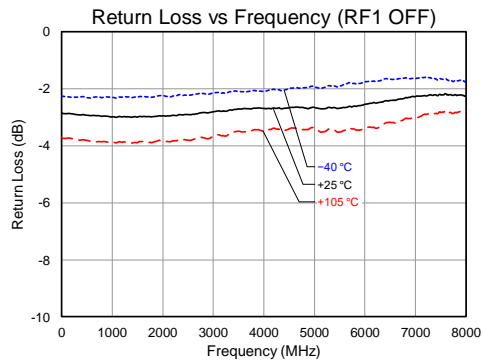
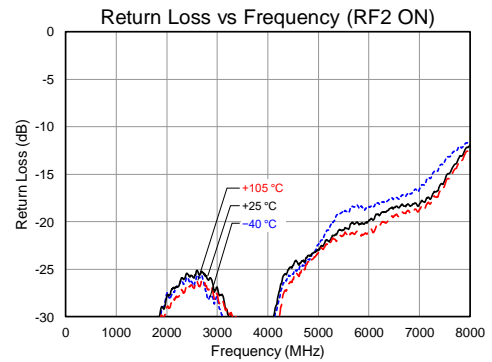
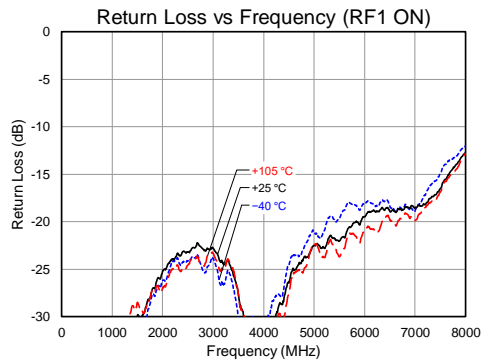
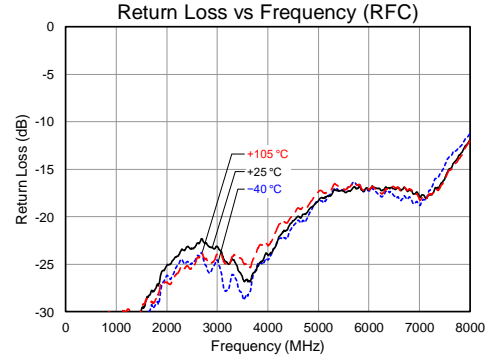
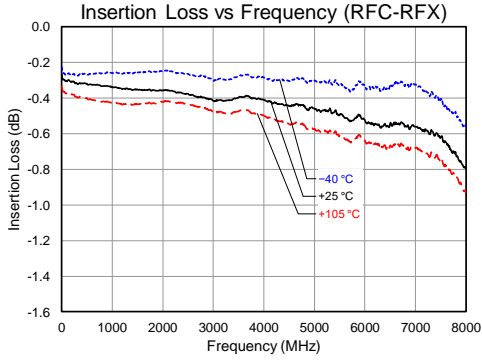

## Pin Configuration and Description

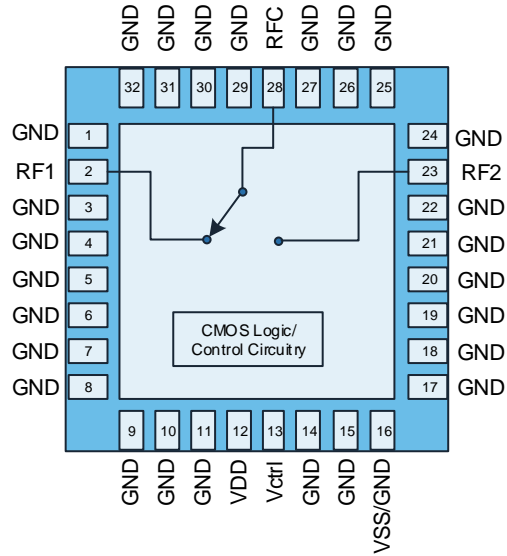

Top View

Pin No.	Label	Description
1,3,4,5,6,7,8,9,10,11,14,15,17,18,19,20,21,22,24,25,26,29,31,32	GND	No internal connection but recommend to ground on board for proper mounting integrity.
27,30	GND	Internally connected and must be grounded on board.
2	RF1	Switch output port 1. Internally at 0V DC.
28	RFC	Switch common port. Internally at 0V DC.
23	RF2	Switch output port 2. Internally at 0V DC.
13	V <sub>CTRL</sub>	Switch control voltage
12	VDD	Supply voltage. Bypassing recommended.
16	VSS/GND	Negative Voltage Generator (NVG) control pin. Supply GND (Low inductive path to ground) to enable internal NVG or supply -3.3 V to -5.5 V to disable internal NVG. Once disabled, internal NVG cannot be enabled without cycling VDD.
Backside Pad	GND	Ground connection. The back side of the package should be soldered to a good ground pad with enough vias for thermal dissipation and RF/DC ground path.

## Package Marking and Dimensions

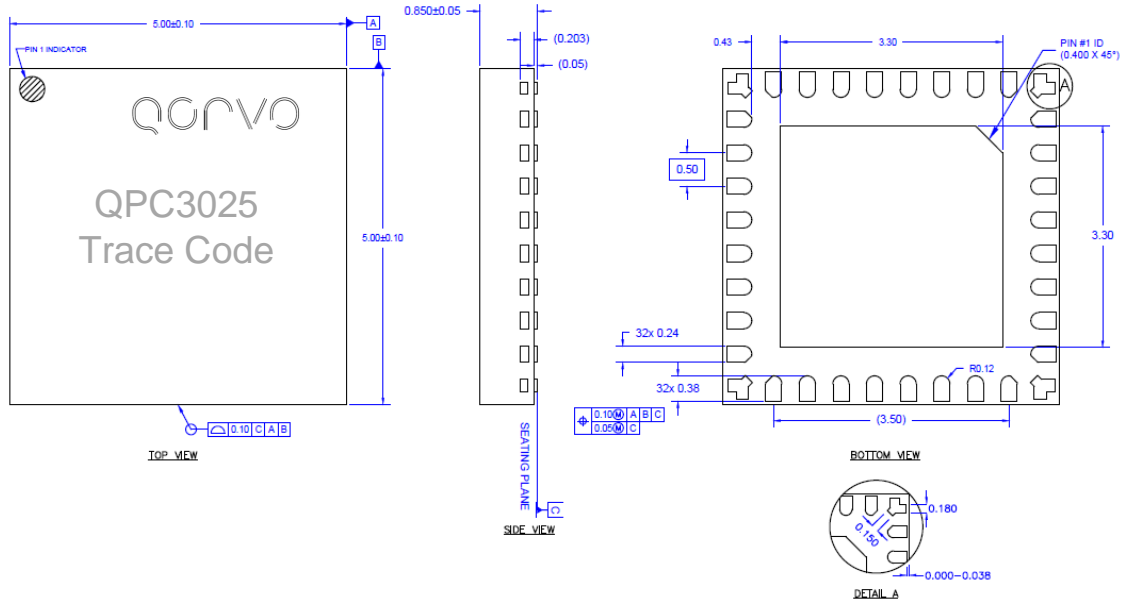

**Notes:**

1. All dimensions are in microns. Angles are in degrees.
2. Dimension and tolerance formats conform to ASME Y14.4M-1994.
3. The terminal #1 identifier and terminal numbering conform to JESD 95-1 SPP-012.

## PCB Mounting Pattern

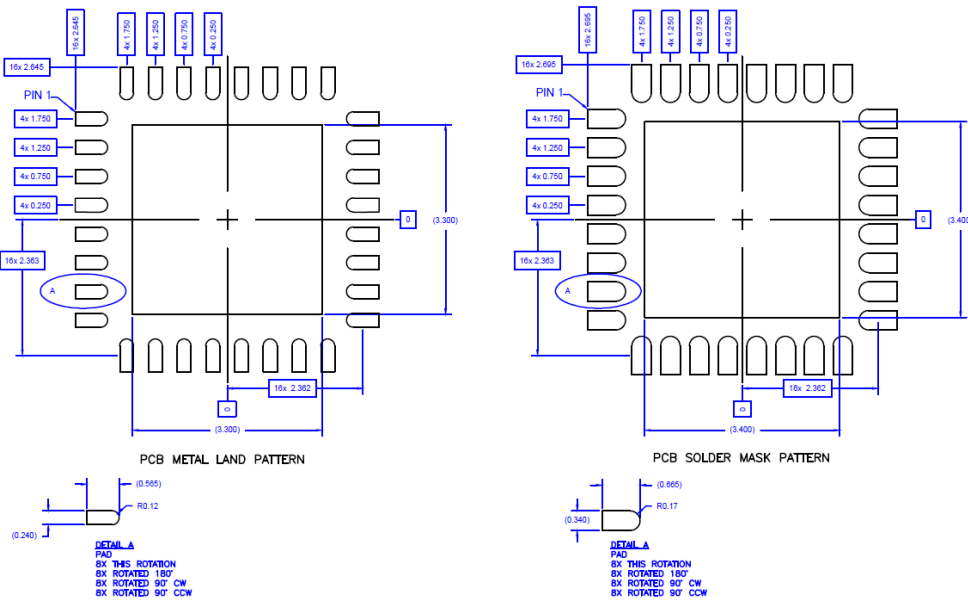

**Notes:**

1. All dimensions are in millimeters. Angles are in degrees.
2. Use 1 oz. copper minimum for top and bottom layer metal.
3. Via holes are required under the backside paddle of this device for proper RF/DC grounding and thermal dissipation.
4. Recommend a 0.35mm (#80/.0135") diameter bit for drilling via holes and a final plated thru diameter of 0.25 mm (0.010").
5. Ensure good package backside paddle solder attach for reliable operation and best electrical performance.



**Tape and Reel Information – Reel Dimensions (13")**

Standard T/R size = 1,000 pieces on a 13" reel.

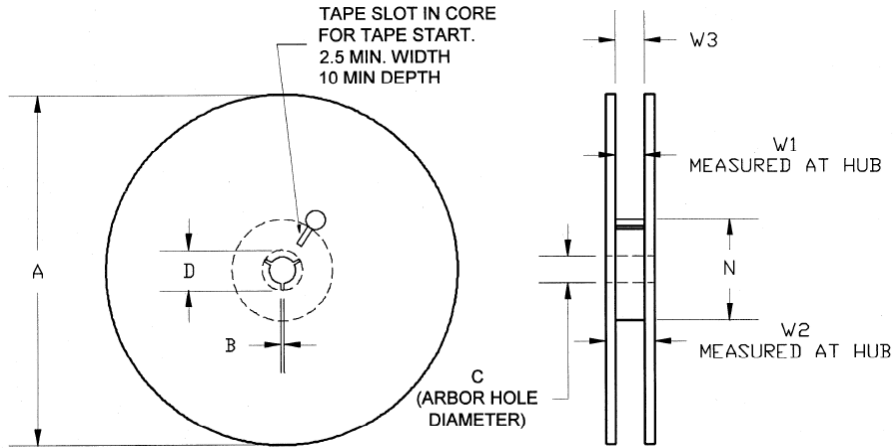

Feature	Measure	Symbol	Size (in)	Size (mm)
Flange	Diameter	A	12.992	330.0
	Thickness	W2	0.717	18.2
	Space Between Flange	W1	0.504	12.8
Hub	Outer Diameter	N	4.016	102.0
	Arbor Hole Diameter	C	0.512	13.0
	Key Slit Width	B	0.079	2.0
	Key Slit Diameter	D	0.787	20.0

**Tape and Reel Information – Tape Length and Label Placement**

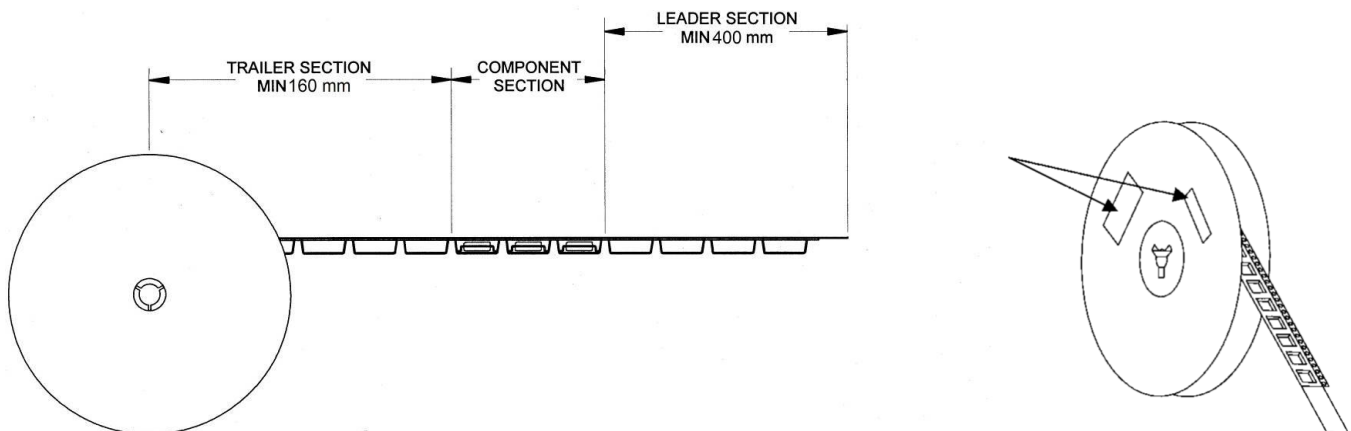

- Notes:
1. Empty part cavities at the trailing and leading ends are sealed with cover tape. See EIA 481-1-A.
  2. Labels are placed on the flange opposite the sprockets in the carrier tape.

## Handling Precautions

Parameter	Rating	Standard
ESD – Human Body Model (HBM)	Class 2	ESDA / JEDEC JS-001-2012
ESD – Charged Device Model (CDM)	Class C3	JEDEC JESD22-C101F
MSL – Moisture Sensitivity Level	Level 1	IPC/JEDEC J-STD-020



Caution!  
 ESD-Sensitive Device

## Solderability

Compatible with both lead-free (260°C max. reflow temp.) and tin/lead (245°C max. reflow temp.) soldering processes. Solder profiles available upon request.

Contact plating: NiPdAu

## RoHS Compliance

This part is compliant with 2011/65/EU RoHS directive (Restrictions on the Use of Certain Hazardous Substances in Electrical and Electronic Equipment) as amended by Directive 2015/863/EU.

This product also has the following attributes:

- Lead Free
- Halogen Free (Chlorine, Bromine)
- Antimony Free
- TBBP-A (C<sub>15</sub>H<sub>12</sub>Br<sub>4</sub>O<sub>2</sub>) Free
- PFOS Free
- SVHC Free



## Contact Information

For the latest specifications, additional product information, worldwide sales and distribution locations:

**Web:** [www.qorvo.com](http://www.qorvo.com)

**Tel:** 1-844-890-8163

**Email:** [customer.support@qorvo.com](mailto:customer.support@qorvo.com)

## Important Notice

The information contained herein is believed to be reliable; however, Qorvo makes no warranties regarding the information contained herein and assumes no responsibility or liability whatsoever for the use of the information contained herein. All information contained herein is subject to change without notice. Customers should obtain and verify the latest relevant information before placing orders for Qorvo products. The information contained herein or any use of such information does not grant, explicitly or implicitly, to any party any patent rights, licenses, or any other intellectual property rights, whether with regard to such information itself or anything described by such information. **THIS INFORMATION DOES NOT CONSTITUTE A WARRANTY WITH RESPECT TO THE PRODUCTS DESCRIBED HEREIN, AND QORVO HEREBY DISCLAIMS ANY AND ALL WARRANTIES WITH RESPECT TO SUCH PRODUCTS WHETHER EXPRESS OR IMPLIED BY LAW, COURSE OF DEALING, COURSE OF PERFORMANCE, USAGE OF TRADE OR OTHERWISE, INCLUDING THE IMPLIED WARRANTIES OF MERCHANTABILITY AND FITNESS FOR A PARTICULAR PURPOSE.**

Without limiting the generality of the foregoing, Qorvo products are not warranted or authorized for use as critical components in medical, life-saving, or life-sustaining applications, or other applications where a failure would reasonably be expected to cause severe personal injury or death.

Copyright 2022 © Qorvo, Inc. | Qorvo is a registered trademark of Qorvo, Inc.

## Looking for pricing, stock, or lifecycle information?

Click below to explore more details on WIN SOURCE:

 [View QPC3025TR13 on WIN SOURCE](#)

 [Qorvo US Inc. Information](#)

## Optimize Your Supply Chain with WIN SOURCE Solutions

-  Global Sourcing Solution
-  Obsolete Management
-  Cost Control Management
-  Shortage Management
-  Alternative Solution
-  Excess Inventory Management