

General Description

The QPC8010Q is a single-pole double-throw (SPDT) switch designed for applications requiring very low insertion loss and high power handling capability. The excellent linearity performance of the QPC8010Q makes it ideal for use in many applications. This switch is ideally suited for use in automotive applications. The QPC8010Q is packaged in a compact 2mmx2mm x 0.55mm, 12-pin QFN package.

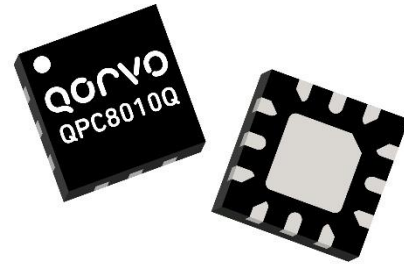

QFN, 12-Pin, 2mm x 2mm x 0.55mm

Functional Block Diagram

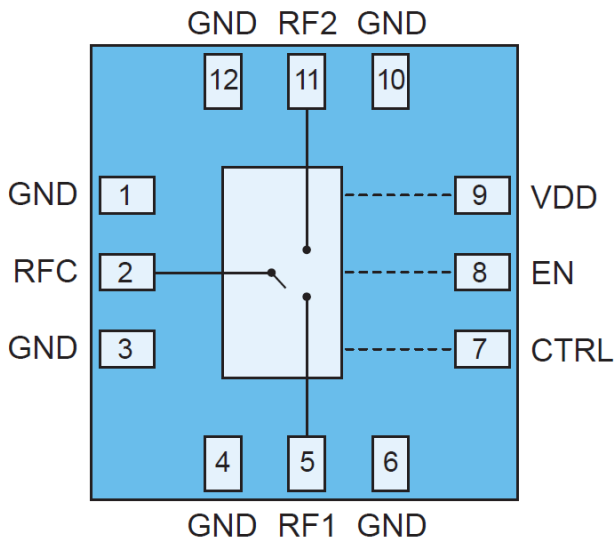

Product Features

- Tested in accordance to AEC-Q100 Grade 2
- 5MHz to 6000MHz Operation
- 50Ω Applications
- Low Insertion Loss: 0.30dB at 1980MHz
- High Isolation: 35dB at 2GHz
- High IP3: >75dBm at 2GHz
- Compatible with Low Voltage Logic (VHIGH Min = 1.3V)
- No External DC Blocking Capacitors Required on RF Paths Unless DC is Applied Externally

Applications

- Antenna switching for e-call
- Automotive CATV, SATV Applications
- Post PA Switching
- General Purpose Automotive Switching Applications

Ordering Information

Part No.	Description
QPC8010QSB	5 piece sample bag
QPC8010QSQ	25 piece sample bag
QPC8010QSR	100 piece sample reel
QPC8010QTR7	2500 piece 7" reel
QPC8010QPCK401	Fully assembled evaluation board + 5 piece sample bag

Absolute Maximum Ratings

Parameter	Rating
Maximum VDD	6.0V
Maximum EN	3.0V
Maximum CTRL	3.0V
Hot-Switching Max Input Power (50Ω load)	20dBm
Max Input Power	31dBm: 5MHz to 25MHz, 50Ω load 34dBm: 25MHz to 500MHz, 50 Ω load 37dBm: >500MHz, 50Ω load 36dBm: >500MHz, 6:1 VSWR
Operating Temperature (TCASE)	-40 to +105 °C
Storage Temperature	-40 to +150 °C
ESD Rating (HBM)	Class 2
ESD Rating (CDM)	Class C3
Moisture Sensitivity Level	MSL-1

Exceeding any one or a combination of the Absolute Maximum Rating conditions may cause permanent damage to the device. Extended application of Absolute Maximum Rating conditions to the device may reduce device reliability.

Electrical Specifications

DC/Control	Conditions ^(1,2)	Min	Typ	Max	Units
Device Voltage, VDD		2.7	3	4.6	V
Leakage Current, IDD	EN = High		100	200	μA
	EN = Low		14	20	μA
Control Voltage (EN, CTRL)	EN = High	1.3	1.8	2.7	V
	EN = Low		0	0.45	V
Control Current	CTRL = High, EN = High		2.5		μA
	CTRL = Low, EN = High		1		μA
Switching Speed (T _{ON} , T _{OFF})	50% Control to 10/90% RF		2	5	μs



Electrical Specifications

Parameter	Conditions ^(1,2)	Min	Typ	Max	Units
Operational Frequency Range		5		6000	MHz
Insertion Loss (RFC to RF1/RF2)	915MHz		0.25	0.45	dB
	1980MHz		0.30	0.60	dB
	2650MHz		0.40	0.65	dB
	5850MHz		0.90	1.45	dB
Isolation (RFC to RF1/RF2)	915MHz	33	40		dB
	1980MHz	28	35		dB
	2650MHz	23	32		dB
	5850MHz	16	21		dB
Isolation (RF1 to RF2)	915MHz		39		dB
	1980MHz		34		dB
	2650MHz		31		dB
	5850MHz		20		dB
Return Loss (On-State)	5MHz to 6GHz		15		dB
Input IP3	2.2GHz, 24dBm per tone, 1MHz spacing		75		dBm
Input IP2	Tone 1: 836.5MHz at +26dBm; Tone 2: 1718MHz at -20dBm; Rx Freq: 881.5MHz		129		dBm
	Tone 1: 1880MHz at +26dBm; Tone 2: 3840MHz at -20dBm; Rx Freq: 1960MHz		129		dBm
Spurious Output	Freq >5MHz, all ports terminated, no RF Inputs		<-105		dBm
	Freq <5MHz, all ports terminated, no RF Inputs		<-100		dBm
915MHz Second Harmonic	PIN = 33dBm		-95	-75	dBc
915MHz Third Harmonic			-90	-75	dBc
1980MHz Second Harmonic	PIN = 33dBm		-95	-75	dBc
1980MHz Third Harmonic			-90	-75	dBc
Max Operational Input Power	5MHz to 25MHz, 50Ω load			30	dBm
	25MHz to 500MHz, 50Ω load			33	dBm
	>500MHz, 50Ω load			35	dBm

Notes:

1. 50Ω Performance
2. Nominal Test Conditions Unless Otherwise Stated: VDD/EN/CTRL use typical values, T = 25°C, All RF ports terminated in 50Ω

Power-Up / Power-Down Sequence and Operational Controls

Sequence for Power UP and Power DOWN from the phone battery or supply that is connected to QPC8010Q V_{BATT} pin.

Power-up Sequence:

- 1) Turn on V_{BATT} (supply)
- 2) Then EN
- 3) Then CTRL
- 4) Then (20μs or greater)
- 5) Apply RF signal

Power-Down Sequence:

- 1) Turn off RF signal
- 2) Then CTRL
- 3) Then EN
- 4) Turn off V_{BATT} (supply)

Sequence for going in and out of a shutdown mode, keeping the VBATT or supply on, but disabling/enabling the QPC8010Q by the EN pin.

Power-Up Sequence:

- 1) Turn-on EN (enable)
- 2) Then CTRL
- 3) Then (5μs or greater)
- 4) Turn-on RF signal

Power-Down Sequence:

- 1) Turn-off RF signal
- 2) Then CTRL
- 3) Then EN (disable)

When changing switch positions between RF1 and RF2, no RF signal should be applied to any RF port while the CTRL is changing states

Switching Ports:

- 1) Turn-off RF signal
- 2) Then change CTRL state
- 3) Then (5μs or greater)
- 4) Turn-on RF signal

Typical Performance: Evaluation Board

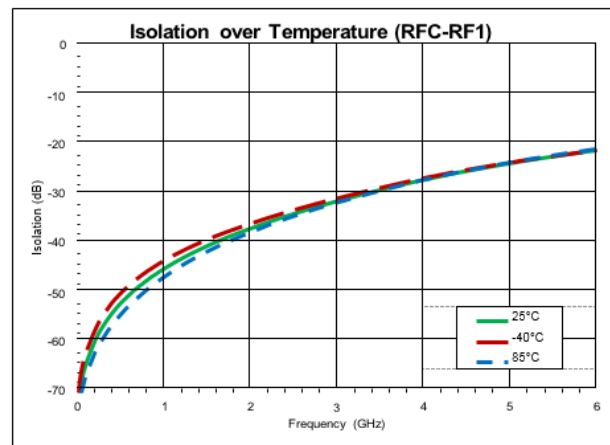
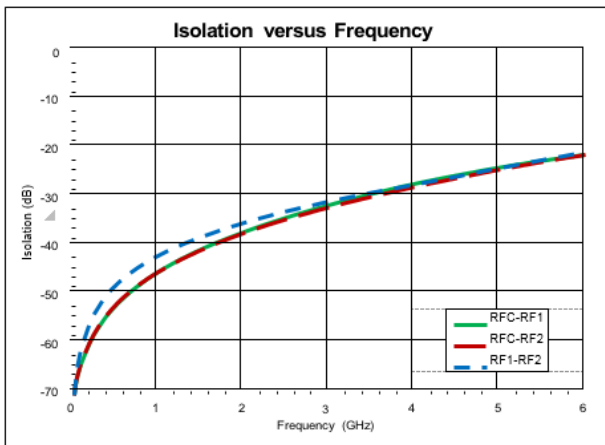
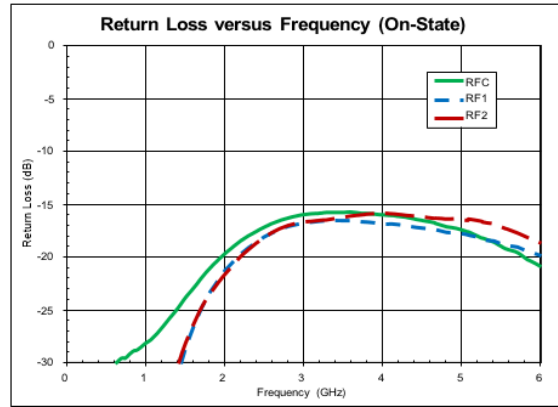
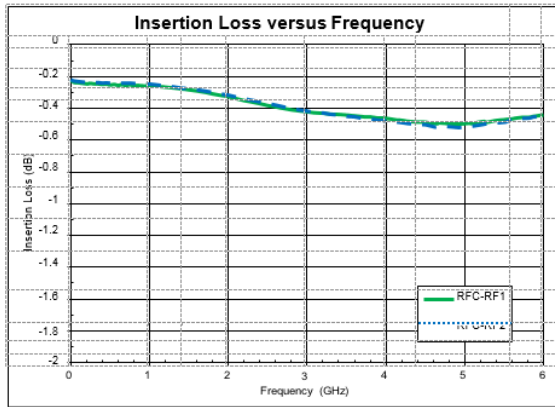

Evaluation Board Schematic

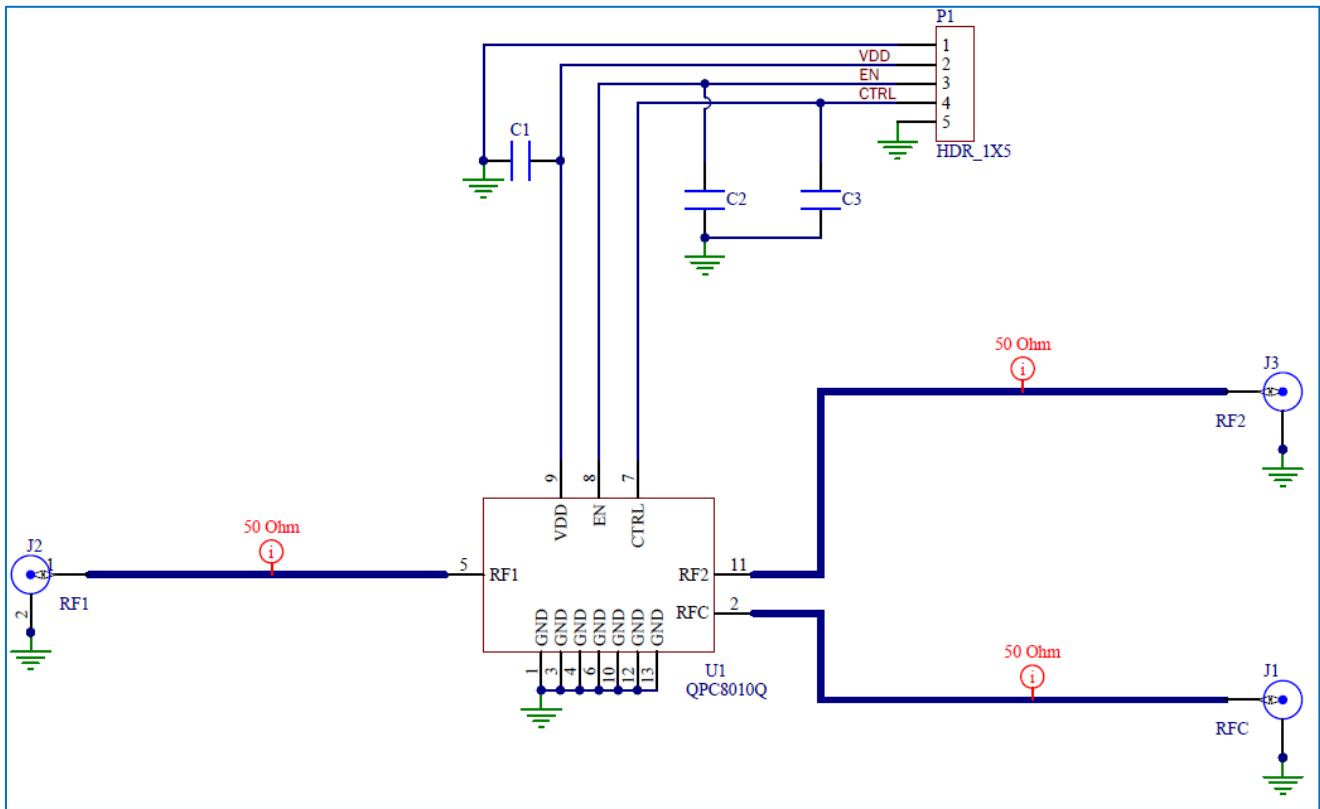

Bill of Material – QPC8010Q

Material#	Rev	Qty	Ref Des	Description	UOM
QPC8010QSB	A	1	U1	Hi Power SOI SPDT-Auto	EA
282043	A	1		PCB, QPC8010Q	EA
21709		2	C2,C3	CAP, 100pF, 5%, 50V, C0G, 0402	EA
21936		1	C1	CAP, 10000pF, 10%, 25V, X7R, 0402	EA
262452		3	J1,J2,J3	CONN, SMA, EL MINI FLT 0.068" SPE-000303	EA
42306		1	P1	CONN, HDR, ST, PLRZD, 5-PIN, 0.100"	EA

Evaluation Board – QPC8010Q-4000(A)

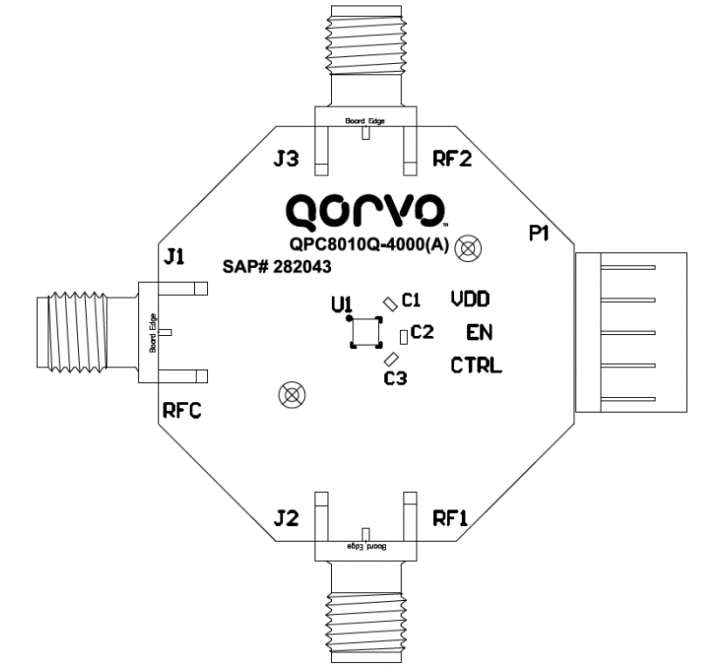

Control Logic for Valid Operational States

State	V _{DD}	CTRL	EN	RF Path
1	2.7V to 4.6V	V _{HIGH}	V _{HIGH}	ANT-RF2
2	2.7V to 4.6V	V _{LOW}	V _{HIGH}	ANT-RF1
Shutdown	2.7V to 4.6V	Don't Care	V _{LOW}	Shutdown

Pin Names and Descriptions

Pin	Name	Description
1	GND	No-connect internal, recommend GND at the EVB level.
2	RFC	Single-ended RF port. Also referred to as ANT port.
3	GND	No-connect internal, recommend GND at the EVB level.
4	GND	Ground.
5	RF1	Single-ended RF port.
6	GND	Ground.
7	CTRL	Switch logic control input.
8	EN	Shutdown logic control input.
9	VDD	Supply voltage.
10	GND	Ground.
11	RF2	Single-ended RF port.
12	GND	Ground.
13	GND	EPAD; Ground. Must be soldered to EVB GND over one or more vias.

Pin Out

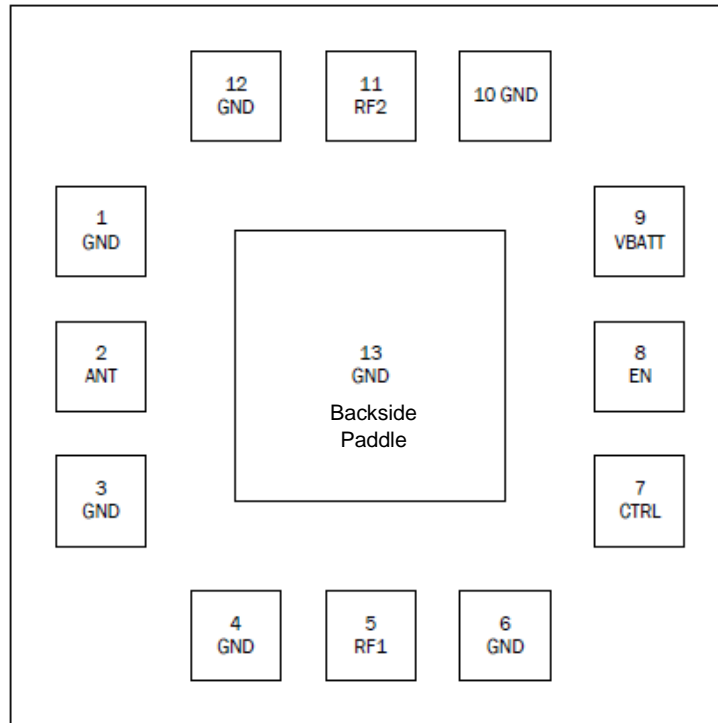

Top Side

Package Outline Drawing

Marking: 8010Q – Part Number

XXXX – Date Code

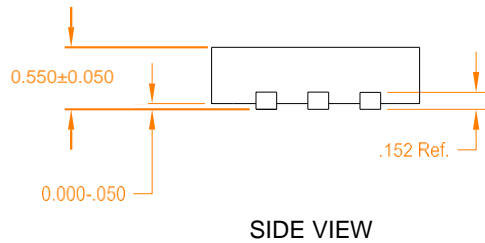
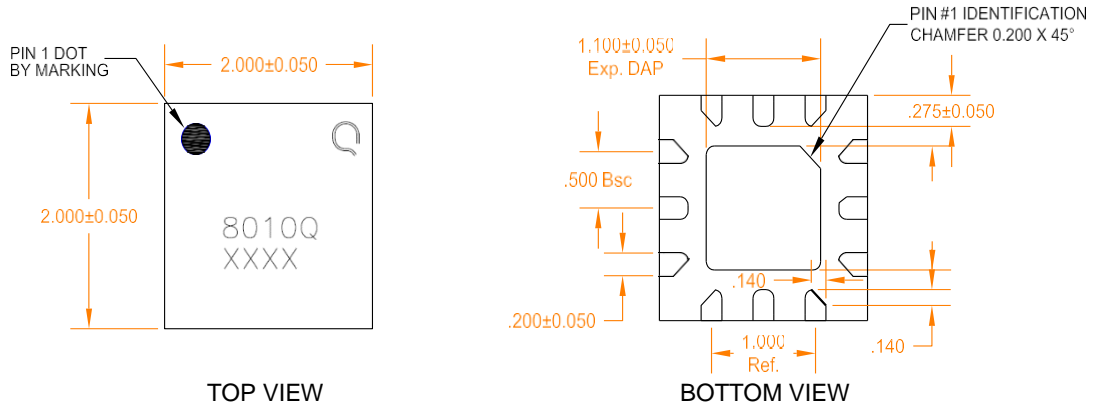

Notes:

1. All dimensions are in millimeters. Angles are in degrees.
2. Dimension and tolerance formats conform to ASME Y14.4M-1994.
3. The terminal #1 identifier and terminal numbering conform to JESD 95-1 SPP-012.

RoHS Compliance

This part is compliant with EU 2002/95/EC RoHS directive (Restrictions on the Use of Certain Hazardous Substances in Electrical and Electronic Equipment). This product also has the following attributes:

- Lead Free
- Halogen Free (Chlorine, Bromine)
- Antimony Free
- TBBP-A (C₁₅H₁₂Br₄O₂) Free
- PFOS Free
- SVHC Free
- Qorvo Green

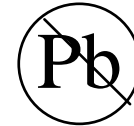

Solderability

Compatible with both lead-free (260°C max. reflow temp.) and tin/lead (245°C max. reflow temp.) soldering processes.

Solder profiles available upon request.

Contact plating: Matte Sn

Contact Information

For the latest specifications, additional product information, worldwide sales and distribution locations:

Tel: 1-844-890-8163

Web: www.qorvo.com

Email: customer.support@qorvo.com

For technical questions and application information:

Email: conn.apps@qorvo.com

Important Notice

The information contained herein is believed to be reliable; however, Qorvo makes no warranties regarding the information contained herein and assumes no responsibility or liability whatsoever for the use of the information contained herein. All information contained herein is subject to change without notice. Customers should obtain and verify the latest relevant information before placing orders for Qorvo products. The information contained herein or any use of such information does not grant, explicitly or implicitly, to any party any patent rights, licenses, or any other intellectual property rights, whether with regard to such information itself or anything described by such information. **THIS INFORMATION DOES NOT CONSTITUTE A WARRANTY WITH RESPECT TO THE PRODUCTS DESCRIBED HEREIN, AND QORVO HEREBY DISCLAIMS ANY AND ALL WARRANTIES WITH RESPECT TO SUCH PRODUCTS WHETHER EXPRESS OR IMPLIED BY LAW, COURSE OF DEALING, COURSE OF PERFORMANCE, USAGE OF TRADE OR OTHERWISE, INCLUDING THE IMPLIED WARRANTIES OF MERCHANTABILITY AND FITNESS FOR A PARTICULAR PURPOSE.**

Without limiting the generality of the foregoing, Qorvo products are not warranted or authorized for use as critical components in medical, life-saving, or life-sustaining applications, or other applications where a failure would reasonably be expected to cause severe personal injury or death.

Copyright 2016 © Qorvo, Inc. | Qorvo is a registered trademark of Qorvo, Inc.

Looking for pricing, stock, or lifecycle information?

Click below to explore more details on WIN SOURCE:

 [View QPC8010QTR7 on WIN SOURCE](#)

 [Qorvo US Inc. Information](#)

Optimize Your Supply Chain with WIN SOURCE Solutions

-  Global Sourcing Solution
-  Obsolete Management
-  Cost Control Management
-  Shortage Management
-  Alternative Solution
-  Excess Inventory Management