

BGSA144ML10

Ultra High RF Voltage Antenna Tuning SP4T

Features

- Low R_{ON} resistance of 1.74Ω at each RF port in ON state.
- Ultra low C_{OFF} capacitance of 89 fF in OFF state
- Individually controlled reflective open or short to ground OFF ports to eliminate unwanted antenna resonances
- High RF operating voltage handling 80 V in OFF state
- MIPI RFFE 2.1 compliant control interface
- External USID_Sel pin enabling 4 default USID addresses
- Small form factor 1.1 mm x 1.5 mm (MSL1, 260°C per JEDEC J-STD-020)
- RoHS and WEEE compliant package

- ✓ RoHS
- HAL Halogen-Free
- Pb Lead-Free
- Green

Potential applications

- Impedance, Antenna and Inductance Tuning
- Tunable Filters

Product validation

Qualified for industrial applications according to the relevant tests of JEDEC47/20/22.

Description

The BGSA144ML10 is a Single-Pole Four Throws (SP4T) Antenna Tuning switch optimized for RF applications up to 7.125 GHz. The BGSA144ML10 is made of 4 low On resistance / low Off capacitance series switches and 4 shunt to ground switches enabling on-demand open-reflective or short-reflective OFF ports behaviour. This last feature is of great value to reduce antenna engineer development time in case of unwanted antenna resonance or to improve antenna efficiency with less component tuning effort.

Block diagram

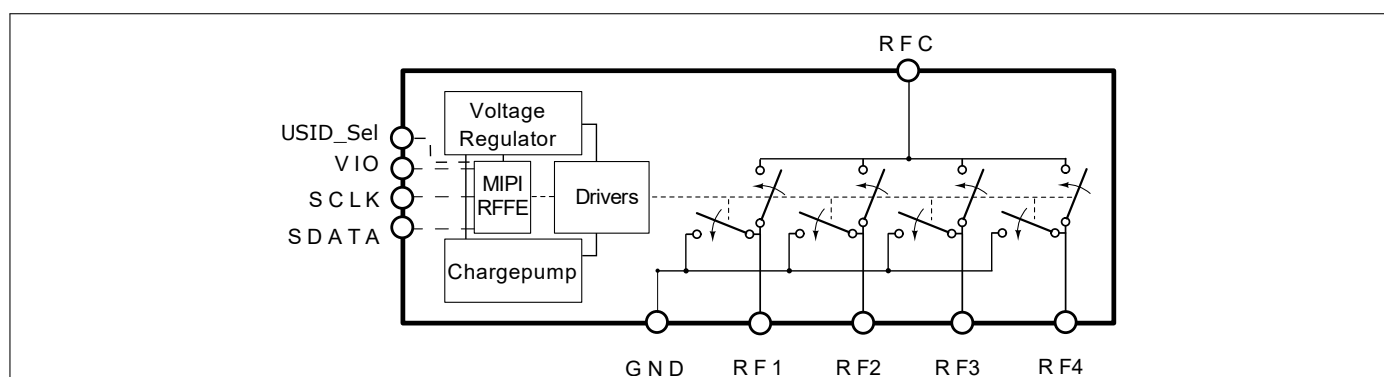

Type	Marking	Package	Ordering Information
BGSA144ML10	A4	TSLP-10-3	BGSA 144ML10 E6327

BGSA144ML10

Ultra High RF Voltage Antenna Tuning SP4T

Table of Contents

Table of Contents

1	Maximum Ratings	2
2	DC Characteristics	4
3	RF Small Signal Characteristics	5
4	RF large signal parameter	8
5	MIPI RFFE Specification	10
6	Application Information	18
7	Package Information	20

BGSA144ML10

Ultra High RF Voltage Antenna Tuning SP4T

Maximum Ratings

1 Maximum Ratings

Table 1: Maximum Ratings Table at $T_A = 25^\circ\text{C}$, unless otherwise specified

Parameter	Symbol	Values			Unit	Note / Test Condition
		Min.	Typ.	Max.		
Frequency Range	f	0.4	–	7.125	GHz	¹⁾
RFFE Supply voltage ²⁾	V_{IO}	-0.3	–	2.2	V	Only for infrequent and short duration time periods
Storage temperature range	T_{STG}	-55	–	150	°C	–
RF peak voltage	V_{RF_max}	–	–	85	V	Short term peaks (1 μ s in 0.1% duty cycle), exceeding typical linearity, Ron and Coff parameters, in Isolation mode, test condition schematic in Fig. 1
ESD robustness, CDM ³⁾	V_{ESDCDM}	-1	–	+1	kV	
ESD robustness, HBM ⁴⁾	V_{ESDHBM}	-2	–	+2	kV	
Junction temperature	T_j	–	–	125	°C	–
Thermal resistance junction - soldering point	R_{thJS}	–	–	90	K/W	–
Maximum DC-voltage on RF-Ports and RF-Ground	V_{RFDC}	0	–	0	V	No DC voltages allowed on RF-Ports
RFFE Control Voltage Levels	V_{SCLK} , V_{SDATA} , V_{USID_SEL}	-0.7	–	$V_{IO}+0.7$ (max. 2.2)	V	–

¹⁾ Switch has a low-pass response. For higher frequencies, losses have to be considered for their impact on thermal heating. The DC voltage at RF ports V_{RFDC} has to be 0V.

²⁾ Note: Consider any ripple voltages on top of V_{IO} . A high RF ripple at the V_{IO} can exceed the maximum ratings by $V_{IO} = V_{DC} + V_{Ripple}$.

³⁾ Field-Induced Charged-Device Model ANSI/ESDA/JEDEC JS-002. Simulates charging/discharging events that occur in production equipment and processes. Potential for CDM ESD events occurs whenever there is metal-to-metal contact in manufacturing.

⁴⁾ Human Body Model ANSI/ESDA/JEDEC JS-001 (R=1.5 k Ω , C=100 pF).

Warning: Stresses above the max. values listed here may cause permanent damage to the device. Maximum ratings are absolute ratings; exceeding only one of these values may cause irreversible damage to the integrated circuit. Exposure to conditions at or below absolute maximum rating but above the specified maximum operation conditions may affect device reliability and life time. Functionality of the device might not be given under these conditions.

BGSA144ML10

Ultra High RF Voltage Antenna Tuning SP4T

Maximum Ratings

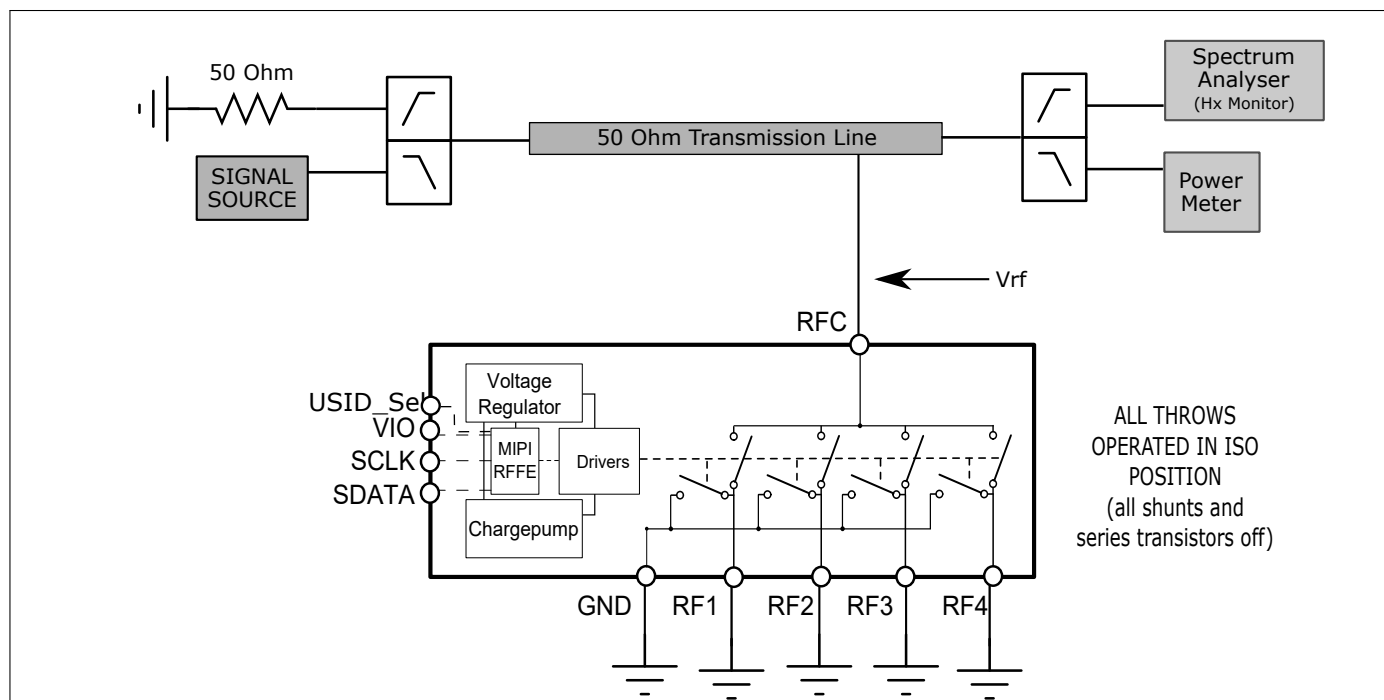

Figure 1: RF operating voltage measurement configuration - OFF mode

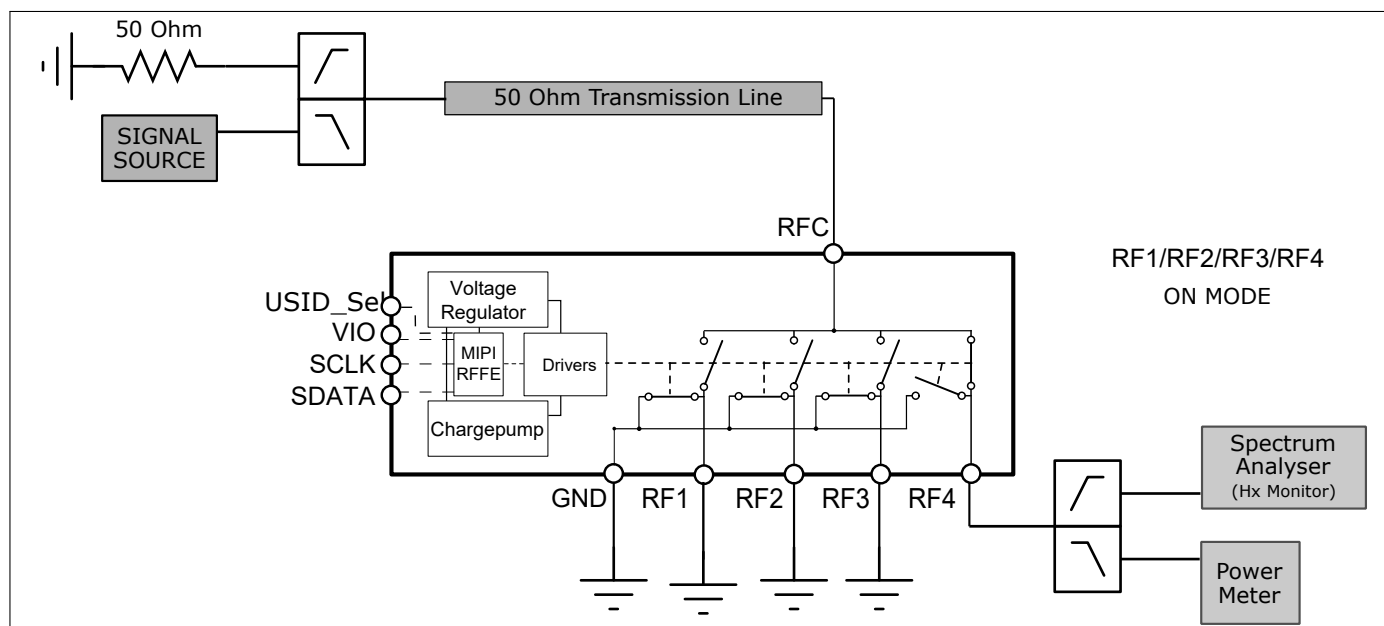

Figure 2: RF operating and Harmonics generation measurement configuration - RFX ON mode (RF4 as example)

BGSA144ML10

Ultra High RF Voltage Antenna Tuning SP4T

DC Characteristics

2 DC Characteristics

Table 2: DC Characteristics at $T_A = -40\text{ °C}$ to 85 °C

Parameter	Symbol	Values			Unit	Note / Test Condition
		Min.	Typ.	Max.		
RFFE supply voltage	V_{IO}	1.65	1.8	1.95	V	–
RFFE input high voltage ¹	V_{IH}	$0.7 \cdot V_{IO}$	–	V_{IO}	V	–
RFFE input low voltage ¹	V_{IL}	0	–	$0.3 \cdot V_{IO}$	V	–
RFFE output high voltage ¹	V_{OH}	$0.8 \cdot V_{IO}$	–	V_{IO}	V	–
RFFE output low voltage ¹	V_{OL}	0	–	$0.2 \cdot V_{IO}$	V	–
RFFE control input capacitance	C_{Ctrl}	–	–	2	pF	–
RFFE supply current ²	I_{VIO}	–	22	40	μA	ACTIVE mode
		–	2	8	μA	SECONDARY_ACTIVE mode (LOW POWER) with analog circuitry powered OFF
		–	0.5^3	1^3	μA	

¹SCLK and SDATA

²No traffic on MIPI bus

³Supply current reduced after first MIPI RFFE command

BGSA144ML10

Ultra High RF Voltage Antenna Tuning SP4T

RF Small Signal Characteristics

3 RF Small Signal Characteristics

Table 3: Parametric specifications

Parameter	Symbol	Values			Unit	STATE / Notes
		Min.	Typ.	Max.		
Series switch ON DC resistance	R_{ON_Series}	–	1.74	1.95	Ω	$V_{IO} = 1.65 - 1.95 V,$ $T_A = 25^\circ C,$ $Z_0 = 50 \Omega$
Shunt to GND switch ON DC resistance	R_{ON_Shunt}	–	6	7	Ω	
OFF capacitance ⁽¹⁾ , 1GHz RF1 or RF2 to RFC RF3 or RF4 to RFC	C_{OFF}	–	89 93	–	fF fF	

¹⁾ OFF capacitance calculated from Y21 parameters.

BGSA144ML10

Ultra High RF Voltage Antenna Tuning SP4T

RF Small Signal Characteristics

Table 4: RF electrical parameters, OFF port shunts switches open

Parameter	Symbol	Values			Unit	STATE / Notes
		Min.	Typ.	Max.		
Insertion Loss: RFC to RFx ^(1,2,3)						
600 - 960 MHz	<i>IL_{SP4T}</i>		0.25	0.5	dB	<i>V_{IO}</i> = 1.65 – 1.95 V, <i>Z₀</i> = 50 Ω at all RF-ports, <i>T_A</i> = –40 °C... + 85 °C
1400 - 1700 MHz			0.3	0.6	dB	
1710 - 2169 MHz			0.4	0.7	dB	
2170 - 2690 MHz			0.5	0.8	dB	
3300 - 4200 MHz			0.85	1.4	dB	
4400 - 5000 MHz			1.2	1.8	dB	
5150 - 5925 MHz			1.4	2.2	dB	
5926 - 7125 MHz			1.7	2.9	dB	
Return Loss: RFC to RFx ^(1,2,3)						
600 - 960 MHz	<i>RL_{SP4T}</i>	20	28		dB	<i>V_{IO}</i> = 1.65 – 1.95 V, <i>Z₀</i> = 50 Ω at all RF-ports, <i>T_A</i> = –40 °C... + 85 °C
1400 - 1700 MHz		15	21		dB	
1710 - 2169 MHz		14	19		dB	
2170 - 2690 MHz		12	17		dB	
3300 - 4200 MHz		7	12		dB	
4400 - 5000 MHz		6	10		dB	
5150 - 5925 MHz		5	9		dB	
5926 - 7125 MHz		4	8		dB	
RFx to RFy OFF state (state 0) Isolation: RFx, RFy series & RFx, RFy shunt OFF ^(1,2,3)						
600 - 960 MHz	<i>ISO_{OFF}</i>	33	50		dB	<i>V_{IO}</i> = 1.65 – 1.95 V, <i>Z₀</i> = 50 Ω at all RF-ports, <i>T_A</i> = –40 °C... + 85 °C
1400 - 1700 MHz		28	41		dB	
1710 - 2169 MHz		25	38		dB	
2170 - 2690 MHz		23	34		dB	
3300 - 4200 MHz		19	29		dB	
4400 - 5000 MHz		18	26		dB	
5150 - 5925 MHz		17	25		dB	
5926 - 7125 MHz		12	24		dB	

¹⁾ Valid for all RF power levels, no compression behavior, x, y = 1,2,3,4

²⁾ On application board without any matching components

³⁾ Shunts in OFF Mode

BGSA144ML10

Ultra High RF Voltage Antenna Tuning SP4T

RF Small Signal Characteristics

Table 5: RF electrical parameters, OFF port shunts switches closed

Parameter	Symbol	Values			Unit	STATE / Notes
		Min.	Typ.	Max.		
Insertion Loss: RFC to RFx ^(1,2,3)						
600 - 960 MHz	<i>IL_{SP4T}</i>		0.25	0.5	dB	<i>V_{IO}</i> = 1.65 – 1.95 V, <i>Z₀</i> = 50 Ω at all RF-ports, <i>T_A</i> = –40 °C... + 85 °C
1400 - 1700 MHz			0.3	0.6	dB	
1710 - 2169 MHz			0.35	0.7	dB	
2170 - 2690 MHz			0.4	0.9	dB	
3300 - 4200 MHz			0.8	1.5	dB	
4400 - 5000 MHz			1.2	2	dB	
5150 - 5925 MHz			1.6	2.8	dB	
5926 - 7125 MHz			2.1	3.5	dB	
Return Loss: RFC to RFx ^(1,2,3)						
600 - 960 MHz	<i>RL_{SP4T}</i>	20	28		dB	<i>V_{IO}</i> = 1.65 – 1.95 V, <i>Z₀</i> = 50 Ω at all RF-ports, <i>T_A</i> = –40 °C... + 85 °C
1400 - 1700 MHz		15	21		dB	
1710 - 2169 MHz		14	18		dB	
2170 - 2690 MHz		12	16		dB	
3300 - 4200 MHz		7	11		dB	
4400 - 5000 MHz		5	9		dB	
5150 - 5925 MHz		4	8		dB	
5926 - 7125 MHz		4	7		dB	
RFx to RFy OFF state (state 1) Isolation: RFx, RFy series & RFx shunt OFF, RFy shunt ON ^(1,2,3)						
600 - 960 MHz	<i>ISO_{OFF}</i>	18	30		dB	<i>V_{IO}</i> = 1.65 – 1.95 V, <i>Z₀</i> = 50 Ω at all RF-ports, <i>T_A</i> = –40 °C... + 85 °C
1400 - 1700 MHz		13	24		dB	
1710 - 2169 MHz		11	23		dB	
2170 - 2690 MHz		10	21		dB	
3300 - 4200 MHz		7	19		dB	
4400 - 5000 MHz		6	17		dB	
5150 - 5925 MHz		5	16		dB	
5926 - 7125 MHz		4	15		dB	

¹⁾ Valid for all RF power levels, no compression behavior, x, y = 1,2,3,4

²⁾ On application board without any matching components

³⁾ Shunts in ON Mode

RF large signal parameter

4 RF large signal parameter

Table 6: RF large signal specifications at $T_A = 25\text{ °C}$

Parameter	Symbol	Values			Unit	Note / Test Condition
		Min.	Typ.	Max.		
RF Operating Voltage	V_{RF_opr}	–	80	–	V	In Isolation mode, 900 MHz test condition schematic in Fig. 1
Harmonic Generation up to 15 GHz, while RFx series ON, RFx shunt OFF, RFy series OFF, RFy shunt ON						
All RF Ports - Second Order Harmonics	P_{H2}	–	-87	-80	dBm	26 dBm, 50 Ω , $f_0 = 663\text{ MHz}$
All RF Ports - Third Order Harmonics	P_{H3}	–	-102	-95	dBm	26 dBm, 50 Ω , $f_0 = 663\text{ MHz}$
All RF Ports - Second Order Harmonics	P_{H2}	–	-69	-62	dBm	35 dBm, 50 Ω , $f_0 = 920\text{ MHz}$
All RF Ports - Third Order Harmonics	P_{H3}	–	-75	-64	dBm	35 dBm, 50 Ω , $f_0 = 920\text{ MHz}$
All RF Ports - Second Order Harmonics	P_{H2}	–	-63	-59	dBm	33 dBm, 50 Ω , $f_0 = 1910\text{ MHz}$
All RF Ports - Third Order Harmonics	P_{H3}	–	-75	-68	dBm	33 dBm, 50 Ω , $f_0 = 1910\text{ MHz}$
All RF Ports - Second Order Harmonics	P_{H2}	–	-68	-63	dBm	29 dBm, 50 Ω , $f_0 = 2690\text{ MHz}$
All RF Ports - Third Order Harmonics	P_{H3}	–	-80	-62	dBm	29 dBm, 50 Ω , $f_0 = 2690\text{ MHz}$
All RF Ports - Second Order Harmonics	P_{H2}	–	-64	-55	dBm	29 dBm, 50 Ω , $f_0 = 3600\text{ MHz}$
All RF Ports - Third Order Harmonics	P_{H3}	–	-80	-68	dBm	29 dBm, 50 Ω , $f_0 = 3600\text{ MHz}$
All RF Ports - Second Order Harmonics	P_{H2}	–	-66	-60	dBm	29 dBm, 50 Ω , $f_0 = 4400\text{ MHz}$
All RF Ports - Third Order Harmonics	P_{H3}	–	-79	-71	dBm	29 dBm, 50 Ω , $f_0 = 4400\text{ MHz}$
All RF Ports - Second Order Harmonics	P_{H2}	–	-65	-59	dBm	29 dBm, 50 Ω , $f_0 = 5000\text{ MHz}$
All RF Ports - Third Order Harmonics	P_{H3}	–	-80	-70	dBm	29 dBm, 50 Ω , $f_0 = 5000\text{ MHz}$
Intermodulation Distortion IMD2						
IIP2, low	$IIP2, l$	115	125	–	dBm	IIP2 conditions Tab. 7
IIP2, high	$IIP2, h$	115	125	–	dBm	
Intermodulation Distortion IMD3						
IIP3	$IIP3$	70	81	–	dBm	IIP3 conditions Tab. 8

BGSA144ML10

Ultra High RF Voltage Antenna Tuning SP4T

RF large signal parameter

Table 7: IIP2 conditions table

Band	In-Band Frequency [MHz]	Blocker Frequency 1 [MHz]	Blocker Power 1 [dBm]	Blocker Frequency 2 [MHz]	Blocker Power 2 [dBm]
Band 1 Low	2140	1950	23	190	0
Band 1 High	2140	1950	23	4090	0
Band 5 Low	881.5	836.5	23	45	0
Band 5 High	881.5	836.5	23	1718	0
Band 7 Low	2655	120	23	2535	0
Band 7 High	2655	5910	23	2535	0

Table 8: IIP3 conditions table

Band	In-Band Frequency [MHz]	Blocker Frequency 1 [MHz]	Blocker Power 1 [dBm]	Blocker Frequency 2 [MHz]	Blocker Power 2 [dBm]
Band 1	2140	1950	23	1760	0
Band 5	881.5	836.5	23	791.5	0
Band 7	2655	2415	23	2535	0

BGSA144ML10

Ultra High RF Voltage Antenna Tuning SP4T

MIPI RFFE Specification

5 MIPI RFFE Specification

The MIPI RFFE interface is implemented according to the following specifications and documents:

- MIPI Alliance Specification for RF Front-End Control Interface version 2.1 - 18 December 2017
- MIPI Alliance Errata 01 for MIPI RFFE Specification Version v2.1 - 24 February 2019
- Qualcomm RFFE Vendor specification 80-N7876-1 Rev. Y (December 3, 2018)

Table 9: MIPI Features

Feature	Supported	Comment
MIPI RFFE 2.1 standard	Yes	Backward compatible to MIPI 2.0 standard
Register 0 write command sequence	Yes	
Register read and write command sequence	Yes	
Extended register read and write command sequence	Yes	
Masked write command sequence	Yes	Indicated as MW in below register mapping tables
Support for standard frequency range operations for SCLK	Yes	Up to 26 MHz
Support for extended frequency range operations for SCLK	Yes	Up to 52 MHz
Longer Reach RFFE Bus Length Feature	Yes	
Programmable driver strength	Yes	Up to 80 pF
Programmable Group SID	Yes	
Programmable USID	Yes	
Trigger functionality	Yes	
Extended Triggers and Trigger Masks	Yes	
Broadcast / GSID write to PM TRIG register	Yes	
Reset	Yes	Via VIO, PM TRIG or software register
Status / error sum register	Yes	
Extended product ID register	Yes	
Revision ID register	Yes	
Group SID register	Yes	
USID select pin	Yes	USID selection See Tab. 10

BGSA144ML10

Ultra High RF Voltage Antenna Tuning SP4T

MIPI RFFE Specification

Table 10: Default MIPI USID Selection

Address	Symbol	External Condition at USID Port
USID=0110	Addr6	Ground
USID=0111	Addr7	to VIO
USID=1000	Addr8	220 kΩ to VIO ¹⁾
USID=1001	Addr9	Floating ¹⁾

¹⁾ Total capacitance on the USID_SEL pin must be <5 pF.

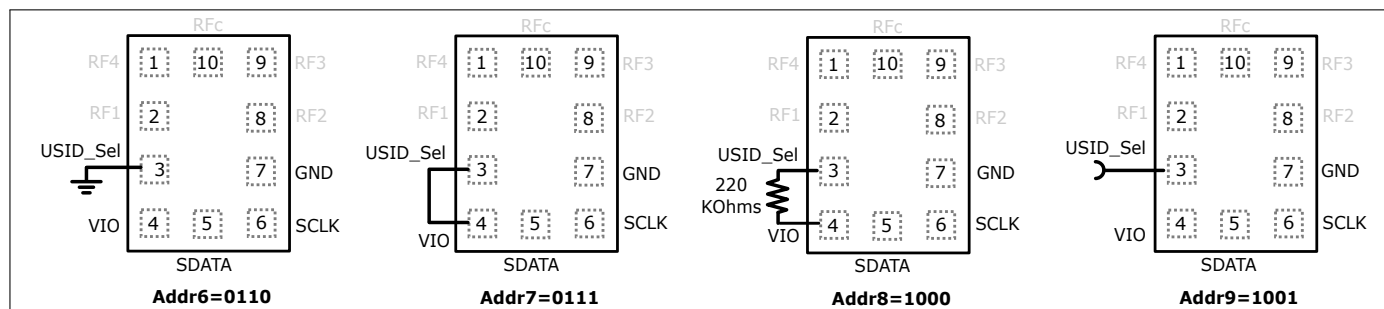

Figure 3: BGSA144ML10 USID_Sel Pin Configuration

Table 11: Startup Behavior

Feature	State	Comment
Power status	Low power	Lower power mode after start-up
Trigger function	Enabled	Enabled after start-up. Programmable via behavior control register

BGSA144ML10

Ultra High RF Voltage Antenna Tuning SP4T

MIPI RFFE Specification

Table 12: Switching Time Behavior at $V_{IO} = 1.65 - 1.95 V$, $T_A = -40^\circ C \dots + 85^\circ C$, $P_{IN} = 0 dBm$

Parameter	Symbol	Values			Unit	STATE / Notes
		Min.	Typ.	Max.		
Power Up Settling Time	t_{PUP}	-	-	15	μs	Time from 50% last SCLK rising edge of the register write command after Analog Circuitry Powered On command to 10% / 90% of RF amplitude on the RF Path, see Fig. 4
Switching Time RF Path A to RF Path B	t_{ST}	-	-	18	μs	Time from 50% last SCLK rising edge of the register write command to 90% of RF amplitude on the RF Path B, see Fig. 4

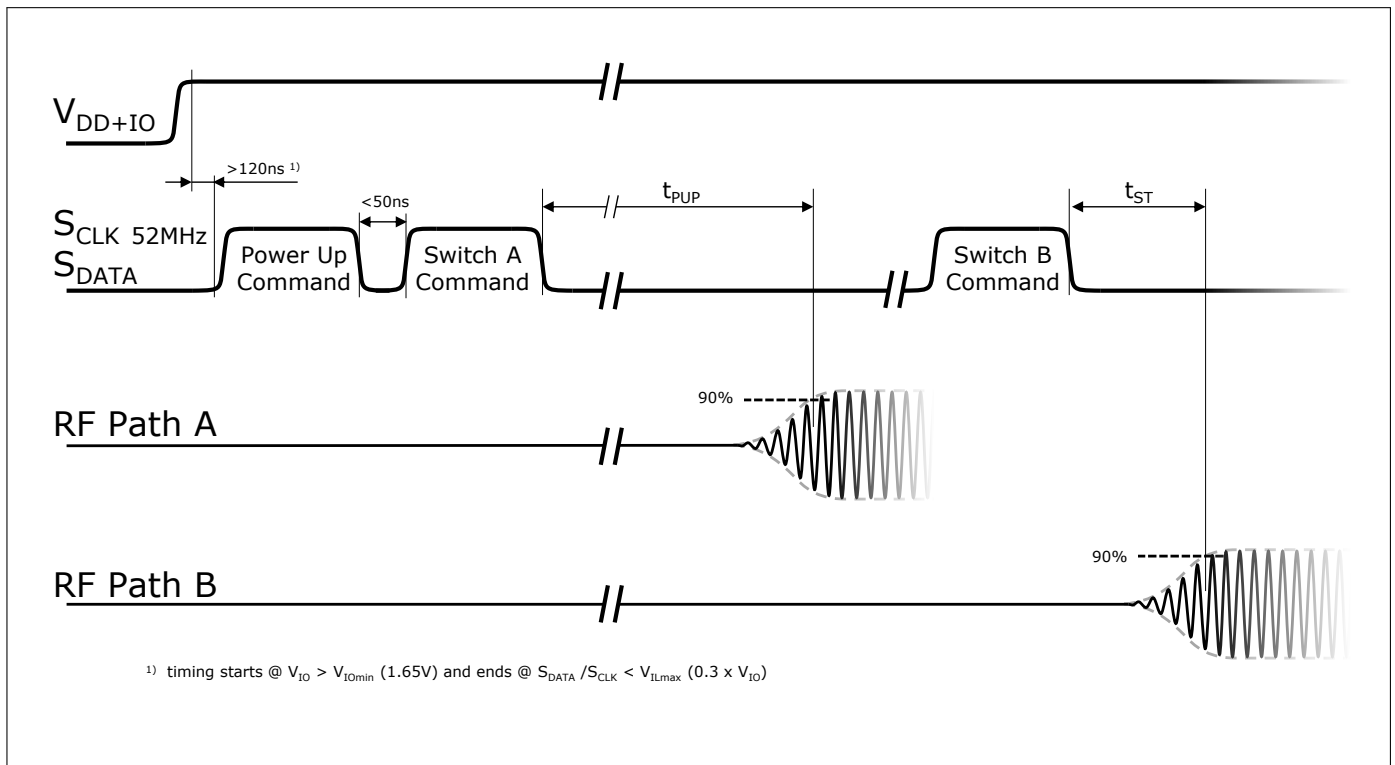

Figure 4: BGSA144ML10 Switching Time Behavior

BGSA144ML10

Ultra High RF Voltage Antenna Tuning SP4T



MIPI RFFE Specification

Table 13: Register Mapping, Table I

Register Address	Register Name	Data Bits	Function	Description	Default	Broadcast_ID Support	Trigger Support	R/W	
0x00	REGISTER_0	7:0	MODE_CTRL	RF Switch Control	00000000	No	Yes Trigger 0-10	R/W MW	
0x01	REGISTER_1	7:0	MODE_CTRL	RF Switch Control	00000000	No	Yes Trigger 0-10	R/W MW	
0x1C	PM_TRIG	7	PWR_MODE(1) Operation Mode	0: Normal operation (ACTIVE)	1	Yes	No	R/W MW	
				1: Low Power Mode (LOW POWER)					
		6	PWR_MODE(0) State Bit Vector	0: No action (ACTIVE)	0				
				1: Powered Reset (STARTUP to ACTIVE to LOW POWER)					
		5	TRIGGER_MASK_2	0: Data masked (held in shadow REG)	0				No
				1: Data not masked (ready for transfer to active REG)					
		4	TRIGGER_MASK_1	0: Data masked (held in shadow REG)	0				
				1: Data not masked (ready for transfer to active REG)					
		3	TRIGGER_MASK_0	0: Data masked (held in shadow REG)	0				
1: Data not masked (ready for transfer to active REG)									
2	TRIGGER_2	0: No action (data held in shadow REG)	0	Yes					
		1: Data transferred to active REG							
1	TRIGGER_1	0: No action (data held in shadow REG)	0						
		1: Data transferred to active REG							
0	TRIGGER_0	0: No action (data held in shadow REG)	0						
		1: Data transferred to active REG							
0x1D	PRODUCT_ID	7:0	PRODUCT_ID	This is a read-only register. However, during the programming of the USID a write command sequence is performed on this register, even though the write does not change its value.	00110111	No	No	R	
0x1E	MAN_ID	7:0	MANUFACTURER_ID [7:0]	This is a read-only register. However, during the programming of the USID, a write command sequence is performed on this register, even though the write does not change its value.	00011010	No	No	R	
0x1F	MAN_USID	7:4	MANUFACTURER_ID [11:8]	These bits are read-only. However, during the programming of the USID, a write command sequence is performed on this register even though the write does not change its value.	0001				
		3:0	USID[3:0]	USID_Sel pin	See Tab. 10	No	No	R/W	

BGSA144ML10

Ultra High RF Voltage Antenna Tuning SP4T



MIPI RFFE Specification

Table 14: Register Mapping, Table II

Register Address	Register Name	Data Bits	Function	Description	Default	Broadcast_ID Support	Trigger Support	R/W
0x20	EXT_PRODUCT_ID	7:0	EXT_PRODUCT_ID	Extension to PRODUCT_ID in register 0x1D. This is a read-only register. However, during the programming of the USID a write command sequence is performed on this register, even though the write does not change its value.	00000000	No	No	R
0x21	REV_ID	7:4	MAIN_REVISION	Chip main revision	0000	No	No	R
		3:0	SUB_REVISION	Chip sub revision	0000			
0x22	GSID	7:4	GSID0[3:0]	Primary Group Slave ID.	0000	No	No	R/W
		3:0	GSID1[3:0]	Secondary Group Slave ID.	0000			
0x23	UDR_RST	7	UDR_RST	Reset all configurable non-RFFE Reserved registers to default values. 0: Normal operation 1: Software reset	0	Yes	No	R/W
		6:0	RESERVED	Reserved for future use	00000000			
0x24	ERR_SUM	7	RESERVED	Reserved for future use	0	No	No	R
		6	COMMAND_FRAME_PARITY_ERR	Command Sequence received with parity error – discard command.	0			
		5	COMMAND_LENGTH_ERR	Command length error.	0			
		4	ADDRESS_FRAME_PARITY_ERR	Address frame with parity error.	0			
		3	DATA_FRAME_PARITY_ERR	Data frame with parity error.	0			
		2	READ_UNUSED_REG	Read command to an invalid address.	0			
		1	WRITE_UNUSED_REG	Write command to an invalid address.	0			
		0	BID_GID_ERR	Read command with a BROADCAST_ID or GROUP_ID.	0			
0x2B	BUS_LD	7:3	RESERVED	Reserved for future use	0x0	No	No	R/W
		2:0	BUS_LD[2:0]	Program the drive strength of the SDATA driver in readback modes. 0x0: 10 pF 0x1: 20 pF 0x2: 30 pF 0x3: 40 pF 0x4: 50 pF 0x5: 60 pF 0x6: 80 pF 0x7: 80 pF 0x8-0xF: reserved	0x4			

BGSA144ML10

Ultra High RF Voltage Antenna Tuning SP4T



MIPI RFFE Specification

Table 15: Register Mapping, Table III

Register Address	Register Name	Data Bits	Function	Description	Default	Broadcast_ID Support	Trigger Support	R/W	
0x2D	EXT_TRIG_MASK	7	TRIGGER_MASK_10	0: Data writes to registers tied to EXT_TRIGGER_10 are masked. Data is held in shadow registers until the EXT_TRIGGER_10 bit is set to 1.	1	No	No	R/W	
				1: Data writes to registers tied to EXT_TRIGGER_10 are not masked. Data writes go directly to the active registers.					
		6	TRIGGER_MASK_9	0: Data writes to registers tied to EXT_TRIGGER_9 are masked. Data is held in shadow registers until the EXT_TRIGGER_9 bit is set to 1.	1				MW
				1: Data writes to registers tied to EXT_TRIGGER_9 are not masked. Data writes go directly to the active registers.					
		5	TRIGGER_MASK_8	0: Data writes to registers tied to EXT_TRIGGER_8 are masked. Data is held in shadow registers until the EXT_TRIGGER_8 bit is set to 1.	1				
				1: Data writes to registers tied to EXT_TRIGGER_8 are not masked. Data writes go directly to the active registers.					
		4	TRIGGER_MASK_7	0: Data writes to registers tied to EXT_TRIGGER_7 are masked. Data is held in shadow registers until the EXT_TRIGGER_7 bit is set to 1.	1				
				1: Data writes to registers tied to EXT_TRIGGER_7 are not masked. Data writes go directly to the active registers.					
		3	TRIGGER_MASK_6	0: Data writes to registers tied to EXT_TRIGGER_6 are masked. Data is held in shadow registers until the EXT_TRIGGER_6 bit is set to 1.	1				
				1: Data writes to registers tied to EXT_TRIGGER_6 are not masked. Data writes go directly to the active registers.					
		2	TRIGGER_MASK_5	0: Data writes to registers tied to EXT_TRIGGER_5 are masked. Data is held in shadow registers until the EXT_TRIGGER_5 bit is set to 1.	1				
				1: Data writes to registers tied to EXT_TRIGGER_5 are not masked. Data writes go directly to the active registers.					
		1	TRIGGER_MASK_4	0: Data writes to registers tied to EXT_TRIGGER_4 are masked. Data is held in shadow registers until the EXT_TRIGGER_4 bit is set to 1.	1				
				1: Data writes to registers tied to EXT_TRIGGER_4 are not masked. Data writes go directly to the active registers.					
0	TRIGGER_MASK_3	0: Data writes to registers tied to EXT_TRIGGER_3 are masked. Data is held in shadow registers until the EXT_TRIGGER_3 bit is set to 1.	1						
		1: Data writes to registers tied to EXT_TRIGGER_3 are not masked. Data writes go directly to the active registers.							

BGSA144ML10

Ultra High RF Voltage Antenna Tuning SP4T



MIPI RFFE Specification

Table 16: Register Mapping, Table IV

Register Address	Register Name	Data Bits	Function	Description	Default	Broadcast_ID Support	Trigger Support	R/W
0x2E	EXT_TRIG	7	TRIGGER_10	0: No action. Data is held in shadow registers.	0	Yes	No	R/W
				1: Data is transferred from shadow registers to active registers for registers tied to EXT_TRIGGER_10				
		6	TRIGGER_9	0: No action. Data is held in shadow registers.	0			
				1: Data is transferred from shadow registers to active registers for registers tied to EXT_TRIGGER_9				
		5	TRIGGER_8	0: No action. Data is held in shadow registers.	0			
				1: Data is transferred from shadow registers to active registers for registers tied to EXT_TRIGGER_8				
		4	TRIGGER_7	0: No action. Data is held in shadow registers.	0			
				1: Data is transferred from shadow registers to active registers for registers tied to EXT_TRIGGER_7				
		3	TRIGGER_6	0: No action. Data is held in shadow registers.	0			
				1: Data is transferred from shadow registers to active registers for registers tied to EXT_TRIGGER_6				
		2	TRIGGER_5	0: No action. Data is held in shadow registers.	0			
				1: Data is transferred from shadow registers to active registers for registers tied to EXT_TRIGGER_5				
		1	TRIGGER_4	0: No action. Data is held in shadow registers.	0			
				1: Data is transferred from shadow registers to active registers for registers tied to EXT_TRIGGER_4				
		0	TRIGGER_3	0: No action. Data is held in shadow registers.	0			
				1: Data is transferred from shadow registers to active registers for registers tied to EXT_TRIGGER_3				

BGSA144ML10

Ultra High RF Voltage Antenna Tuning SP4T

MIPI RFFE Specification

Warning: Register_0 and Register_1 RF switch control bits are identical. Writing both Registers Register_0 and Register_1 simultaneously will lead to undefined behavior. The unused register (Register_0 or Register_1) must remain 0x00.

Table 17: Modes of Operation (Truth Table, Register_0)

State	Mode	D7	D6	D5	D4	D3	D2	D1	D0
0	ALL Series OFF (All Shunts OFF)	0	0	0	0	0	0	0	0
1	ALL Series OFF (All Shunts ON)	1	1	1	1	0	0	0	0
2	RF1 Series	0	0	0	0	0	0	0	1
3	RF2 Series	0	0	0	0	0	0	1	0
4	RF3 Series	0	0	0	0	0	1	0	0
5	RF4 Series	0	0	0	0	1	0	0	0
6	RF1 Shunt	0	0	0	1	0	0	0	0
7	RF2 Shunt	0	0	1	0	0	0	0	0
8	RF3 Shunt	0	1	0	0	0	0	0	0
9	RF4 Shunt	1	0	0	0	0	0	0	0

Mapping of Switch Rows to Bit: ON = 1 OFF = 0

Table 18: Modes of Operation (Truth Table, Register_1)

State	Mode	D7	D6	D5	D4	D3	D2	D1	D0
0	ALL Series OFF (All Shunts OFF)	0	0	0	0	0	0	0	0
1	ALL Series OFF (All Shunts ON)	1	1	1	1	0	0	0	0
2	RF1 Series	0	0	0	0	0	0	0	1
3	RF2 Series	0	0	0	0	0	0	1	0
4	RF3 Series	0	0	0	0	0	1	0	0
5	RF4 Series	0	0	0	0	1	0	0	0
6	RF1 Shunt	0	0	0	1	0	0	0	0
7	RF2 Shunt	0	0	1	0	0	0	0	0
8	RF3 Shunt	0	1	0	0	0	0	0	0
9	RF4 Shunt	1	0	0	0	0	0	0	0

Mapping of Switch Rows to Bit: ON = 1 OFF = 0

BGSA144ML10 truth table allows to connect any combination of above bits in one single write to register_0 (respectively register_1) command. As an example RF1 series can be set ON while RF1 shunt is set OFF, RF2, RF3 and RF4 series set OFF and shunt set ON by using this single write to register_0 command «0b:11100001».

BGSA144ML10

Ultra High RF Voltage Antenna Tuning SP4T

Application Information

6 Application Information

Pin Configuration and Function

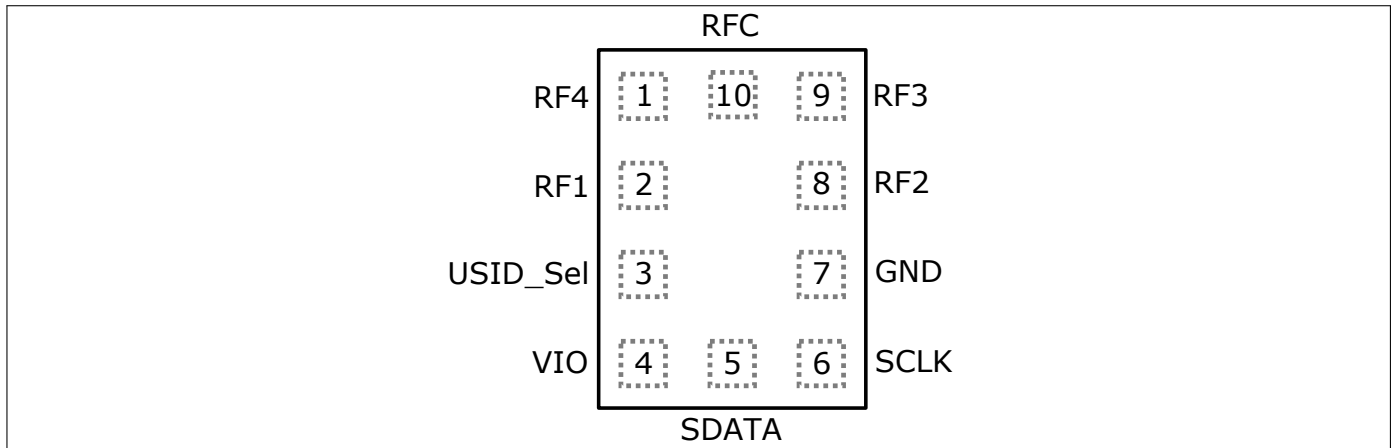

Figure 5: BGSA144ML10 Pin Configuration (top view)

Table 19: Pin Definition and Function

Pin No.	Name	Function
1	RF4	RF4 port
2	RF1	RF1 port
3	USID_Sel	USID default address selection pin (see Tab. 10)
4	VIO	Voltage supply compatible with MIPI RFFE specification
5	SDATA	MIPI RFFE data Input / Output
6	SCLK	MIPI RFFE clock Input
7	GND	Ground
8	RF2	RF2 port
9	RF3	RF3 port
10	RFC	Common RF port

BGSA144ML10

Ultra High RF Voltage Antenna Tuning SP4T

Application Information

Evaluation Board Description

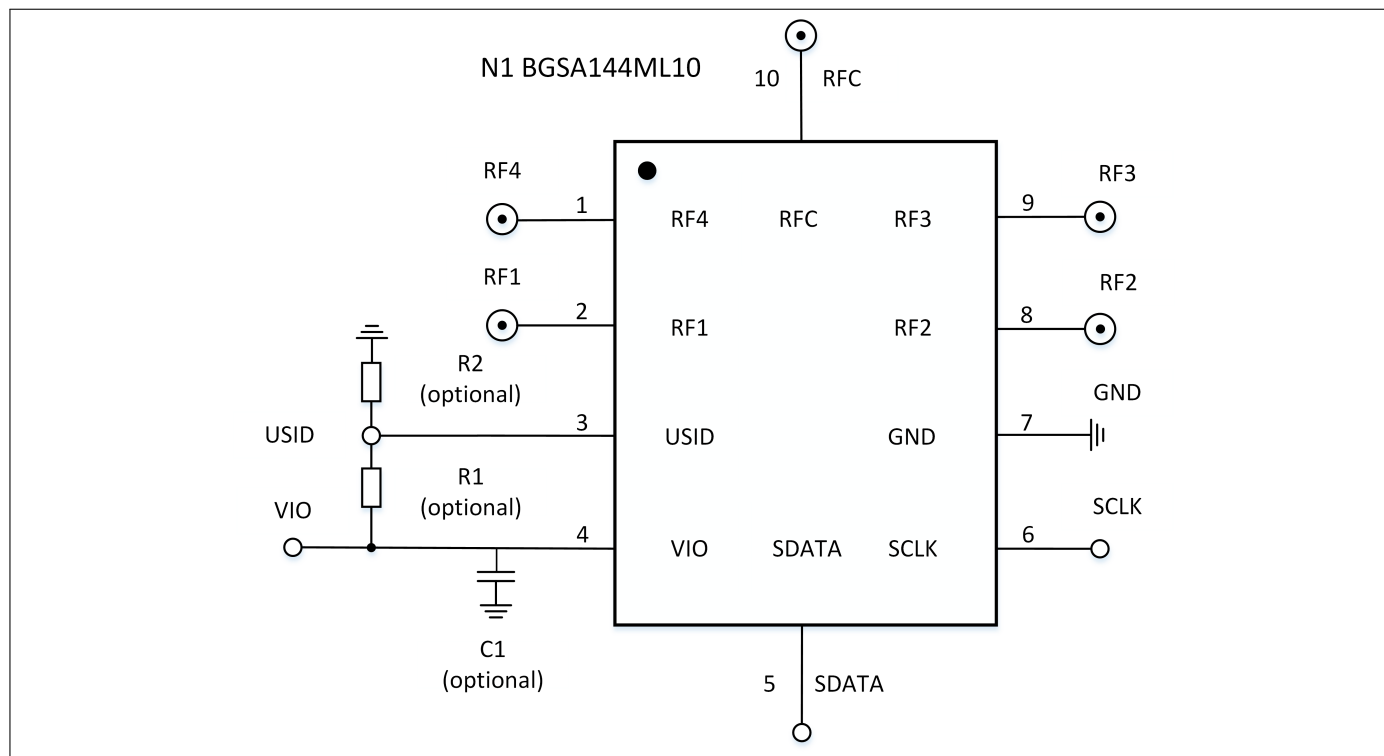

Figure 6: BGSA144ML10 Application Schematic

Table 20: Bill of Materials Table

Name	Part Type	Package	Manufacturer	Function
C1 (1nF optional) ¹⁾	Capacitor	0402	Various	De-coupling capacitor
N1	BGSA144ML10	TSLP-10-3	Infineon	Antenna Tuner
R1 (do not place) R2 (0 Ω)	Resistor	0402	Various	Set USID default Address to 6 (GND)
R1 (0 Ω) R2 (do not place)	Resistor	0402	Various	Set USID default Address to 7 (VIO)
R1 (220 kΩ) R2 (0 Ω)	Resistor	0402	Various	Set USID default Address to 8 (220 kΩ to VIO)
R1 (do not place) R2 (do not place)	Resistor	0402	Various	Set USID default Address to 9 (FLOATING)

¹⁾ This capacitor is optional and value is only indicative. Decoupling capacitor value has to be chosen in order VIO ramp-up time is within MIPI RFFE version v2.1 specification

BGSA144ML10

Ultra High RF Voltage Antenna Tuning SP4T

Package Information

7 Package Information

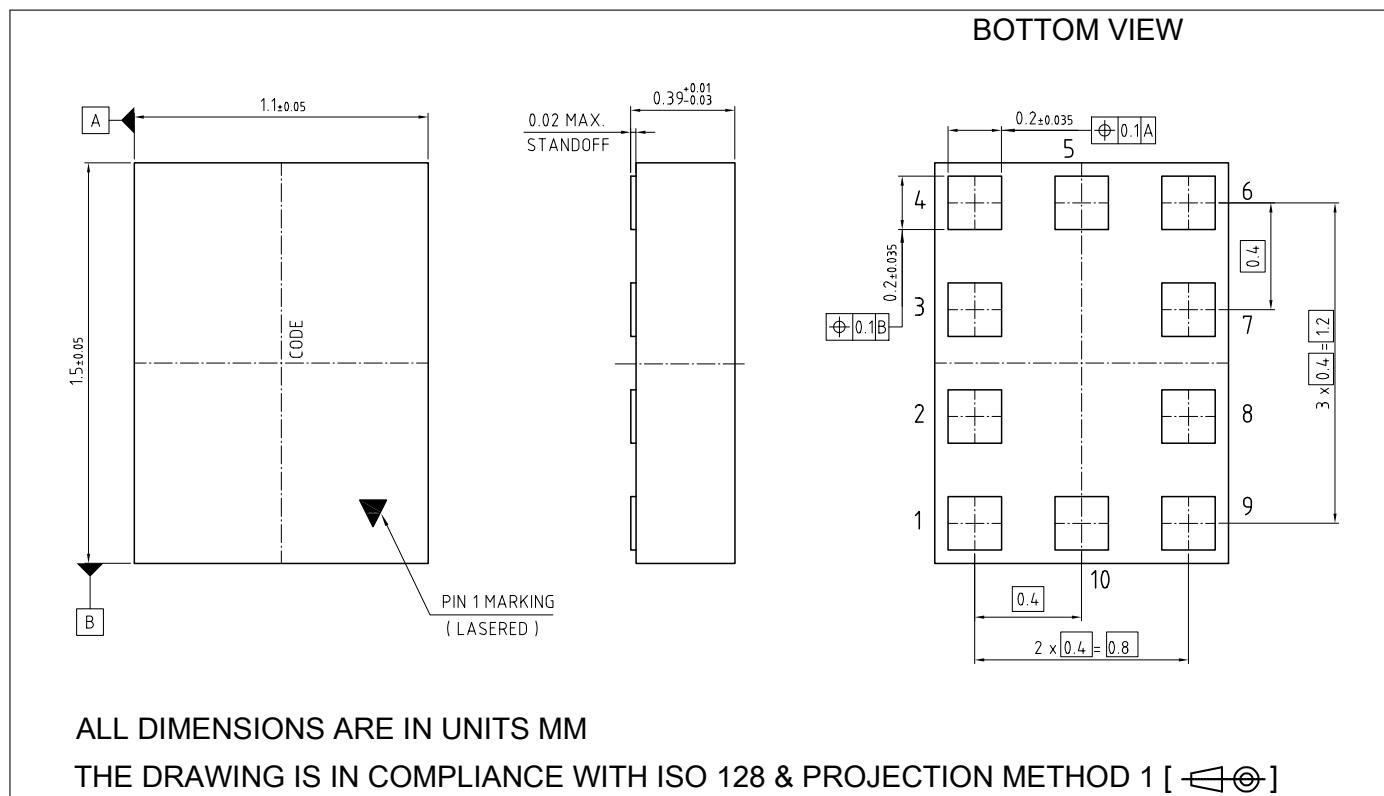

Figure 7: TSLP-10-3 Package Outline (top, side and bottom views)

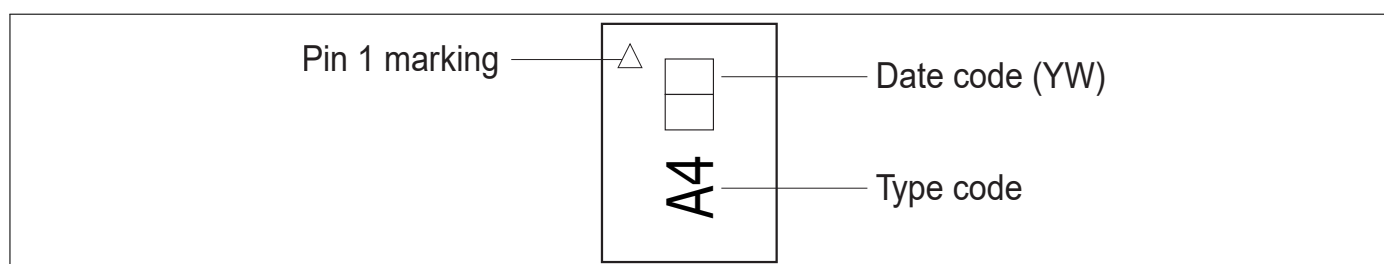

Figure 8: Marking Specification (top view): Date code digits Y and W defined in Table 21/22

Table 21: Year date code marking - digit "Y"

Year	"Y"	Year	"Y"	Year	"Y"
2010	0	2020	0	2030	0
2011	1	2021	1	2031	1
2012	2	2022	2	2032	2
2013	3	2023	3	2033	3
2014	4	2024	4	2034	4
2015	5	2025	5	2035	5
2016	6	2026	6	2036	6
2017	7	2027	7	2037	7
2018	8	2028	8	2038	8
2019	9	2029	9	2039	9

Table 22: Week date code marking - digit "W"

Week	"W"	Week	"W"	Week	"W"	Week	"W"	Week	"W"
1	A	12	N	23	4	34	h	45	v
2	B	13	P	24	5	35	j	46	x
3	C	14	Q	25	6	36	k	47	y
4	D	15	R	26	7	37	l	48	z
5	E	16	S	27	a	38	n	49	8
6	F	17	T	28	b	39	p	50	9
7	G	18	U	29	c	40	q	51	2
8	H	19	V	30	d	41	r	52	3
9	J	20	W	31	e	42	s	53	M
10	K	21	Y	32	f	43	t		
11	L	22	Z	33	g	44	u		

BGSA144ML10

Ultra High RF Voltage Antenna Tuning SP4T

Package Information

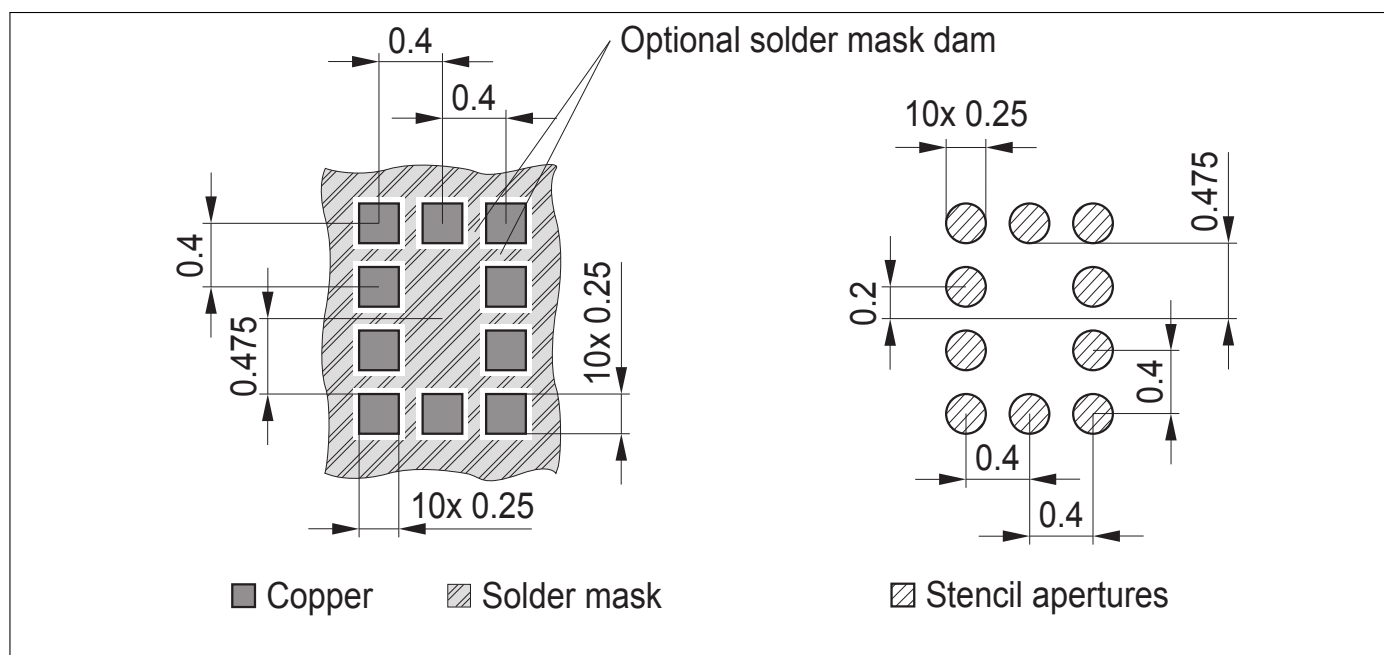

Figure 9: Footprint Recommendation (all dimensions are in units of mm)

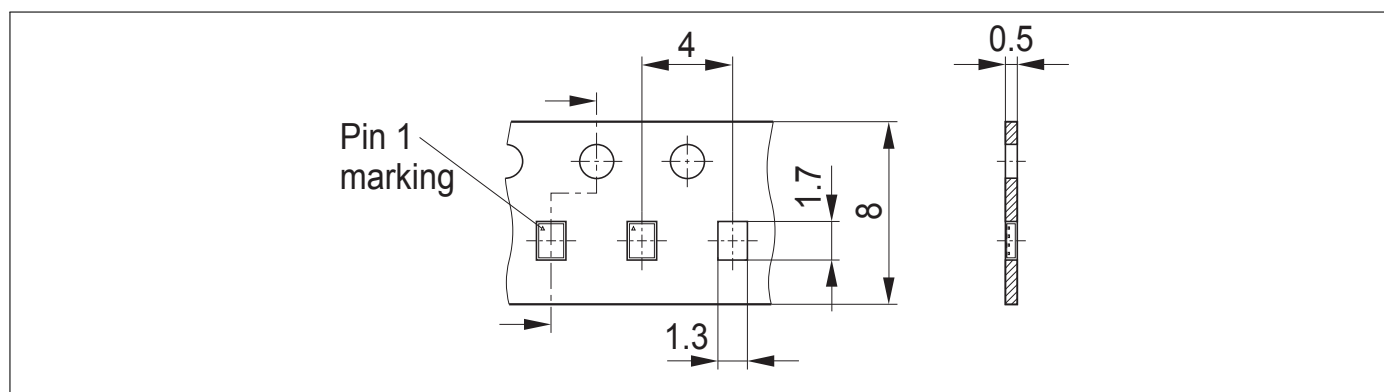

Figure 10: TSLP-10-3 Carrier Tape (all dimensions are in units of mm)

Trademarks

All referenced product or service names and trademarks are the property of their respective owners.

Edition 2024-04-18

Published by

Infineon Technologies AG

81726 Munich, Germany

© 2024 Infineon Technologies AG.

All Rights Reserved.

Do you have a question about any aspect of this document?

Email: erratum@infineon.com

IMPORTANT NOTICE

The information given in this document shall in no event be regarded as a guarantee of conditions or characteristics ("Beschaffheitsgarantie"). With respect to any examples, hints or any typical values stated herein and/or any information regarding the application of the product, Infineon Technologies hereby disclaims any and all warranties and liabilities of any kind, including without limitation warranties of non-infringement of intellectual property rights of any third party. In addition, any information given in this document is subject to customer's compliance with its obligations stated in this document and any applicable legal requirements, norms and standards concerning customer's products and any use of the product of Infineon Technologies in customer's applications. The data contained in this document is exclusively intended for technically trained staff. It is the responsibility of customer's technical departments to evaluate the suitability of the product for the intended application and the completeness of the product information given in this document with respect to such application.

For further information on technology, delivery terms and conditions and prices, please contact the nearest Infineon Technologies Office (www.infineon.com).



WARNINGS

Due to technical requirements products may contain dangerous substances. For information on the types in question please contact your nearest Infineon Technologies office.



Except as otherwise explicitly approved by Infineon Technologies in a written document signed by authorized representatives of Infineon Technologies, Infineon Technologies products may not be used in any applications where a failure of the product or any consequences of the use thereof can reasonably be expected to result in personal injury.

Looking for pricing, stock, or lifecycle information?

Click below to explore more details on WIN SOURCE:

-  [View BGSA144ML10E6327XTSA1 on WIN SOURCE](#)
-  [Infineon Technologies Information](#)

Optimize Your Supply Chain with WIN SOURCE Solutions

-  Global Sourcing Solution
-  Obsolete Management
-  Cost Control Management
-  Shortage Management
-  Alternative Solution
-  Excess Inventory Management