



**THE DATASHEET OF
L4931ABDT120R**



Very low drop voltage regulators with inhibit

Feature summary

- Very low dropout voltage (0.4V)
- Very low quiescent current
- (Typ. 50 μ A in off mode, 600 μ A in on mode)
- Output current up to 250 mA
- Logic-controlled electronic shutdown
- Output voltages of 1.5; 2.5; 2.7; 3; 3.3; 3.5; 4; 4.7; 5; 8; 12V
- Internal current and thermal limit
- Only 2.2 μ F for stability
- Available in \pm 1% (AB) or 2% (C) selection at 25°C
- Supply voltage rejection: 70db typ. for 5V version
- Temperature range: -40 to 125°C

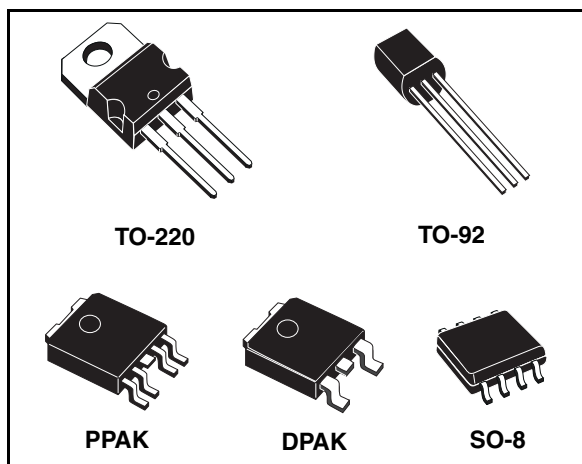

The very Low Drop voltage (0.4V) and the very low quiescent current make them particularly suitable for Low Noise, Low Power applications and specially in battery powered systems.

Description

The L4931 series are very Low Drop regulators available in TO-220, SO-8, DPAK, PPAK and TO-92 packages and in a wide range of output voltages.

In PPAK and SO-8 packages a Shutdown Logic Control function is available TTL compatible. This means that when the device is used as a local regulator, it is possible to put a part of the board in standby, decreasing the total power consumption. It requires only a 2.2 μ F capacitor for stability allowing space and cost saving.

Schematic diagram

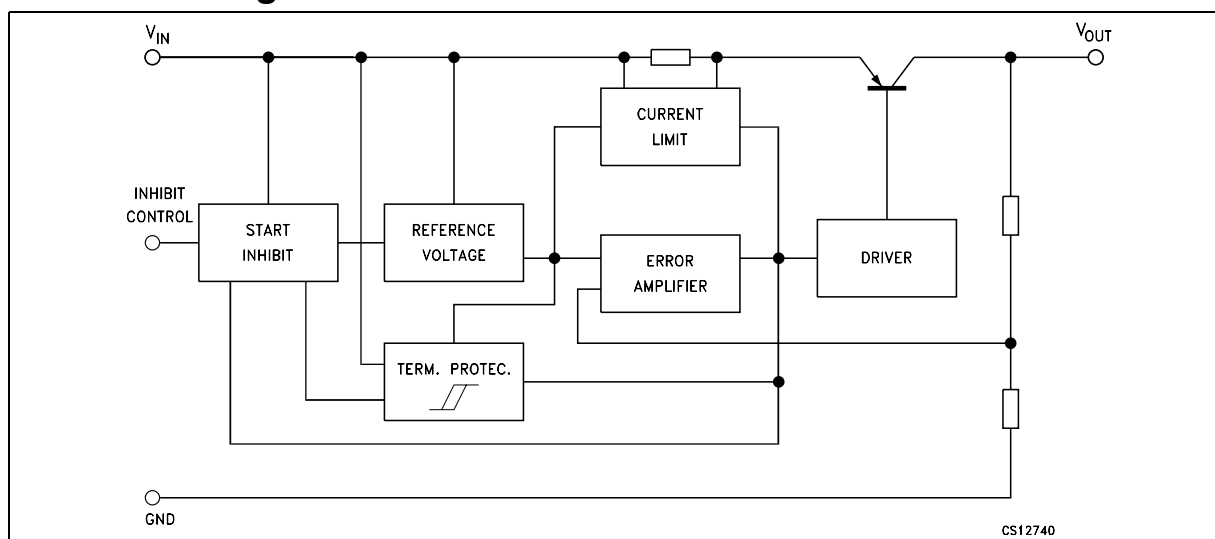

Contents

| | | |
|---|----------------------------------|----|
| 1 | Pin configuration | 3 |
| 2 | Maximum ratings | 4 |
| 3 | Application circuits | 5 |
| 4 | Electrical characteristics | 6 |
| 5 | Typical application | 28 |
| 6 | Package mechanical data | 29 |
| 7 | Order code | 38 |
| 8 | Revision history | 39 |

1 Pin configuration

Figure 1. Pin connections (top view)

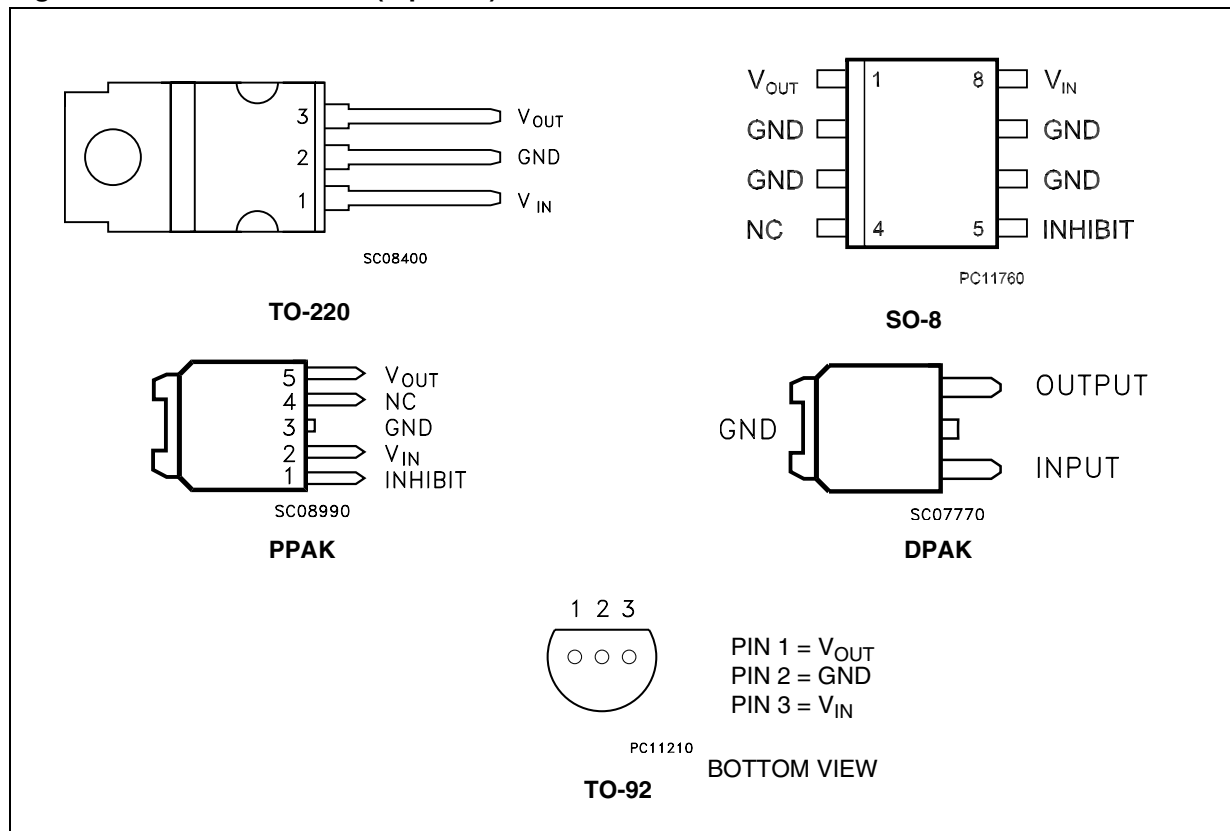

2 Maximum ratings

Table 1. Absolute maximum ratings

| Symbol | Parameter | Value | Unit |
|-----------|--------------------------------------|--------------------|------|
| V_I | DC Input voltage | 20 | V |
| I_O | Output current | Internally Limited | mA |
| P_D | Power dissipation | Internally Limited | mW |
| T_{STG} | Storage temperature range | -40 to 150 | °C |
| T_{OP} | Operating junction temperature range | -40 to 125 | °C |

Note: Absolute Maximum Ratings are those values beyond which damage to the device may occur. Functional operation under these condition is not implied

Table 2. Thermal Data

| Symbol | Parameter | TO-220 | SO-8 | DPAK | PPAK | TO-92 | Unit |
|------------|-------------------------------------|--------|------|------|------|-------|------|
| R_{thJC} | Thermal resistance junction-case | 3 | 20 | 8 | 8 | | °C/W |
| R_{thJA} | Thermal resistance junction-ambient | 50 | 55 | 100 | 100 | 200 | °C/W |

3 Application circuits

Figure 2. Test circuits

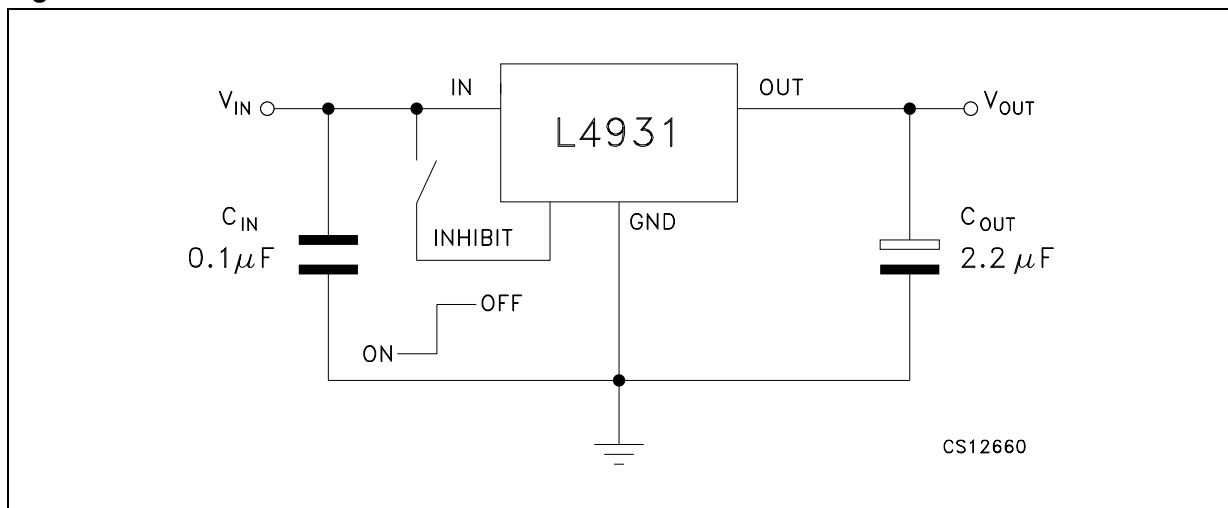

4 Electrical characteristics

Table 3. Electrical characteristics of L4931ABxx15 (refer to the test circuits, $T_J = 25^\circ\text{C}$, $C_I = 0.1 \mu\text{F}$, $C_O = 2.2 \mu\text{F}$ unless otherwise specified).

| Symbol | Parameter | Test conditions | Min. | Typ. | Max. | Unit |
|--------------|--------------------------------|--|----------------------|------|-------|---------------|
| V_O | Output voltage | $I_O = 5 \text{ mA}$, $V_I = 3.5 \text{ V}$ | 1.485 | 1.5 | 1.515 | V |
| | | $I_O = 5 \text{ mA}$, $V_I = 3.5 \text{ V}$, $T_A = -25$ to 85°C | 1.47 | | 1.53 | |
| V_I | Operating input voltage | $I_O = 250 \text{ mA}$ | 2.5 | | 20 | V |
| I_{out} | Output current limit | | | 300 | | mA |
| ΔV_O | Line regulation | $V_I = 2.5$ to 20 V , $I_O = 0.5 \text{ mA}$ | | 3 | 15 | mV |
| ΔV_O | Load regulation ⁽¹⁾ | $V_I = 2.7 \text{ V}$, $I_O = 0.5$ to 250 mA | | 3 | 15 | mV |
| I_d | Quiescent current ON MODE | $V_I = 2.7$ to 20 V , $I_O = 0 \text{ mA}$ | | 0.6 | 1 | mA |
| | | $V_I = 2.7$ to 20 V , $I_O = 250 \text{ mA}$ | | 4 | 6 | |
| | OFF MODE | $V_I = 6 \text{ V}$ | | 50 | 100 | μA |
| SVR | Supply voltage rejection | $I_O = 5 \text{ mA}$ $V_I = 3.7 \pm 1 \text{ V}$ | $f = 120 \text{ Hz}$ | | 79 | dB |
| | | | $f = 1 \text{ KHz}$ | | 76 | |
| | | | $f = 10 \text{ KHz}$ | | 55 | |
| eN | Output noise voltage | $B = 10 \text{ Hz}$ to 100 KHz | | 50 | | μV |
| V_d | Dropout voltage ⁽¹⁾ | $I_O = 250 \text{ mA}$ | | 1 | | V |
| V_{IL} | Control input logic low | $T_A = -40$ to 125°C | | | 0.8 | V |
| V_{IH} | Control Input Logic High | $T_A = -40$ to 125°C | 2 | | | V |
| I_I | Control input current | $V_I = 6 \text{ V}$, $V_C = 6 \text{ V}$ | | 10 | | μA |
| C_O | Output bypass capacitance | $\text{ESR} = 0.1$ to 10Ω , $I_O = 0$ to 250 mA | 2 | 10 | | μF |

1. For SO-8 package the maximum limit of load regulation and dropout is increased by 20 mV.

Table 4. Electrical characteristics of L4931Cxx15 (refer to the test circuits, $T_J = 25^\circ\text{C}$, $C_I = 0.1 \mu\text{F}$, $C_O = 2.2 \mu\text{F}$ unless otherwise specified).

| Symbol | Parameter | Test conditions | Min. | Typ. | Max. | Unit |
|------------------|--------------------------------|---|----------------------|------|------|---------------|
| V_O | Output voltage | $I_O = 5 \text{ mA}$, $V_I = 3.5 \text{ V}$ | 1.47 | 1.5 | 1.53 | V |
| | | $I_O = 5 \text{ mA}$, $V_I = 3.5 \text{ V}$, $T_A = -25 \text{ to } 85^\circ\text{C}$ | 1.44 | | 1.56 | |
| V_I | Operating input voltage | $I_O = 250 \text{ mA}$ | 2.5 | | 20 | V |
| I_{out} | Output current limit | | | 300 | | mA |
| ΔV_O | Line regulation | $V_I = 2.5 \text{ to } 20 \text{ V}$, $I_O = 0.5 \text{ mA}$ | | 3 | 18 | mV |
| ΔV_O | Load regulation ⁽¹⁾ | $V_I = 2.7 \text{ V}$, $I_O = 0.5 \text{ to } 250 \text{ mA}$ | | 3 | 18 | mV |
| I_d | Quiescent current ON MODE | $V_I = 2.7 \text{ to } 20 \text{ V}$, $I_O = 0 \text{ mA}$ | | 0.6 | 1 | mA |
| | | $V_I = 2.7 \text{ to } 20 \text{ V}$, $I_O = 250 \text{ mA}$ | | 4 | 6 | |
| | OFF MODE | $V_I = 6 \text{ V}$ | | 50 | 100 | μA |
| SVR | Supply voltage rejection | $I_O = 5 \text{ mA}$ $V_I = 3.7 \pm 1 \text{ V}$ | $f = 120 \text{ Hz}$ | | 79 | dB |
| | | | $f = 1 \text{ KHz}$ | | 76 | |
| | | | $f = 10 \text{ KHz}$ | | 55 | |
| eN | Output noise voltage | $B = 10 \text{ Hz to } 100 \text{ KHz}$ | | 50 | | μV |
| V_d | Dropout voltage ⁽¹⁾ | $I_O = 250 \text{ mA}$ | | 1 | | V |
| V_{IL} | Control input logic low | $T_A = -40 \text{ to } 125^\circ\text{C}$ | | | 0.8 | V |
| V_{IH} | Control Input Logic High | $T_A = -40 \text{ to } 125^\circ\text{C}$ | 2 | | | V |
| I_I | Control input current | $V_I = 6 \text{ V}$, $V_C = 6 \text{ V}$ | | 10 | | μA |
| C_O | Output bypass capacitance | $\text{ESR} = 0.1 \text{ to } 10 \Omega$, $I_O = 0 \text{ to } 250 \text{ mA}$ | 2 | 10 | | μF |

1. For SO-8 package the maximum limit of load regulation and dropout is increased by 20 mV.

Table 5. Electrical characteristics of L4931ABxx25 (refer to the test circuits, $T_J = 25^\circ\text{C}$, $C_I = 0.1 \mu\text{F}$, $C_O = 2.2 \mu\text{F}$ unless otherwise specified).

| Symbol | Parameter | Test conditions | Min. | Typ. | Max. | Unit |
|--------------|--------------------------------|---|----------------------|------|-------|---------------|
| V_O | Output voltage | $I_O = 5 \text{ mA}$, $V_I = 4.5 \text{ V}$ | 2.475 | 2.5 | 2.525 | V |
| | | $I_O = 5 \text{ mA}$, $V_I = 4.5 \text{ V}$, $T_A = -25 \text{ to } 85^\circ\text{C}$ | 2.45 | | 2.55 | |
| V_I | Operating input voltage | $I_O = 250 \text{ mA}$ | | | 20 | V |
| I_{out} | Output current limit | | | 300 | | mA |
| ΔV_O | Line regulation | $V_I = 3.2 \text{ to } 20 \text{ V}$, $I_O = 0.5 \text{ mA}$ | | 3 | 15 | mV |
| ΔV_O | Load regulation ⁽¹⁾ | $V_I = 3.4 \text{ V}$, $I_O = 0.5 \text{ to } 250 \text{ mA}$ | | 3 | 15 | mV |
| I_d | Quiescent current ON MODE | $V_I = 3.4 \text{ to } 20 \text{ V}$, $I_O = 0 \text{ mA}$ | | 0.6 | 1 | mA |
| | | $V_I = 3.4 \text{ to } 20 \text{ V}$, $I_O = 250 \text{ mA}$ | | 4 | 6 | |
| | OFF MODE | $V_I = 6 \text{ V}$ | | 50 | 100 | μA |
| SVR | Supply voltage rejection | $I_O = 5 \text{ mA}$ $V_I = 4.4 \pm 1 \text{ V}$ | $f = 120 \text{ Hz}$ | | 75 | dB |
| | | | $f = 1 \text{ KHz}$ | | 72 | |
| | | | $f = 10 \text{ KHz}$ | | 55 | |
| eN | Output noise voltage | $B = 10 \text{ Hz to } 100 \text{ KHz}$ | | 50 | | μV |
| V_d | Dropout voltage ⁽¹⁾ | $I_O = 250 \text{ mA}$ | | 0.4 | 0.6 | V |
| | | $I_O = 250 \text{ mA}$, $T_A = -40 \text{ to } 125^\circ\text{C}$ | | | 0.8 | V |
| V_{IL} | Control input logic low | $T_A = -40 \text{ to } 125^\circ\text{C}$ | | | 0.8 | V |
| V_{IH} | Control Input Logic High | $T_A = -40 \text{ to } 125^\circ\text{C}$ | 2 | | | V |
| I_I | Control input current | $V_I = 6 \text{ V}$, $V_C = 6 \text{ V}$ | | 10 | | μA |
| C_O | Output bypass capacitance | $\text{ESR} = 0.1 \text{ to } 10 \Omega$, $I_O = 0 \text{ to } 250 \text{ mA}$ | 2 | 10 | | μF |

1. For SO-8 package the maximum limit of load regulation and dropout is increased by 20 mV.

Table 6. Electrical characteristics of L4931Cxx25 (refer to the test circuits, $T_J = 25^\circ\text{C}$, $C_I = 0.1 \mu\text{F}$, $C_O = 2.2 \mu\text{F}$ unless otherwise specified).

| Symbol | Parameter | Test conditions | Min. | Typ. | Max. | Unit |
|------------------|--------------------------------|---|----------------------|------|------|---------------|
| V_O | Output voltage | $I_O = 5 \text{ mA}$, $V_I = 4.5 \text{ V}$ | 2.45 | 2.5 | 2.55 | V |
| | | $I_O = 5 \text{ mA}$, $V_I = 4.5 \text{ V}$, $T_A = -25 \text{ to } 85^\circ\text{C}$ | 2.4 | | 2.6 | |
| V_I | Operating input voltage | $I_O = 250 \text{ mA}$ | | | 20 | V |
| I_{out} | Output current limit | | | 300 | | mA |
| ΔV_O | Line regulation | $V_I = 3.3 \text{ to } 20 \text{ V}$, $I_O = 0.5 \text{ mA}$ | | 3 | 18 | mV |
| ΔV_O | Load regulation ⁽¹⁾ | $V_I = 3.5 \text{ V}$, $I_O = 0.5 \text{ to } 250 \text{ mA}$ | | 3 | 18 | mV |
| I_d | Quiescent current ON MODE | $V_I = 3.5 \text{ to } 20 \text{ V}$, $I_O = 0 \text{ mA}$ | | 0.6 | 1 | mA |
| | | $V_I = 3.5 \text{ to } 20 \text{ V}$, $I_O = 250 \text{ mA}$ | | 4 | 6 | |
| | OFF MODE | $V_I = 6 \text{ V}$ | | 50 | 100 | μA |
| SVR | Supply voltage rejection | $I_O = 5 \text{ mA}$ $V_I = 4.4 \pm 1 \text{ V}$ | $f = 120 \text{ Hz}$ | | 75 | dB |
| | | | $f = 1 \text{ KHz}$ | | 72 | |
| | | | $f = 10 \text{ KHz}$ | | 55 | |
| eN | Output noise voltage | $B = 10 \text{ Hz to } 100 \text{ KHz}$ | | 50 | | μV |
| V_d | Dropout voltage ⁽¹⁾ | $I_O = 250 \text{ mA}$ | | 0.4 | 0.6 | V |
| | | $I_O = 250 \text{ mA}$, $T_A = -40 \text{ to } 125^\circ\text{C}$ | | | 0.8 | V |
| V_{IL} | Control input logic low | $T_A = -40 \text{ to } 125^\circ\text{C}$ | | | 0.8 | V |
| V_{IH} | Control Input Logic High | $T_A = -40 \text{ to } 125^\circ\text{C}$ | 2 | | | V |
| I_I | Control input current | $V_I = 6 \text{ V}$, $V_C = 6 \text{ V}$ | | 10 | | μA |
| C_O | Output bypass capacitance | $\text{ESR} = 0.1 \text{ to } 10 \Omega$, $I_O = 0 \text{ to } 250 \text{ mA}$ | 2 | 10 | | μF |

1. For SO-8 package the maximum limit of load regulation and dropout is increased by 20 mV.

Table 7. Electrical characteristics of L4931ABxx27 (refer to the test circuits, $T_J = 25^\circ\text{C}$, $C_I = 0.1 \mu\text{F}$, $C_O = 2.2 \mu\text{F}$ unless otherwise specified).

| Symbol | Parameter | Test conditions | Min. | Typ. | Max. | Unit |
|------------------|--------------------------------|---|----------------------|------|-------|---------------|
| V_O | Output voltage | $I_O = 5 \text{ mA}$, $V_I = 4.7 \text{ V}$ | 2.673 | 2.7 | 2.727 | V |
| | | $I_O = 5 \text{ mA}$, $V_I = 4.7 \text{ V}$, $T_A = -25 \text{ to } 85^\circ\text{C}$ | 2.646 | | 2.754 | |
| V_I | Operating input voltage | $I_O = 250 \text{ mA}$ | | | 20 | V |
| I_{out} | Output current limit | | | 300 | | mA |
| ΔV_O | Line regulation | $V_I = 3.4 \text{ to } 20 \text{ V}$, $I_O = 0.5 \text{ mA}$ | | 3 | 15 | mV |
| ΔV_O | Load regulation ⁽¹⁾ | $V_I = 3.6 \text{ V}$, $I_O = 0.5 \text{ to } 250 \text{ mA}$ | | 3 | 15 | mV |
| I_d | Quiescent current ON MODE | $V_I = 3.6 \text{ to } 20 \text{ V}$, $I_O = 0 \text{ mA}$ | | 0.6 | 1 | mA |
| | | $V_I = 3.6 \text{ to } 20 \text{ V}$, $I_O = 250 \text{ mA}$ | | 4 | 6 | |
| | OFF MODE | $V_I = 6 \text{ V}$ | | 50 | 100 | μA |
| SVR | Supply voltage rejection | $I_O = 5 \text{ mA}$ $V_I = 4.6 \pm 1 \text{ V}$ | $f = 120 \text{ Hz}$ | | 74 | dB |
| | | | $f = 1 \text{ KHz}$ | | 71 | |
| | | | $f = 10 \text{ KHz}$ | | 55 | |
| eN | Output noise voltage | B = 10 Hz to 100 KHz | | 50 | | μV |
| V_d | Dropout voltage ⁽¹⁾ | $I_O = 250 \text{ mA}$ | | 0.4 | 0.6 | V |
| | | $I_O = 250 \text{ mA}$, $T_A = -40 \text{ to } 125^\circ\text{C}$ | | | 0.8 | V |
| V_{IL} | Control input logic low | $T_A = -40 \text{ to } 125^\circ\text{C}$ | | | 0.8 | V |
| V_{IH} | Control Input Logic High | $T_A = -40 \text{ to } 125^\circ\text{C}$ | 2 | | | V |
| I_I | Control input current | $V_I = 6 \text{ V}$, $V_C = 6 \text{ V}$ | | 10 | | μA |
| C_O | Output bypass capacitance | ESR = 0.1 to 10 Ω , $I_O = 0 \text{ to } 250 \text{ mA}$ | 2 | 10 | | μF |

1. For SO-8 package the maximum limit of load regulation and dropout is increased by 20 mV.

Table 8. Electrical characteristics of L4931Cxx27 (refer to the test circuits, $T_J = 25^\circ\text{C}$, $C_I = 0.1 \mu\text{F}$, $C_O = 2.2 \mu\text{F}$ unless otherwise specified).

| Symbol | Parameter | Test conditions | Min. | Typ. | Max. | Unit |
|------------------|--------------------------------|---|----------------------|------|-------|---------------|
| V_O | Output voltage | $I_O = 5 \text{ mA}$, $V_I = 4.7 \text{ V}$ | 2.646 | 2.7 | 2.754 | V |
| | | $I_O = 5 \text{ mA}$, $V_I = 4.7 \text{ V}$, $T_A = -25 \text{ to } 85^\circ\text{C}$ | 2.592 | | 2.808 | |
| V_I | Operating input voltage | $I_O = 250 \text{ mA}$ | | | 20 | V |
| I_{out} | Output current limit | | | 300 | | mA |
| ΔV_O | Line regulation | $V_I = 3.4 \text{ to } 20 \text{ V}$, $I_O = 0.5 \text{ mA}$ | | 3 | 18 | mV |
| ΔV_O | Load regulation ⁽¹⁾ | $V_I = 3.6 \text{ V}$, $I_O = 0.5 \text{ to } 250 \text{ mA}$ | | 3 | 18 | mV |
| I_d | Quiescent current ON MODE | $V_I = 3.6 \text{ to } 20 \text{ V}$, $I_O = 0 \text{ mA}$ | | 0.6 | 1 | mA |
| | | $V_I = 3.6 \text{ to } 20 \text{ V}$, $I_O = 250 \text{ mA}$ | | 4 | 6 | |
| | OFF MODE | $V_I = 6 \text{ V}$ | | 50 | 100 | μA |
| SVR | Supply voltage rejection | $I_O = 5 \text{ mA}$ $V_I = 4.6 \pm 1 \text{ V}$ | $f = 120 \text{ Hz}$ | | 74 | dB |
| | | | $f = 1 \text{ KHz}$ | | 71 | |
| | | | $f = 10 \text{ KHz}$ | | 55 | |
| eN | Output noise voltage | $B = 10 \text{ Hz to } 100 \text{ KHz}$ | | 50 | | μV |
| V_d | Dropout voltage ⁽¹⁾ | $I_O = 250 \text{ mA}$ | | 0.4 | 0.6 | V |
| | | $I_O = 250 \text{ mA}$, $T_A = -40 \text{ to } 125^\circ\text{C}$ | | | 0.8 | V |
| V_{IL} | Control input logic low | $T_A = -40 \text{ to } 125^\circ\text{C}$ | | | 0.8 | V |
| V_{IH} | Control Input Logic High | $T_A = -40 \text{ to } 125^\circ\text{C}$ | 2 | | | V |
| I_I | Control input current | $V_I = 6 \text{ V}$, $V_C = 6 \text{ V}$ | | 10 | | μA |
| C_O | Output bypass capacitance | $\text{ESR} = 0.1 \text{ to } 10 \Omega$, $I_O = 0 \text{ to } 250 \text{ mA}$ | 2 | 10 | | μF |

1. For SO-8 package the maximum limit of load regulation and dropout is increased by 20 mV.

Table 9. Electrical characteristics of L4931ABxx30 (refer to the test circuits, $T_J = 25^\circ\text{C}$, $C_I = 0.1 \mu\text{F}$, $C_O = 2.2 \mu\text{F}$ unless otherwise specified).

| Symbol | Parameter | Test conditions | Min. | Typ. | Max. | Unit |
|--------------|--------------------------------|---|----------------------|------|------|---------------|
| V_O | Output voltage | $I_O = 5 \text{ mA}$, $V_I = 5 \text{ V}$ | 2.97 | 3 | 3.03 | V |
| | | $I_O = 5 \text{ mA}$, $V_I = 5 \text{ V}$, $T_A = -25 \text{ to } 85^\circ\text{C}$ | 2.94 | | 3.06 | |
| V_I | Operating input voltage | $I_O = 250 \text{ mA}$ | | | 20 | V |
| I_{out} | Output current limit | | | 300 | | mA |
| ΔV_O | Line regulation | $V_I = 3.7 \text{ to } 20 \text{ V}$, $I_O = 0.5 \text{ mA}$ | | 3 | 15 | mV |
| ΔV_O | Load regulation ⁽¹⁾ | $V_I = 3.9 \text{ V}$, $I_O = 0.5 \text{ to } 250 \text{ mA}$ | | 3 | 15 | mV |
| I_d | Quiescent current ON MODE | $V_I = 3.9 \text{ to } 20 \text{ V}$, $I_O = 0 \text{ mA}$ | | 0.6 | 1 | mA |
| | | $V_I = 3.9 \text{ to } 20 \text{ V}$, $I_O = 250 \text{ mA}$ | | 4 | 6 | |
| | OFF MODE | $V_I = 6 \text{ V}$ | | 50 | 100 | μA |
| SVR | Supply voltage rejection | $I_O = 5 \text{ mA}$ $V_I = 4.9 \pm 1 \text{ V}$ | $f = 120 \text{ Hz}$ | | 74 | dB |
| | | | $f = 1 \text{ KHz}$ | | 71 | |
| | | | $f = 10 \text{ KHz}$ | | 55 | |
| eN | Output noise voltage | $B = 10 \text{ Hz to } 100 \text{ KHz}$ | | 50 | | μV |
| V_d | Dropout voltage ⁽¹⁾ | $I_O = 250 \text{ mA}$ | | 0.4 | 0.6 | V |
| | | $I_O = 250 \text{ mA}$, $T_A = -40 \text{ to } 125^\circ\text{C}$ | | | 0.8 | V |
| V_{IL} | Control input logic low | $T_A = -40 \text{ to } 125^\circ\text{C}$ | | | 0.8 | V |
| V_{IH} | Control Input Logic High | $T_A = -40 \text{ to } 125^\circ\text{C}$ | 2 | | | V |
| I_I | Control input current | $V_I = 6 \text{ V}$, $V_C = 6 \text{ V}$ | | 10 | | μA |
| C_O | Output bypass capacitance | $\text{ESR} = 0.1 \text{ to } 10 \Omega$, $I_O = 0 \text{ to } 250 \text{ mA}$ | 2 | 10 | | μF |

1. For SO-8 package the maximum limit of load regulation and dropout is increased by 20 mV.

Table 10. Electrical characteristics of L4931Cxx30 (refer to the test circuits, $T_J = 25^\circ\text{C}$, $C_I = 0.1 \mu\text{F}$, $C_O = 2.2 \mu\text{F}$ unless otherwise specified).

| Symbol | Parameter | Test conditions | Min. | Typ. | Max. | Unit |
|------------------|--------------------------------|---|----------------------|------|------|---------------|
| V_O | Output voltage | $I_O = 5 \text{ mA}$, $V_I = 5 \text{ V}$ | 2.94 | 3 | 3.06 | V |
| | | $I_O = 5 \text{ mA}$, $V_I = 5 \text{ V}$, $T_A = -25 \text{ to } 85^\circ\text{C}$ | 2.88 | | 3.12 | |
| V_I | Operating input voltage | $I_O = 250 \text{ mA}$ | | | 20 | V |
| I_{out} | Output current limit | | | 300 | | mA |
| ΔV_O | Line regulation | $V_I = 3.8 \text{ to } 20 \text{ V}$, $I_O = 0.5 \text{ mA}$ | | 3 | 18 | mV |
| ΔV_O | Load regulation ⁽¹⁾ | $V_I = 4 \text{ V}$, $I_O = 0.5 \text{ to } 250 \text{ mA}$ | | 3 | 18 | mV |
| I_d | Quiescent current ON MODE | $V_I = 4 \text{ to } 20 \text{ V}$, $I_O = 0 \text{ mA}$ | | 0.6 | 1 | mA |
| | | $V_I = 4 \text{ to } 20 \text{ V}$, $I_O = 250 \text{ mA}$ | | 4 | 6 | |
| | OFF MODE | $V_I = 6 \text{ V}$ | | 50 | 100 | μA |
| SVR | Supply voltage rejection | $I_O = 5 \text{ mA}$ $V_I = 5 \pm 1 \text{ V}$ | $f = 120 \text{ Hz}$ | | 74 | dB |
| | | | $f = 1 \text{ KHz}$ | | 71 | |
| | | | $f = 10 \text{ KHz}$ | | 55 | |
| eN | Output noise voltage | $B = 10 \text{ Hz to } 100 \text{ KHz}$ | | 50 | | μV |
| V_d | Dropout voltage ⁽¹⁾ | $I_O = 250 \text{ mA}$ | | 0.4 | 0.6 | V |
| | | $I_O = 250 \text{ mA}$, $T_A = -40 \text{ to } 125^\circ\text{C}$ | | | 0.8 | V |
| V_{IL} | Control input logic low | $T_A = -40 \text{ to } 125^\circ\text{C}$ | | | 0.8 | V |
| V_{IH} | Control Input Logic High | $T_A = -40 \text{ to } 125^\circ\text{C}$ | 2 | | | V |
| I_I | Control input current | $V_I = 6 \text{ V}$, $V_C = 6 \text{ V}$ | | 10 | | μA |
| C_O | Output bypass capacitance | $\text{ESR} = 0.1 \text{ to } 10 \Omega$, $I_O = 0 \text{ to } 250 \text{ mA}$ | 2 | 10 | | μF |

1. For SO-8 package the maximum limit of load regulation and dropout is increased by 20 mV.

Table 11. Electrical characteristics of L4931ABxx33 (refer to the test circuits, $T_J = 25^\circ\text{C}$, $C_I = 0.1 \mu\text{F}$, $C_O = 2.2 \mu\text{F}$ unless otherwise specified).

| Symbol | Parameter | Test conditions | Min. | Typ. | Max. | Unit |
|--------------|--------------------------------|---|----------------------|------|-------|---------------|
| V_O | Output voltage | $I_O = 5 \text{ mA}$, $V_I = 5.3 \text{ V}$ | 3.267 | 3.3 | 3.333 | V |
| | | $I_O = 5 \text{ mA}$, $V_I = 5.3 \text{ V}$, $T_A = -25 \text{ to } 85^\circ\text{C}$ | 3.234 | | 3.366 | |
| V_I | Operating input voltage | $I_O = 250 \text{ mA}$ | | | 20 | V |
| I_{out} | Output current limit | | | 300 | | mA |
| ΔV_O | Line regulation | $V_I = 4 \text{ to } 20 \text{ V}$, $I_O = 0.5 \text{ mA}$ | | 3 | 15 | mV |
| ΔV_O | Load regulation ⁽¹⁾ | $V_I = 4.2 \text{ V}$, $I_O = 0.5 \text{ to } 250 \text{ mA}$ | | 3 | 15 | mV |
| I_d | Quiescent current ON MODE | $V_I = 4.2 \text{ to } 20 \text{ V}$, $I_O = 0 \text{ mA}$ | | 0.6 | 1 | mA |
| | | $V_I = 4.2 \text{ to } 20 \text{ V}$, $I_O = 250 \text{ mA}$ | | 4 | 6 | |
| | OFF MODE | $V_I = 6 \text{ V}$ | | 50 | 100 | μA |
| SVR | Supply voltage rejection | $I_O = 5 \text{ mA}$ $V_I = 5.2 \pm 1 \text{ V}$ | $f = 120 \text{ Hz}$ | | 73 | dB |
| | | | $f = 1 \text{ KHz}$ | | 70 | |
| | | | $f = 10 \text{ KHz}$ | | 55 | |
| eN | Output noise voltage | $B = 10 \text{ Hz to } 100 \text{ KHz}$ | | 50 | | μV |
| V_d | Dropout voltage ⁽¹⁾ | $I_O = 250 \text{ mA}$ | | 0.4 | 0.6 | V |
| | | $I_O = 250 \text{ mA}$, $T_A = -40 \text{ to } 125^\circ\text{C}$ | | | 0.8 | V |
| V_{IL} | Control input logic low | $T_A = -40 \text{ to } 125^\circ\text{C}$ | | | 0.8 | V |
| V_{IH} | Control Input Logic High | $T_A = -40 \text{ to } 125^\circ\text{C}$ | 2 | | | V |
| I_I | Control input current | $V_I = 6 \text{ V}$, $V_C = 6 \text{ V}$ | | 10 | | μA |
| C_O | Output bypass capacitance | $\text{ESR} = 0.1 \text{ to } 10 \Omega$, $I_O = 0 \text{ to } 250 \text{ mA}$ | 2 | 10 | | μF |

1. For SO-8 package the maximum limit of load regulation and dropout is increased by 20 mV.

Table 12. Electrical characteristics of L4931Cxx33 (refer to the test circuits, $T_J = 25^\circ\text{C}$, $C_I = 0.1 \mu\text{F}$, $C_O = 2.2 \mu\text{F}$ unless otherwise specified).

| Symbol | Parameter | Test conditions | Min. | Typ. | Max. | Unit |
|------------------|--------------------------------|---|----------------------|------|-------|---------------|
| V_O | Output voltage | $I_O = 5 \text{ mA}$, $V_I = 5.3 \text{ V}$ | 3.234 | 3.3 | 3.366 | V |
| | | $I_O = 5 \text{ mA}$, $V_I = 5.3 \text{ V}$, $T_A = -25 \text{ to } 85^\circ\text{C}$ | 3.168 | | 3.432 | |
| V_I | Operating input voltage | $I_O = 250 \text{ mA}$ | | | 20 | V |
| I_{out} | Output current limit | | | 300 | | mA |
| ΔV_O | Line regulation | $V_I = 4.1 \text{ to } 20 \text{ V}$, $I_O = 0.5 \text{ mA}$ | | 3 | 18 | mV |
| ΔV_O | Load regulation ⁽¹⁾ | $V_I = 4.3 \text{ V}$, $I_O = 0.5 \text{ to } 250 \text{ mA}$ | | 3 | 18 | mV |
| I_d | Quiescent current ON MODE | $V_I = 4.3 \text{ to } 20 \text{ V}$, $I_O = 0 \text{ mA}$ | | 0.6 | 1 | mA |
| | | $V_I = 4.3 \text{ to } 20 \text{ V}$, $I_O = 250 \text{ mA}$ | | 4 | 6 | |
| | OFF MODE | $V_I = 6 \text{ V}$ | | 50 | 100 | μA |
| SVR | Supply voltage rejection | $I_O = 5 \text{ mA}$ $V_I = 5.3 \pm 1 \text{ V}$ | $f = 120 \text{ Hz}$ | | 73 | dB |
| | | | $f = 1 \text{ KHz}$ | | 70 | |
| | | | $f = 10 \text{ KHz}$ | | 55 | |
| eN | Output noise voltage | $B = 10 \text{ Hz to } 100 \text{ KHz}$ | | 50 | | μV |
| V_d | Dropout voltage ⁽¹⁾ | $I_O = 250 \text{ mA}$ | | 0.4 | 0.6 | V |
| | | $I_O = 250 \text{ mA}$, $T_A = -40 \text{ to } 125^\circ\text{C}$ | | | 0.8 | V |
| V_{IL} | Control input logic low | $T_A = -40 \text{ to } 125^\circ\text{C}$ | | | 0.8 | V |
| V_{IH} | Control Input Logic High | $T_A = -40 \text{ to } 125^\circ\text{C}$ | 2 | | | V |
| I_I | Control input current | $V_I = 6 \text{ V}$, $V_C = 6 \text{ V}$ | | 10 | | μA |
| C_O | Output bypass capacitance | $\text{ESR} = 0.1 \text{ to } 10 \Omega$, $I_O = 0 \text{ to } 250 \text{ mA}$ | 2 | 10 | | μF |

1. For SO-8 package the maximum limit of load regulation and dropout is increased by 20 mV.

Table 13. Electrical characteristics of L4931ABxx35 (refer to the test circuits, $T_J = 25^\circ\text{C}$, $C_I = 0.1 \mu\text{F}$, $C_O = 2.2 \mu\text{F}$ unless otherwise specified).

| Symbol | Parameter | Test conditions | Min. | Typ. | Max. | Unit |
|------------------|--------------------------------|---|----------------------|------|-------|---------------|
| V_O | Output voltage | $I_O = 5 \text{ mA}$, $V_I = 5.5 \text{ V}$ | 3.465 | 3.5 | 3.535 | V |
| | | $I_O = 5 \text{ mA}$, $V_I = 5.5 \text{ V}$, $T_A = -25 \text{ to } 85^\circ\text{C}$ | 3.43 | | 3.57 | |
| V_I | Operating input voltage | $I_O = 250 \text{ mA}$ | | | 20 | V |
| I_{out} | Output current limit | | | 300 | | mA |
| ΔV_O | Line regulation | $V_I = 4.2 \text{ to } 20 \text{ V}$, $I_O = 0.5 \text{ mA}$ | | 3 | 15 | mV |
| ΔV_O | Load regulation ⁽¹⁾ | $V_I = 4.4 \text{ V}$, $I_O = 0.5 \text{ to } 250 \text{ mA}$ | | 3 | 15 | mV |
| I_d | Quiescent current ON MODE | $V_I = 4.4 \text{ to } 20 \text{ V}$, $I_O = 0 \text{ mA}$ | | 0.6 | 1 | mA |
| | | $V_I = 4.4 \text{ to } 20 \text{ V}$, $I_O = 250 \text{ mA}$ | | 4 | 6 | |
| | OFF MODE | $V_I = 6 \text{ V}$ | | 50 | 100 | μA |
| SVR | Supply voltage rejection | $I_O = 5 \text{ mA}$ $V_I = 5.4 \pm 1 \text{ V}$ | $f = 120 \text{ Hz}$ | | 73 | dB |
| | | | $f = 1 \text{ KHz}$ | | 70 | |
| | | | $f = 10 \text{ KHz}$ | | 55 | |
| eN | Output noise voltage | $B = 10 \text{ Hz to } 100 \text{ KHz}$ | | 50 | | μV |
| V_d | Dropout voltage ⁽¹⁾ | $I_O = 250 \text{ mA}$ | | 0.4 | 0.6 | V |
| | | $I_O = 250 \text{ mA}$, $T_A = -40 \text{ to } 125^\circ\text{C}$ | | | 0.8 | V |
| V_{IL} | Control input logic low | $T_A = -40 \text{ to } 125^\circ\text{C}$ | | | 0.8 | V |
| V_{IH} | Control Input Logic High | $T_A = -40 \text{ to } 125^\circ\text{C}$ | 2 | | | V |
| I_I | Control input current | $V_I = 6 \text{ V}$, $V_C = 6 \text{ V}$ | | 10 | | μA |
| C_O | Output bypass capacitance | $\text{ESR} = 0.1 \text{ to } 10 \Omega$, $I_O = 0 \text{ to } 250 \text{ mA}$ | 2 | 10 | | μF |

1. For SO-8 package the maximum limit of load regulation and dropout is increased by 20 mV.

Table 14. Electrical characteristics of L4931Cxx35 (refer to the test circuits, $T_J = 25^\circ\text{C}$, $C_I = 0.1 \mu\text{F}$, $C_O = 2.2 \mu\text{F}$ unless otherwise specified).

| Symbol | Parameter | Test conditions | Min. | Typ. | Max. | Unit |
|------------------|--------------------------------|---|----------------------|------|------|---------------|
| V_O | Output voltage | $I_O = 5 \text{ mA}$, $V_I = 5.5 \text{ V}$ | 3.43 | 3.5 | 3.57 | V |
| | | $I_O = 5 \text{ mA}$, $V_I = 5.5 \text{ V}$, $T_A = -25 \text{ to } 85^\circ\text{C}$ | 3.36 | | 3.64 | |
| V_I | Operating input voltage | $I_O = 250 \text{ mA}$ | | | 20 | V |
| I_{out} | Output current limit | | | 300 | | mA |
| ΔV_O | Line regulation | $V_I = 4.3 \text{ to } 20 \text{ V}$, $I_O = 0.5 \text{ mA}$ | | 3 | 18 | mV |
| ΔV_O | Load regulation ⁽¹⁾ | $V_I = 4.5 \text{ V}$, $I_O = 0.5 \text{ to } 250 \text{ mA}$ | | 3 | 18 | mV |
| I_d | Quiescent current ON MODE | $V_I = 4.5 \text{ to } 20 \text{ V}$, $I_O = 0 \text{ mA}$ | | 0.6 | 1 | mA |
| | | $V_I = 4.5 \text{ to } 20 \text{ V}$, $I_O = 250 \text{ mA}$ | | 4 | 6 | |
| | OFF MODE | $V_I = 6 \text{ V}$ | | 50 | 100 | μA |
| SVR | Supply voltage rejection | $I_O = 5 \text{ mA}$ $V_I = 5.5 \pm 1 \text{ V}$ | $f = 120 \text{ Hz}$ | | 73 | dB |
| | | | $f = 1 \text{ KHz}$ | | 70 | |
| | | | $f = 10 \text{ KHz}$ | | 55 | |
| eN | Output noise voltage | $B = 10 \text{ Hz to } 100 \text{ KHz}$ | | 50 | | μV |
| V_d | Dropout voltage ⁽¹⁾ | $I_O = 250 \text{ mA}$ | | 0.4 | 0.6 | V |
| | | $I_O = 250 \text{ mA}$, $T_A = -40 \text{ to } 125^\circ\text{C}$ | | | 0.8 | V |
| V_{IL} | Control input logic low | $T_A = -40 \text{ to } 125^\circ\text{C}$ | | | 0.8 | V |
| V_{IH} | Control Input Logic High | $T_A = -40 \text{ to } 125^\circ\text{C}$ | 2 | | | V |
| I_I | Control input current | $V_I = 6 \text{ V}$, $V_C = 6 \text{ V}$ | | 10 | | μA |
| C_O | Output bypass capacitance | $\text{ESR} = 0.1 \text{ to } 10 \Omega$, $I_O = 0 \text{ to } 250 \text{ mA}$ | 2 | 10 | | μF |

1. For SO-8 package the maximum limit of load regulation and dropout is increased by 20 mV.

Table 15. Electrical characteristics of L4931ABxx40 (refer to the test circuits, $T_J = 25^\circ\text{C}$, $C_I = 0.1 \mu\text{F}$, $C_O = 2.2 \mu\text{F}$ unless otherwise specified).

| Symbol | Parameter | Test conditions | Min. | Typ. | Max. | Unit |
|--------------|--------------------------------|---|----------------------|------|------|---------------|
| V_O | Output voltage | $I_O = 5 \text{ mA}$, $V_I = 6 \text{ V}$ | 3.96 | 4 | 4.04 | V |
| | | $I_O = 5 \text{ mA}$, $V_I = 6 \text{ V}$, $T_A = -25 \text{ to } 85^\circ\text{C}$ | 3.92 | | 4.08 | |
| V_I | Operating input voltage | $I_O = 250 \text{ mA}$ | | | 20 | V |
| I_{out} | Output current limit | | | 300 | | mA |
| ΔV_O | Line regulation | $V_I = 4.7 \text{ to } 20 \text{ V}$, $I_O = 0.5 \text{ mA}$ | | 3.5 | 17.5 | mV |
| ΔV_O | Load regulation ⁽¹⁾ | $V_I = 4.9 \text{ V}$, $I_O = 0.5 \text{ to } 250 \text{ mA}$ | | 3 | 15 | mV |
| I_d | Quiescent current ON MODE | $V_I = 4.9 \text{ to } 20 \text{ V}$, $I_O = 0 \text{ mA}$ | | 0.6 | 1 | mA |
| | | $V_I = 4.9 \text{ to } 20 \text{ V}$, $I_O = 250 \text{ mA}$ | | 4 | 6 | |
| | OFF MODE | $V_I = 6 \text{ V}$ | | 50 | 100 | μA |
| SVR | Supply voltage rejection | $I_O = 5 \text{ mA}$ $V_I = 5.9 \pm 1 \text{ V}$ | $f = 120 \text{ Hz}$ | | 72 | dB |
| | | | $f = 1 \text{ KHz}$ | | 69 | |
| | | | $f = 10 \text{ KHz}$ | | 55 | |
| eN | Output noise voltage | $B = 10 \text{ Hz to } 100 \text{ KHz}$ | | 50 | | μV |
| V_d | Dropout voltage ⁽¹⁾ | $I_O = 250 \text{ mA}$ | | 0.4 | 0.6 | V |
| | | $I_O = 250 \text{ mA}$, $T_A = -40 \text{ to } 125^\circ\text{C}$ | | | 0.8 | V |
| V_{IL} | Control input logic low | $T_A = -40 \text{ to } 125^\circ\text{C}$ | | | 0.8 | V |
| V_{IH} | Control Input Logic High | $T_A = -40 \text{ to } 125^\circ\text{C}$ | 2 | | | V |
| I_I | Control input current | $V_I = 6 \text{ V}$, $V_C = 6 \text{ V}$ | | 10 | | μA |
| C_O | Output bypass capacitance | $\text{ESR} = 0.1 \text{ to } 10 \Omega$, $I_O = 0 \text{ to } 250 \text{ mA}$ | 2 | 10 | | μF |

1. For SO-8 package the maximum limit of load regulation and dropout is increased by 20 mV.

Table 16. Electrical characteristics of L4931Cxx40 (refer to the test circuits, $T_J = 25^\circ\text{C}$, $C_I = 0.1 \mu\text{F}$, $C_O = 2.2 \mu\text{F}$ unless otherwise specified).

| Symbol | Parameter | Test conditions | Min. | Typ. | Max. | Unit |
|------------------|--------------------------------|---|----------------------|------|------|---------------|
| V_O | Output voltage | $I_O = 5 \text{ mA}$, $V_I = 6 \text{ V}$ | 3.92 | 4 | 4.08 | V |
| | | $I_O = 5 \text{ mA}$, $V_I = 6 \text{ V}$, $T_A = -25 \text{ to } 85^\circ\text{C}$ | 3.84 | | 4.16 | |
| V_I | Operating input voltage | $I_O = 250 \text{ mA}$ | | | 20 | V |
| I_{out} | Output current limit | | | 300 | | mA |
| ΔV_O | Line regulation | $V_I = 4.8 \text{ to } 20 \text{ V}$, $I_O = 0.5 \text{ mA}$ | | 3.5 | 21 | mV |
| ΔV_O | Load regulation ⁽¹⁾ | $V_I = 5 \text{ V}$, $I_O = 0.5 \text{ to } 250 \text{ mA}$ | | 3 | 18 | mV |
| I_d | Quiescent current ON MODE | $V_I = 5 \text{ to } 20 \text{ V}$, $I_O = 0 \text{ mA}$ | | 0.6 | 1 | mA |
| | | $V_I = 5 \text{ to } 20 \text{ V}$, $I_O = 250 \text{ mA}$ | | 4 | 6 | |
| | OFF MODE | $V_I = 6 \text{ V}$ | | 50 | 100 | μA |
| SVR | Supply voltage rejection | $I_O = 5 \text{ mA}$ $V_I = 6 \pm 1 \text{ V}$ | $f = 120 \text{ Hz}$ | | 72 | dB |
| | | | $f = 1 \text{ KHz}$ | | 69 | |
| | | | $f = 10 \text{ KHz}$ | | 55 | |
| eN | Output noise voltage | B = 10 Hz to 100 KHz | | 50 | | μV |
| V_d | Dropout voltage ⁽¹⁾ | $I_O = 250 \text{ mA}$ | | 0.4 | 0.6 | V |
| | | $I_O = 250 \text{ mA}$, $T_A = -40 \text{ to } 125^\circ\text{C}$ | | | 0.8 | V |
| V_{IL} | Control input logic low | $T_A = -40 \text{ to } 125^\circ\text{C}$ | | | 0.8 | V |
| V_{IH} | Control Input Logic High | $T_A = -40 \text{ to } 125^\circ\text{C}$ | 2 | | | V |
| I_I | Control input current | $V_I = 6 \text{ V}$, $V_C = 6 \text{ V}$ | | 10 | | μA |
| C_O | Output bypass capacitance | ESR = 0.1 to 10 Ω , $I_O = 0 \text{ to } 250 \text{ mA}$ | 2 | 10 | | μF |

1. For SO-8 package the maximum limit of load regulation and dropout is increased by 20 mV.

Table 17. Electrical characteristics of L4931ABxx47 (refer to the test circuits, $T_J = 25^\circ\text{C}$, $C_I = 0.1 \mu\text{F}$, $C_O = 2.2 \mu\text{F}$ unless otherwise specified).

| Symbol | Parameter | Test conditions | Min. | Typ. | Max. | Unit |
|--------------|--------------------------------|---|----------------------|------|-------|---------------|
| V_O | Output voltage | $I_O = 5 \text{ mA}$, $V_I = 6.7 \text{ V}$ | 4.653 | 4.7 | 4.747 | V |
| | | $I_O = 5 \text{ mA}$, $V_I = 6.7 \text{ V}$ $T_A = -25 \text{ to } 85^\circ\text{C}$ | 4.606 | | 4.794 | |
| V_I | Operating input voltage | $I_O = 250 \text{ mA}$ | | | 20 | V |
| I_{out} | Output current limit | | | 300 | | mA |
| ΔV_O | Line regulation | $V_I = 5.4 \text{ to } 20 \text{ V}$, $I_O = 0.5 \text{ mA}$ | | 3.5 | 17.5 | mV |
| ΔV_O | Load regulation ⁽¹⁾ | $V_I = 5.6 \text{ V}$, $I_O = 0.5 \text{ to } 250 \text{ mA}$ | | 3 | 15 | mV |
| I_d | Quiescent current ON MODE | $V_I = 5.6 \text{ to } 20 \text{ V}$, $I_O = 0 \text{ mA}$ | | 0.6 | 1 | mA |
| | | $V_I = 5.6 \text{ to } 20 \text{ V}$, $I_O = 250 \text{ mA}$ | | 4 | 6 | |
| | OFF MODE | $V_I = 6 \text{ V}$ | | 50 | 100 | μA |
| SVR | Supply voltage rejection | $I_O = 5 \text{ mA}$ $V_I = 6.6 \pm 1 \text{ V}$ | $f = 120 \text{ Hz}$ | | 71 | dB |
| | | | $f = 1 \text{ KHz}$ | | 68 | |
| | | | $f = 10 \text{ KHz}$ | | 55 | |
| eN | Output noise voltage | $B = 10 \text{ Hz to } 100 \text{ KHz}$ | | 50 | | μV |
| V_d | Dropout voltage ⁽¹⁾ | $I_O = 250 \text{ mA}$ | | 0.4 | 0.6 | V |
| | | $I_O = 250 \text{ mA}$, $T_A = -40 \text{ to } 125^\circ\text{C}$ | | | 0.8 | V |
| V_{IL} | Control input logic low | $T_A = -40 \text{ to } 125^\circ\text{C}$ | | | 0.8 | V |
| V_{IH} | Control Input Logic High | $T_A = -40 \text{ to } 125^\circ\text{C}$ | 2 | | | V |
| I_I | Control input current | $V_I = 6 \text{ V}$, $V_C = 6 \text{ V}$ | | 10 | | μA |
| C_O | Output bypass capacitance | $\text{ESR} = 0.1 \text{ to } 10 \Omega$, $I_O = 0 \text{ to } 250 \text{ mA}$ | 2 | 10 | | μF |

1. For SO-8 package the maximum limit of load regulation and dropout is increased by 20 mV.

Table 18. Electrical characteristics of L4931Cxx47 (refer to the test circuits, $T_J = 25^\circ\text{C}$, $C_I = 0.1 \mu\text{F}$, $C_O = 2.2 \mu\text{F}$ unless otherwise specified).

| Symbol | Parameter | Test conditions | Min. | Typ. | Max. | Unit |
|------------------|--------------------------------|---|----------------------|------|-------|---------------|
| V_O | Output voltage | $I_O = 5 \text{ mA}$, $V_I = 6.7 \text{ V}$ | 4.606 | 4.7 | 4.794 | V |
| | | $I_O = 5 \text{ mA}$, $V_I = 6.7 \text{ V}$, $T_A = -25 \text{ to } 85^\circ\text{C}$ | 4.512 | | 4.888 | |
| V_I | Operating input voltage | $I_O = 250 \text{ mA}$ | | | 20 | V |
| I_{out} | Output current limit | | | 300 | | mA |
| ΔV_O | Line regulation | $V_I = 5.5 \text{ to } 20 \text{ V}$, $I_O = 0.5 \text{ mA}$ | | 3.5 | 21 | mV |
| ΔV_O | Load regulation ⁽¹⁾ | $V_I = 5.7 \text{ V}$, $I_O = 0.5 \text{ to } 250 \text{ mA}$ | | 3 | 18 | mV |
| I_d | Quiescent current ON MODE | $V_I = 5.7 \text{ to } 20 \text{ V}$, $I_O = 0 \text{ mA}$ | | 0.6 | 1 | mA |
| | | $V_I = 5.7 \text{ to } 20 \text{ V}$, $I_O = 250 \text{ mA}$ | | 4 | 6 | |
| | OFF MODE | $V_I = 6 \text{ V}$ | | 50 | 100 | μA |
| SVR | Supply voltage rejection | $I_O = 5 \text{ mA}$ $V_I = 6.7 \pm 1 \text{ V}$ | $f = 120 \text{ Hz}$ | | 71 | dB |
| | | | $f = 1 \text{ KHz}$ | | 68 | |
| | | | $f = 10 \text{ KHz}$ | | 55 | |
| eN | Output noise voltage | $B = 10 \text{ Hz to } 100 \text{ KHz}$ | | 50 | | μV |
| V_d | Dropout voltage ⁽¹⁾ | $I_O = 250 \text{ mA}$ | | 0.4 | 0.6 | V |
| | | $I_O = 250 \text{ mA}$, $T_A = -40 \text{ to } 125^\circ\text{C}$ | | | 0.8 | V |
| V_{IL} | Control input logic low | $T_A = -40 \text{ to } 125^\circ\text{C}$ | | | 0.8 | V |
| V_{IH} | Control Input Logic High | $T_A = -40 \text{ to } 125^\circ\text{C}$ | 2 | | | V |
| I_I | Control input current | $V_I = 6 \text{ V}$, $V_C = 6 \text{ V}$ | | 10 | | μA |
| C_O | Output bypass capacitance | $\text{ESR} = 0.1 \text{ to } 10 \Omega$, $I_O = 0 \text{ to } 250 \text{ mA}$ | 2 | 10 | | μF |

1. For SO-8 package the maximum limit of load regulation and dropout is increased by 20 mV.

Table 19. Electrical characteristics of L4931ABxx50 (refer to the test circuits, $T_J = 25^\circ\text{C}$, $C_I = 0.1 \mu\text{F}$, $C_O = 2.2 \mu\text{F}$ unless otherwise specified).

| Symbol | Parameter | Test conditions | Min. | Typ. | Max. | Unit |
|--------------|--------------------------------|---|----------------------|------|------|---------------|
| V_O | Output voltage | $I_O = 5 \text{ mA}$, $V_I = 7 \text{ V}$ | 4.95 | 5 | 5.05 | V |
| | | $I_O = 5 \text{ mA}$, $V_I = 7 \text{ V}$, $T_A = -25 \text{ to } 85^\circ\text{C}$ | 4.9 | | 5.1 | |
| V_I | Operating input voltage | $I_O = 250 \text{ mA}$ | | | 20 | V |
| I_{out} | Output current limit | | | 300 | | mA |
| ΔV_O | Line regulation | $V_I = 5.8 \text{ to } 20 \text{ V}$, $I_O = 0.5 \text{ mA}$ | | 3.5 | 17.5 | mV |
| ΔV_O | Load regulation ⁽¹⁾ | $V_I = 6 \text{ V}$, $I_O = 0.5 \text{ to } 250 \text{ mA}$ | | 3 | 15 | mV |
| I_d | Quiescent current ON MODE | $V_I = 6 \text{ to } 20 \text{ V}$, $I_O = 0 \text{ mA}$ | | 0.6 | 1 | mA |
| | | $V_I = 6 \text{ to } 20 \text{ V}$, $I_O = 250 \text{ mA}$ | | 4 | 6 | |
| | OFF MODE | $V_I = 6 \text{ V}$ | | 50 | 100 | μA |
| SVR | Supply voltage rejection | $I_O = 5 \text{ mA}$ $V_I = 7 \pm 1 \text{ V}$ | $f = 120 \text{ Hz}$ | | 70 | dB |
| | | | $f = 1 \text{ KHz}$ | | 67 | |
| | | | $f = 10 \text{ KHz}$ | | 55 | |
| eN | Output noise voltage | B = 10 Hz to 100 KHz | | 50 | | μV |
| V_d | Dropout voltage ⁽¹⁾ | $I_O = 250 \text{ mA}$ | | 0.4 | 0.6 | V |
| | | $I_O = 250 \text{ mA}$, $T_A = -40 \text{ to } 125^\circ\text{C}$ | | | 0.8 | V |
| V_{IL} | Control input logic low | $T_A = -40 \text{ to } 125^\circ\text{C}$ | | | 0.8 | V |
| V_{IH} | Control Input Logic High | $T_A = -40 \text{ to } 125^\circ\text{C}$ | 2 | | | V |
| I_I | Control input current | $V_I = 6 \text{ V}$, $V_C = 6 \text{ V}$ | | 10 | | μA |
| C_O | Output bypass capacitance | ESR = 0.1 to 10 Ω , $I_O = 0 \text{ to } 250 \text{ mA}$ | 2 | 10 | | μF |

1. For SO-8 package the maximum limit of load regulation and dropout is increased by 20 mV.

Table 20. Electrical characteristics of L4931Cxx50 (refer to the test circuits, $T_J = 25^\circ\text{C}$, $C_I = 0.1 \mu\text{F}$, $C_O = 2.2 \mu\text{F}$ unless otherwise specified).

| Symbol | Parameter | Test conditions | Min. | Typ. | Max. | Unit |
|------------------|--------------------------------|---|----------------------|------|------|---------------|
| V_O | Output voltage | $I_O = 5 \text{ mA}$, $V_I = 7 \text{ V}$ | 4.9 | 5 | 5.1 | V |
| | | $I_O = 5 \text{ mA}$, $V_I = 7 \text{ V}$, $T_A = -25 \text{ to } 85^\circ\text{C}$ | 4.8 | | 5.2 | |
| V_I | Operating input voltage | $I_O = 250 \text{ mA}$ | | | 20 | V |
| I_{out} | Output current limit | | | 300 | | mA |
| ΔV_O | Line regulation | $V_I = 5.8 \text{ to } 20 \text{ V}$, $I_O = 0.5 \text{ mA}$ | | 3.5 | 17.5 | mV |
| ΔV_O | Load regulation ⁽¹⁾ | $V_I = 6 \text{ V}$, $I_O = 0.5 \text{ to } 250 \text{ mA}$ | | 3 | 15 | mV |
| I_d | Quiescent current ON MODE | $V_I = 6 \text{ to } 20 \text{ V}$, $I_O = 0 \text{ mA}$ | | 0.6 | 1 | mA |
| | | $V_I = 6 \text{ to } 20 \text{ V}$, $I_O = 250 \text{ mA}$ | | 4 | 6 | |
| | OFF MODE | $V_I = 6 \text{ V}$ | | 50 | 100 | μA |
| SVR | Supply voltage rejection | $I_O = 5 \text{ mA}$ $V_I = 7 \pm 1 \text{ V}$ | $f = 120 \text{ Hz}$ | | 70 | dB |
| | | | $f = 1 \text{ KHz}$ | | 67 | |
| | | | $f = 10 \text{ KHz}$ | | 55 | |
| eN | Output noise voltage | $B = 10 \text{ Hz to } 100 \text{ KHz}$ | | 50 | | μV |
| V_d | Dropout voltage ⁽¹⁾ | $I_O = 250 \text{ mA}$ | | 0.4 | 0.6 | V |
| | | $I_O = 250 \text{ mA}$, $T_A = -40 \text{ to } 125^\circ\text{C}$ | | | 0.8 | V |
| V_{IL} | Control input logic low | $T_A = -40 \text{ to } 125^\circ\text{C}$ | | | 0.8 | V |
| V_{IH} | Control Input Logic High | $T_A = -40 \text{ to } 125^\circ\text{C}$ | 2 | | | V |
| I_I | Control input current | $V_I = 6 \text{ V}$, $V_C = 6 \text{ V}$ | | 10 | | μA |
| C_O | Output bypass capacitance | $\text{ESR} = 0.1 \text{ to } 10 \Omega$, $I_O = 0 \text{ to } 250 \text{ mA}$ | 2 | 10 | | μF |

1. For SO-8 package the maximum limit of load regulation and dropout is increased by 20 mV.

Table 21. Electrical characteristics of L4931ABxx80 (refer to the test circuits, $T_J = 25^\circ\text{C}$, $C_I = 0.1 \mu\text{F}$, $C_O = 2.2 \mu\text{F}$ unless otherwise specified).

| Symbol | Parameter | Test conditions | Min. | Typ. | Max. | Unit |
|------------------|--------------------------------|--|----------------------|------|------|---------------|
| V_O | Output voltage | $I_O = 5 \text{ mA}$, $V_I = 10 \text{ V}$ | 7.92 | 8 | 8.08 | V |
| | | $I_O = 5 \text{ mA}$, $V_I = 10 \text{ V}$, $T_A = -25 \text{ to } 85^\circ\text{C}$ | 7.84 | | 8.16 | |
| V_I | Operating input voltage | $I_O = 250 \text{ mA}$ | | | 20 | V |
| I_{out} | Output current limit | | | 300 | | mA |
| ΔV_O | Line regulation | $V_I = 8.8 \text{ to } 20 \text{ V}$, $I_O = 0.5 \text{ mA}$ | | 4 | 20 | mV |
| ΔV_O | Load regulation ⁽¹⁾ | $V_I = 9 \text{ V}$, $I_O = 0.5 \text{ to } 250 \text{ mA}$ | | 3 | 15 | mV |
| I_d | Quiescent current ON MODE | $V_I = 9 \text{ to } 20 \text{ V}$, $I_O = 0 \text{ mA}$ | | 0.8 | 1.6 | mA |
| | | $V_I = 9 \text{ to } 20 \text{ V}$, $I_O = 250 \text{ mA}$ | | 4.5 | 7 | |
| | OFF MODE | $V_I = 6 \text{ V}$ | | 70 | 140 | μA |
| SVR | Supply voltage rejection | $I_O = 5 \text{ mA}$ $V_I = 10 \pm 1 \text{ V}$ | $f = 120 \text{ Hz}$ | | 67 | dB |
| | | | $f = 1 \text{ KHz}$ | | 64 | |
| | | | $f = 10 \text{ KHz}$ | | 55 | |
| eN | Output noise voltage | B = 10 Hz to 100 KHz | | 50 | | μV |
| V_d | Dropout voltage ⁽¹⁾ | $I_O = 250 \text{ mA}$ | | 0.4 | 0.6 | V |
| | | $I_O = 250 \text{ mA}$, $T_A = -40 \text{ to } 125^\circ\text{C}$ | | | 0.8 | V |
| V_{IL} | Control input logic low | $T_A = -40 \text{ to } 125^\circ\text{C}$ | | | 0.8 | V |
| V_{IH} | Control Input Logic High | $T_A = -40 \text{ to } 125^\circ\text{C}$ | 2 | | | V |
| I_I | Control input current | $V_I = 6 \text{ V}$, $V_C = 6 \text{ V}$ | | 10 | | μA |
| C_O | Output bypass capacitance | ESR = 0.1 to 10 Ω , $I_O = 0 \text{ to } 250 \text{ mA}$ | 2 | 10 | | μF |

1. For SO-8 package the maximum limit of load regulation and dropout is increased by 20 mV.

Table 22. Electrical characteristics of L4931Cxx80 (refer to the test circuits, $T_J = 25^\circ\text{C}$, $C_I = 0.1 \mu\text{F}$, $C_O = 2.2 \mu\text{F}$ unless otherwise specified).

| Symbol | Parameter | Test conditions | Min. | Typ. | Max. | Unit |
|------------------|--------------------------------|--|----------------------|------|------|---------------|
| V_O | Output voltage | $I_O = 5 \text{ mA}$, $V_I = 10 \text{ V}$ | 7.84 | 8 | 8.16 | V |
| | | $I_O = 5 \text{ mA}$, $V_I = 10 \text{ V}$, $T_A = -25 \text{ to } 85^\circ\text{C}$ | 7.68 | | 8.32 | |
| V_I | Operating input voltage | $I_O = 250 \text{ mA}$ | | | 20 | V |
| I_{out} | Output current limit | | | 300 | | mA |
| ΔV_O | Line regulation | $V_I = 8.9 \text{ to } 20 \text{ V}$, $I_O = 0.5 \text{ mA}$ | | 4 | 24 | mV |
| ΔV_O | Load regulation ⁽¹⁾ | $V_I = 9.1 \text{ V}$, $I_O = 0.5 \text{ to } 250 \text{ mA}$ | | 3 | 18 | mV |
| I_d | Quiescent current ON MODE | $V_I = 9.1 \text{ to } 20 \text{ V}$, $I_O = 0 \text{ mA}$ | | 0.8 | 1.6 | mA |
| | | $V_I = 9.1 \text{ to } 20 \text{ V}$, $I_O = 250 \text{ mA}$ | | 4.5 | 7 | |
| | OFF MODE | $V_I = 6 \text{ V}$ | | 70 | 140 | μA |
| SVR | Supply voltage rejection | $I_O = 5 \text{ mA}$ $V_I = 10.1 \pm 1 \text{ V}$ | $f = 120 \text{ Hz}$ | | 67 | dB |
| | | | $f = 1 \text{ KHz}$ | | 64 | |
| | | | $f = 10 \text{ KHz}$ | | 55 | |
| eN | Output noise voltage | $B = 10 \text{ Hz to } 100 \text{ KHz}$ | | 50 | | μV |
| V_d | Dropout voltage ⁽¹⁾ | $I_O = 250 \text{ mA}$ | | 0.4 | 0.6 | V |
| | | $I_O = 250 \text{ mA}$, $T_A = -40 \text{ to } 125^\circ\text{C}$ | | | 0.8 | V |
| V_{IL} | Control input logic low | $T_A = -40 \text{ to } 125^\circ\text{C}$ | | | 0.8 | V |
| V_{IH} | Control Input Logic High | $T_A = -40 \text{ to } 125^\circ\text{C}$ | 2 | | | V |
| I_I | Control input current | $V_I = 6 \text{ V}$, $V_C = 6 \text{ V}$ | | 10 | | μA |
| C_O | Output bypass capacitance | $\text{ESR} = 0.1 \text{ to } 10 \Omega$, $I_O = 0 \text{ to } 250 \text{ mA}$ | 2 | 10 | | μF |

1. For SO-8 package the maximum limit of load regulation and dropout is increased by 20 mV.

Table 23. Electrical characteristics of L4931ABxx120 (refer to the test circuits, $T_J = 25^\circ\text{C}$, $C_I = 0.1 \mu\text{F}$, $C_O = 2.2 \mu\text{F}$ unless otherwise specified).

| Symbol | Parameter | Test conditions | Min. | Typ. | Max. | Unit |
|------------------|--------------------------------|--|----------------------|------|-------|---------------|
| V_O | Output voltage | $I_O = 5 \text{ mA}$, $V_I = 14 \text{ V}$ | 11.88 | 12 | 12.12 | V |
| | | $I_O = 5 \text{ mA}$, $V_I = 14 \text{ V}$, $T_A = -25 \text{ to } 85^\circ\text{C}$ | 11.76 | | 12.24 | |
| V_I | Operating input voltage | $I_O = 250 \text{ mA}$ | | | 20 | V |
| I_{out} | Output current limit | | | 300 | | mA |
| ΔV_O | Line regulation | $V_I = 12.8 \text{ to } 20 \text{ V}$, $I_O = 0.5 \text{ mA}$ | | 4 | 20 | mV |
| ΔV_O | Load regulation ⁽¹⁾ | $V_I = 13 \text{ V}$, $I_O = 0.5 \text{ to } 250 \text{ mA}$ | | 3 | 15 | mV |
| I_d | Quiescent current ON MODE | $V_I = 13 \text{ to } 20 \text{ V}$, $I_O = 0 \text{ mA}$ | | 0.8 | 1.6 | mA |
| | | $V_I = 13 \text{ to } 20 \text{ V}$, $I_O = 250 \text{ mA}$ | | 4.5 | 7 | |
| | OFF MODE | $V_I = 6 \text{ V}$ | | 90 | 180 | μA |
| SVR | Supply voltage rejection | $I_O = 5 \text{ mA}$ $V_I = 14 \pm 1 \text{ V}$ | $f = 120 \text{ Hz}$ | | 64 | dB |
| | | | $f = 1 \text{ KHz}$ | | 61 | |
| | | | $f = 10 \text{ KHz}$ | | 55 | |
| eN | Output noise voltage | B = 10 Hz to 100 KHz | | 50 | | μV |
| V_d | Dropout voltage ⁽¹⁾ | $I_O = 250 \text{ mA}$ | | 0.4 | 0.6 | V |
| | | $I_O = 250 \text{ mA}$, $T_A = -40 \text{ to } 125^\circ\text{C}$ | | | 0.8 | V |
| V_{IL} | Control input logic low | $T_A = -40 \text{ to } 125^\circ\text{C}$ | | | 0.8 | V |
| V_{IH} | Control Input Logic High | $T_A = -40 \text{ to } 125^\circ\text{C}$ | 2 | | | V |
| I_I | Control input current | $V_I = 6 \text{ V}$, $V_C = 6 \text{ V}$ | | 10 | | μA |
| C_O | Output bypass capacitance | ESR = 0.1 to 10 Ω , $I_O = 0 \text{ to } 250 \text{ mA}$ | 2 | 10 | | μF |

1. For SO-8 package the maximum limit of load regulation and dropout is increased by 20 mV.

Table 24. Electrical characteristics of L4931Cxx120 (refer to the test circuits, $T_J = 25^\circ\text{C}$, $C_I = 0.1 \mu\text{F}$, $C_O = 2.2 \mu\text{F}$ unless otherwise specified).

| Symbol | Parameter | Test conditions | Min. | Typ. | Max. | Unit |
|------------------|--------------------------------|--|----------------------|------|-------|---------------|
| V_O | Output voltage | $I_O = 5 \text{ mA}$, $V_I = 14 \text{ V}$ | 11.76 | 12 | 12.24 | V |
| | | $I_O = 5 \text{ mA}$, $V_I = 14 \text{ V}$, $T_A = -25 \text{ to } 85^\circ\text{C}$ | 11.52 | | 12.48 | |
| V_I | Operating input voltage | $I_O = 250 \text{ mA}$ | | | 20 | V |
| I_{out} | Output current limit | | | 300 | | mA |
| ΔV_O | Line regulation | $V_I = 12.9 \text{ to } 20 \text{ V}$, $I_O = 0.5 \text{ mA}$ | | 4 | 24 | mV |
| ΔV_O | Load regulation ⁽¹⁾ | $V_I = 13.1 \text{ V}$, $I_O = 0.5 \text{ to } 250 \text{ mA}$ | | 3 | 18 | mV |
| I_d | Quiescent current ON MODE | $V_I = 13.1 \text{ to } 20 \text{ V}$, $I_O = 0 \text{ mA}$ | | 0.8 | 1.6 | mA |
| | | $V_I = 13.1 \text{ to } 20 \text{ V}$, $I_O = 250 \text{ mA}$ | | 4.5 | 7 | |
| | OFF MODE | $V_I = 6 \text{ V}$ | | 90 | 180 | μA |
| SVR | Supply voltage rejection | $I_O = 5 \text{ mA}$ $V_I = 14.1 \pm 1 \text{ V}$ | $f = 120 \text{ Hz}$ | | 64 | dB |
| | | | $f = 1 \text{ KHz}$ | | 61 | |
| | | | $f = 10 \text{ KHz}$ | | 55 | |
| eN | Output noise voltage | $B = 10 \text{ Hz to } 100 \text{ KHz}$ | | 50 | | μV |
| V_d | Dropout voltage ⁽¹⁾ | $I_O = 250 \text{ mA}$ | | 0.4 | 0.6 | V |
| | | $I_O = 250 \text{ mA}$, $T_A = -40 \text{ to } 125^\circ\text{C}$ | | | 0.8 | V |
| V_{IL} | Control input logic low | $T_A = -40 \text{ to } 125^\circ\text{C}$ | | | 0.8 | V |
| V_{IH} | Control Input Logic High | $T_A = -40 \text{ to } 125^\circ\text{C}$ | 2 | | | V |
| I_I | Control input current | $V_I = 6 \text{ V}$, $V_C = 6 \text{ V}$ | | 10 | | μA |
| C_O | Output bypass capacitance | $\text{ESR} = 0.1 \text{ to } 10 \Omega$, $I_O = 0 \text{ to } 250 \text{ mA}$ | 2 | 10 | | μF |

1. For SO-8 package the maximum limit of load regulation and dropout is increased by 20 mV.

5 Typical application

Figure 3. Supply current vs output current

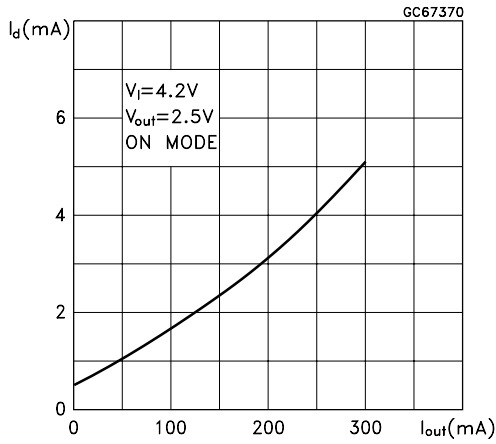

Figure 4. Dropout voltage vs temperature

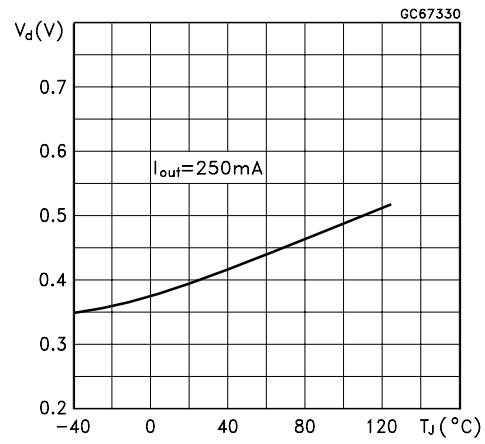

Figure 5. Supply current vs input voltage

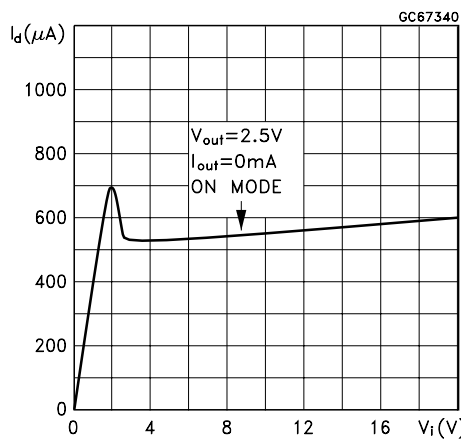

Figure 6. Supply current vs temperature

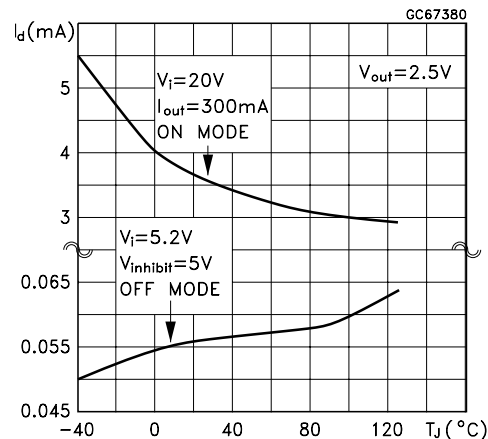

Figure 7. Short circuit current vs dropout voltage

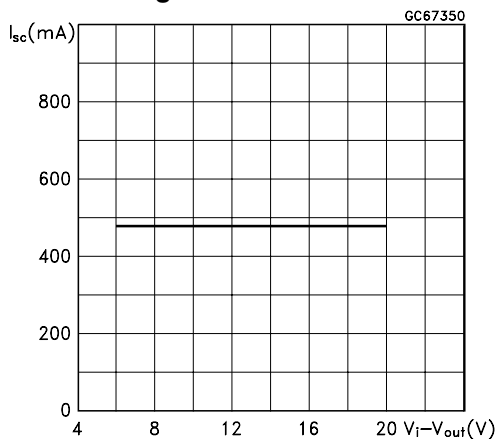
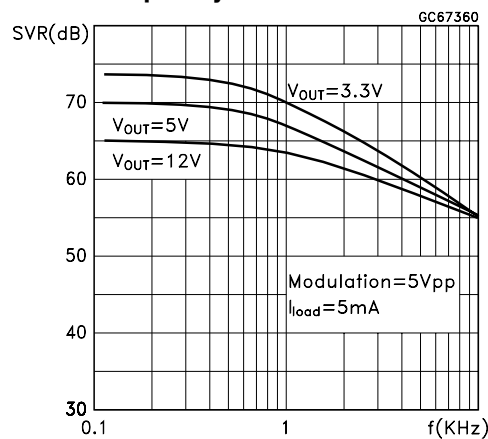

Figure 8. S.V.R. vs Input voltage signal frequency



6 Package mechanical data

In order to meet environmental requirements, ST offers these devices in ECOPACK® packages. These packages have a Lead-free second level interconnect. The category of second Level Interconnect is marked on the package and on the inner box label, in compliance with JEDEC Standard JESD97. The maximum ratings related to soldering conditions are also marked on the inner box label. ECOPACK is an ST trademark. ECOPACK specifications are available at: www.st.com.

TO-220 MECHANICAL DATA

| DIM. | mm. | | | inch | | |
|------|-------|------|-------|-------|-------|-------|
| | MIN. | TYP | MAX. | MIN. | TYP. | MAX. |
| A | 4.40 | | 4.60 | 0.173 | | 0.181 |
| C | 1.23 | | 1.32 | 0.048 | | 0.051 |
| D | 2.40 | | 2.72 | 0.094 | | 0.107 |
| D1 | | 1.27 | | | 0.050 | |
| E | 0.49 | | 0.70 | 0.019 | | 0.027 |
| F | 0.61 | | 0.88 | 0.024 | | 0.034 |
| F1 | 1.14 | | 1.70 | 0.044 | | 0.067 |
| F2 | 1.14 | | 1.70 | 0.044 | | 0.067 |
| G | 4.95 | | 5.15 | 0.194 | | 0.203 |
| G1 | 2.4 | | 2.7 | 0.094 | | 0.106 |
| H2 | 10.0 | | 10.40 | 0.393 | | 0.409 |
| L2 | | 16.4 | | | 0.645 | |
| L4 | 13.0 | | 14.0 | 0.511 | | 0.551 |
| L5 | 2.65 | | 2.95 | 0.104 | | 0.116 |
| L6 | 15.25 | | 15.75 | 0.600 | | 0.620 |
| L7 | 6.2 | | 6.6 | 0.244 | | 0.260 |
| L9 | 3.5 | | 3.93 | 0.137 | | 0.154 |
| DIA. | 3.75 | | 3.85 | 0.147 | | 0.151 |

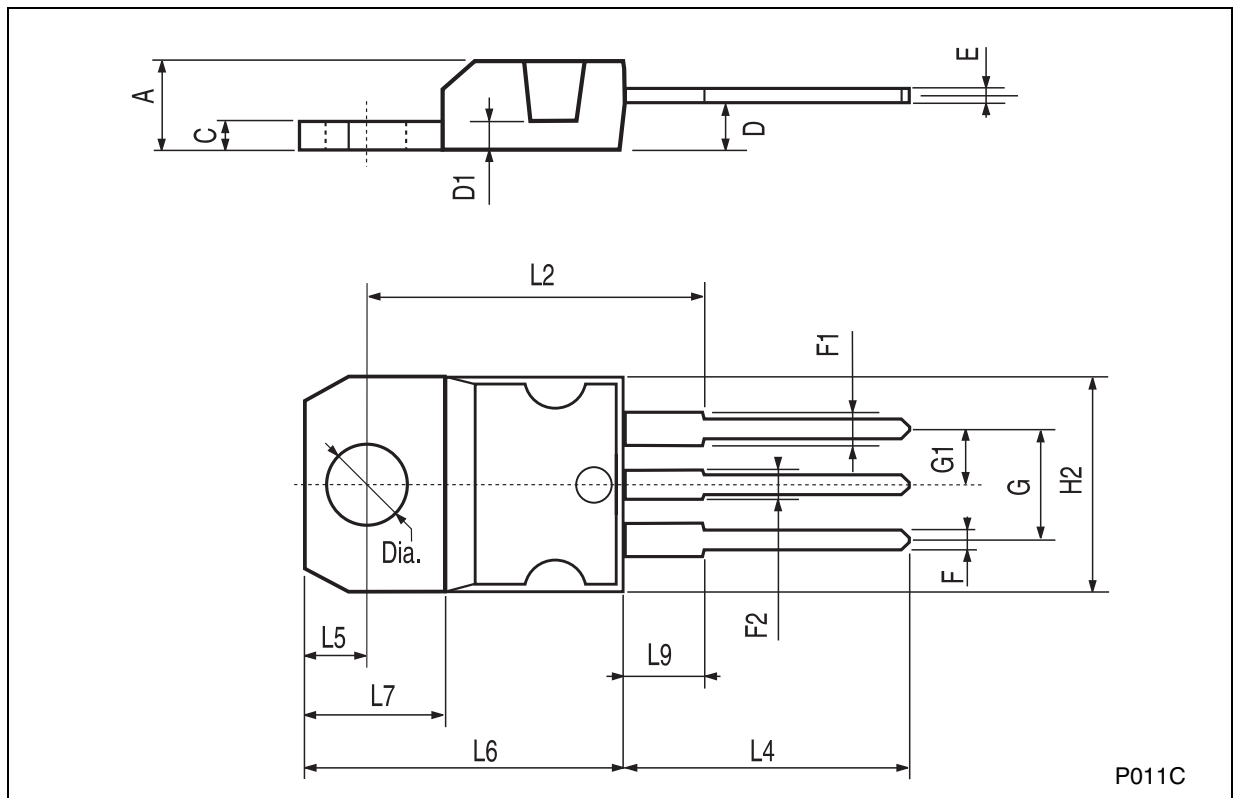

| |
|------------------------------|
| TO-92 MECHANICAL DATA |
|------------------------------|

| DIM. | mm. | | | mils | | |
|----------|------|-----|-------|-------|------|-------|
| | MIN. | TYP | MAX. | MIN. | TYP. | MAX. |
| A | 4.32 | | 4.95 | 170.1 | | 194.9 |
| b | 0.36 | | 0.51 | 14.2 | | 20.1 |
| D | 4.45 | | 4.95 | 175.2 | | 194.9 |
| E | 3.30 | | 3.94 | 129.9 | | 155.1 |
| e | 2.41 | | 2.67 | 94.9 | | 105.1 |
| e1 | 1.14 | | 1.40 | 44.9 | | 55.1 |
| L | 12.7 | | 15.49 | 500.0 | | 609.8 |
| R | 2.16 | | 2.41 | 85.0 | | 94.9 |
| S1 | 0.92 | | 1.52 | 36.2 | | 59.8 |
| W | 0.41 | | 0.56 | 16.1 | | 22.0 |
| α | | 5° | | | 5° | |

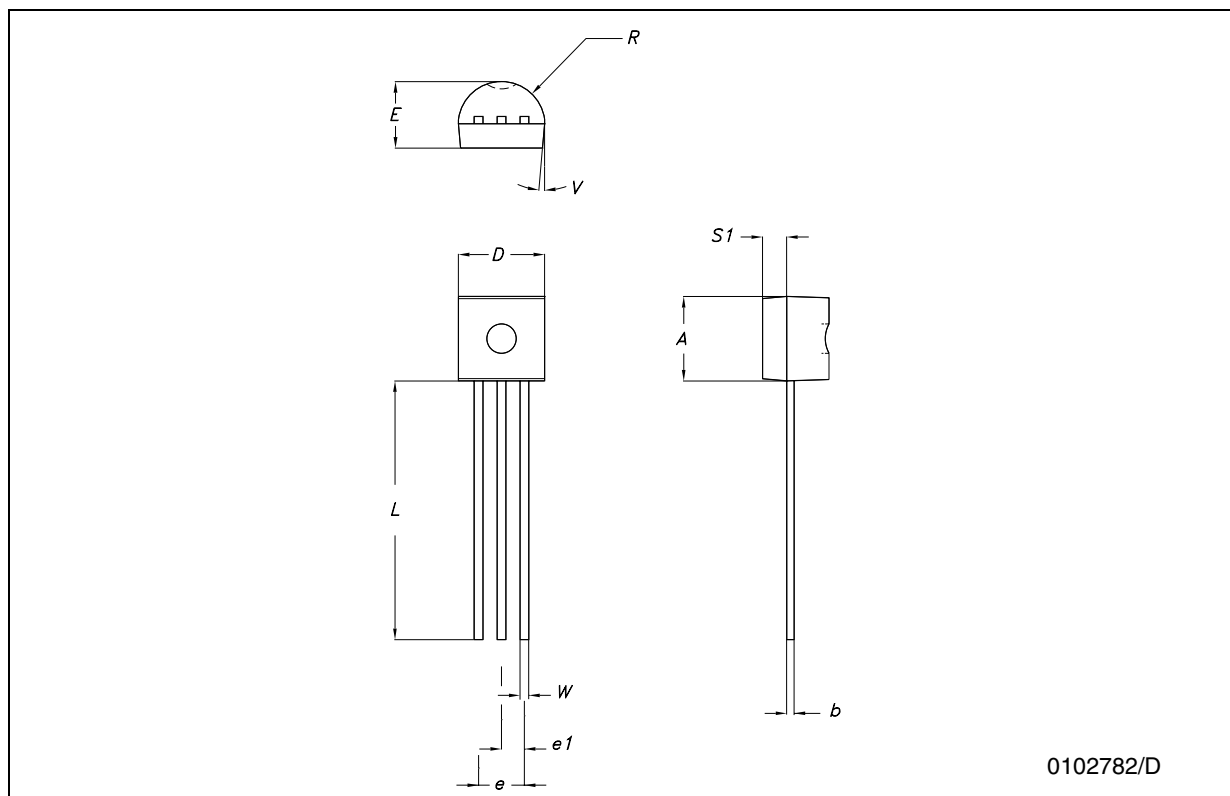

PPAK MECHANICAL DATA

| DIM. | mm. | | | inch | | |
|------|------|------|------|-------|-------|-------|
| | MIN. | TYP | MAX. | MIN. | TYP. | MAX. |
| A | 2.2 | | 2.4 | 0.086 | | 0.094 |
| A1 | 0.9 | | 1.1 | 0.035 | | 0.043 |
| A2 | 0.03 | | 0.23 | 0.001 | | 0.009 |
| B | 0.4 | | 0.6 | 0.015 | | 0.023 |
| B2 | 5.2 | | 5.4 | 0.204 | | 0.212 |
| C | 0.45 | | 0.6 | 0.017 | | 0.023 |
| C2 | 0.48 | | 0.6 | 0.019 | | 0.023 |
| D | 6 | | 6.2 | 0.236 | | 0.244 |
| D1 | | 5.1 | | | 0.201 | |
| E | 6.4 | | 6.6 | 0.252 | | 0.260 |
| E1 | | 4.7 | | | 0.185 | |
| e | | 1.27 | | | 0.050 | |
| G | 4.9 | | 5.25 | 0.193 | | 0.206 |
| G1 | 2.38 | | 2.7 | 0.093 | | 0.106 |
| H | 9.35 | | 10.1 | 0.368 | | 0.397 |
| L2 | | 0.8 | 1 | | 0.031 | 0.039 |
| L4 | 0.6 | | 1 | 0.023 | | 0.039 |
| L5 | 1 | | | 0.039 | | |
| L6 | | 2.8 | | | 0.110 | |

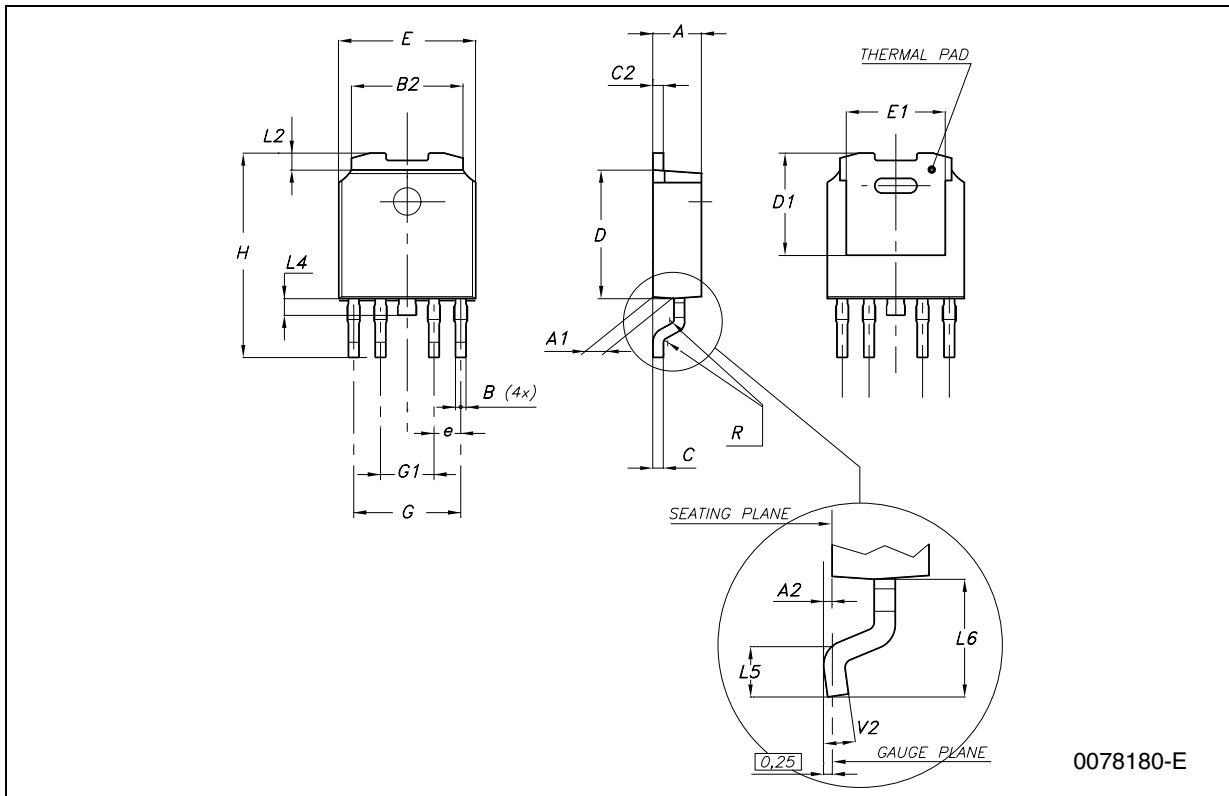

0078180-E

DPAK MECHANICAL DATA

| DIM. | mm. | | | inch | | |
|------|------|------|------|-------|-------|-------|
| | MIN. | TYP | MAX. | MIN. | TYP. | MAX. |
| A | 2.2 | | 2.4 | 0.086 | | 0.094 |
| A1 | 0.9 | | 1.1 | 0.035 | | 0.043 |
| A2 | 0.03 | | 0.23 | 0.001 | | 0.009 |
| B | 0.64 | | 0.9 | 0.025 | | 0.035 |
| b4 | 5.2 | | 5.4 | 0.204 | | 0.212 |
| C | 0.45 | | 0.6 | 0.017 | | 0.023 |
| C2 | 0.48 | | 0.6 | 0.019 | | 0.023 |
| D | 6 | | 6.2 | 0.236 | | 0.244 |
| D1 | | 5.1 | | | 0.200 | |
| E | 6.4 | | 6.6 | 0.252 | | 0.260 |
| E1 | | 4.7 | | | 0.185 | |
| e | | 2.28 | | | 0.090 | |
| e1 | 4.4 | | 4.6 | 0.173 | | 0.181 |
| H | 9.35 | | 10.1 | 0.368 | | 0.397 |
| L | 1 | | | 0.039 | | |
| (L1) | | 2.8 | | | 0.110 | |
| L2 | | 0.8 | | | 0.031 | |
| L4 | 0.6 | | 1 | 0.023 | | 0.039 |
| R | | 0.2 | | | 0.008 | |
| V2 | 0° | | 8° | 0° | | 8° |

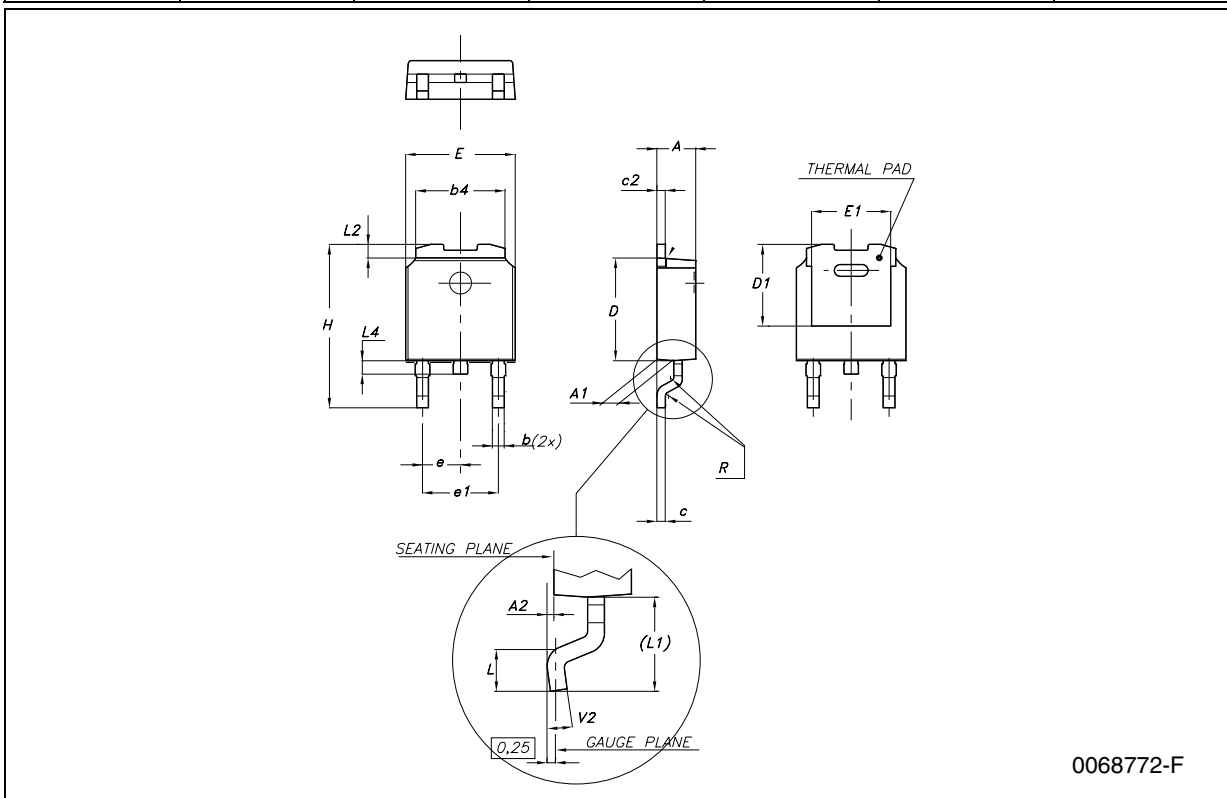

0068772-F

SO-8 MECHANICAL DATA

| DIM. | mm. | | | inch | | |
|------|-----------|------|------|-------|-------|-------|
| | MIN. | TYP | MAX. | MIN. | TYP. | MAX. |
| A | 1.35 | | 1.75 | 0.053 | | 0.069 |
| A1 | 0.10 | | 0.25 | 0.04 | | 0.010 |
| A2 | 1.10 | | 1.65 | 0.043 | | 0.065 |
| B | 0.33 | | 0.51 | 0.013 | | 0.020 |
| C | 0.19 | | 0.25 | 0.007 | | 0.010 |
| D | 4.80 | | 5.00 | 0.189 | | 0.197 |
| E | 3.80 | | 4.00 | 0.150 | | 0.157 |
| e | | 1.27 | | | 0.050 | |
| H | 5.80 | | 6.20 | 0.228 | | 0.244 |
| h | 0.25 | | 0.50 | 0.010 | | 0.020 |
| L | 0.40 | | 1.27 | 0.016 | | 0.050 |
| k | 8° (max.) | | | | | |
| ddd | | | 0.1 | | | 0.04 |

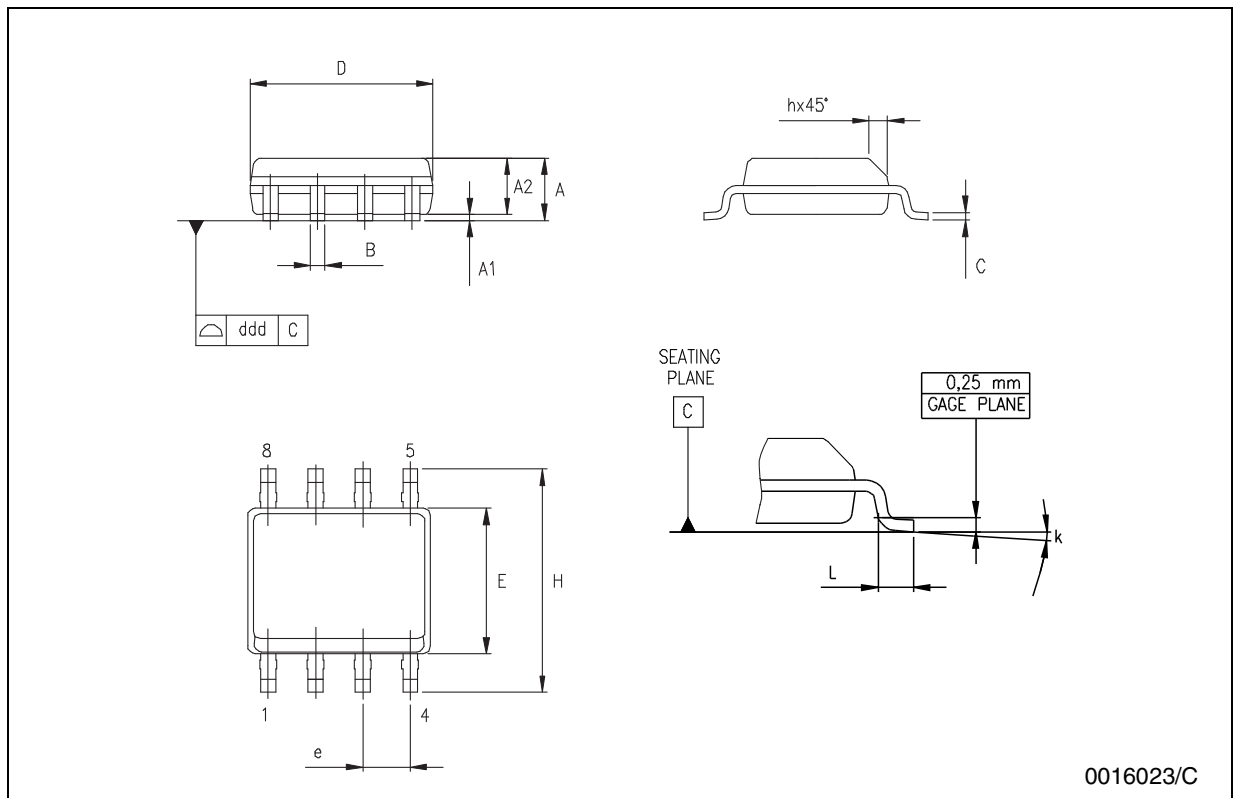

0016023/C

Tape & Reel DPAK-PPAK MECHANICAL DATA

| DIM. | mm. | | | inch | | |
|------|-------|-------|-------|-------|-------|--------|
| | MIN. | TYP | MAX. | MIN. | TYP. | MAX. |
| A | | | 330 | | | 12.992 |
| C | 12.8 | 13.0 | 13.2 | 0.504 | 0.512 | 0.519 |
| D | 20.2 | | | 0.795 | | |
| N | 60 | | | 2.362 | | |
| T | | | 22.4 | | | 0.882 |
| Ao | 6.80 | 6.90 | 7.00 | 0.268 | 0.272 | 0.276 |
| Bo | 10.40 | 10.50 | 10.60 | 0.409 | 0.413 | 0.417 |
| Ko | 2.55 | 2.65 | 2.75 | 0.100 | 0.104 | 0.105 |
| Po | 3.9 | 4.0 | 4.1 | 0.153 | 0.157 | 0.161 |
| P | 7.9 | 8.0 | 8.1 | 0.311 | 0.315 | 0.319 |

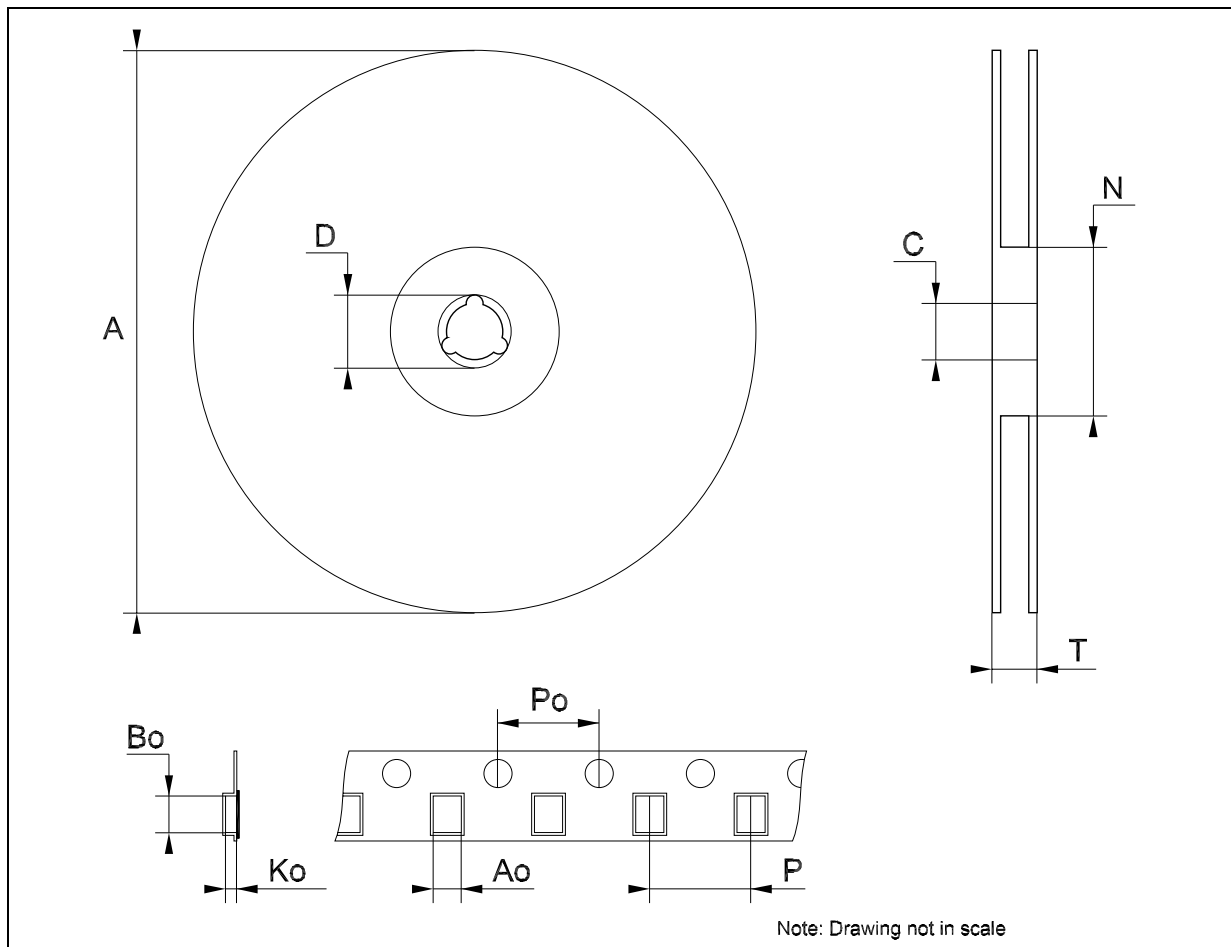

Tape & Reel SO-8 MECHANICAL DATA

| DIM. | mm. | | | inch | | |
|------|------|-----|------|-------|------|--------|
| | MIN. | TYP | MAX. | MIN. | TYP. | MAX. |
| A | | | 330 | | | 12.992 |
| C | 12.8 | | 13.2 | 0.504 | | 0.519 |
| D | 20.2 | | | 0.795 | | |
| N | 60 | | | 2.362 | | |
| T | | | 22.4 | | | 0.882 |
| Ao | 8.1 | | 8.5 | 0.319 | | 0.335 |
| Bo | 5.5 | | 5.9 | 0.216 | | 0.232 |
| Ko | 2.1 | | 2.3 | 0.082 | | 0.090 |
| Po | 3.9 | | 4.1 | 0.153 | | 0.161 |
| P | 7.9 | | 8.1 | 0.311 | | 0.319 |

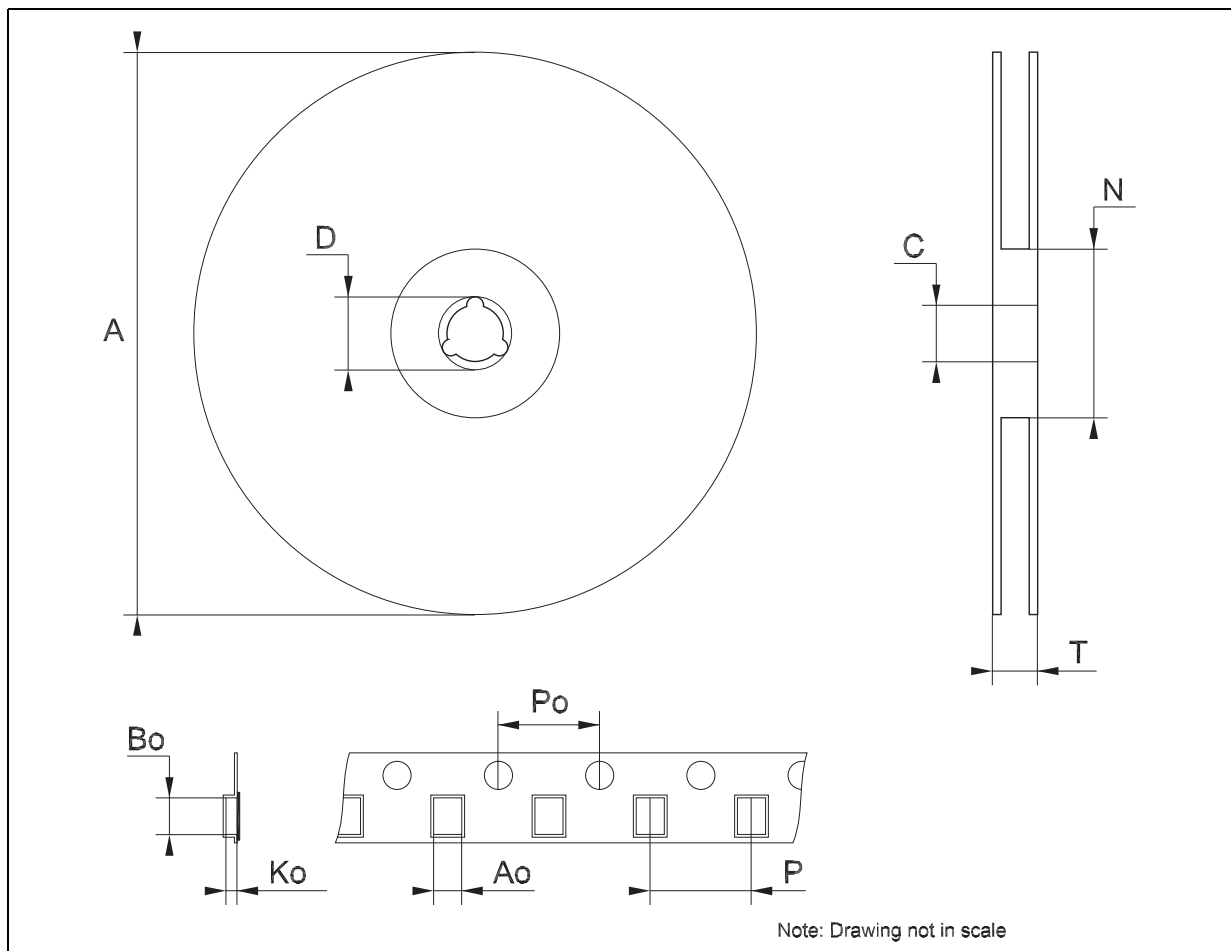

Tape & Reel for TO-92 MECHANICAL DATA

| DIM. | mm. | | | inch | | |
|---------|-------|-------|-------|-------|--------|-------|
| | MIN. | TYP | MAX. | MIN. | TYP. | MAX. |
| A1 | | 4.80 | | | 0.189 | |
| T | | 3.80 | | | 0.150 | |
| T1 | | 1.60 | | | 0.063 | |
| T2 | | 2.30 | | | 0.091 | |
| d | | 0.48 | | | 0.019 | |
| P0 | 12.5 | | 12.9 | 0.492 | | 0.508 |
| P2 | 5.65 | | 7.05 | 0.222 | | 0.278 |
| F1, F2 | 2.44 | 2.54 | 2.94 | 0.096 | 0.100 | 0.116 |
| delta H | | ±2 | | | 0.079 | |
| W | 17.5 | 18.00 | 19.0 | 0.689 | 0.709 | 0.748 |
| W0 | 5.7 | | 6.3 | 0.224 | | 0.248 |
| W1 | 8.5 | | 9.25 | 0.335 | | 0.364 |
| W2 | | 0.50 | | | 0.20 | |
| H | | 18.50 | 18.70 | | 0.728 | 0.726 |
| H0 | 15.50 | | 16.50 | 0.610 | | 0.650 |
| H1 | | 25.00 | | | 0.984 | |
| D0 | 3.8 | | 4.2 | 0.150 | | 0.165 |
| t | | 0.90 | | | 0.035 | |
| L1 | | 3 | | | 0.118 | |
| delta P | | ±1 | | | 0.039 | |
| u | | 50 | | | 1.968 | |
| Φ1 | | 360 | | | 14.173 | |
| Φ2 | | 30 | | | 1.181 | |

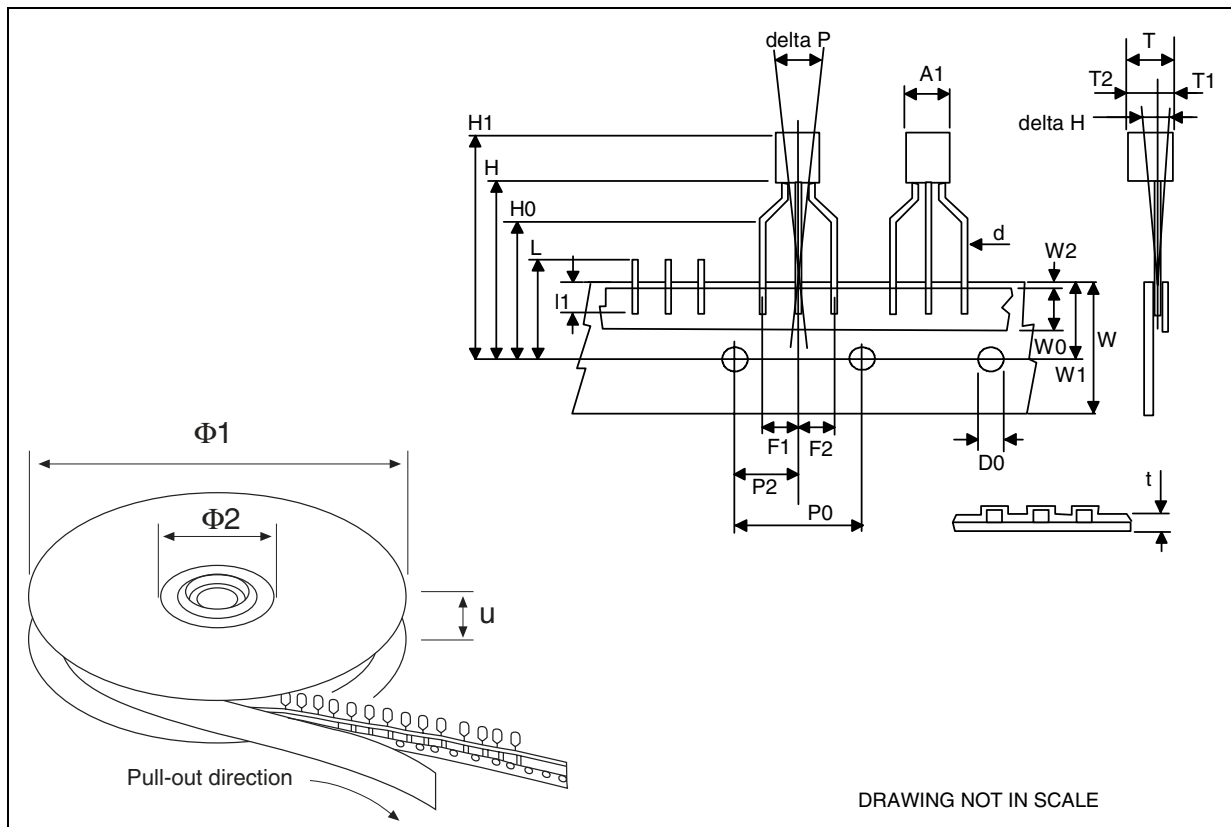

7 Order code

Table 25. Order code

| Part numbers | | | | | |
|---------------------------|----------------|------------------------------|----------------------------|------------------------------|----------------|
| TO-220 | SO-8 | PPAK | DPAK | TO-92 | Output voltage |
| L4931CV15 | L4931CD15-TR | L4931CPT15-TR ⁽¹⁾ | L4931CDT15 ⁽¹⁾ | L4931CZ15-AP ⁽¹⁾ | 1.5 V |
| L4931ABV15 ⁽¹⁾ | L4931ABD15-TR | L4931ABPT15TR ⁽¹⁾ | L4931ABDT15 ⁽¹⁾ | L4931ABZ15-AP ⁽¹⁾ | 1.5 V |
| L4931CV25 | L4931CD25-TR | L4931CPT25-TR | L4931CDT25 | L4931CZ25-AP | 2.5 V |
| L4931ABV25 | L4931ABD25-TR | L4931ABPT25TR | L4931ABDT25 | L4931ABZ25-AP | 2.5 V |
| L4931CV27 | L4931CD27-TR | L4931CPT27-TR | L4931CDT27 | L4931CZ27-AP | 2.7 V |
| L4931ABV27 | L4931ABD27-TR | L4931ABPT27TR | L4931ABDT27 | L4931ABZ27-AP | 2.7 V |
| L4931CV30 | L4931CD30-TR | L4931CPT30-TR | L4931CDT30 | L4931CZ30-AP | 3 V |
| L4931ABV30 | L4931ABD30-TR | L4931ABPT30TR | L4931ABDT30 | L4931ABZ30-AP | 3 V |
| L4931CV33 | L4931CD33-TR | L4931CPT33-TR | L4931CDT33 | L4931CZ33-AP | 3.3 V |
| L4931ABV33 | L4931ABD33-TR | L4931ABPT33TR | L4931ABDT33 | L4931ABZ33-AP | 3.3 V |
| L4931CV35 | L4931CD35-TR | L4931CPT35-TR | L4931CDT35 | L4931CZ35-AP | 3.5 V |
| L4931ABV35 | L4931ABD35-TR | L4931ABPT35TR | L4931ABDT35 | L4931ABZ35-AP | 3.5 V |
| L4931CV40 | L4931CD40-TR | L4931CPT40-TR | L4931CDT40 | L4931CZ40-AP | 4 V |
| L4931ABV40 | L4931ABD40-TR | L4931ABPT40TR | L4931ABDT40 | L4931ABZ40-AP | 4 V |
| L4931CV47 | L4931CD47-TR | L4931CPT47-TR | L4931CDT47 | L4931CZ47-AP | 4.75 V |
| L4931ABV47 | L4931ABD47-TR | L4931ABPT47TR | L4931ABDT47 | L4931ABZ47-AP | 4.75 V |
| L4931CV50 | L4931CD50-TR | L4931CPT50-TR | L4931CDT50 | L4931CZ50-AP | 5 V |
| L4931ABV50 | L4931ABD50-TR | L4931ABPT50TR | L4931ABDT50 | L4931ABZ50-AP | 5 V |
| L4931CV80 | L4931CD80-TR | L4931CPT80-TR | L4931CDT80 | L4931CZ80-AP | 8 V |
| L4931ABV80 | L4931ABD80-TR | L4931ABPT80TR | L4931ABDT80 | L4931ABZ80-AP | 8 V |
| L4931CV120 | L4931CD120-TR | L4931CPT120-TR | L4931CDT120 | L4931CZ120-AP | 12 V |
| L4931ABV120 | L4931ABD120-TR | L4931ABPT120R | L4931ABDT120 | L4931ABZ120AP | 12 V |

1. Available on request.

8 Revision history

Table 26. Revision history

| Date | Revision | Changes |
|-------------|----------|--|
| 21-Jun-2004 | 11 | Document updating. |
| 14-Jun-2006 | 12 | Order Codes has been updated and new template. |

Please Read Carefully:

Information in this document is provided solely in connection with ST products. STMicroelectronics NV and its subsidiaries ("ST") reserve the right to make changes, corrections, modifications or improvements, to this document, and the products and services described herein at any time, without notice.

All ST products are sold pursuant to ST's terms and conditions of sale.

Purchasers are solely responsible for the choice, selection and use of the ST products and services described herein, and ST assumes no liability whatsoever relating to the choice, selection or use of the ST products and services described herein.

No license, express or implied, by estoppel or otherwise, to any intellectual property rights is granted under this document. If any part of this document refers to any third party products or services it shall not be deemed a license grant by ST for the use of such third party products or services, or any intellectual property contained therein or considered as a warranty covering the use in any manner whatsoever of such third party products or services or any intellectual property contained therein.

UNLESS OTHERWISE SET FORTH IN ST'S TERMS AND CONDITIONS OF SALE ST DISCLAIMS ANY EXPRESS OR IMPLIED WARRANTY WITH RESPECT TO THE USE AND/OR SALE OF ST PRODUCTS INCLUDING WITHOUT LIMITATION IMPLIED WARRANTIES OF MERCHANTABILITY, FITNESS FOR A PARTICULAR PURPOSE (AND THEIR EQUIVALENTS UNDER THE LAWS OF ANY JURISDICTION), OR INFRINGEMENT OF ANY PATENT, COPYRIGHT OR OTHER INTELLECTUAL PROPERTY RIGHT.

UNLESS EXPRESSLY APPROVED IN WRITING BY AN AUTHORIZED REPRESENTATIVE OF ST, ST PRODUCTS ARE NOT DESIGNED, AUTHORIZED OR WARRANTED FOR USE IN MILITARY, AIR CRAFT, SPACE, LIFE SAVING, OR LIFE SUSTAINING APPLICATIONS, NOR IN PRODUCTS OR SYSTEMS, WHERE FAILURE OR MALFUNCTION MAY RESULT IN PERSONAL INJURY, DEATH, OR SEVERE PROPERTY OR ENVIRONMENTAL DAMAGE.

Resale of ST products with provisions different from the statements and/or technical features set forth in this document shall immediately void any warranty granted by ST for the ST product or service described herein and shall not create or extend in any manner whatsoever, any liability of ST.

ST and the ST logo are trademarks or registered trademarks of ST in various countries.

Information in this document supersedes and replaces all information previously supplied.

The ST logo is a registered trademark of STMicroelectronics. All other names are the property of their respective owners.

© 2006 STMicroelectronics - All rights reserved



STMicroelectronics group of companies

Australia - Belgium - Brazil - Canada - China - Czech Republic - Finland - France - Germany - Hong Kong - India - Israel - Italy - Japan - Malaysia - Malta - Morocco - Singapore - Spain - Sweden - Switzerland - United Kingdom - United States of America



www.st.com

Looking for pricing, stock, or lifecycle information?

Click below to explore more details on WIN SOURCE:

-  [View L4931ABDT120R on WIN SOURCE](#)
-  [STMicroelectronics](#) Information

Optimize Your Supply Chain with WIN SOURCE Solutions

-  Global Sourcing Solution
-  Obsolete Management
-  Cost Control Management
-  Shortage Management
-  Alternative Solution
-  Excess Inventory Management