



**THE DATASHEET OF
L4938EPD13TR**



Advanced voltage regulator

Features

- Enable and sense inputs (EN, SI) protected against negative transients down to -5 V
- Reset threshold adjustable from 3.8 V to 4.7 V
- Extremely low quiescent current, 65 μ A (less than 90 μ A) in standby mode
- Operating DC supply voltage range 5 V - 28 V
- Operating transient supply voltage up to 40 V
- High precision standby output voltage 5 V \pm 1% with 100 mA current capability
- Output 2 voltage 5 V \pm 2% with 400 mA current capability (ADJ wired to V_{OUT2})
- Output 2 voltage adjustable by external voltage divider
- Output 2 disable function for standby mode

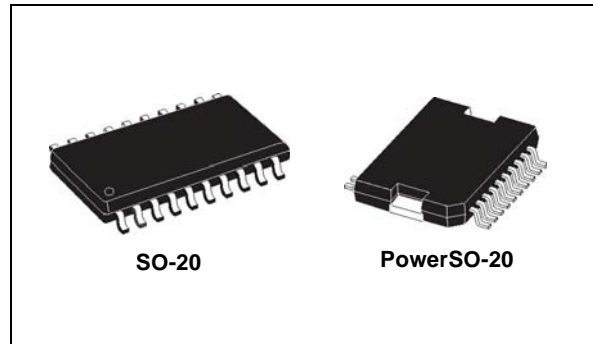

Description

The L4938ED and L4938EPD are monolithic integrated dual voltage regulators with two very low dropout outputs and additional functions such as power-on reset and input voltage sense. They are designed for supplying microcomputer controlled systems especially in automotive applications.

Table 1. Device summary

Package	Order codes	
	Tube	Tape and reel
SO-20	L4938ED	L4938ED013TR
PowerSO-20	L4938EPD	L4938EPD13TR

Contents

- 1 Block diagram and pin description 5**
- 2 Electrical specifications 7**
 - 2.1 Absolute maximum ratings 7
 - 2.2 Thermal data 8
 - 2.3 Electrical characteristics 8
- 3 Application information 11**
 - 3.1 Functional description11
 - 3.2 Standby regulator11
 - 3.3 Output 2 voltage 12
 - 3.4 Reset circuit 12
 - 3.5 Sense comparator 13
 - 3.6 Thermal protection 13
 - 3.7 Transient sensitivity 13
 - 3.8 Input protection 15
- 4 Package and packing information 16**
 - 4.1 ECOPACK® packages 16
 - 4.2 SO-20 package information 16
 - 4.3 PowerSO-20 package information 17
- 5 Revision history 19**

List of tables

Table 1.	Device summary	1
Table 2.	Pin definitions and functions	6
Table 3.	Absolute maximum ratings	7
Table 4.	Thermal data	8
Table 5.	OUT1	8
Table 6.	OUT2	8
Table 7.	OUT1, OUT2	9
Table 8.	Enable input	9
Table 9.	Reset circuit	9
Table 10.	Sense comparator	10
Table 11.	SO-20 mechanical data	16
Table 12.	PowerSO-20 mechanical data	17
Table 13.	Document revision history	19

List of figures

Figure 1.	Block diagram	5
Figure 2.	Configuration diagram (top view)	5
Figure 3.	Application diagram	11
Figure 4.	OUT2	12
Figure 5.	Reset generator	14
Figure 6.	Waveforms	14
Figure 7.	Input protection	15
Figure 8.	Input characteristics of SI, EN	15
Figure 9.	SO-20 package dimensions	17
Figure 10.	PowerSO-20 package dimensions	18

1 Block diagram and pin description

Figure 1. Block diagram

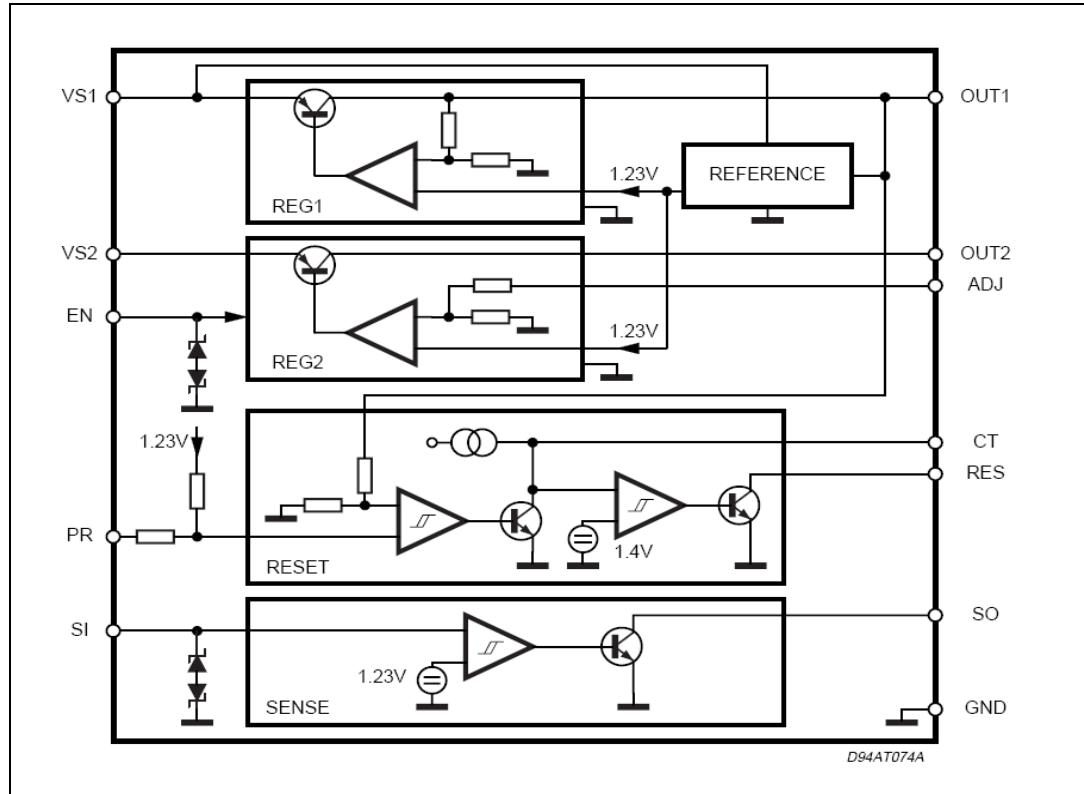

Figure 2. Configuration diagram (top view)

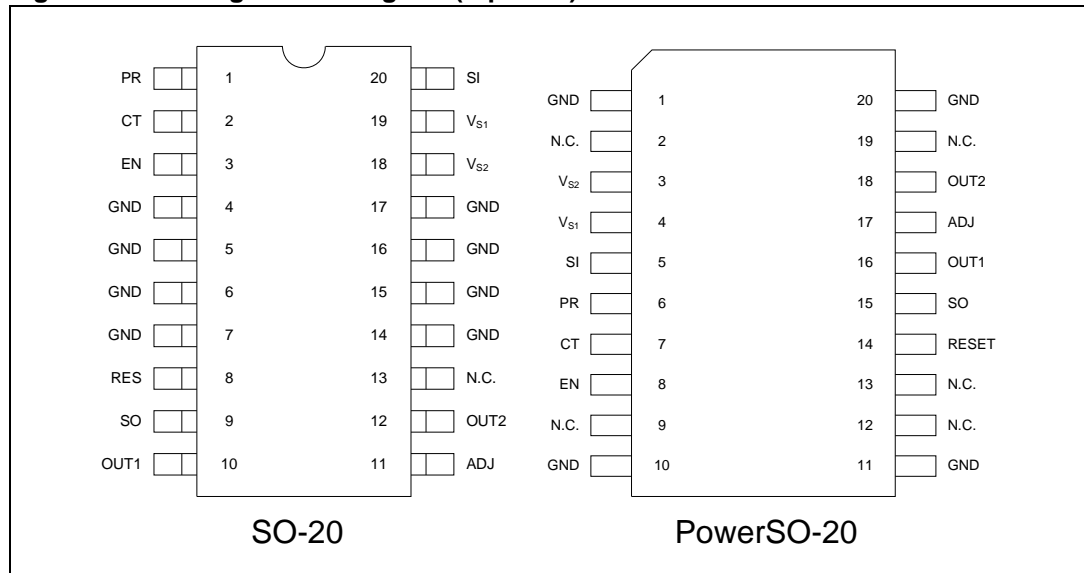

Table 2. Pin definitions and functions

Pin number		Name	Function
SO-20	PowerSO-20		
18	3	V _{S2}	Supply voltage (400 mA regulator)
19	4	V _{S1}	Supply voltage (100 mA regulator, reset, sense)
20	5	SI	Sense input
1	6	PR	Reset threshold programming
2	7	CT	Reset delay capacitor
3	8	EN	Enable (low activates the 400 mA regulator)
4, 5, 6, 7, 14, 15, 16, 17	1, 10, 11, 20	GND	Ground
8	14	RES	Reset output
9	15	SO	Sense output
10	16	OUT1	100 mA regulator output
11	17	ADJ	Feedback of 400 mA regulator
12	18	OUT2	400 mA regulator output
13	2, 9, 19	NC	Not connected

2 Electrical specifications

2.1 Absolute maximum ratings

Stressing the device above the ratings listed in the “Absolute maximum ratings” tables may cause permanent damage to the device. These are stress ratings only and operation of the device at these or any other conditions above those indicated in the Operating sections of this specification is not implied. Exposure to the conditions in this section for extended periods may affect device reliability. Refer also to the STMicroelectronics SURE Program and other relevant quality documents.

Table 3. Absolute maximum ratings

Symbol	Parameter	Value	Unit
V_{INDC}	DC operating supply voltage	28	V
V_{INTR}	Transient operating supply voltage (T < 400 ms)	-14 to 40	V
I_O	Output current	internally limited	
V_{SI}	Sense input voltage (voltage forced) ⁽¹⁾	-20 to 20	V
I_{SI}	Sense input current (current forced) ⁽¹⁾	±1	mA
V_{EN}	Enable input voltage (voltage forced) ⁽¹⁾	-20 to 20	V
I_{EN}	Sense input current (current forced) ⁽¹⁾	±1	mA
V_{RES}, V_{SO}	Output voltages	-0.3 to 20	V
I_{RES}, I_{SO}	Output currents (output low)	5	mA
P_O	Power dissipation at $T_{amb} = 80\text{ °C}$ ⁽²⁾	875	mW
T_{stg}	Storage temperature	-65 to 150	°C
T_J	Operating junction temperature	-40 to 150	°C
T_{JSD}	Thermal shutdown junction temperature output 2 will shutdown typically at T_J 10 K lower than output 1	165	°C

1. Current forced means voltage unlimited but current limited to the specified value voltage forced means voltage limited to the specified values while the current is not limited
2. Typical value soldered on a PC board with 8 cm² copper ground plane (35 mm thick).

Note: The circuit is ESD protected according to MIL-STD-883C.

2.2 Thermal data

Table 4. Thermal data

Symbol	Parameter	SO-20	PowerSO-20	Unit
$R_{thj-amb}$	Thermal resistance junction to ambient	50	-	°C/W
$R_{thj-case}$	Thermal resistance junction to case	-	< 2	°C/W

Note: Typical value soldered on a PC board with 8 cm² copper ground plane (35 mm thick).

2.3 Electrical characteristics

$V_S = 14\text{ V}$; $T_j = -40\text{ to }150\text{ °C}$, unless otherwise specified.

Table 5. OUT1

Symbol	Parameter	Test condition	Min.	Typ.	Max.	Unit
V_{O1}	Supply output voltage	$V_S = 6\text{ to }28\text{ V}$; $I_{O1} = 400\text{ }\mu\text{A to }100\text{ mA}$	4.9	5	5.1	V
		$T_J \leq 125\text{ °C}$; $I_{O1} = 50\text{ to }400\text{ }\mu\text{A}$	4.8	5	5.2	V
V_{DP1}	Drop output voltage 1	$I_{OUT1} = 10\text{ mA}$		0.1	0.2	V
		$I_{OUT1} = 100\text{ mA}$; $V_S = 4.8\text{ V}$		0.2	0.4	V
V_{OL01}	Load regulation 1	$I_{OUT1} = 1\text{ to }100\text{ mA}$ (after regulation setting)			25	mV
V_{LIM1}	Current limit 1	$V_{OUT1} = 0.8\text{ to }4.5\text{ V}$	100	200	400	mA
I_{QSB}	Quiescent current in standby mode	$I_{EN} \geq 2.4\text{ V}$ (output 2 disabled) $I_{O1} = 0.1\text{ mA}$; $V_{SI} > 1.3\text{ V}$		65	90	μA
		$T_J < 85\text{ °C}$; $R_{PR} = 0$		75		μA

Table 6. OUT2

Symbol	Parameter	Test condition	Min.	Typ.	Max.	Unit
V_{O2}	Output voltage 2 ADJ connected to OUT2	Enable = low; $V_S = 6\text{ to }28\text{ V}$; $I_{O2} = 5\text{ to }400\text{ mA}$	4.9		5.1	V
V_{DP2}	Drop output voltage 2	$I_{OUT2} = 100\text{ mA}$		0.2	0.3	V
		$I_{OUT2} = 400\text{ mA}$; $V_S = 4.8\text{ V}$		0.3	0.6	V
V_{OL02}	Load regulation 2	$I_{OUT1} = 5\text{ to }400\text{ mA}$ (after regulation setting)			50	mV
R_{ADJ}	Adjust input resistance		60	100	150	mA
I_{LIM2}	Current limit 2	$V_{O2} = 0.8\text{ to }4.5\text{ V}$	450	650	1300	mA
I_Q	Quiescent current	$I_{OUT1} = 100\text{ mA}$; $I_{OUT2} = 400\text{ mA}$			20	mA

Table 7. OUT1, OUT2

Symbol	Parameter	Test condition	Min.	Typ.	Max.	Unit
$V_{OLi\ 1,2}$	Line regulation	$V_S = 6$ to 28 V; $I_{O1} = 1$ mA, $I_{O2} = 5$ mA, (after regulation setting)			20	mV

Table 8. Enable input

Symbol	Parameter	Test condition	Min.	Typ.	Max.	Unit
V_{ENL}	Enable input low voltage (output 2 active)		-20		1	V
V_{ENH}	Enable input high voltage		1.4		20	V
V_{ENhyst}	Enable hysteresis		20	30	60	mV
$I_{EN\ LOW}$	Enable input current low	$V_{EN} = 0$	-20	-8	-3	μ A
$I_{EN\ HIGH}$	Enable input current high	$V_{EN} = 1.1$ to 7 V; $T_J < 130$ °C;	-1	0	1	μ A
		$V_{EN} = 1.1$ to 7 V; $T_J = 130$ to 150 °C;	-10	0	10	μ A

Table 9. Reset circuit

Symbol	Parameter	Test condition	Min.	Typ.	Max.	Unit
V_{RT}	Reset threshold voltage ⁽¹⁾	$R_{PR} = \infty$	4.5	$V_{O1-0.3}$	$V_{O1-0.2}$	V
		$R_{PR} = 0$	3.65	3.8	3.95	V
V_{RTH}	Reset threshold hysteresis	$R_{PR} = \infty$	30	60	120	mV
$t_{RD\ min}$	Reset pulse delay	$C_{RES} = 47$ nF; $t_r \leq 30$ μ s ⁽²⁾	40	60	100	ms
$t_{RD\ nom}$	Reset pulse delay	$C_{RES} = 47$ nF ⁽³⁾	60	100	140	ms
t_{RR}	Reset reaction time	$C_{RES} = 47$ nF	10	50	150	μ s
I_{CT}	Pull down capability of the discharge circuit	$V_{OUT1} < V_{RT}$	3	6	15	mA
I_{CT}	Charge current	$V_{OUT1} > V_{RT}$	-1.3	-1	0.7	μ A
V_{RESL}	Reset output low voltage	$R_{RES} = 10$ K Ω to V_{OUT1} $V_{OUT1} \geq 1.5$ V			0.4	V
V_{RESH}	Reset output high leakage current	$V_{RES} = 5$ V			1	μ A

1. The reset threshold can be programmed continuously from typ 3.8 V to 4.7 V by changing a value of an external resistor from pin PR to GND.
2. This is a minimum reset time according to the hysteresis of the comparator. Delay time starts with V_{OUT1} exceeding V_{RT} .
3. This is the nominal reset time depending on the discharging limit of C_T (saturation voltage) and the upper threshold of the timer comparator. Delay time starts with V_{OUT1} exceeding V_{RT} .

Table 10. Sense comparator

Symbol	Parameter	Test condition	Min.	Typ.	Max.	Unit
V_{SI}	Functional range		-20		20	V
V_{SIT}	Sense threshold voltage	Falling edge; $T_J < 130\text{ °C}$	1.08	1.16	1.24	V
		Falling edge; $T_J < 130\text{ to }150\text{ °C}$	1.05	1.16	1.29	V
V_{SITH}	Sense threshold hysteresis		10	30	60	mV
V_{SOL}	Sense output low voltage	$V_{SI} \leq 1.05\text{ V}$; $R_{SO} = 10\text{ K}\Omega$ connected to 5 V; $V_S \geq 5\text{ V}$			0.4	V
I_{SOH}	Sense output leakage	$V_{SO} = 5\text{ V}$; $V_{SI} \geq 1.5\text{ V}$			1	μA
$I_{SI\text{ HIGH}}$	Sense input current high	$V_{SI} = 1.1\text{ to }7\text{ V}$; $T_J < 130\text{ °C}$	-1	0	1	μA
		$V_{SI} = 1.1\text{ to }7\text{ V}$; $T_J < 130\text{ to }150\text{ °C}$	-10	0	10	μA
$I_{SI\text{ LOW}}$	Sense input current low	$V_{SI} = 0\text{ V}$	-20	-8	-3	μA

3 Application information

Figure 3. Application diagram

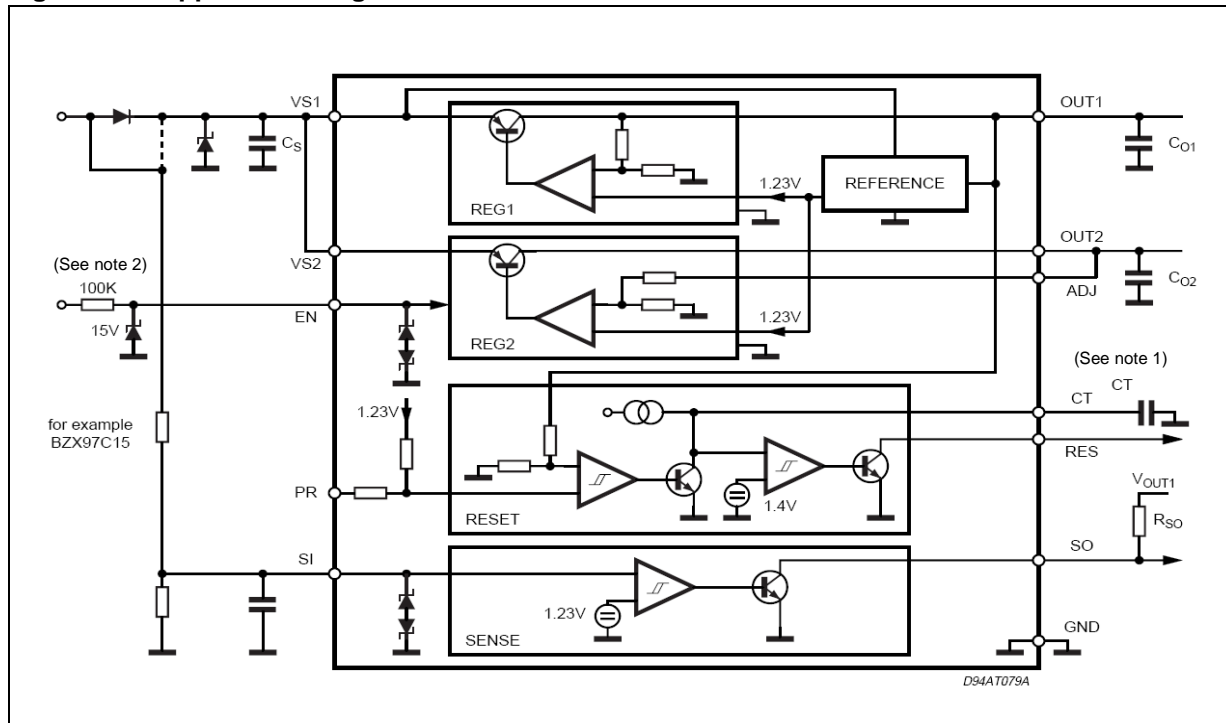

1. The leakage of C_T must be less than 0.5 mA (2 V). If an external resistor between C_T and V_{OUT1} is applied, the leakage current may be increased. The external resistor should have more than 30 K Ω . For stability: $C_s \geq 1 \mu\text{F}$, $C_{01} \geq 10 \mu\text{F}$, $C_{02} \geq 10 \mu\text{F}$, $\text{ESR} \leq 5 \Omega$ (designed target).
2. For transients exceeding 20 V or -20 V external protection is required at the pins SI and EN as shown at pin EN. The protection proposed provides proper function for transients in the range of $\pm 200 \text{ V}$. If the zener diode is omitted the external resistor should be raised to 200 K Ω to limit the current to 1 mA. Without the zener diode, the function 20 V or -20 V can not be guaranteed.

3.1 Functional description

The L4938ED and L4938EPD are monolithic integrated dual voltage regulators, based on the STM modulator voltage regulator approach. Several outstanding features and auxiliary functions are implemented to meet the requirements of supplying microprocessor systems in automotive applications. Nevertheless, it is suitable also in other applications where two stabilized voltages are required. The modular approach of this device allows to get easy also other features and functions when required.

3.2 Standby regulator

The standby regulator uses an isolated collector vertical PNP transistor as a regulating element. With this structure very low dropout voltage at currents up to 100 mA is obtained. The dropout operation of the standby regulator is maintained down to 3 V input supply voltage. The output voltage is regulated up to the transient input supply voltage of 40 V. With this feature no functional interruption due to overvoltage pulses is generated.

In the standby mode when the output 2 is disabled, the current consumption of the device (quiescent current) is less than 90 μA (14 V supply voltage).

To reduce the quiescent current peak in the undervoltage region and to improve the transient response in this region, the dropout voltage is controlled. A second regulation path keeps the output voltage without load below 5.5 V even at high temperatures.

3.3 Output 2 voltage

The output 2 regulator uses the same output structure as the standby regulator but rated for the output current of 400 mA. The output voltage is internally fixed to 5 V if ADJ is connected to $V_{\text{OUT}2}$. The output 2 regulator can be switches OFF via the enable input.

Figure 4. OUT2

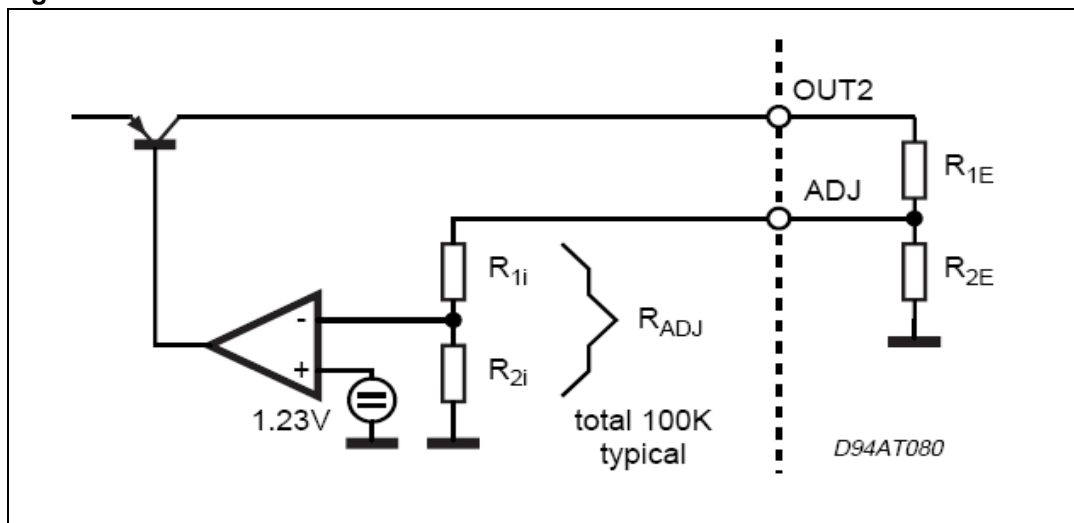

Connecting a resistor divider R_{1E} , R_{2E} to the ADJ, OUT2 pin the output voltage 2 can be programmed to the value of

$$V_{\text{OUT}2} = V_{\text{OUT}1} \left(1 + \frac{R_{1E}(R_{2E} + R_{\text{ADJ}})}{R_{2E} \cdot R_{\text{ADJ}}} \right)$$

with $R_{\text{ADJ}} = 60 \text{ K}$ to 150 K and $V_{\text{OUT}1} = 4.95$ to 5.05 V . For an exact calculation the temperature coefficient ($T_C - 2000 \text{ ppm}$) of the internal resistor (R_{ADJ}) must be taken into account. Pin ADJ in this mode should not have a capacitive burden because this would reduce the phase margin of the regulator loop.

3.4 Reset circuit

The reset circuit supervises the standby output voltage. The reset output (RES) is defined from $V_{\text{OUT}} \geq 1 \text{ V}$. Even if V_S is lacking, the reset generator is supplied by the output voltage $V_{\text{OUT}1}$.

The reset threshold of 4.7 V is defined with the internal reference voltage^(a) and standby output divider, when pin PR is left open. The reset threshold voltage can be programmed in the range from 3.8 V to 4.7 V by connecting an external resistor from pin PR to GND.

The value of the programming resistor R_{PR} can be calculated with:

$$R_{PR} = \frac{22K}{\frac{4.7K}{V_{RT}} - 1} - 92.9K$$

$$3.8V \leq V_{RT} \leq 4.7V$$

The reset pulse delay time t_{RD} , is defined with the charge time of an external capacitor C_T :

$$t_{RDmin} = \frac{C_T \cdot 0.6V}{1\mu A}$$

$$t_{RDnom} = \frac{C_T \cdot 1.4V}{1\mu A}$$

The reaction time of the reset circuit originates from the noise immunity. Standby output voltage drops below the reset threshold only a bit longer than the reaction time results in a shorter reset delay time. The nominal reset delay time is generated for standby output voltage drops longer than approximately 50 μs . The minimum reset time is generated if reset condition only occurs for a short time triggering a reset pulse but not completely discharging C_T . The reset can be related to output2 on request. If higher charge currents for the reset capacitor are required a resistors from pin C_T to OUT1, may be used to increase the current. We recommended the use of 10 K Ω to 5 V as an output pull up.

3.5 Sense comparator

The sense comparator compares an input signal with an internal voltage reference of typical 1.23 V. The use of an external voltage divider makes this comparator very flexible in the application. It can be used to supervise the input voltage either before or after the protection diode and to give additional information to the microprocessor like low voltage warnings. We recommended the use of 10 K Ω to 5 V as an output pull up.

3.6 Thermal protection

Both outputs are provided with an overtemperature shutdown regulation power dissipation down to uncritical values. Output 2 shuts down approximately 10 K before output 1. Under normal conditions shutdown of output 2 allows the chip to cool down again. Thus output 1 is unaffected. The thermal shutdown reduces the output voltages until power dissipation and the flow of thermal energy out of the chip balance.

3.7 Transient sensitivity

In proper operation ($V_{OUT} > 4.5 V$) the reference is supplied by V_{OUT1} thus reducing sensitivity to input transients.

a. The reference is alternatively supplied from V_S or V_{OUT1} . If one supply is present, the reference is operating.

Figure 5. Reset generator

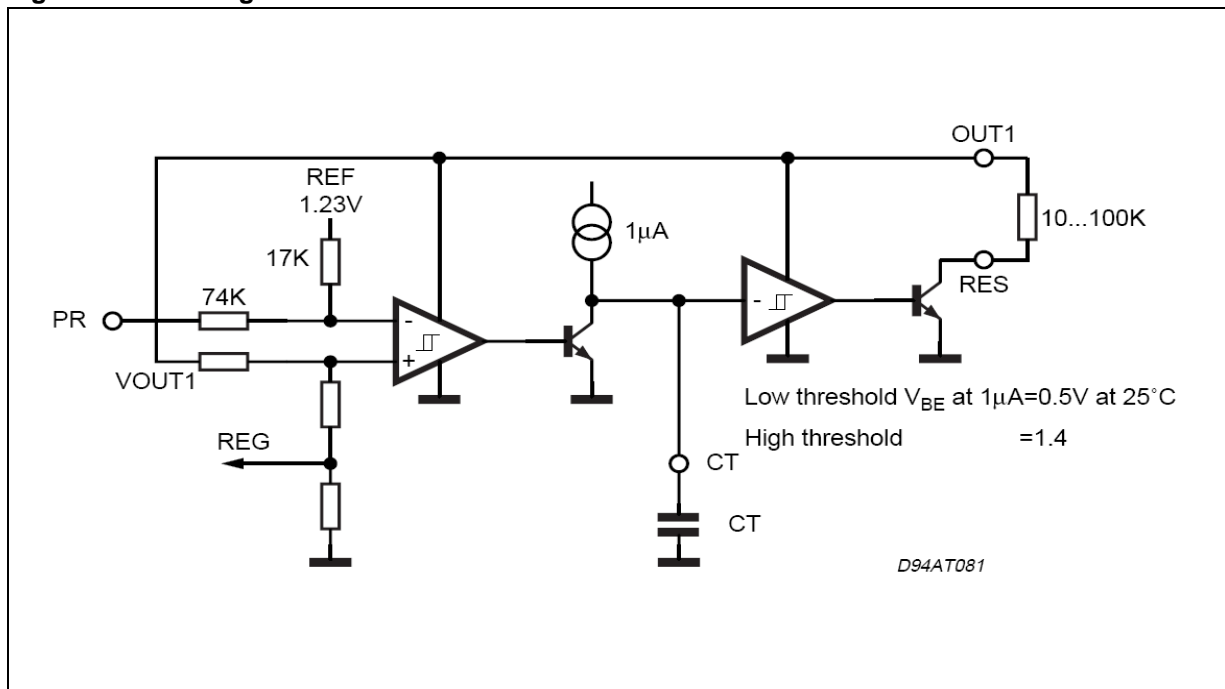
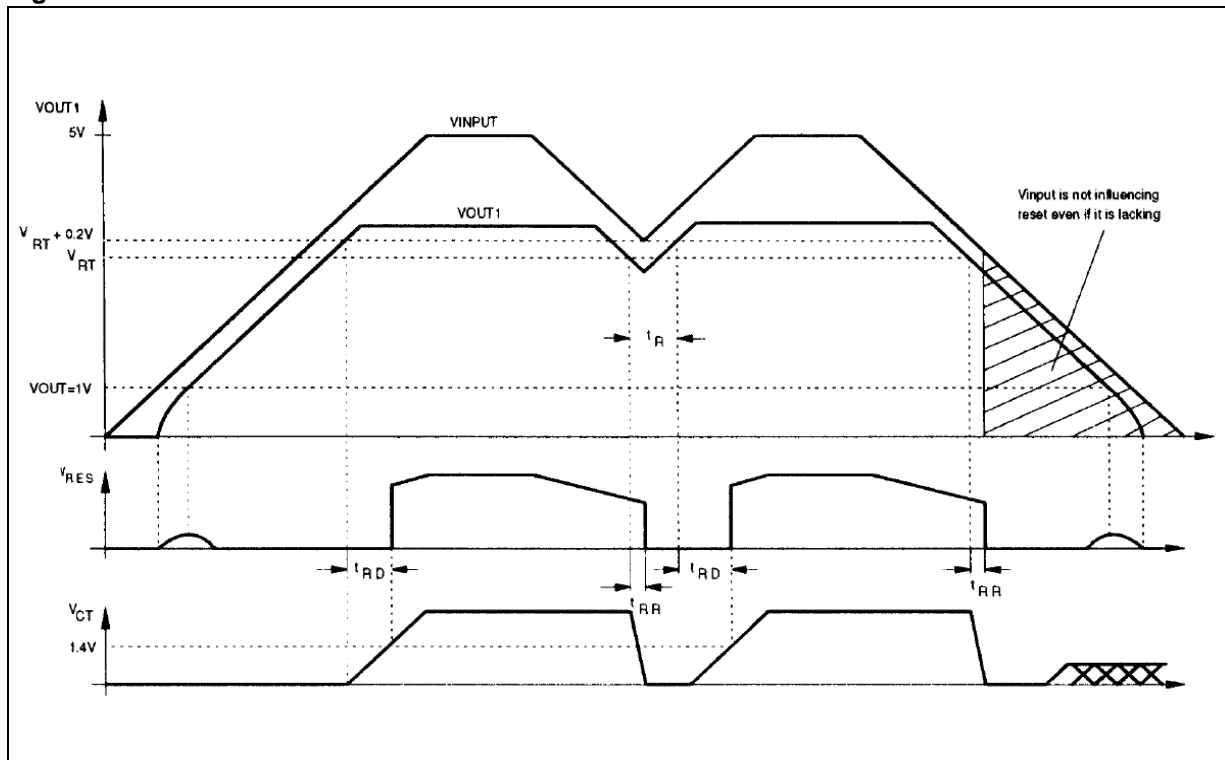

Figure 6. Waveforms



3.8 Input protection

The Inputs Enable (EN) and Sense In (SI) are protected against negative transients. *Figure 7* is showing the simplified schematic

Figure 7. Input protection

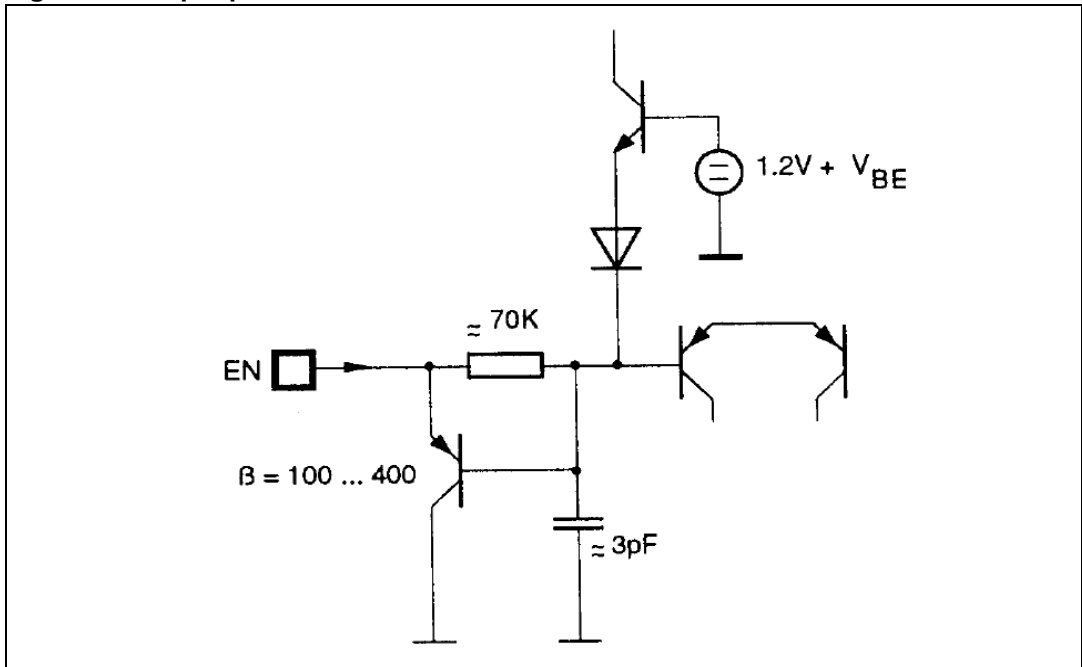
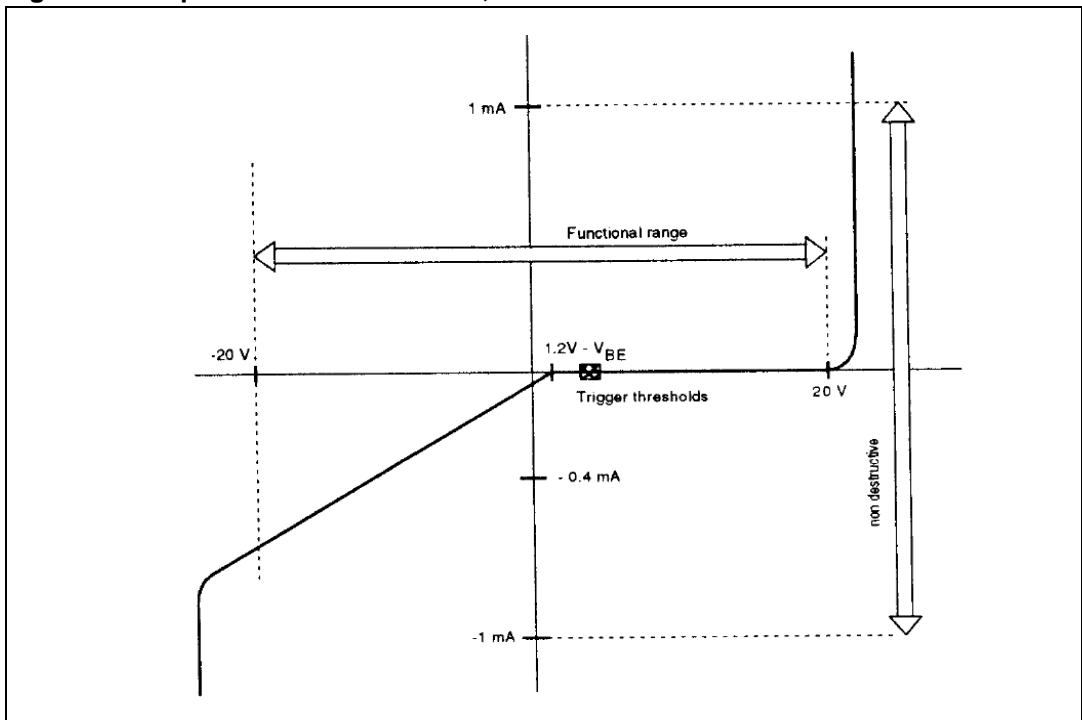

Figure 8. Input characteristics of SI, EN



4 Package and packing information

4.1 ECOPACK[®] packages

In order to meet environmental requirements, ST offers these devices in different grades of ECOPACK[®] packages, depending on their level of environmental compliance. ECOPACK[®] specifications, grade definitions and product status are available at: www.st.com.

ECOPACK[®] is an ST trademark.

4.2 SO-20 package information

Table 11. SO-20 mechanical data

Dim.	mm		
	Min.	Typ.	Max.
A	2.35		2.65
A1	0.1		0.3
B	0.33		0.51
C	0.23		0.32
D	12.6		13
E	7.4		7.6
e		1.27	
H	10		10.65
h	0.25		0.75
L	0.4		1.27
K	0°		8°

Figure 9. SO-20 package dimensions

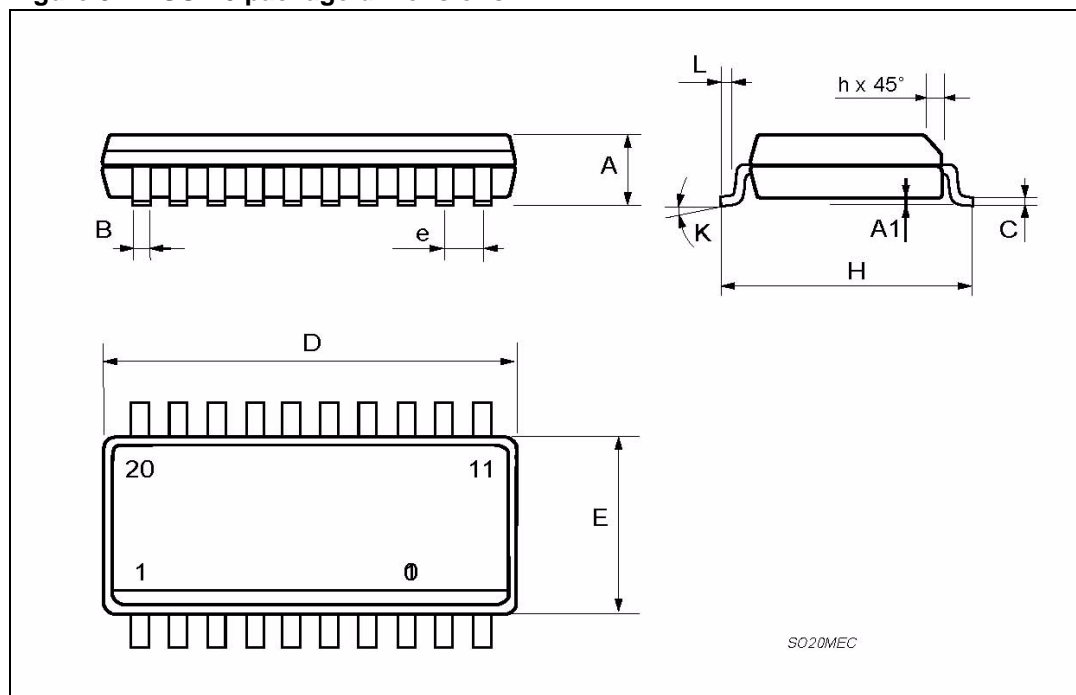

4.3 PowerSO-20 package information

Table 12. PowerSO-20 mechanical data

Dim.	mm		
	Min.	Typ.	Max.
A			3.6
a1	0.1		0.3
a2			3.3
a3	0		0.1
b	0.4		0.53
c	0.23		0.32
D ⁽¹⁾	15.8		16
D1	9.4		9.8
E	13.9		14.5
e		1.27	
e3		11.43	
E1 (1)	10.9		11.1
E2			2.9
E3	5.8		6.2

Table 12. PowerSO-20 mechanical data (continued)

Dim.	mm		
	Min.	Typ.	Max.
G	0		0.1
H	15.5		15.9
h			1.1
L	0.8		1.1
N			10°
S			8°
T		10	

- "D and F" do not include mold flash or protrusions.
 - Mold flash or protrusions shall not exceed 0.15 mm (0.006").
 - Critical dimensions: "E", "G" and "a3"

Figure 10. PowerSO-20 package dimensions

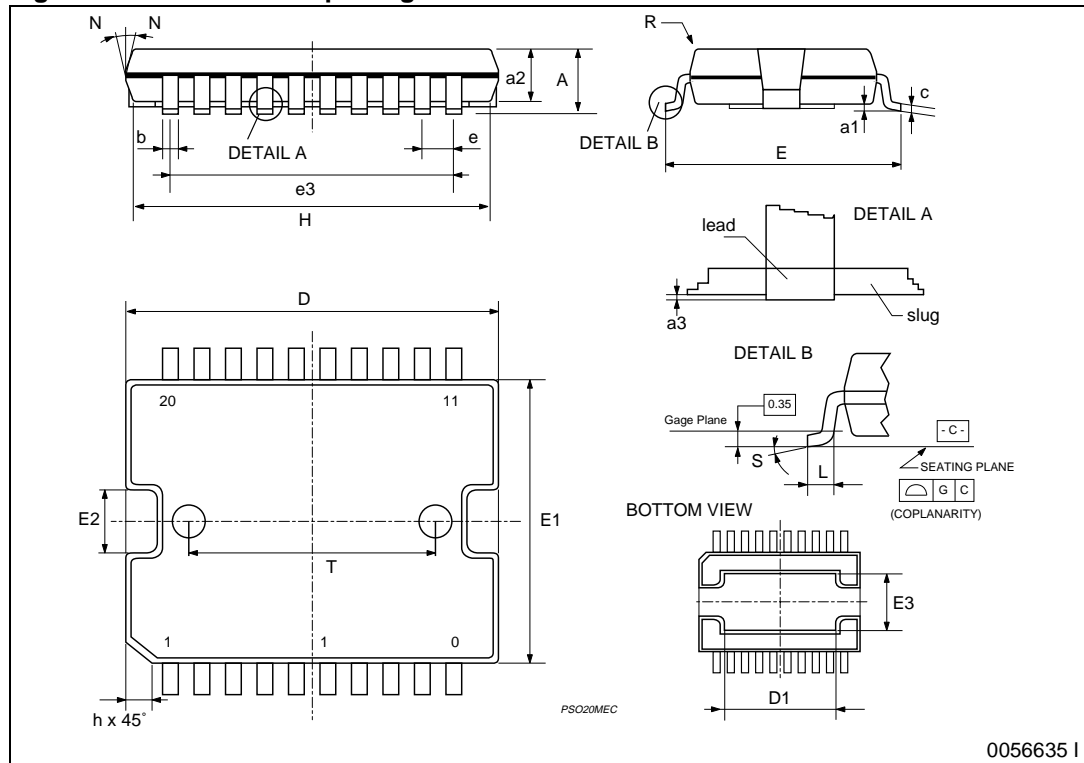

5 Revision history

Table 13. Document revision history

Date	Revision	Changes
10-Mar-2010	1	Initial release.
20-Sep-2013	2	Updated disclaimer.

Please Read Carefully:

Information in this document is provided solely in connection with ST products. STMicroelectronics NV and its subsidiaries ("ST") reserve the right to make changes, corrections, modifications or improvements, to this document, and the products and services described herein at any time, without notice.

All ST products are sold pursuant to ST's terms and conditions of sale.

Purchasers are solely responsible for the choice, selection and use of the ST products and services described herein, and ST assumes no liability whatsoever relating to the choice, selection or use of the ST products and services described herein.

No license, express or implied, by estoppel or otherwise, to any intellectual property rights is granted under this document. If any part of this document refers to any third party products or services it shall not be deemed a license grant by ST for the use of such third party products or services, or any intellectual property contained therein or considered as a warranty covering the use in any manner whatsoever of such third party products or services or any intellectual property contained therein.

UNLESS OTHERWISE SET FORTH IN ST'S TERMS AND CONDITIONS OF SALE ST DISCLAIMS ANY EXPRESS OR IMPLIED WARRANTY WITH RESPECT TO THE USE AND/OR SALE OF ST PRODUCTS INCLUDING WITHOUT LIMITATION IMPLIED WARRANTIES OF MERCHANTABILITY, FITNESS FOR A PARTICULAR PURPOSE (AND THEIR EQUIVALENTS UNDER THE LAWS OF ANY JURISDICTION), OR INFRINGEMENT OF ANY PATENT, COPYRIGHT OR OTHER INTELLECTUAL PROPERTY RIGHT.

ST PRODUCTS ARE NOT DESIGNED OR AUTHORIZED FOR USE IN: (A) SAFETY CRITICAL APPLICATIONS SUCH AS LIFE SUPPORTING, ACTIVE IMPLANTED DEVICES OR SYSTEMS WITH PRODUCT FUNCTIONAL SAFETY REQUIREMENTS; (B) AERONAUTIC APPLICATIONS; (C) AUTOMOTIVE APPLICATIONS OR ENVIRONMENTS, AND/OR (D) AEROSPACE APPLICATIONS OR ENVIRONMENTS. WHERE ST PRODUCTS ARE NOT DESIGNED FOR SUCH USE, THE PURCHASER SHALL USE PRODUCTS AT PURCHASER'S SOLE RISK, EVEN IF ST HAS BEEN INFORMED IN WRITING OF SUCH USAGE, UNLESS A PRODUCT IS EXPRESSLY DESIGNATED BY ST AS BEING INTENDED FOR "AUTOMOTIVE, AUTOMOTIVE SAFETY OR MEDICAL" INDUSTRY DOMAINS ACCORDING TO ST PRODUCT DESIGN SPECIFICATIONS. PRODUCTS FORMALLY ESCC, QML OR JAN QUALIFIED ARE DEEMED SUITABLE FOR USE IN AEROSPACE BY THE CORRESPONDING GOVERNMENTAL AGENCY.

Resale of ST products with provisions different from the statements and/or technical features set forth in this document shall immediately void any warranty granted by ST for the ST product or service described herein and shall not create or extend in any manner whatsoever, any liability of ST.

ST and the ST logo are trademarks or registered trademarks of ST in various countries.

Information in this document supersedes and replaces all information previously supplied.

The ST logo is a registered trademark of STMicroelectronics. All other names are the property of their respective owners.

© 2013 STMicroelectronics - All rights reserved



STMicroelectronics group of companies

Australia - Belgium - Brazil - Canada - China - Czech Republic - Finland - France - Germany - Hong Kong - India - Israel - Italy - Japan - Malaysia - Malta - Morocco - Philippines - Singapore - Spain - Sweden - Switzerland - United Kingdom - United States of America





www.st.com

Looking for pricing, stock, or lifecycle information?

Click below to explore more details on WIN SOURCE:

-  [View L4938EPD13TR](#) on WIN SOURCE
-  [STMicroelectronics](#) Information

Optimize Your Supply Chain with WIN SOURCE Solutions

-  Global Sourcing Solution
-  Obsolete Management
-  Cost Control Management
-  Shortage Management
-  Alternative Solution
-  Excess Inventory Management