



**THE DATASHEET OF  
L4953G**



## MULTIFUNCTION VOLTAGE REGULATOR FOR CAR RADIO

- 3 OUTPUTS:
  - 9.2V (500mA);
  - 5V (1A);
  - 5V (100mA)
- STANDBY
- OUT1 (9.2V) AND OUT2 (5V) WITH INDEPENDENT ENABLE CONTROL FOR STANDBY MODE
- 2A HIGH SIDE DRIVER WITH CLAMPED OUTPUT (16V)
  - LOGIC OUTPUT FOR:
  - SUPPLY UNDERVOLTAGE (LVW)
  - OVERVOLTAGE (FAULT)
  - THERMAL PROTECTION (FAULT)
- RESET FUNCTION
- IGNITION COMPARATOR
- REVERSE BATTERY AND LOAD DUMP PROTECTION
- THERMAL SHUTDOWN

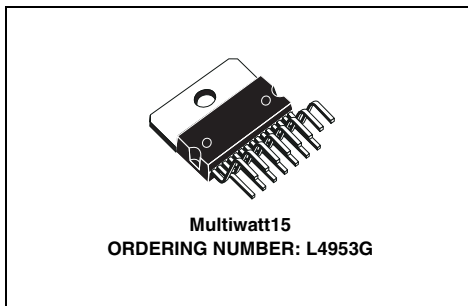

and a power switch.

The IC includes a monitoring circuit to warn if a low voltage or no voltage condition is occurring. In stand-by output is active as long as possible even when in thermal shutdown or any other fault conditions.

The STCAP pin allows the use of a reserve supply capacitor that will hold enough energy for the 5V Stand-by line to allow the  $\mu\text{P}$  to store data.

### DESCRIPTION

The L4953G contains a triple voltage regulator

### BLOCK DIAGRAM

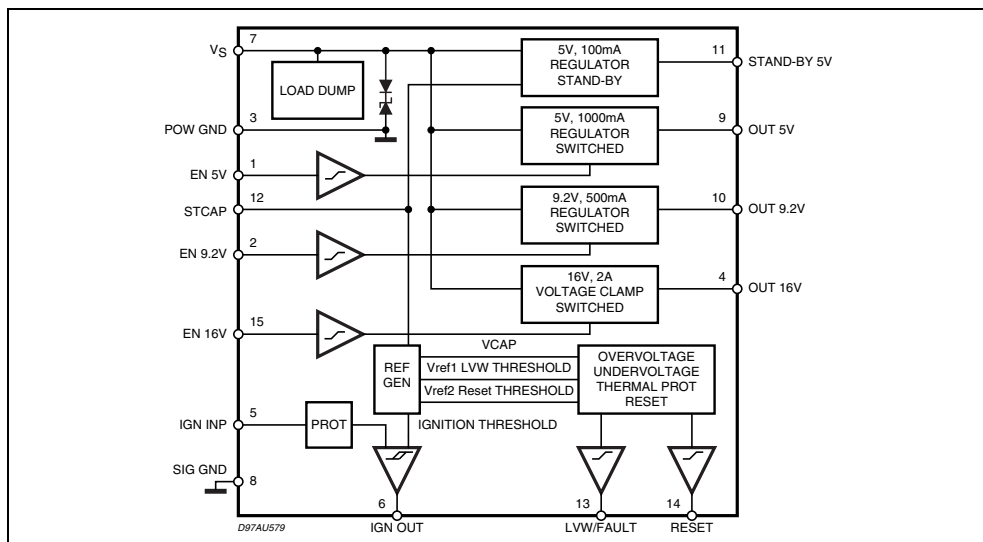

## ABSOLUTE MAXIMUM RATINGS

Symbol	Parameter	Value	Unit
$V_{SDC}$	DC Operating Supply Voltage	-0.6 to 28	V
$V_{STR}$	Transient Supply Voltage	50	V
$I_O$	Output Current	internally limited	
$T_{op}$	Operating Temperature Range	-40 to 85	°C
$T_{stg}$	Storage Temperature	-55 to 150	°C

## PIN CONNECTION (Top view)

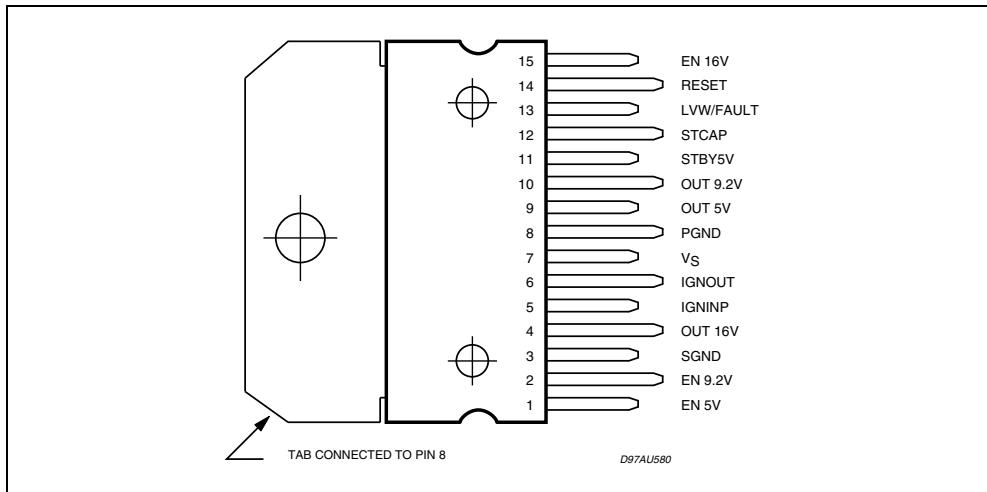

## THERMAL DATA

Symbol	Parameter	Value	Unit
$R_{th\ j-case}$	Thermal Resistance Junction-case	Max. 2	°C/W

**ELECTRICAL CHARACTERISTICS**(V<sub>S</sub> = 14V, T<sub>amb</sub> = 25°C, unless otherwise specified.)

Symbol	Parameter	Test Condition	Min.	Typ.	Max.	Unit
V <sub>S</sub>	Operating Supply Voltage		11		18	V
En	Output Noise Voltage	Any reg. supply, f = 100Hz to 200KHz		200	400	μV
<b>5V STAND-BY OUTPUT VOLTAGE</b>						
V <sub>sst-by</sub>	Stand-by Output Voltage		4.75	5	5.25	V
ΔV <sub>line</sub>	Line Regulation	11V < V <sub>S</sub> < 16V		5	50	mV
ΔV <sub>load</sub>	Load Regulation	5mA < I <sub>out</sub> < 100mA		12	100	mV
V <sub>dropout</sub>	Dropout Voltage	I <sub>out</sub> = 100mA, V <sub>S</sub> = 5.5V		0.2	0.6	V
I <sub>qst-by</sub>	Quiescent Current @ Stand-by	I <sub>load</sub> = 5mA		0.3	0.65	mA
<b>5V/1000mA SWITCHED OUTPUT VOLTAGE</b>						
V <sub>out5</sub>	5V Output Voltage	no load	4.75	5	5.25	V
ΔV <sub>line</sub>	Line Regulation	7V < V <sub>S</sub> < 18V		5	50	mV
ΔV <sub>load</sub>	Load Regulation	5mA < I <sub>out</sub> < 1A		12	50	mV
V <sub>dropout</sub>	Dropout Voltage	I <sub>out</sub> = 1A, V <sub>S</sub> = 5.5V		1	1.5	V
I <sub>q</sub>	Quiescent Current	75mA < I <sub>out</sub> < 1A		30	100	mA
I <sub>lim</sub>	Current Limit	Output Shorted to GND	1	1.3		A
SWon	Switch ON		3.5			V
SW off	Switch OFF				1.5	V
SW hyst	Switch Hysteresis		100	200	350	mV
R <sub>in</sub>	Input Impedance		10	40		KΩ
<b>9.2V/500mA SWITCHED OUTPUT VOLTAGE</b>						
V <sub>out9.2</sub>	9.2V Output Voltage	no load		9.2±5%		V
ΔV <sub>line</sub>	Line Regulation	11V < V <sub>S</sub> < 18V		5	50	mV
ΔV <sub>load</sub>	Load Regulation	5mA < I <sub>out</sub> < 500mA		12	50	mV
V <sub>dropout</sub>	Dropout Voltage	5.5V < V <sub>in</sub> < 9.2V, I <sub>out</sub> = 500mA		0.4	0.9	V
I <sub>q</sub>	Quiescent Current	50mA < I <sub>out</sub> < 500mA		10	25	mA
I <sub>lim</sub>	Current Limit	Output Shorted to GND	500	600		mA
SVR	Supply Voltage Rejection	f = 3KHz	45	75		dB
SWon	Switch ON		3.5			V
SW off	Switch OFF				1.5	V
SW hyst	Switch Hysteresis		100	200	500	mV
R <sub>in</sub>	Input Impedance		10	40		KΩ
<b>HIGH SIDE DRIVER WITH CLAMPED OUTPUT (16V)</b>						
V <sub>out16</sub>	Max. Output Voltage	V <sub>S</sub> = 18V	14.6		16.2	V
I <sub>O</sub>	Output Continuous Current	V <sub>S</sub> = 16V	2			A
V <sub>dropout</sub>	Dropout Voltage	5V < V <sub>in</sub> < 15V, I <sub>out</sub> = 2A		0.5	1	V
SWon	Switch ON		3.5			V
SW off	Switch OFF				1.5	V
SW hyst	Switch Hysteresis		100	200	500	mV
R <sub>in</sub>	Input Impedance		10	40		KΩ

**ELECTRICAL CHARACTERISTICS** (continued)(V<sub>S</sub> = 14V, T<sub>amb</sub> = 25°C, unless otherwise specified.)

Symbol	Parameter	Test Condition	Min.	Typ.	Max.	Unit
<b>FAULT</b>						
TH <sub>fault</sub>	Fault Threshold		7		8.5	V
HYST <sub>fault</sub>	Fault Threshold Hysteresis		100	200	400	mV
OUT <sub>fault</sub>	Fault Output Voltage				1.5	V
I <sub>leak</sub>	Fault Leakage Current				50	μA
<b>RESET</b>						
THON <sub>reset</sub>	Reset ON Threshold	MIN @ V <sub>MEM</sub> = 4.75V MAX @ V <sub>MEM</sub> = 5.25V	0.938		0.97	Vst-by
THOFF <sub>reset</sub>	Reset OFF Threshold		0.97		0.99	Vst-by
HYST <sub>reset</sub>	Reset Threshold Hysteresis		75	175	300	mV
OUT <sub>reset</sub>	Reset Output Voltage	I <sub>LOAD</sub> = 2mA			1.5	V
I <sub>leak</sub>	Reset Leakage Current				50	μA
<b>IGNITION</b>						
TH <sub>ign</sub>	Ign Comparator Positive Threshold		5.5	6	7.5	V
HYST <sub>ign</sub>	Ign Comparator Threshold Hysteresis		100	300	500	mV
IGN <sub>high</sub>	Ignition Comparator Output High		3.5		Vst-by	V
IGN <sub>low</sub>	Ignition Comparator Output Low		-0.5		1.5	V

DIM.	mm			inch		
	MIN.	TYP.	MAX.	MIN.	TYP.	MAX.
A5						0.197
B			2.65			0.104
C			1.6			0.063
D		1			0.039	
E	0.49		0.55	0.019		0.022
F	0.66		0.75	0.026		0.030
G	1.02	1.27	1.52	0.040	0.050	0.060
G1	17.53	17.78	18.03	0.690	0.700	0.710
H1	19.6			0.772		
H2			20.2			0.795
L	21.9	22.2	22.5	0.862	0.874	0.886
L1	21.7	22.1	22.5	0.854	0.87	0.886
L2	17.65		18.1	0.695		0.713
L3	17.25	17.5	17.75	0.679	0.689	0.699
L4	10.3	10.7	10.9	0.406	0.421	0.429
L7	2.65		2.9	0.104		0.114
M	4.25	4.55	4.85	0.167	0.179	0.191
M1	4.73	5.08	5.43	0.186	0.200	0.214
S	1.9		2.6	0.075		0.102
S1	1.9		2.6	0.075		0.102
Dia1	3.65		3.85	0.144		0.152

## OUTLINE AND MECHANICAL DATA

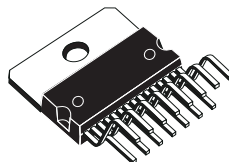

## Multiwatt15 (Vertical)

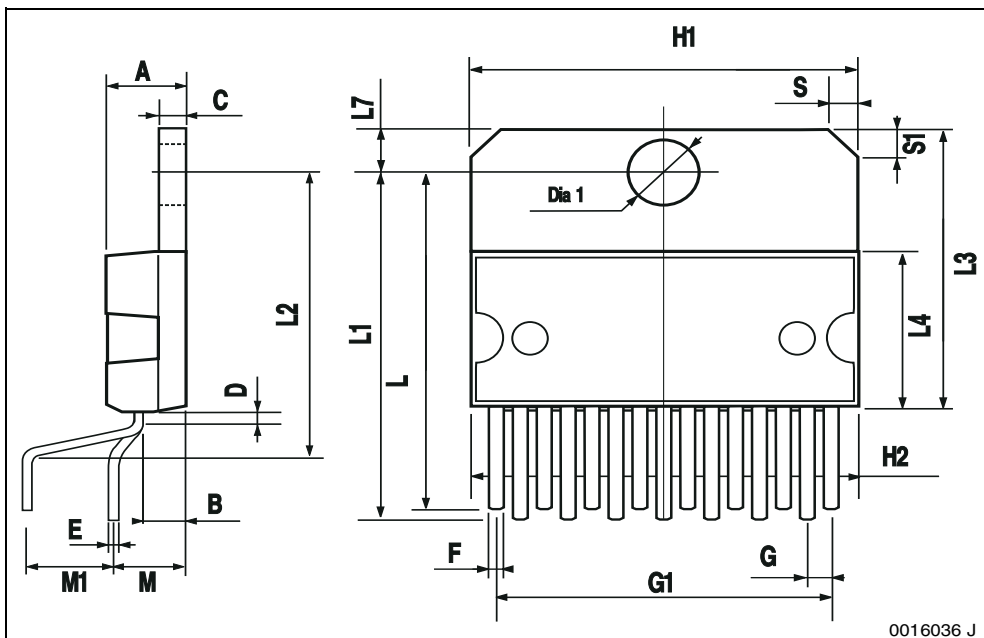

0016036 J

**Please Read Carefully:**

Information in this document is provided solely in connection with ST products. STMicroelectronics NV and its subsidiaries ("ST") reserve the right to make changes, corrections, modifications or improvements, to this document, and the products and services described herein at any time, without notice.

All ST products are sold pursuant to ST's terms and conditions of sale.

Purchasers are solely responsible for the choice, selection and use of the ST products and services described herein, and ST assumes no liability whatsoever relating to the choice, selection or use of the ST products and services described herein.

No license, express or implied, by estoppel or otherwise, to any intellectual property rights is granted under this document. If any part of this document refers to any third party products or services it shall not be deemed a license grant by ST for the use of such third party products or services, or any intellectual property contained therein or considered as a warranty covering the use in any manner whatsoever of such third party products or services or any intellectual property contained therein.

**UNLESS OTHERWISE SET FORTH IN ST'S TERMS AND CONDITIONS OF SALE ST DISCLAIMS ANY EXPRESS OR IMPLIED WARRANTY WITH RESPECT TO THE USE AND/OR SALE OF ST PRODUCTS INCLUDING WITHOUT LIMITATION IMPLIED WARRANTIES OF MERCHANTABILITY, FITNESS FOR A PARTICULAR PURPOSE (AND THEIR EQUIVALENTS UNDER THE LAWS OF ANY JURISDICTION), OR INFRINGEMENT OF ANY PATENT, COPYRIGHT OR OTHER INTELLECTUAL PROPERTY RIGHT.**

**ST PRODUCTS ARE NOT DESIGNED OR AUTHORIZED FOR USE IN: (A) SAFETY CRITICAL APPLICATIONS SUCH AS LIFE SUPPORTING, ACTIVE IMPLANTED DEVICES OR SYSTEMS WITH PRODUCT FUNCTIONAL SAFETY REQUIREMENTS; (B) AERONAUTIC APPLICATIONS; (C) AUTOMOTIVE APPLICATIONS OR ENVIRONMENTS, AND/OR (D) AEROSPACE APPLICATIONS OR ENVIRONMENTS. WHERE ST PRODUCTS ARE NOT DESIGNED FOR SUCH USE, THE PURCHASER SHALL USE PRODUCTS AT PURCHASER'S SOLE RISK, EVEN IF ST HAS BEEN INFORMED IN WRITING OF SUCH USAGE, UNLESS A PRODUCT IS EXPRESSLY DESIGNATED BY ST AS BEING INTENDED FOR "AUTOMOTIVE, AUTOMOTIVE SAFETY OR MEDICAL" INDUSTRY DOMAINS ACCORDING TO ST PRODUCT DESIGN SPECIFICATIONS. PRODUCTS FORMALLY ESCC, QML OR JAN QUALIFIED ARE DEEMED SUITABLE FOR USE IN AEROSPACE BY THE CORRESPONDING GOVERNMENTAL AGENCY.**

Resale of ST products with provisions different from the statements and/or technical features set forth in this document shall immediately void any warranty granted by ST for the ST product or service described herein and shall not create or extend in any manner whatsoever, any liability of ST.

ST and the ST logo are trademarks or registered trademarks of ST in various countries.  
Information in this document supersedes and replaces all information previously supplied.

The ST logo is a registered trademark of STMicroelectronics. All other names are the property of their respective owners.

© 2013 STMicroelectronics - All rights reserved



STMicroelectronics group of companies

Australia - Belgium - Brazil - Canada - China - Czech Republic - Finland - France - Germany - Hong Kong - India - Israel - Italy - Japan - Malaysia - Malta - Morocco - Philippines - Singapore - Spain - Sweden - Switzerland - United Kingdom - United States of America







[www.st.com](http://www.st.com)

# Looking for pricing, stock, or lifecycle information?

Click below to explore more details on WIN SOURCE:

-  [View L4953G on WIN SOURCE](#)
-  [STMicroelectronics Information](#)

## Optimize Your Supply Chain with WIN SOURCE Solutions

-  Global Sourcing Solution
-  Obsolete Management
-  Cost Control Management
-  Shortage Management
-  Alternative Solution
-  Excess Inventory Management