



**THE DATASHEET OF  
L4989D013TR**



## Automotive low power voltage regulator

Datasheet - production data

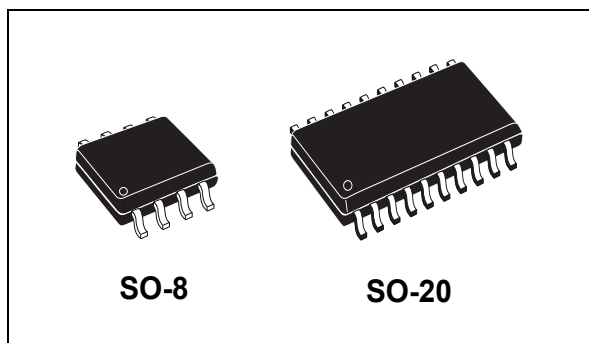

### Features

- AEC-Q100 qualified 
- Operating DC supply voltage range 5.6 V to 31 V
- Very low quiescent current with watchdog disabled
- Precision output voltage ( $\pm 3\%$ )
- Low drop voltage (180 mV typ at  $I_o = 150$  mA)
- Reset circuit sensing the output voltage down to 1 V
- Programmable reset delay with external capacitor
- Watchdog disable input
- Programmable watchdog timer with external capacitor
- Thermal shutdown and short circuit protection
- Wide temperature range ( $T_j = -40^\circ\text{C}$  to  $150^\circ\text{C}$ )

### Description

The L4989M and L4989MD are monolithic integrated 5 V voltage regulators with a low drop voltage at currents up to 150 mA.

The output voltage regulating element consists in a p-channel MOS and the regulation is performed regardless of input voltage transients up to 40 V. The high precision of the output voltage is obtained with a pre-trimmed reference voltage.

The devices are protected against short circuit and an overtemperature protection switches off the devices in case of extremely high power dissipation.

The L4989M and L4989MD watchdogs are active when the Enable pin is high. Features like reset and watchdog make this devices particularly suitable to supply microprocessor systems in automotive applications.

Table 1. Device summary

Package	Order codes	
	Tube	Tape & reel
SO-8	L4989D	L4989D013TR
SO-20	L4989MD	L4989MD013TR

# Contents

- 1      Block diagram and pin configuration ..... 5**
  
- 2      Electrical specifications ..... 7**
  - 2.1 Absolute maximum ratings ..... 7
  - 2.2 Thermal data ..... 7
  - 2.3 Electrical characteristics ..... 8
  
- 3      Application information ..... 11**
  - 3.1 Voltage regulator .....11
  - 3.2 Reset .....11
  - 3.3 Watchdog ..... 12
  
- 4      Package and packing information ..... 13**
  - 4.1 ECOPACK<sup>®</sup> packages ..... 13
  - 4.2 SO-8 package information ..... 13
  - 4.3 SO-20 package information ..... 15
  - 4.4 SO-8 packing information ..... 16
  - 4.5 SO-20 packing information ..... 17
  
- 5      Revision history ..... 18**

## List of tables

Table 1.	Device summary . . . . .	1
Table 2.	Pins description . . . . .	5
Table 3.	Absolute maximum ratings . . . . .	7
Table 4.	Thermal data . . . . .	7
Table 5.	General . . . . .	8
Table 6.	Reset . . . . .	9
Table 7.	Watchdog . . . . .	9
Table 8.	Watchdog Enable . . . . .	10
Table 9.	SO-8 mechanical data . . . . .	14
Table 10.	SO-20 mechanical data . . . . .	15
Table 11.	Document revision history . . . . .	18

## List of figures

Figure 1.	Block diagram . . . . .	5
Figure 2.	Pins configuration (top view). . . . .	6
Figure 3.	Behavior of output current versus regulated voltage $V_o$ . . . . .	11
Figure 4.	Reset timing diagram . . . . .	12
Figure 5.	Watchdog timing diagram . . . . .	12
Figure 6.	SO-8 package dimensions . . . . .	13
Figure 7.	SO-20 package dimensions . . . . .	15
Figure 8.	SO-8 tube shipment (no suffix) . . . . .	16
Figure 9.	SO-8 tape and reel shipment (suffix "TR") . . . . .	16
Figure 10.	SO-20 tube shipment (no suffix) . . . . .	17
Figure 11.	SO-20 tape and reel shipment (suffix "TR") . . . . .	17

# 1 Block diagram and pin configuration

Figure 1. Block diagram

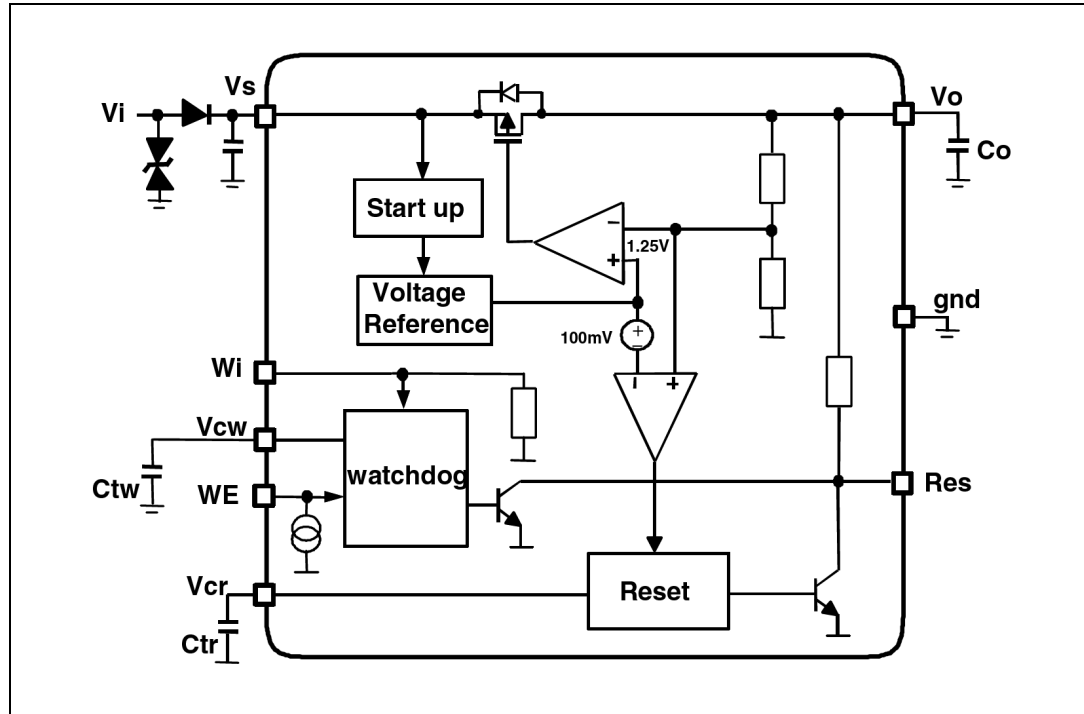

Table 2. Pins description

Pin name	SO-8(D)	S0-20(MD)	Function
WE <sub>n</sub>	1	1	Watchdog Enable input If high watchdog functionality is active.
Gnd	2	4	Ground reference
Gnd		5, 6, 15, 16	Ground. Connected these pins to a heat spreader ground
Res	3	7	Reset output. It is pulled down when output voltage goes below V <sub>o_th</sub> or frequency at Wi is too low.
Vcr	4	10	Reset timing adjust. A capacitor between Vcr pin and gnd, sets the reset delay time (t <sub>rd</sub> )
Vcw	5	11	Watchdog timer adjust A capacitor between Vcw pin and gnd, sets the time response of the watchdog monitor.
Wi	6	14	Watchdog input. If the frequency at this input pin is too low, the Reset output is activated.

Table 2. Pins description (continued)

Pin name	SO-8(D)	SO-20(MD)	Function
V <sub>o</sub>	7	17	Voltage regulator output Block to ground with a capacitor >100 nF (needed for regulator stability)
V <sub>S</sub>	8	20	Supply voltage Block to ground directly at IC pin with a capacitor
N.C.		2, 3, 8, 9, 12, 13, 18, 19	Not connected

Figure 2. Pins configuration (top view)

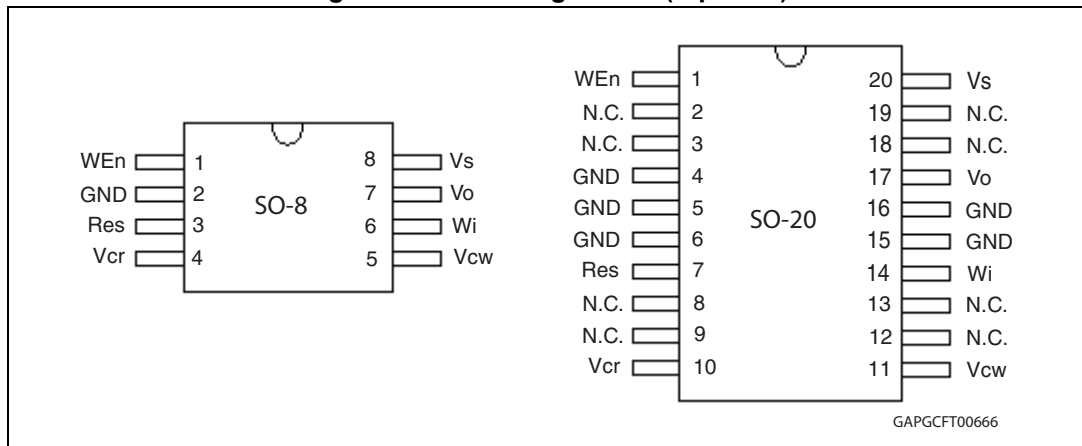

## 2 Electrical specifications

### 2.1 Absolute maximum ratings

Table 3. Absolute maximum ratings

Symbol	Parameter	Value	Unit
$V_{VSDC}$	DC supply voltage	-0.3 to 40	V
$I_{VSDC}$	Input current	Internally limited	
$V_{Vo}$	DC output voltage	-0.3 to 6	V
$I_{Vo}$	DC output current	Internally limited	
$V_{Wi}$	Watchdog input voltage	-0.3 to $V_{Vo} + 0.3$	V
$V_{Od}$	Open Drain output voltage	-0.3 to $V_{Vo} + 0.3$	V
$I_{Od}$	Open Drain output current	Internally limited	
$V_{Cr}$	Reset delay voltage	-0.3 to $V_{Vo} + 0.3$	V
$V_{Cw}$	Watchdog delay voltage	-0.3 to $V_{Vo} + 0.3$	V
$V_{WEn}$	Watchdog Enable input voltage	-0.3 to 40	V
$T_j$	Junction temperature	-40 to 150	°C
$V_{ESD}$	ESD voltage level (HBM-MIL STD 883C)	±2	kV

Note: Maximum ratings are absolute ratings; exceeding any one of these values may cause permanent damage to the integrated circuit.

### 2.2 Thermal data

Table 4. Thermal data

Symbol	Parameter	S0-8	S0-12+4+4	Unit
$R_{th-jamb}$	Thermal resistance junction to ambient	130 to 180	50 <sup>(1)</sup>	°C/W

1. With 6 sq. cm on board heat sink.

## 2.3 Electrical characteristics

$V_S = 5.6 \text{ V to } 31 \text{ V}$ ,  $T_j = -40^\circ\text{C to } +150^\circ\text{C}$  unless otherwise specified.

Table 5. General

Pin	Symbol	Parameter	Test condition	Min.	Typ.	Max.	Unit
$V_o$	$V_{o\_ref}$	Output voltage	$V_S = 5.6 \text{ to } 31 \text{ V}$ ; $I_o = 1 \text{ to } 150 \text{ mA}$	4.85	5.0	5.15	V
$V_o$	$I_{short\_13}$	Short circuit current	$V_S = 13.5 \text{ V}^{(1)}$	160	210	250	mA
$V_o$	$I_{lim}$	Output current limitation	$V_S = 13.5 \text{ V}^{(1)}$	170	250	290	mA
$V_S, V_o$	$V_{line}$	Line regulation voltage	$V_S = 5.6 \text{ to } 31 \text{ V}$ ; $I_o = 1 \text{ to } 150 \text{ mA}$			25	mV
$V_o$	$V_{load}$	Load regulation voltage	$I_o = 1 \text{ to } 150 \text{ mA}$			25	mV
$V_S, V_o$	$V_{dp}$	Drop voltage	$I_o = 150 \text{ mA}$		180	400	mV
$V_S, V_o$	SVR	Ripple rejection	$f_r = 100 \text{ Hz}$	55			dB
$V_S, V_o$	$I_{qs\_1}$	Current consumption with watchdog not active $I_{qs\_1} = I_{VS} - I_o$	$V_S = 13.5 \text{ V}$ ; $I_o < 1 \text{ mA}$ ; $WE_n = \text{low}$		69	115	$\mu\text{A}$
$V_S, V_o$	$I_{qs\_10}$	Current consumption with watchdog not active $I_{qs\_10} = I_{VS} - I_o$	$V_S = 13.5 \text{ V}$ ; $I_o = 10 \text{ mA}$ ; $WE_n = \text{low}$		127	300	$\mu\text{A}$
$V_S, V_o$	$I_{qs\_50}$	Current consumption with watchdog not active $I_{qs\_50} = I_{VS} - I_o$	$V_S = 13.5 \text{ V}$ ; $I_o = 50 \text{ mA}$ ; $WE_n = \text{low}$		498	900	$\mu\text{A}$
$V_S, V_o$	$I_{qs\_150}$	Current consumption with watchdog not active $I_{qs\_150} = I_{VS} - I_o$	$V_S = 13.5 \text{ V}$ ; $I_o = 150 \text{ mA}$ ; $WE_n = \text{low}$		1.40	2	mA
$V_S, V_o$	$I_{qn\_1}$	Current consumption with watchdog active $I_{qn\_1} = I_{VS} - I_o$	$V_S = 13.5 \text{ V}$ ; $I_o < 1 \text{ mA}$ ; $WE_n = \text{high}$		110	170	$\mu\text{A}$
$V_S, V_o$	$I_{qn\_10}$	Current consumption with watchdog active $I_{qn\_10} = I_{VS} - I_o$	$V_S = 13.5 \text{ V}$ ; $I_o = 10 \text{ mA}$ ; $WE_n = \text{high}$		168	350	$\mu\text{A}$
$V_S, V_o$	$I_{qn\_50}$	Current consumption with watchdog active $I_{qn\_50} = I_{VS} - I_o$	$V_S = 13.5 \text{ V}$ ; $I_o = 50 \text{ mA}$ ; $WE_n = \text{high}$		538	1000	$\mu\text{A}$
$V_S, V_o$	$I_{qn\_150}$	Current consumption with watchdog active $I_{qn\_150} = I_{VS} - I_o$	$V_S = 13.5 \text{ V}$ ; $I_o = 150 \text{ mA}$ ; $WE_n = \text{high}$		1.45	2	mA
	$T_w$	Thermal protection temperature		150		190	$^\circ\text{C}$
	$T_w\_hy$	Thermal protection temperature hysteresis			10		$^\circ\text{C}$

1. See [Figure 3](#).

Table 6. Reset

Pin	Symbol	Parameter	Test condition	Min.	Typ.	Max.	Unit
Res	Vres_l	Reset output low voltage	$R_{\text{ext}} = 5 \text{ k}\Omega$ to $V_0$ ; $V_0 > 1 \text{ V}$			0.4	V
Res	$I_{\text{Res\_lkg}}$	Reset output high leakage current	$V_{\text{Res}} = 5 \text{ V}$			1	$\mu\text{A}$
Res	$R_{\text{Res}}$	Pull up internal resistance	Versus $V_0$	10	20	50	$\text{k}\Omega$
Res	$V_{\text{o\_th}}$	Reset threshold voltage	$V_{\text{S}} = 5.6$ to $31 \text{ V}$ ; $I_0 = 1$ to $150 \text{ mA}$	6%	8%	10%	Below $V_{\text{o\_ref}}$
Vcr	$V_{\text{rth}}$	Reset timing low threshold	$V_{\text{S}} = 13.5 \text{ V}$	10%	13%	16%	$V_{\text{o\_ref}}$
Vcr	$V_{\text{rthh}}$	Reset timing high threshold	$V_{\text{S}} = 13.5 \text{ V}$	44%	47%	50%	$V_{\text{o\_ref}}$
Vcr	$I_{\text{cr}}$	Charge current	$V_{\text{S}} = 13.5 \text{ V}$	8	15	30	$\mu\text{A}$
Vcr	$I_{\text{dr}}$	Discharge current	$V_{\text{S}} = 13.5 \text{ V}$	8	15	30	$\mu\text{A}$
Res	$T_{\text{rr\_2}}$	Reset reaction time <sup>(1)</sup>	$V_0 = V_{\text{o\_th}} - 100 \text{ mV}$	100	250	700	$\mu\text{s}$
Res	$T_{\text{rd}}$	Reset delay time	$V_{\text{S}} = 13.5 \text{ V}$ ; $C_{\text{tr}} = 1 \text{ nF}$	65	115	165	ms

1. When  $V_0$  becomes lower than 4 V, the reset reaction time decreases down to 2  $\mu\text{s}$  assuring a faster reset condition in this particular case.

Table 7. Watchdog

Pin	Symbol	Parameter	Test condition	Min.	Typ.	Max.	Unit
Wi	Vih	Input high voltage	$V_{\text{S}} = 13.5 \text{ V}$	3.5			V
Wi	Vil	Input low voltage	$V_{\text{S}} = 13.5 \text{ V}$			1.5	V
Wi	Vih	Input hysteresis	$V_{\text{S}} = 13.5 \text{ V}$		500		mV
Wi	Rwi	Pull down resistor	$V_{\text{S}} = 13.5 \text{ V}$	30	100	250	$\text{k}\Omega$
Vcw	Vwhth	High threshold	$V_{\text{S}} = 13.5 \text{ V}$	44%	47%	50%	$V_{\text{o\_ref}}$
Vcw	Vwlth	Low threshold	$V_{\text{S}} = 13.5 \text{ V}$	10%	13%	16%	$V_{\text{o\_ref}}$
Vcw	Icwc	Charge current	$V_{\text{S}} = 13.5 \text{ V}$ ; $V_{\text{cw}} = 0.1 \text{ V}$	5	10	20	$\mu\text{A}$
Vcw	Icwd	Discharge current	$V_{\text{S}} = 13.5 \text{ V}$ ; $V_{\text{cw}} = 2.5 \text{ V}$	1.25	2.5	5	$\mu\text{A}$
Vcw	Twop	Watchdog period	$V_{\text{S}} = 13.5 \text{ V}$ ; $C_{\text{tw}} = 47 \text{ nF}$	20	40	80	ms
Res	twol	Watchdog output low time	$V_{\text{S}} = 13.5 \text{ V}$ ; $C_{\text{tw}} = 47 \text{ nF}$	4	8	16	ms

Table 8. Watchdog Enable

Pin	Symbol	Parameter	Test condition	Min.	Typ.	Max.	Unit
WE <sub>n</sub>	V <sub>WE<sub>n</sub>_l</sub>	Enable input low voltage				1	V
WE <sub>n</sub>	V <sub>WE<sub>n</sub>_h</sub>	Enable input high voltage		3			V
WE <sub>n</sub>	V <sub>WE<sub>n</sub>_hy</sub>	Enable input hysteresis		600	920	1300	mV
WE <sub>n</sub>	I <sub>_leak</sub>	Pull down current	V <sub>S</sub> = 13.5 V	1	2.5	5	μA

## 3 Application information

### 3.1 Voltage regulator

The voltage regulator uses a p-channel MOS transistor as a regulating element. With this structure a very low dropout voltage at current up to 150 mA is obtained. The output voltage is regulated up to transient input supply voltage of 40 V. No functional interruption due to over-voltage pulses is generated. The voltage Regulator is always active and not depending on the state of WE<sub>n</sub> input pin. A short circuit protection to GND is provided.

**Figure 3. Behavior of output current versus regulated voltage V<sub>o</sub>**

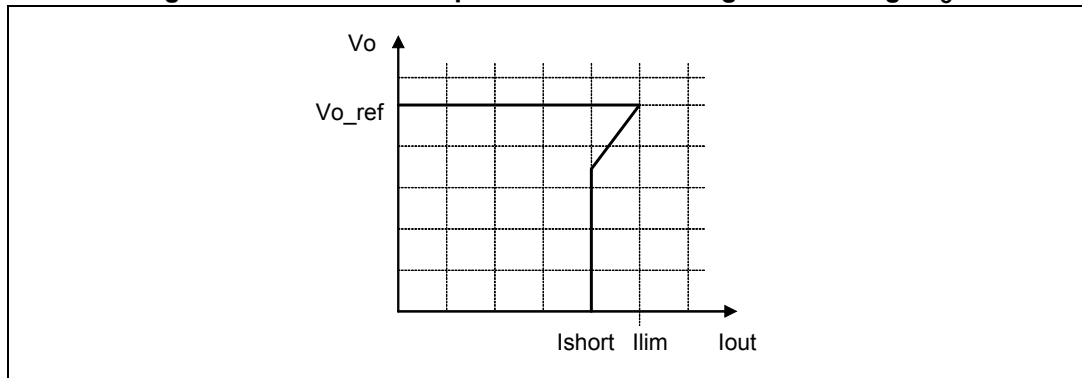

### 3.2 Reset

The reset circuit supervises the output voltage V<sub>o</sub>. The V<sub>o\_th</sub> reset threshold is defined with the internal reference voltage and a resistor output divider. If the output voltage becomes lower than V<sub>o\_th</sub> then Res goes low with a reaction time t<sub>rr</sub>. The reset low signal is guaranteed for an output voltage V<sub>o</sub> greater than 1 V.

When the output voltage becomes higher than V<sub>o\_th</sub> then Res goes high with a delay t<sub>rd</sub>. This delay is obtained by an internal oscillator.

The oscillator period is given by:

$$T_{osc} = [(V_{rth} - V_{rlth}) \times C_{tr}] / I_{cr} + [(V_{rth} - V_{rlth}) \times C_{tr}] / I_{dr}$$

where:

- I<sub>cr</sub>: is an internally generated charge current
- I<sub>dr</sub>: is an internally generated discharge current
- V<sub>rth</sub>, V<sub>rlth</sub>: are two voltages defined with the output voltage and a resistor output divider
- C<sub>tr</sub>: is an external capacitance.

t<sub>rd</sub> is given by:

$$t_{rd} = 512 \times T_{osc}$$

The Reset is always active and not depending on the state of WE<sub>n</sub> input pin.

Figure 4. Reset timing diagram

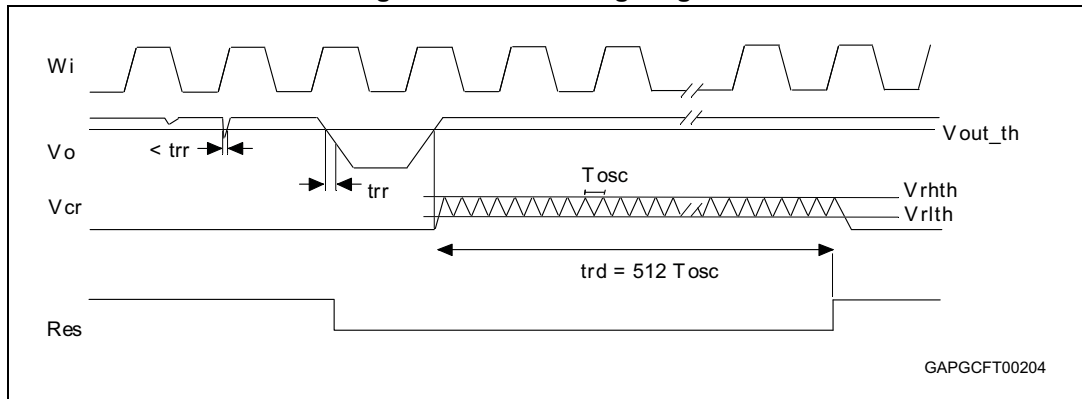

### 3.3 Watchdog

A connected microcontroller is monitored by the watchdog input  $W_i$ . If pulses are missing, the Reset output pin is set to low. The pulse sequence time can be set within a wide range with the external capacitor,  $C_{tw}$ . The watchdog circuit discharges the capacitor  $C_{tw}$  with the constant current  $I_{cwd}$ . If the lower threshold  $V_{wlt}$  is reached, a watchdog reset is generated. To prevent this the microcontroller must generate a positive edge during the discharge of the capacitor before the voltage has reached the threshold  $V_{wlt}$ . In order to calculate the minimum time  $t$ , during which the micro-controller must output the positive edge, the following equation can be used:

$$(V_{whth} - V_{wlt}) \times C_{tw} = I_{cwd} \times t$$

Every  $W_i$  positive edge switches the current source from discharging to charging. The same happens when the lower threshold is reached. When the voltage reaches the upper threshold,  $V_{whth}$ , the current switches from charging to discharging. The result is a saw-tooth voltage at the watchdog timer capacitor  $C_{tw}$ .

Figure 5. Watchdog timing diagram

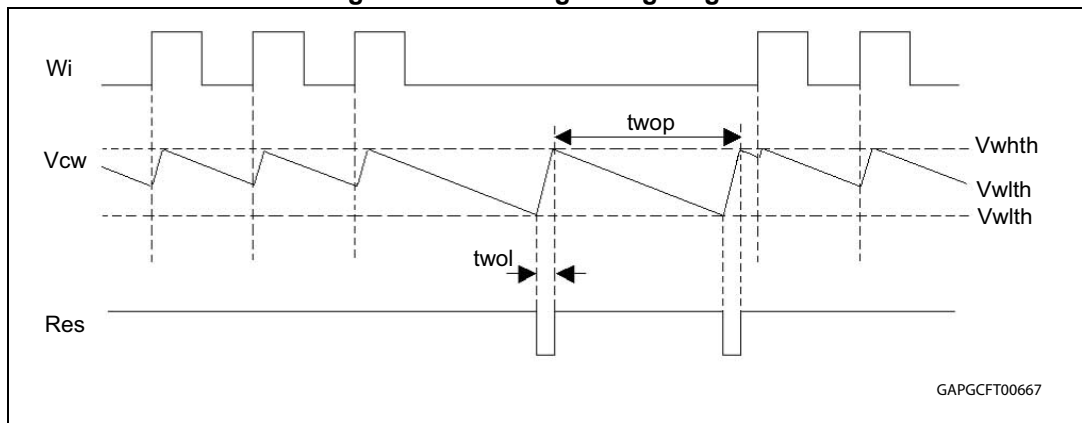

## 4 Package and packing information

### 4.1 ECOPACK<sup>®</sup> packages

In order to meet environmental requirements, ST offers these devices in different grades of ECOPACK<sup>®</sup> packages, depending on their level of environmental compliance. ECOPACK<sup>®</sup> specifications, grade definitions and product status are available at: [www.st.com](http://www.st.com). ECOPACK<sup>®</sup> is an ST trademark.

### 4.2 SO-8 package information

Figure 6. SO-8 package dimensions

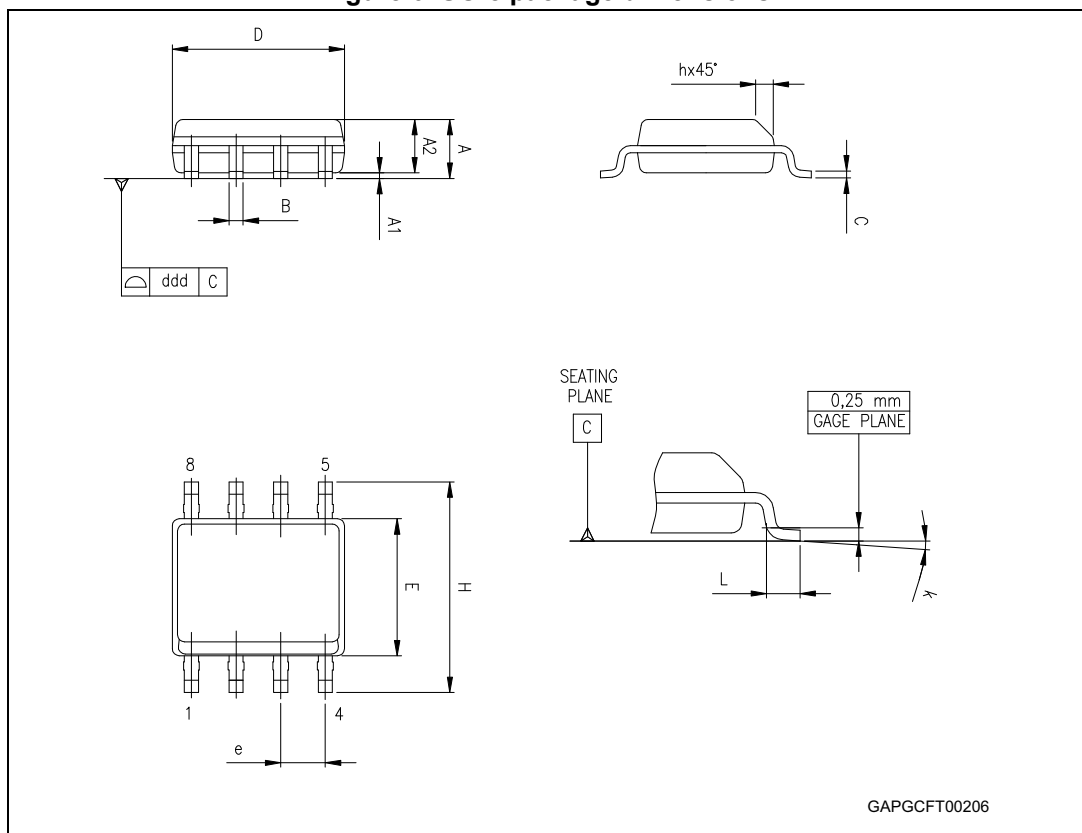

Table 9. SO-8 mechanical data

Symbol	Millimeters		
	Min.	Typ.	Max.
A			1.75
A1	0.10		0.25
A2	1.25		
b	0.28		0.48
c	0.17		0.23
D <sup>(1)</sup>	4.80	4.90	5.00
E	5.80	6.00	6.20
E1 <sup>(2)</sup>	3.80	3.90	4.00
e		1.27	
h	0.25		0.50
L	0.40		1.27
L1		1.04	
k	0°		8°
ccc			0.10

1. Dimensions D does not include mold flash, protrusions or gate burrs. Mold flash, protrusions or gate burrs shall not exceed 0.15 mm in total (both side).
2. Dimension "E1" does not include interlead flash or protrusions. Interlead flash or protrusions shall not exceed 0.25 mm per side.

### 4.3 SO-20 package information

Figure 7. SO-20 package dimensions

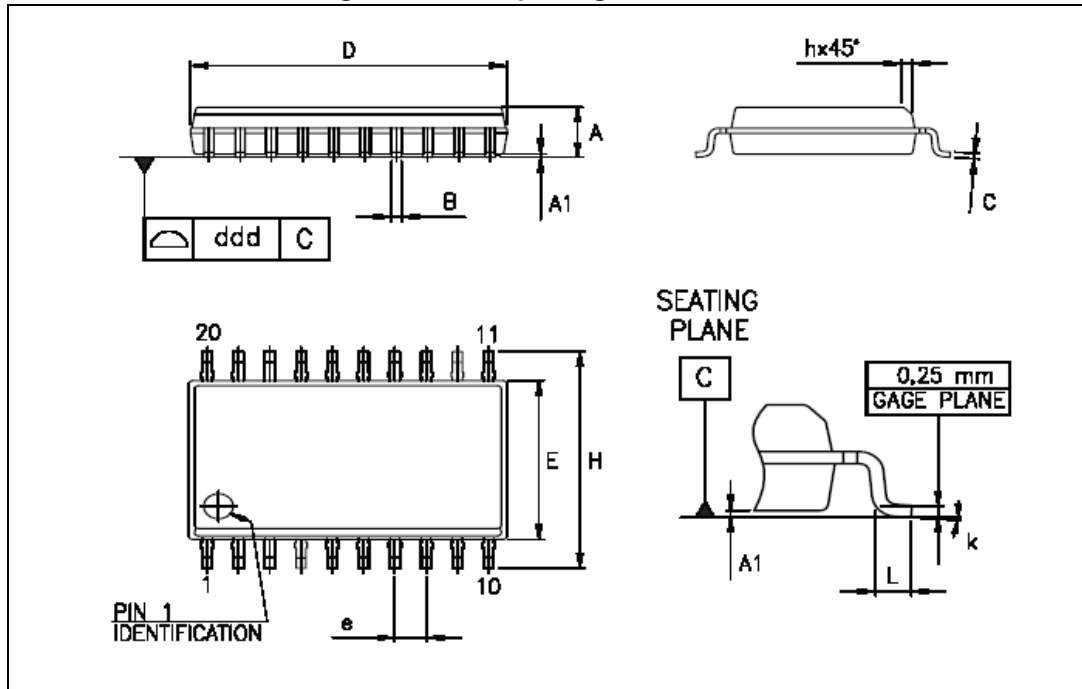

Table 10. SO-20 mechanical data

Symbol	Millimeters		
	Min.	Typ.	Max.
A	2.35		2.65
A1	0.10		0.30
B	0.33		0.51
C	0.23		0.32
D <sup>(1)</sup>	12.60		13.00
E	7.40		7.60
e		1.27	
H	10.0		10.65
h	0.25		0.75
L	0.40		1.27
k	0°		8°
ddd			0.10

1. "D" dimension does not include mold flash, protusions or gate burrs. Mold flash, protusions or gate burrs shall not exceed 0.15 mm per side.

### 4.4 SO-8 packing information

Figure 8. SO-8 tube shipment (no suffix)

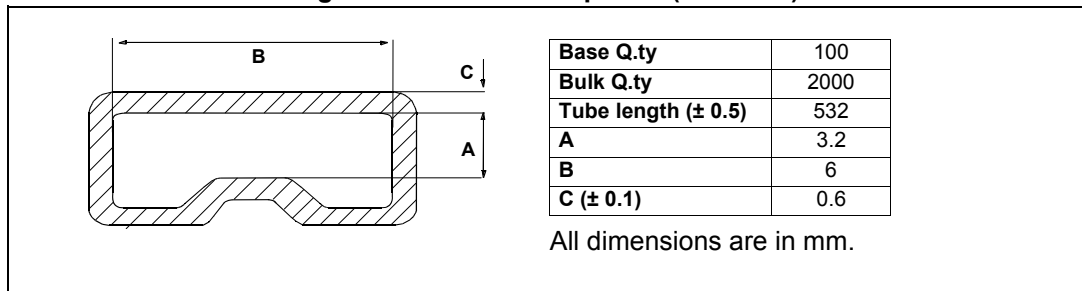
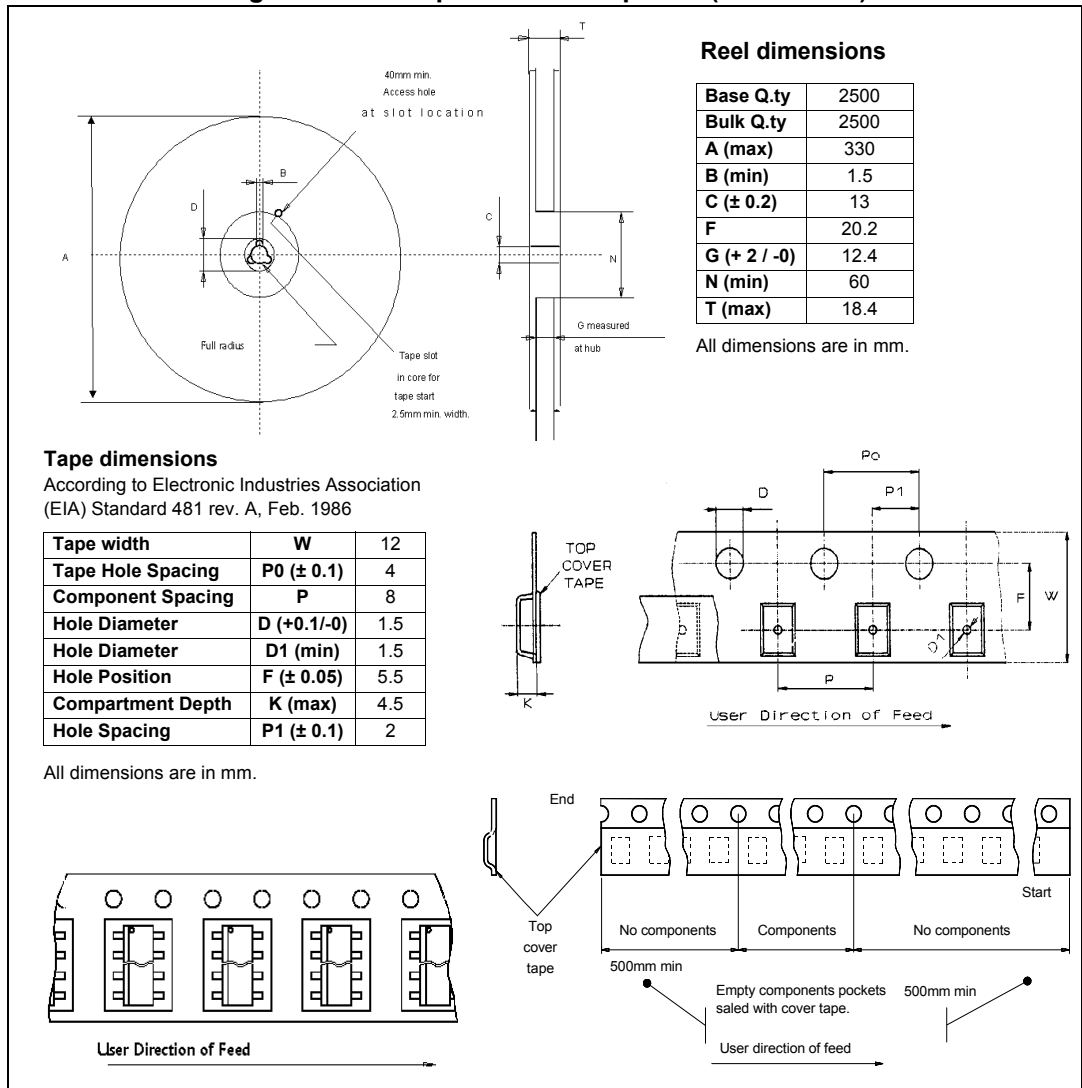

Figure 9. SO-8 tape and reel shipment (suffix "TR")



### 4.5 SO-20 packing information

Figure 10. SO-20 tube shipment (no suffix)

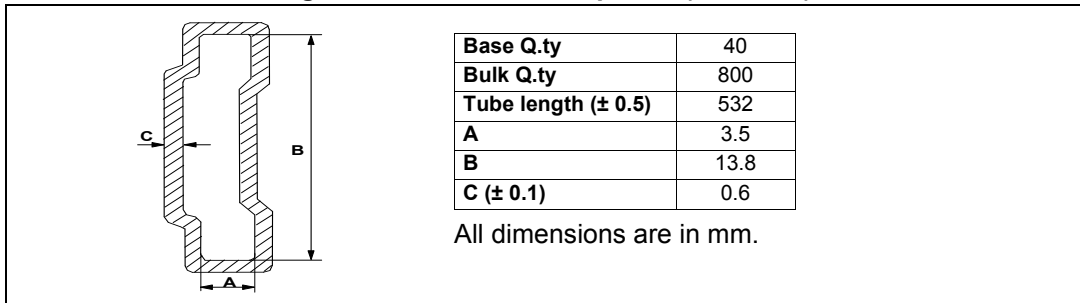
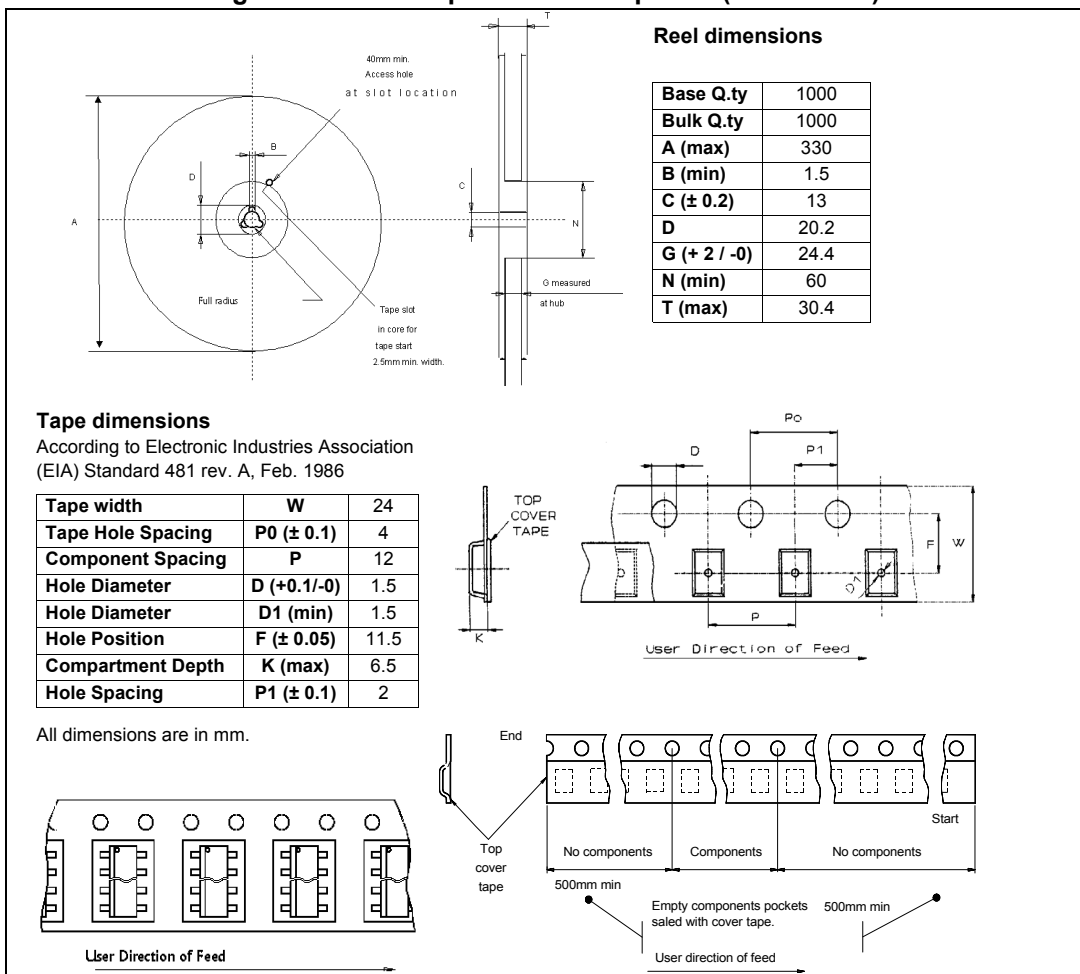

Figure 11. SO-20 tape and reel shipment (suffix "TR")



## 5 Revision history

**Table 11. Document revision history**

<b>Date</b>	<b>Revision</b>	<b>Changes</b>
16-Apr-2012	1	Initial release. This document replace the L4989 datasheet.
19-Sep-2013	2	Updated Disclaimer.
01-Oct-2018	3	Updated title and added the feature "AEC-Q100 qualified" in cover page with automotive logo.

**IMPORTANT NOTICE – PLEASE READ CAREFULLY**

STMicroelectronics NV and its subsidiaries ("ST") reserve the right to make changes, corrections, enhancements, modifications, and improvements to ST products and/or to this document at any time without notice. Purchasers should obtain the latest relevant information on ST products before placing orders. ST products are sold pursuant to ST's terms and conditions of sale in place at the time of order acknowledgement.

Purchasers are solely responsible for the choice, selection, and use of ST products and ST assumes no liability for application assistance or the design of Purchasers' products.

No license, express or implied, to any intellectual property right is granted by ST herein.

Resale of ST products with provisions different from the information set forth herein shall void any warranty granted by ST for such product.

ST and the ST logo are trademarks of ST. All other product or service names are the property of their respective owners.

Information in this document supersedes and replaces information previously supplied in any prior versions of this document.

© 2018 STMicroelectronics – All rights reserved

## Looking for pricing, stock, or lifecycle information?

Click below to explore more details on WIN SOURCE:

-  [View L4989D013TR](#) on WIN SOURCE
-  [STMicroelectronics](#) Information

## Optimize Your Supply Chain with WIN SOURCE Solutions

-  Global Sourcing Solution
-  Obsolete Management
-  Cost Control Management
-  Shortage Management
-  Alternative Solution
-  Excess Inventory Management