



**THE DATASHEET OF
L4989MD013TR**



Automotive low power voltage regulator

Datasheet - production data

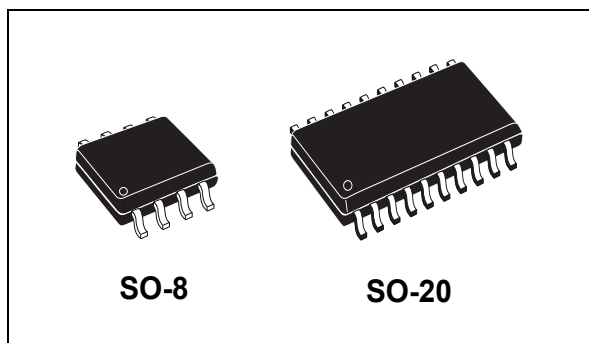

Description

The L4989M and L4989MD are monolithic integrated 5 V voltage regulators with a low drop voltage at currents up to 150 mA.

The output voltage regulating element consists in a p-channel MOS and the regulation is performed regardless of input voltage transients up to 40 V. The high precision of the output voltage is obtained with a pre-trimmed reference voltage.

The devices are protected against short circuit and an overtemperature protection switches off the devices in case of extremely high power dissipation.

The L4989M and L4989MD watchdogs are active when the Enable pin is high. Features like reset and watchdog make this devices particularly suitable to supply microprocessor systems in automotive applications.

Features

- AEC-Q100 qualified 
- Operating DC supply voltage range 5.6 V to 31 V
- Very low quiescent current with watchdog disabled
- Precision output voltage ($\pm 3\%$)
- Low drop voltage (180 mV typ at $I_o = 150$ mA)
- Reset circuit sensing the output voltage down to 1 V
- Programmable reset delay with external capacitor
- Watchdog disable input
- Programmable watchdog timer with external capacitor
- Thermal shutdown and short circuit protection
- Wide temperature range ($T_j = -40^\circ\text{C}$ to 150°C)

Table 1. Device summary

Package	Order codes	
	Tube	Tape & reel
SO-8	L4989D	L4989D013TR
SO-20	L4989MD	L4989MD013TR

Contents

- 1 Block diagram and pin configuration 5**
- 2 Electrical specifications 7**
 - 2.1 Absolute maximum ratings 7
 - 2.2 Thermal data 7
 - 2.3 Electrical characteristics 8
- 3 Application information 11**
 - 3.1 Voltage regulator11
 - 3.2 Reset11
 - 3.3 Watchdog 12
- 4 Package and packing information 13**
 - 4.1 ECOPACK® packages 13
 - 4.2 SO-8 package information 13
 - 4.3 SO-20 package information 15
 - 4.4 SO-8 packing information 16
 - 4.5 SO-20 packing information 17
- 5 Revision history 18**

List of tables

Table 1.	Device summary	1
Table 2.	Pins description	5
Table 3.	Absolute maximum ratings	7
Table 4.	Thermal data	7
Table 5.	General	8
Table 6.	Reset	9
Table 7.	Watchdog	9
Table 8.	Watchdog Enable	10
Table 9.	SO-8 mechanical data	14
Table 10.	SO-20 mechanical data	15
Table 11.	Document revision history	18

List of figures

Figure 1.	Block diagram	5
Figure 2.	Pins configuration (top view).	6
Figure 3.	Behavior of output current versus regulated voltage V_o	11
Figure 4.	Reset timing diagram	12
Figure 5.	Watchdog timing diagram	12
Figure 6.	SO-8 package dimensions	13
Figure 7.	SO-20 package dimensions	15
Figure 8.	SO-8 tube shipment (no suffix)	16
Figure 9.	SO-8 tape and reel shipment (suffix "TR")	16
Figure 10.	SO-20 tube shipment (no suffix)	17
Figure 11.	SO-20 tape and reel shipment (suffix "TR")	17

1 Block diagram and pin configuration

Figure 1. Block diagram

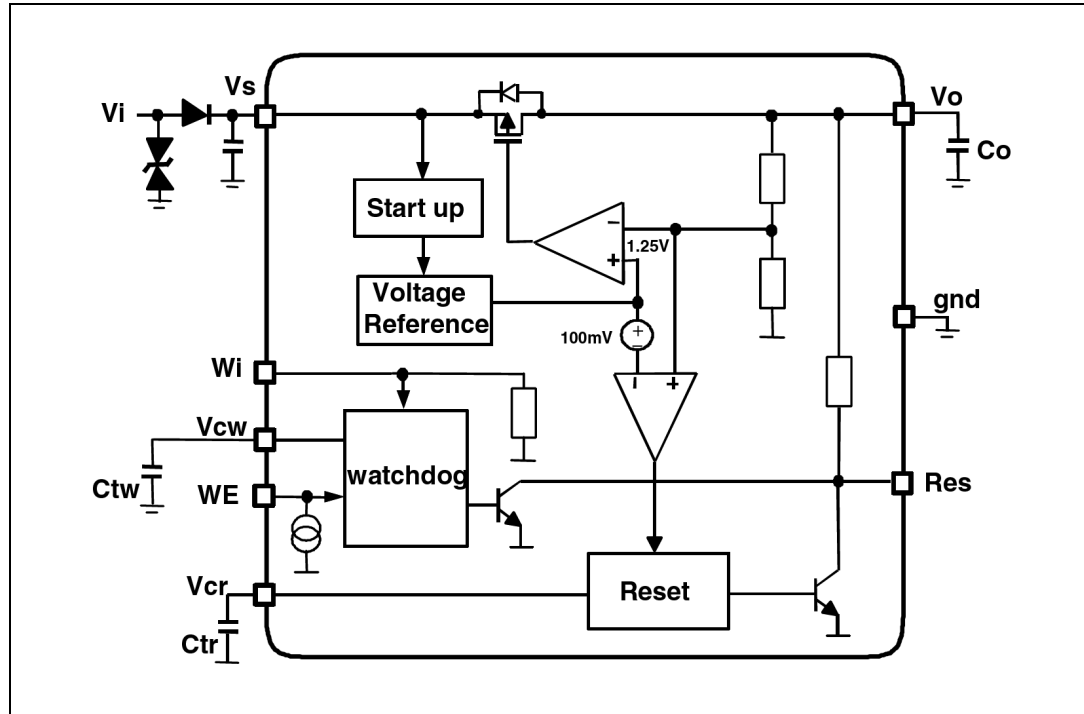

Table 2. Pins description

Pin name	SO-8(D)	S0-20(MD)	Function
WE _n	1	1	Watchdog Enable input If high watchdog functionality is active.
Gnd	2	4	Ground reference
Gnd		5, 6, 15, 16	Ground. Connected these pins to a heat spreader ground
Res	3	7	Reset output. It is pulled down when output voltage goes below V _{o_th} or frequency at Wi is too low.
Vcr	4	10	Reset timing adjust. A capacitor between Vcr pin and gnd, sets the reset delay time (t _{rd})
Vcw	5	11	Watchdog timer adjust A capacitor between Vcw pin and gnd, sets the time response of the watchdog monitor.
Wi	6	14	Watchdog input. If the frequency at this input pin is too low, the Reset output is activated.

Table 2. Pins description (continued)

Pin name	SO-8(D)	SO-20(MD)	Function
V _o	7	17	Voltage regulator output Block to ground with a capacitor >100 nF (needed for regulator stability)
V _S	8	20	Supply voltage Block to ground directly at IC pin with a capacitor
N.C.		2, 3, 8, 9, 12, 13, 18, 19	Not connected

Figure 2. Pins configuration (top view)

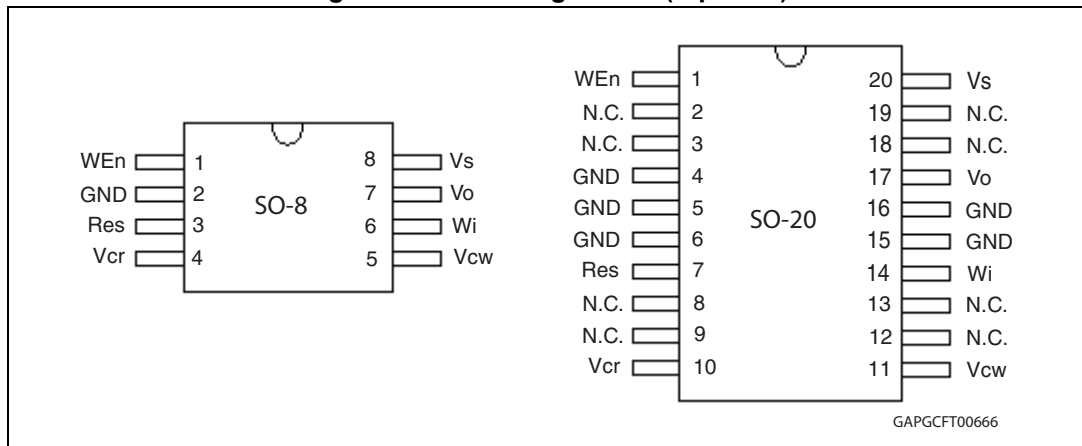

2 Electrical specifications

2.1 Absolute maximum ratings

Table 3. Absolute maximum ratings

Symbol	Parameter	Value	Unit
V_{VSDC}	DC supply voltage	-0.3 to 40	V
I_{VSDC}	Input current	Internally limited	
V_{Vo}	DC output voltage	-0.3 to 6	V
I_{Vo}	DC output current	Internally limited	
V_{Wi}	Watchdog input voltage	-0.3 to $V_{Vo} + 0.3$	V
V_{Od}	Open Drain output voltage	-0.3 to $V_{Vo} + 0.3$	V
I_{Od}	Open Drain output current	Internally limited	
V_{Cr}	Reset delay voltage	-0.3 to $V_{Vo} + 0.3$	V
V_{Cw}	Watchdog delay voltage	-0.3 to $V_{Vo} + 0.3$	V
V_{WE_n}	Watchdog Enable input voltage	-0.3 to 40	V
T_j	Junction temperature	-40 to 150	°C
V_{ESD}	ESD voltage level (HBM-MIL STD 883C)	±2	kV

Note: Maximum ratings are absolute ratings; exceeding any one of these values may cause permanent damage to the integrated circuit.

2.2 Thermal data

Table 4. Thermal data

Symbol	Parameter	S0-8	S0-12+4+4	Unit
$R_{th-jamb}$	Thermal resistance junction to ambient	130 to 180	50 ⁽¹⁾	°C/W

1. With 6 sq. cm on board heat sink.

2.3 Electrical characteristics

$V_S = 5.6 \text{ V to } 31 \text{ V}$, $T_j = -40^\circ\text{C to } +150^\circ\text{C}$ unless otherwise specified.

Table 5. General

Pin	Symbol	Parameter	Test condition	Min.	Typ.	Max.	Unit
V_o	V_{o_ref}	Output voltage	$V_S = 5.6 \text{ to } 31 \text{ V}$; $I_o = 1 \text{ to } 150 \text{ mA}$	4.85	5.0	5.15	V
V_o	I_{short_13}	Short circuit current	$V_S = 13.5 \text{ V}^{(1)}$	160	210	250	mA
V_o	I_{lim}	Output current limitation	$V_S = 13.5 \text{ V}^{(1)}$	170	250	290	mA
V_S, V_o	V_{line}	Line regulation voltage	$V_S = 5.6 \text{ to } 31 \text{ V}$; $I_o = 1 \text{ to } 150 \text{ mA}$			25	mV
V_o	V_{load}	Load regulation voltage	$I_o = 1 \text{ to } 150 \text{ mA}$			25	mV
V_S, V_o	V_{dp}	Drop voltage	$I_o = 150 \text{ mA}$		180	400	mV
V_S, V_o	SVR	Ripple rejection	$f_r = 100 \text{ Hz}$	55			dB
V_S, V_o	I_{qs_1}	Current consumption with watchdog not active $I_{qs_1} = I_{VS} - I_o$	$V_S = 13.5 \text{ V}$; $I_o < 1 \text{ mA}$; $WE_n = \text{low}$		69	115	μA
V_S, V_o	I_{qs_10}	Current consumption with watchdog not active $I_{qs_10} = I_{VS} - I_o$	$V_S = 13.5 \text{ V}$; $I_o = 10 \text{ mA}$; $WE_n = \text{low}$		127	300	μA
V_S, V_o	I_{qs_50}	Current consumption with watchdog not active $I_{qs_50} = I_{VS} - I_o$	$V_S = 13.5 \text{ V}$; $I_o = 50 \text{ mA}$; $WE_n = \text{low}$		498	900	μA
V_S, V_o	I_{qs_150}	Current consumption with watchdog not active $I_{qs_150} = I_{VS} - I_o$	$V_S = 13.5 \text{ V}$; $I_o = 150 \text{ mA}$; $WE_n = \text{low}$		1.40	2	mA
V_S, V_o	I_{qn_1}	Current consumption with watchdog active $I_{qn_1} = I_{VS} - I_o$	$V_S = 13.5 \text{ V}$; $I_o < 1 \text{ mA}$; $WE_n = \text{high}$		110	170	μA
V_S, V_o	I_{qn_10}	Current consumption with watchdog active $I_{qn_10} = I_{VS} - I_o$	$V_S = 13.5 \text{ V}$; $I_o = 10 \text{ mA}$; $WE_n = \text{high}$		168	350	μA
V_S, V_o	I_{qn_50}	Current consumption with watchdog active $I_{qn_50} = I_{VS} - I_o$	$V_S = 13.5 \text{ V}$; $I_o = 50 \text{ mA}$; $WE_n = \text{high}$		538	1000	μA
V_S, V_o	I_{qn_150}	Current consumption with watchdog active $I_{qn_150} = I_{VS} - I_o$	$V_S = 13.5 \text{ V}$; $I_o = 150 \text{ mA}$; $WE_n = \text{high}$		1.45	2	mA
	T_w	Thermal protection temperature		150		190	$^\circ\text{C}$
	T_w_hy	Thermal protection temperature hysteresis			10		$^\circ\text{C}$

1. See [Figure 3](#).

Table 6. Reset

Pin	Symbol	Parameter	Test condition	Min.	Typ.	Max.	Unit
Res	Vres_l	Reset output low voltage	$R_{\text{ext}} = 5 \text{ k}\Omega$ to V_0 ; $V_0 > 1 \text{ V}$			0.4	V
Res	$I_{\text{Res_lkg}}$	Reset output high leakage current	$V_{\text{Res}} = 5 \text{ V}$			1	μA
Res	R_{Res}	Pull up internal resistance	Versus V_0	10	20	50	$\text{k}\Omega$
Res	$V_{\text{o_th}}$	Reset threshold voltage	$V_{\text{S}} = 5.6$ to 31 V ; $I_0 = 1$ to 150 mA	6%	8%	10%	Below $V_{\text{o_ref}}$
Vcr	V_{rth}	Reset timing low threshold	$V_{\text{S}} = 13.5 \text{ V}$	10%	13%	16%	$V_{\text{o_ref}}$
Vcr	V_{rthh}	Reset timing high threshold	$V_{\text{S}} = 13.5 \text{ V}$	44%	47%	50%	$V_{\text{o_ref}}$
Vcr	I_{cr}	Charge current	$V_{\text{S}} = 13.5 \text{ V}$	8	15	30	μA
Vcr	I_{dr}	Discharge current	$V_{\text{S}} = 13.5 \text{ V}$	8	15	30	μA
Res	$T_{\text{rr_2}}$	Reset reaction time ⁽¹⁾	$V_0 = V_{\text{o_th}} - 100 \text{ mV}$	100	250	700	μs
Res	T_{rd}	Reset delay time	$V_{\text{S}} = 13.5 \text{ V}$; $C_{\text{tr}} = 1 \text{ nF}$	65	115	165	ms

1. When V_0 becomes lower than 4 V, the reset reaction time decreases down to 2 μs assuring a faster reset condition in this particular case.

Table 7. Watchdog

Pin	Symbol	Parameter	Test condition	Min.	Typ.	Max.	Unit
Wi	Vih	Input high voltage	$V_{\text{S}} = 13.5 \text{ V}$	3.5			V
Wi	Vil	Input low voltage	$V_{\text{S}} = 13.5 \text{ V}$			1.5	V
Wi	Vih	Input hysteresis	$V_{\text{S}} = 13.5 \text{ V}$		500		mV
Wi	Rwi	Pull down resistor	$V_{\text{S}} = 13.5 \text{ V}$	30	100	250	$\text{k}\Omega$
Vcw	Vwhth	High threshold	$V_{\text{S}} = 13.5 \text{ V}$	44%	47%	50%	$V_{\text{o_ref}}$
Vcw	Vwlth	Low threshold	$V_{\text{S}} = 13.5 \text{ V}$	10%	13%	16%	$V_{\text{o_ref}}$
Vcw	Icwc	Charge current	$V_{\text{S}} = 13.5 \text{ V}$; $V_{\text{cw}} = 0.1 \text{ V}$	5	10	20	μA
Vcw	Icwd	Discharge current	$V_{\text{S}} = 13.5 \text{ V}$; $V_{\text{cw}} = 2.5 \text{ V}$	1.25	2.5	5	μA
Vcw	Twop	Watchdog period	$V_{\text{S}} = 13.5 \text{ V}$; $C_{\text{tw}} = 47 \text{ nF}$	20	40	80	ms
Res	twol	Watchdog output low time	$V_{\text{S}} = 13.5 \text{ V}$; $C_{\text{tw}} = 47 \text{ nF}$	4	8	16	ms

Table 8. Watchdog Enable

Pin	Symbol	Parameter	Test condition	Min.	Typ.	Max.	Unit
WE _n	V _{WE_n_l}	Enable input low voltage				1	V
WE _n	V _{WE_n_h}	Enable input high voltage		3			V
WE _n	V _{WE_n_hy}	Enable input hysteresis		600	920	1300	mV
WE _n	I _{_leak}	Pull down current	V _S = 13.5 V	1	2.5	5	μA

3 Application information

3.1 Voltage regulator

The voltage regulator uses a p-channel MOS transistor as a regulating element. With this structure a very low dropout voltage at current up to 150 mA is obtained. The output voltage is regulated up to transient input supply voltage of 40 V. No functional interruption due to over-voltage pulses is generated. The voltage Regulator is always active and not depending on the state of WE_n input pin. A short circuit protection to GND is provided.

Figure 3. Behavior of output current versus regulated voltage V_o

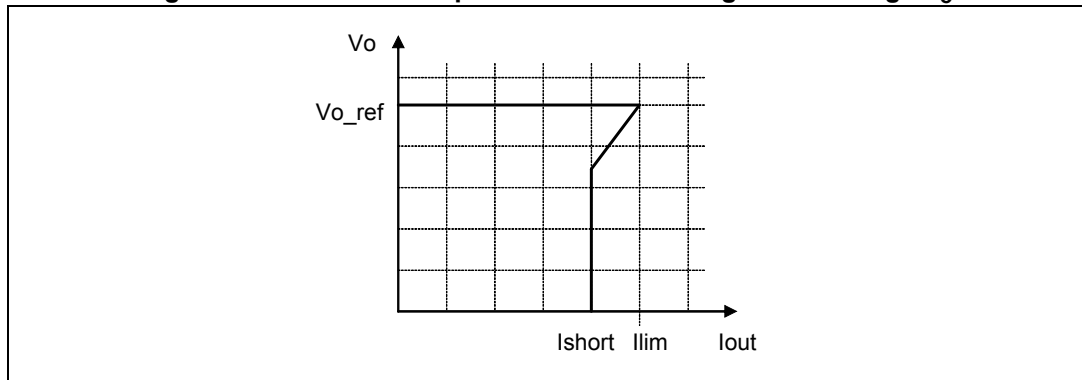

3.2 Reset

The reset circuit supervises the output voltage V_o. The V_{o_th} reset threshold is defined with the internal reference voltage and a resistor output divider. If the output voltage becomes lower than V_{o_th} then Res goes low with a reaction time t_{rr}. The reset low signal is guaranteed for an output voltage V_o greater than 1 V.

When the output voltage becomes higher than V_{o_th} then Res goes high with a delay t_{rd}. This delay is obtained by an internal oscillator.

The oscillator period is given by:

$$T_{osc} = [(V_{rth} - V_{rlth}) \times C_{tr}] / I_{cr} + [(V_{rth} - V_{rlth}) \times C_{tr}] / I_{dr}$$

where:

- I_{cr}: is an internally generated charge current
- I_{dr}: is an internally generated discharge current
- V_{rth}, V_{rlth}: are two voltages defined with the output voltage and a resistor output divider
- C_{tr}: is an external capacitance.

t_{rd} is given by:

$$t_{rd} = 512 \times T_{osc}$$

The Reset is always active and not depending on the state of WE_n input pin.

Figure 4. Reset timing diagram

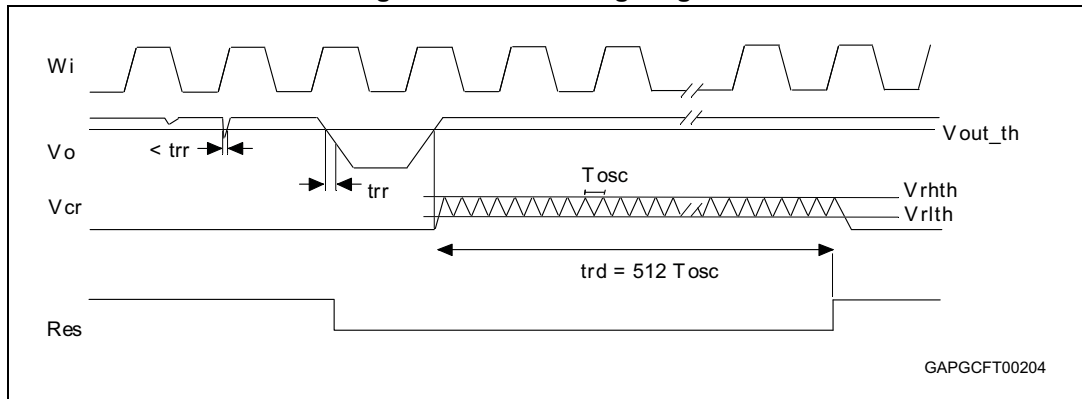

GAPGCF00204

3.3 Watchdog

A connected microcontroller is monitored by the watchdog input W_i . If pulses are missing, the Reset output pin is set to low. The pulse sequence time can be set within a wide range with the external capacitor, C_{tw} . The watchdog circuit discharges the capacitor C_{tw} with the constant current I_{cwd} . If the lower threshold V_{wlt} is reached, a watchdog reset is generated. To prevent this the microcontroller must generate a positive edge during the discharge of the capacitor before the voltage has reached the threshold V_{wlt} . In order to calculate the minimum time t , during which the micro-controller must output the positive edge, the following equation can be used:

$$(V_{whth} - V_{wlt}) \times C_{tw} = I_{cwd} \times t$$

Every W_i positive edge switches the current source from discharging to charging. The same happens when the lower threshold is reached. When the voltage reaches the upper threshold, V_{whth} , the current switches from charging to discharging. The result is a saw-tooth voltage at the watchdog timer capacitor C_{tw} .

Figure 5. Watchdog timing diagram

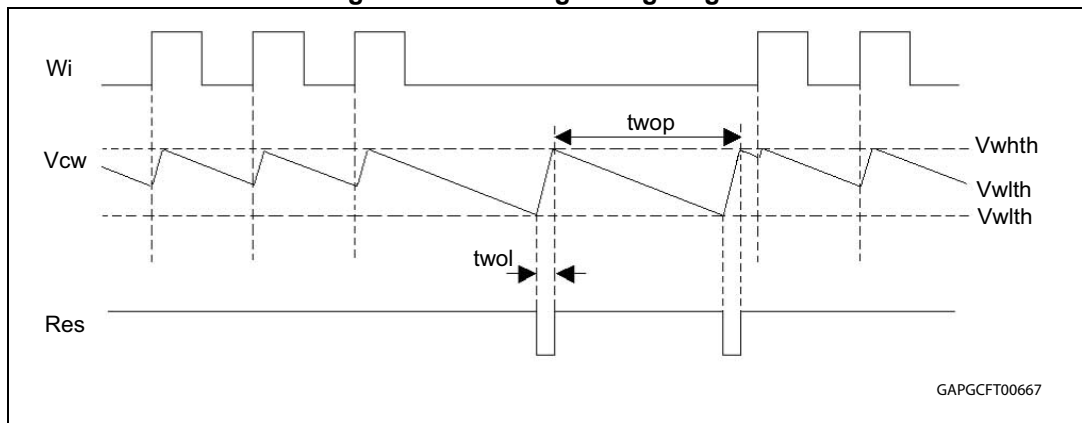

GAPGCF00667

Table 9. SO-8 mechanical data

Symbol	Millimeters		
	Min.	Typ.	Max.
A			1.75
A1	0.10		0.25
A2	1.25		
b	0.28		0.48
c	0.17		0.23
D ⁽¹⁾	4.80	4.90	5.00
E	5.80	6.00	6.20
E1 ⁽²⁾	3.80	3.90	4.00
e		1.27	
h	0.25		0.50
L	0.40		1.27
L1		1.04	
k	0°		8°
ccc			0.10

1. Dimensions D does not include mold flash, protrusions or gate burrs. Mold flash, protrusions or gate burrs shall not exceed 0.15 mm in total (both side).
2. Dimension "E1" does not include interlead flash or protrusions. Interlead flash or protrusions shall not exceed 0.25 mm per side.

4.3 SO-20 package information

Figure 7. SO-20 package dimensions

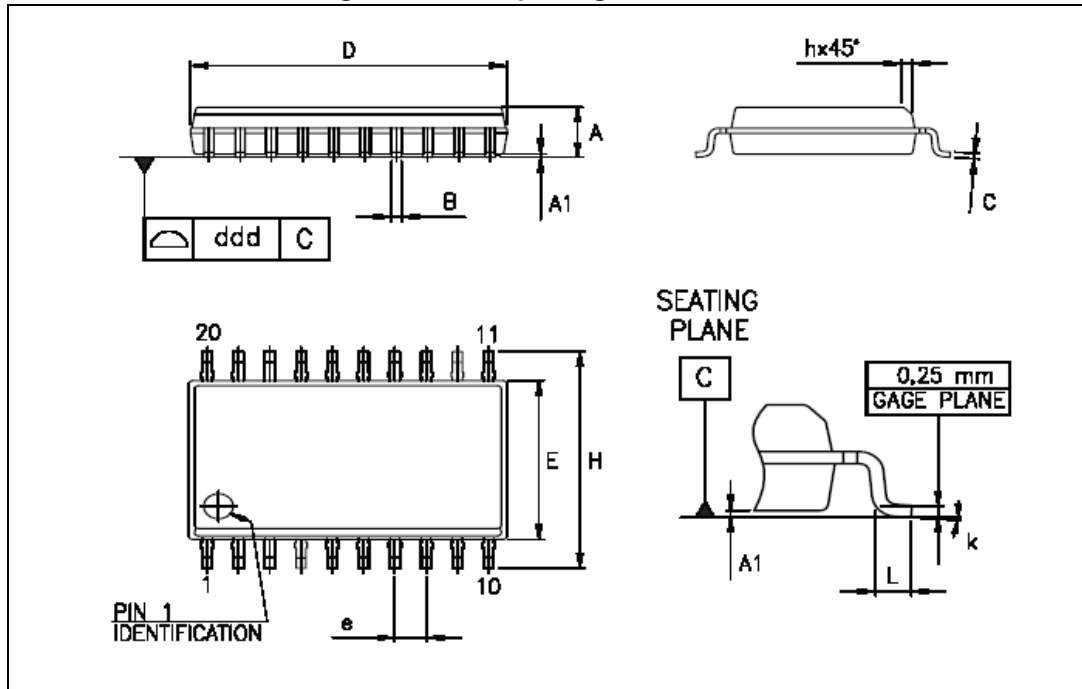

Table 10. SO-20 mechanical data

Symbol	Millimeters		
	Min.	Typ.	Max.
A	2.35		2.65
A1	0.10		0.30
B	0.33		0.51
C	0.23		0.32
D ⁽¹⁾	12.60		13.00
E	7.40		7.60
e		1.27	
H	10.0		10.65
h	0.25		0.75
L	0.40		1.27
k	0°		8°
ddd			0.10

1. "D" dimension does not include mold flash, protusions or gate burrs. Mold flash, protusions or gate burrs shall not exceed 0.15 mm per side.

4.4 SO-8 packing information

Figure 8. SO-8 tube shipment (no suffix)

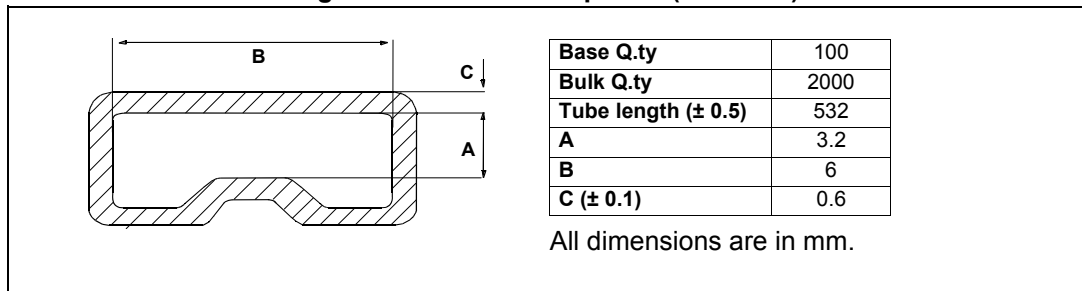
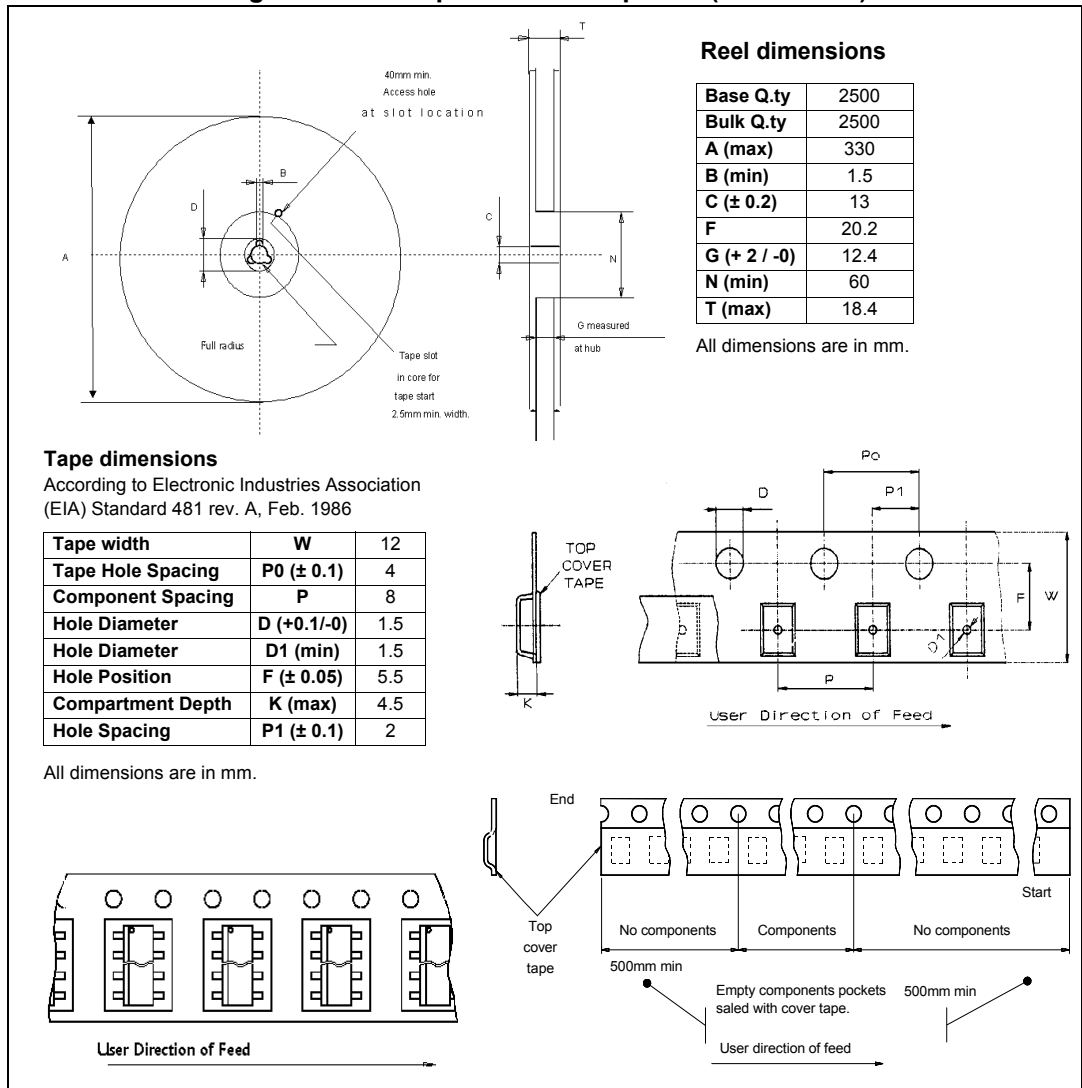

Figure 9. SO-8 tape and reel shipment (suffix "TR")



4.5 SO-20 packing information

Figure 10. SO-20 tube shipment (no suffix)

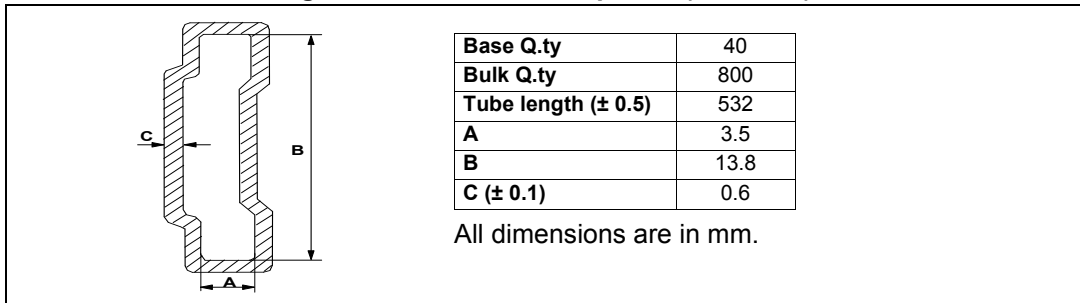
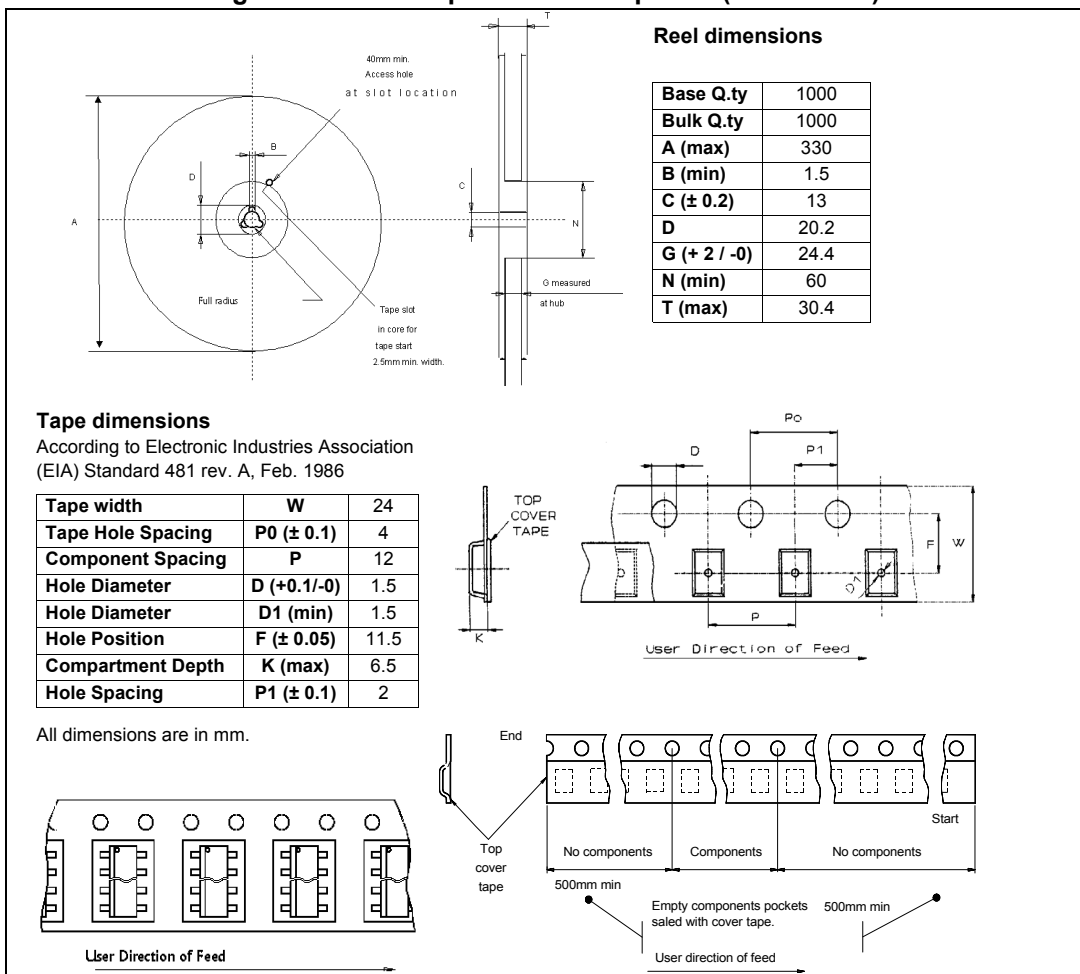

Figure 11. SO-20 tape and reel shipment (suffix "TR")



5 Revision history

Table 11. Document revision history

Date	Revision	Changes
16-Apr-2012	1	Initial release. This document replace the L4989 datasheet.
19-Sep-2013	2	Updated Disclaimer.
01-Oct-2018	3	Updated title and added the feature "AEC-Q100 qualified" in cover page with automotive logo.

IMPORTANT NOTICE – PLEASE READ CAREFULLY

STMicroelectronics NV and its subsidiaries (“ST”) reserve the right to make changes, corrections, enhancements, modifications, and improvements to ST products and/or to this document at any time without notice. Purchasers should obtain the latest relevant information on ST products before placing orders. ST products are sold pursuant to ST’s terms and conditions of sale in place at the time of order acknowledgement.

Purchasers are solely responsible for the choice, selection, and use of ST products and ST assumes no liability for application assistance or the design of Purchasers’ products.

No license, express or implied, to any intellectual property right is granted by ST herein.

Resale of ST products with provisions different from the information set forth herein shall void any warranty granted by ST for such product.



ST and the ST logo are trademarks of ST. All other product or service names are the property of their respective owners.

Information in this document supersedes and replaces information previously supplied in any prior versions of this document.

© 2018 STMicroelectronics – All rights reserved

Looking for pricing, stock, or lifecycle information?

Click below to explore more details on WIN SOURCE:

-  [View L4989MD013TR](#) on WIN SOURCE
-  [STMicroelectronics](#) Information

Optimize Your Supply Chain with WIN SOURCE Solutions

-  Global Sourcing Solution
-  Obsolete Management
-  Cost Control Management
-  Shortage Management
-  Alternative Solution
-  Excess Inventory Management