



**THE DATASHEET OF
L6377D013TR**



0.5 A high-side driver quad intelligent power switch

Datasheet - production data

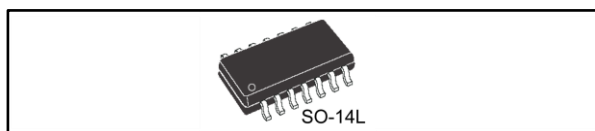

- Protection against surge transient (IEC 61000-4-5)
- Immunity against burst transient (IEC 61000-4-4)

Features

- Multipower BCD technology
- 0.5 A output current
- 8 to 35 V supply voltage range
- External programmable current limit
- Non-dissipative overcurrent protection
- Thermal shutdown
- Undervoltage lockout with hysteresis
- Diagnostic output for undervoltage, overtemperature and overcurrent
- External asynchronous reset input
- Presettable delay for overcurrent diagnostic
- Open ground protection

Description

This device is a monolithic intelligent power switch in multipower BCD technology to drive inductive, capacitive or resistive loads. Diagnostic for CPU feedback and extensive use of electrical protections make this device robust and suitable for general purpose industrial applications.

Table 1: Device summary

Order code	Package	Packing
L6377D	SO-14L	Tube
L6377D013TR		Tape and reel

Contents

1 Pin connections..... 5

2 Maximum ratings 6

3 Electrical characteristics 7

 3.1 Schematic diagram 9

 3.2 Input section..... 10

 3.3 Overtemperature protection 10

 3.4 Undervoltage protection 10

4 Overcurrent operation..... 11

5 Demagnetization of inductive loads..... 13

6 Package information 15

 6.1 SO-14L package information..... 15

7 Revision history 18



List of tables

Table 1: Device summary	1
Table 2: Pin description	5
Table 3: Absolute maximum ratings	6
Table 4: Thermal data.....	6
Table 5: Electrical characteristics	7
Table 6: SO-14L package mechanical data	16
Table 7: Document revision history	18

List of figures

Figure 1: Pin connections (top view).....	5
Figure 2: Block diagram.....	9
Figure 3: Undervoltage comparator hysteresis.....	9
Figure 4: Switching waveforms.....	10
Figure 5: Short-circuit operation waveforms.....	11
Figure 6: Input comparator hysteresis.....	13
Figure 7: External demagnetisation circuit (versus ground).....	13
Figure 8: External demagnetisation circuit.....	14
Figure 9: SO-14L package outline.....	15
Figure 10: SO-14L recommended footprint outline.....	17

1 Pin connections

Figure 1: Pin connections (top view)

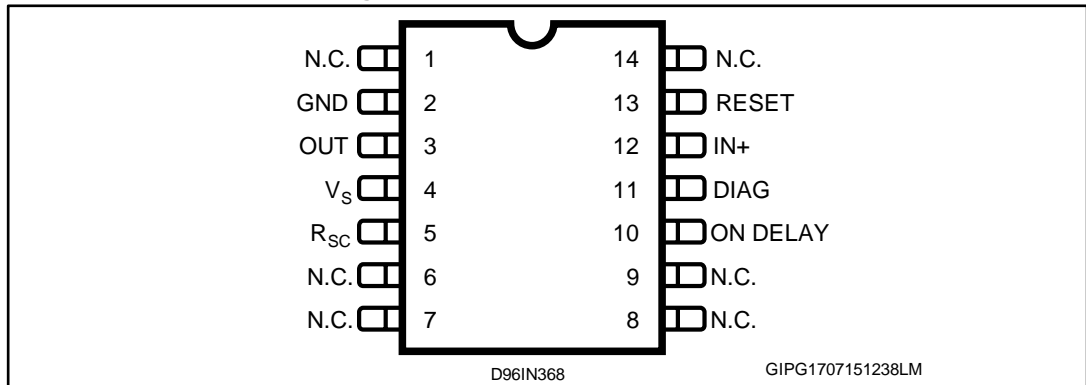

Table 2: Pin description

Pin	Pin name	Function
1, 6, 7, 8, 9, 14	N.C.	Not connected
2	GND	Ground pin
3	OUT	High-side output. Controlled output with current limitation
4	V _S	Supply voltage. Range with undervoltage monitoring
5	R _{SC}	Current limiting setting
10	ON DELAY	Delay setting for overcurrent diagnostic
11	DIAG	Diagnostic open drain output for overtemperature, undervoltage and overcurrent
12	IN+	Comparator non-inverting input
13	RESET	Asynchronous reset input

2 Maximum ratings

Table 3: Absolute maximum ratings

Symbol	Parameter	Value	Unit
V_s	Pin 4: supply voltage ($t_w \leq 10$ ms)	50	V
	Pin 4: supply voltage (DC)	40	V
$V_s - V_{OUT}$	Pin 4 vs 3: supply to output differential voltage	Internally limited	V
V_{od}	Pin 10: externally forced voltage	-0.3 to 7	V
I_{od}	Pin 10: externally forced current	± 1	mA
I_{RESET}	Pin 13: reset input current (forced)	± 2	mA
V_{RESET}	Pin 13: reset input voltage	-0.3 to 40	V
I_{out}	Pin 3: output current	Internally limited	
V_{out}	Pin 3: output voltage	Internally limited	W
E_{il}	Total energy inductive load: ($T_J = 125$ °C)	50	mJ
P_{tot}	Power dissipation	Internally limited	
V_{diag}	Pin 11: external voltage	-0.3 to 40	V
I_{diag}	Pin 11: externally forced current	-10 to 10	mA
I_i	Pin 12: input current	20	mA
V_i	Pin 12: input voltage	-10 to $V_s + 0.3$	V
T_{op}	Ambient temperature, operating range	-25 to 85	°C
T_J	Junction temperature, operating range	-25 to 125	°C
T_{stg}	Storage temperature	-55 to 150	°C

Table 4: Thermal data

Symbol	Parameter	Value	Unit
$R_{th(JA)}$	Thermal resistance junction-ambient	150 max.	°C/W

3 Electrical characteristics

$V_S = 24\text{ V}$; $T_J = -25\text{ to }125\text{ }^\circ\text{C}$, unless otherwise specified

Table 5: Electrical characteristics

Symbol	Pin	Parameter	Test conditions	Min.	Typ.	Max.	Unit	
DC operation								
V_{Smin}	4	Supply voltage for valid diagnostic	$I_{diag} \geq 0.5\text{ mA}$; $V_{diag} = 1.5\text{ V}$;	4		35	V	
V_S		Operative supply voltage		8	24	35	V	
V_{sth}		Undervoltage lower threshold		7		8	V	
V_{shys}		Undervoltage hysteresis		300	500	700	mV	
I_q		Quiescent current	Output pen			800		μA
I_{qo}			Output on			1.6		mA
V_{ith}	12	Input threshold voltage		0.8	1.3	2	V	
V_{iths}		Input threshold hysteresis		50		400	mV	
V_{il}		Input low level voltage		-7		0.8	V	
V_{ih}		Input high level voltage	$V_S < 18\text{ V}$	2		$V_S - 3$	V	
			$V_S > 18\text{ V}$	2		15		
I_{ib}	Input bias current	$V_i = -7\text{ to }15\text{ V}$	-250		250	μA		
V_{rth}	13	Reset threshold voltage		0.8	1.3	2	V	
V_{rl}		Reset low level voltage		0		0.8	V	
V_{rh}		Reset high level voltage		2		40	V	
I_{rb}		Reset pull down current				5	μA	
I_{dch}	10	Delay capacitor charging current	ON delay pin shorted-to-ground		2.5		μA	
V_{rsc}	5	Output voltage on R_{SC} pin	R_{SC} pin floating		1.25		V	
I_{rsc}		Output current on R_{SC} pin	R_{SC} pin shorted-to-GND			300	μA	
I_{dlkg}	11	Diagnostic output leakage current	Diagnostic off			25	μA	
V_{diag}		Diagnostic output voltage drop	$I_{diag} = 5\text{ mA}$			1.5	V	
V_{don}	3	Output voltage drop	$I_{out} = 625\text{ mA}$ $T_J = 25\text{ }^\circ\text{C}$		250	350	mV	
			$I_{out} = 625\text{ mA}$ $T_J = 125\text{ }^\circ\text{C}$		400	500		
I_{olk}		Output leakage current	$V_i = \text{low}; V_{out} = 0$			100	μA	
V_{ol}		Output low-state voltage	$V_i = \text{high}; \text{pin floating}$		0.8	1.5	V	
V_{cl}		Internal voltage clamp ($V_S - V_{out}$)	$I_o = 200\text{ mA}$ single pulsed = 300 ms	48	53	58	V	

Symbol	Pin	Parameter	Test conditions	Min.	Typ.	Max.	Unit
I_{SC}		Short-circuit output current	$V_S = 8$ to 35 V; $R_I = 2$ Ω ; $R_{SC} = 5$ to 30 k Ω	$5/R_{SC} =$ k Ω			A
$T_{max.}$		Overtemperature upper threshold			150		$^{\circ}$ C
T_{hys}		Overtemperature hysteresis			20		$^{\circ}$ C
AC operation							
t_r - t_f	3	Rise or fall time	$V_S = 24$ V; $R_I = 70$ Ω R_I to ground		20		μ s
t_d		Delay time			5		
dV/dt		Slew rate (rise and fall edge)	$V_S = 24$ V; $R_I = 70$ Ω R_I to ground	0.7	1	1.5	V/ μ s
t_{ON}	10	On-time during short-circuit condition	50 pF < C_{DON} < 2 nF		1.28		μ s/pF
t_{OFF}		Off-time during short-circuit condition			64		t_{ON}
$f_{max.}$		Maximum operating frequency			25		kHz
Source drain NDMOS diode							
V_{fSD}		Forward on voltage	$I_{fSD} = 625$ mA		1	1.5	V
I_{fp}		Forward peak current	$t_p = 10$ ms; duty cycle = 20%			1.5	A
t_{rr}		Reverse recovery time	$I_{fSD} = 500$ mA; $dI_{fSD}/dt = 25$ A/ μ s		200		ns
t_{fr}		Forward recovery time			50		ns

3.1 Schematic diagram

Figure 2: Block diagram

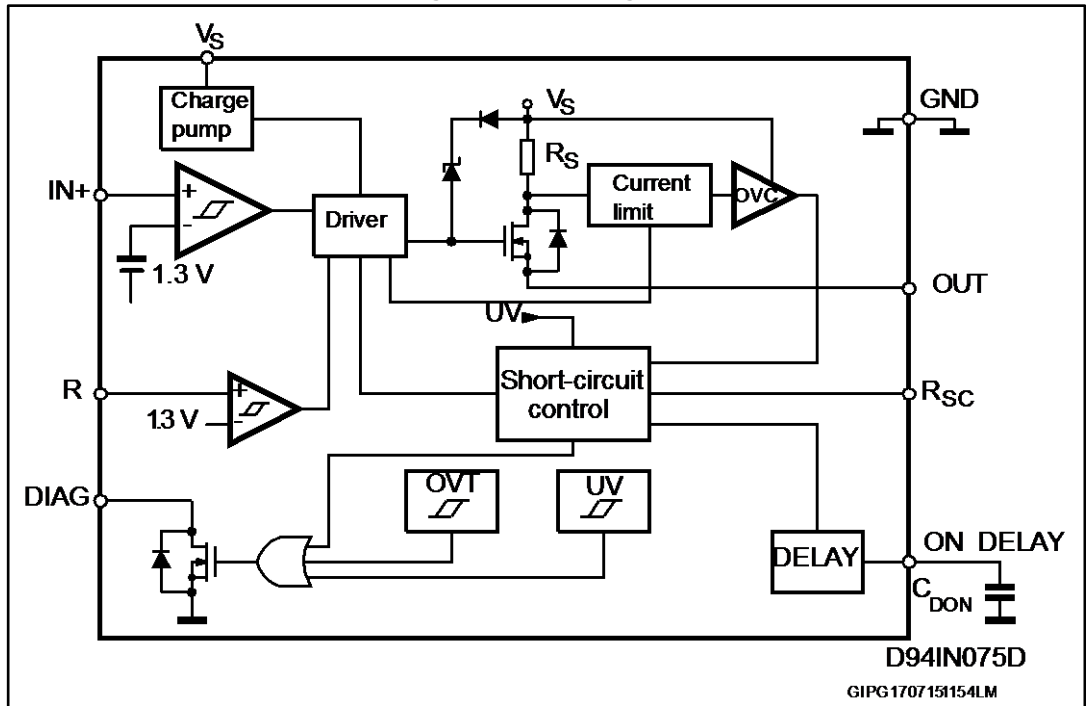

Figure 3: Undervoltage comparator hysteresis

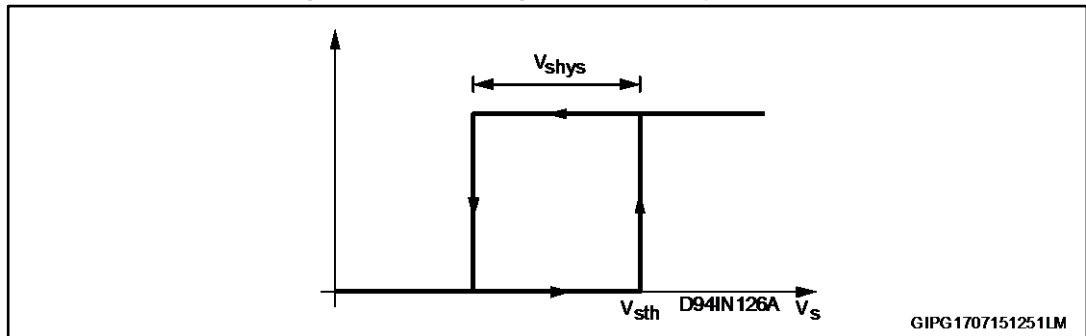
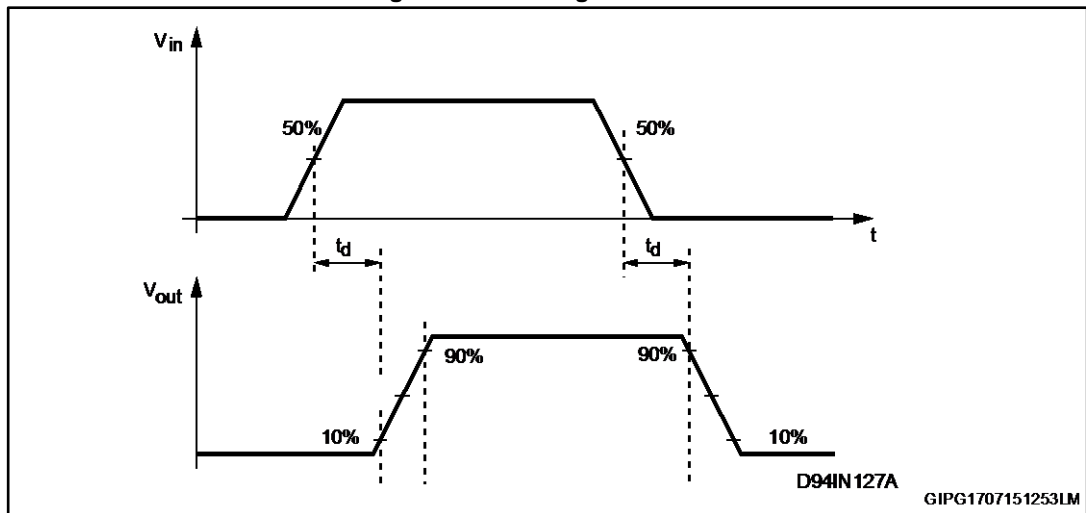

Figure 4: Switching waveforms



3.2 Input section

An input and asynchronous reset, TTL/CMOS compatible with wide voltage range and high noise immunity (thanks to a built-in hysteresis) is available.

3.3 Overtemperature protection

An on-chip overtemperature protection provides an excellent protection of the device in extreme conditions. Whenever the temperature, measured on a central portion of the chip, exceeds $T_{max} = 150\text{ °C}$ (typical value) the device shuts down, and the DIAG output goes low. Normal operation is resumed as the chip temperature (normally after few seconds) falls below $T_{max} - T_{hys} = 130\text{ °C}$ (typical value). The hysteresis avoids that an intermittent behavior occurs.

3.4 Undervoltage protection

The supply voltage operates correctly in a range from 8 to 35 V. Below 8 V the overall system has to be considered not reliable. To avoid any malfunctioning, the supply voltage is continuously monitored to provide an undervoltage protection. As V_s falls below $V_{sth} - V_{shys}$ (typically 7.5 V, see [Figure 4: "Switching waveforms"](#)) the output power MOSFET switches off and DIAG output goes low. Normal operation is resumed as soon as V_s exceeds V_{sth} . The hysteretic behaviour prevents intermittent operation at low supply voltage.

4 Overcurrent operation

In order to implement a short-circuit protection, the output power MOSFET is driven to linear mode to limit the output current to the I_{SC} value. This I_{SC} limit is externally set by an external 1/4 W resistor connected from R_{SC} pin and GND. The value of the resistor must be chosen according to the following formula:

Equation 1:

$$I_{sc} \text{ (A)} = 5/R_{SC} \text{ (kohm)} \text{ with } 5 < R_{SC} < 30 \text{ (kohm)}.$$

Concerning $R_{SC} < 5$ (kohm) I_{SC} is limited to $I_{SC} = 1.1$ A (typical value).

This condition (current limited to the I_{SC} value) lasts for a t_{ON} time interval, that can be set by a capacitor (C_{DON}) connected to the ON DELAY pin according to the following formula:

Equation 2:

$$t_{ON} = 1.28 \mu\text{sec/pF} \text{ for } 50 \text{ pF} < C_{DON} < 2 \text{ nF}$$

After the t_{ON} interval has expired the output power MOSFET switches off for the t_{OFF} time interval:

Equation 3:

$$t_{OFF} = 64 \cdot t_{ON}.$$

Figure 5: Short-circuit operation waveforms

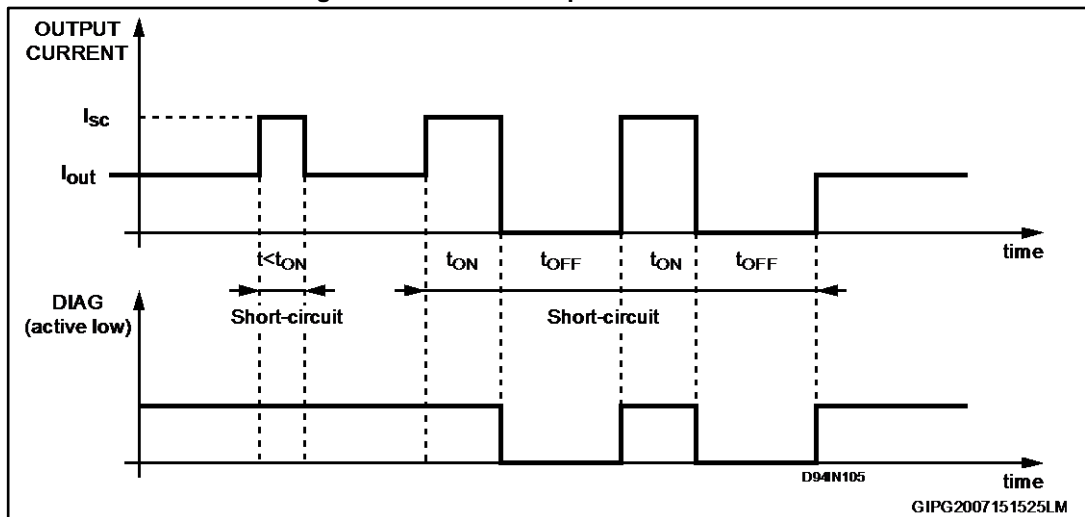

When the t_{OFF} interval has expired, the output power MOSFET switches on. In this manner two conditions may occur:

- the overload is still present. In this case, the output power MOSFET is again driven to linear mode (limiting the output current to I_{SC}) for another t_{ON} , starting a new cycle
- the overload condition is removed, and the output power MOSFET is no longer driven to linear mode

Please, see the DIAG pin (see [Figure 5: "Short-circuit operation waveforms"](#)). This unique feature is called short-circuit protection and it ensures a very safe operation even in permanent overload conditions. Note that, the choice of the most appropriate value for the t_{ON} interval (the value of the C_{DON} capacitor), a delay (the t_{ON} itself) prevents a misleading short-circuit information is presented on the DIAG output, when capacitive loads are driven

or incandescent lamp (a cold filament has a very low resistive value). The non-dissipative short-circuit protection can be disabled (keeping $t_{ON} = 0$ but with the output current still limited to I_{SC} , and diagnostic disabled) simply shorting to ground the ON DELAY pin.

5 Demagnetization of inductive loads

The L6377 has an internal clamping Zener diode, which demagnetises inductive loads. Note that the limitation comes from the peak power that the package can handle. Attention must be paid to a proper thermal design of the board. If load current or inductive value are too big, the peak power dissipation is too high, an external Zener plus diode can perform a demagnetisation versus ground or versus V_s (see [Figure 5: "Short-circuit operation waveforms"](#) and [Figure 6: "Input comparator hysteresis"](#)). The breakdown voltage of the external Zener diode must be chosen considering the internal clamping voltage (V_{cl}) and the supply voltage (V_s) according to:

Equation 4:

$$V_z < V_{cl(min.)} - V_{s(max.)}$$

for demagnetisation versus ground or

Equation 5:

$$V_{s(max.)} < V_z < V_{cl(min.)}$$

for demagnetisation versus V_s .

Figure 6: Input comparator hysteresis

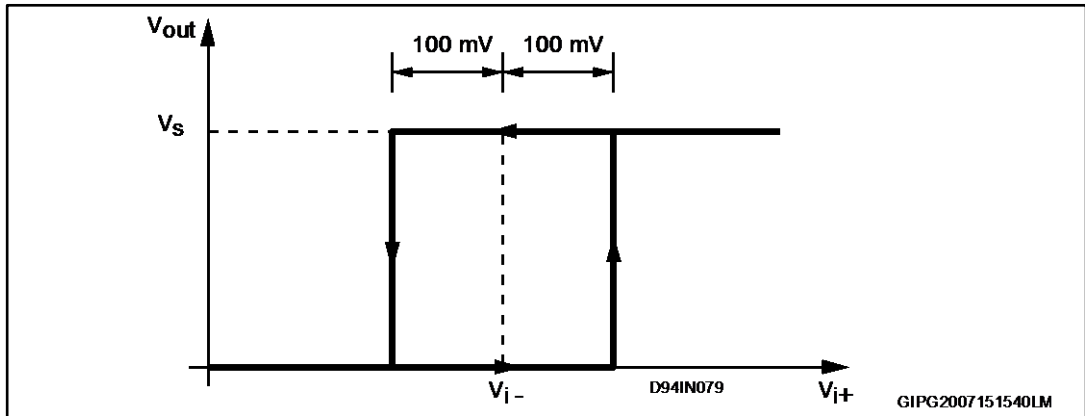

Figure 7: External demagnetisation circuit (versus ground)

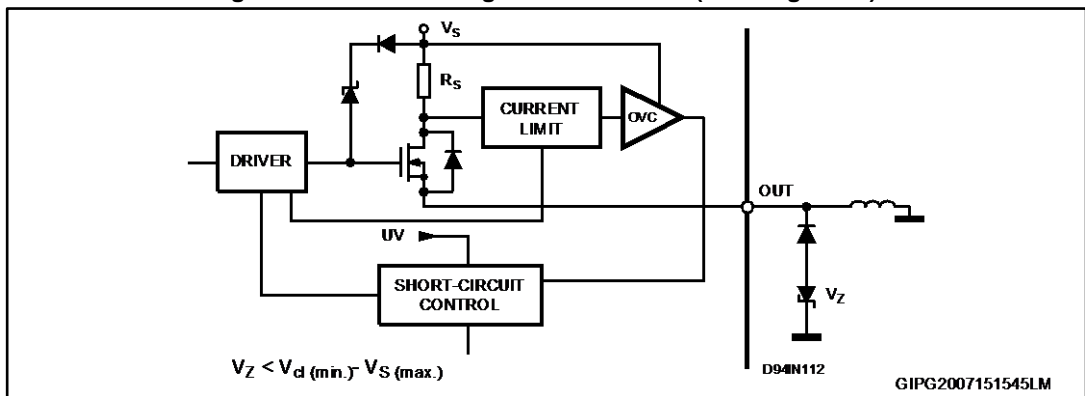
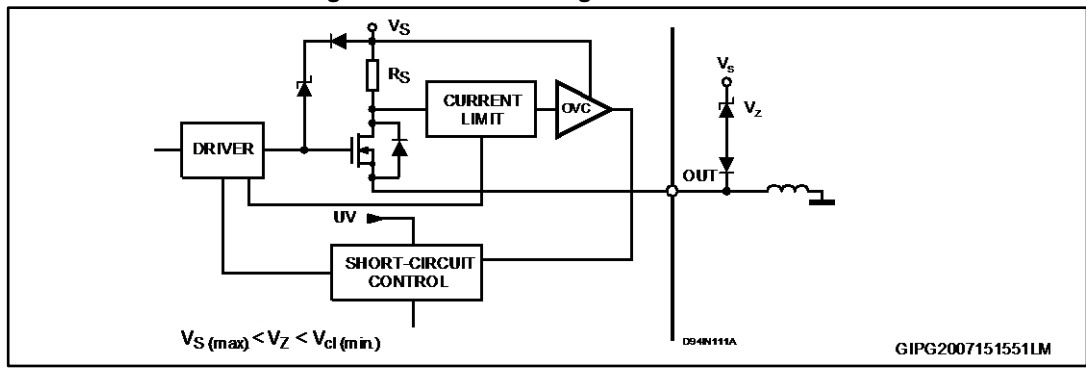

Figure 8: External demagnetisation circuit



6 Package information

In order to meet environmental requirements, ST offers these devices in different grades of ECOPACK[®] packages, depending on their level of environmental compliance. ECOPACK[®] specifications, grade definitions and product status are available at: www.st.com. ECOPACK[®] is an ST trademark.

6.1 SO-14L package information

Figure 9: SO-14L package outline

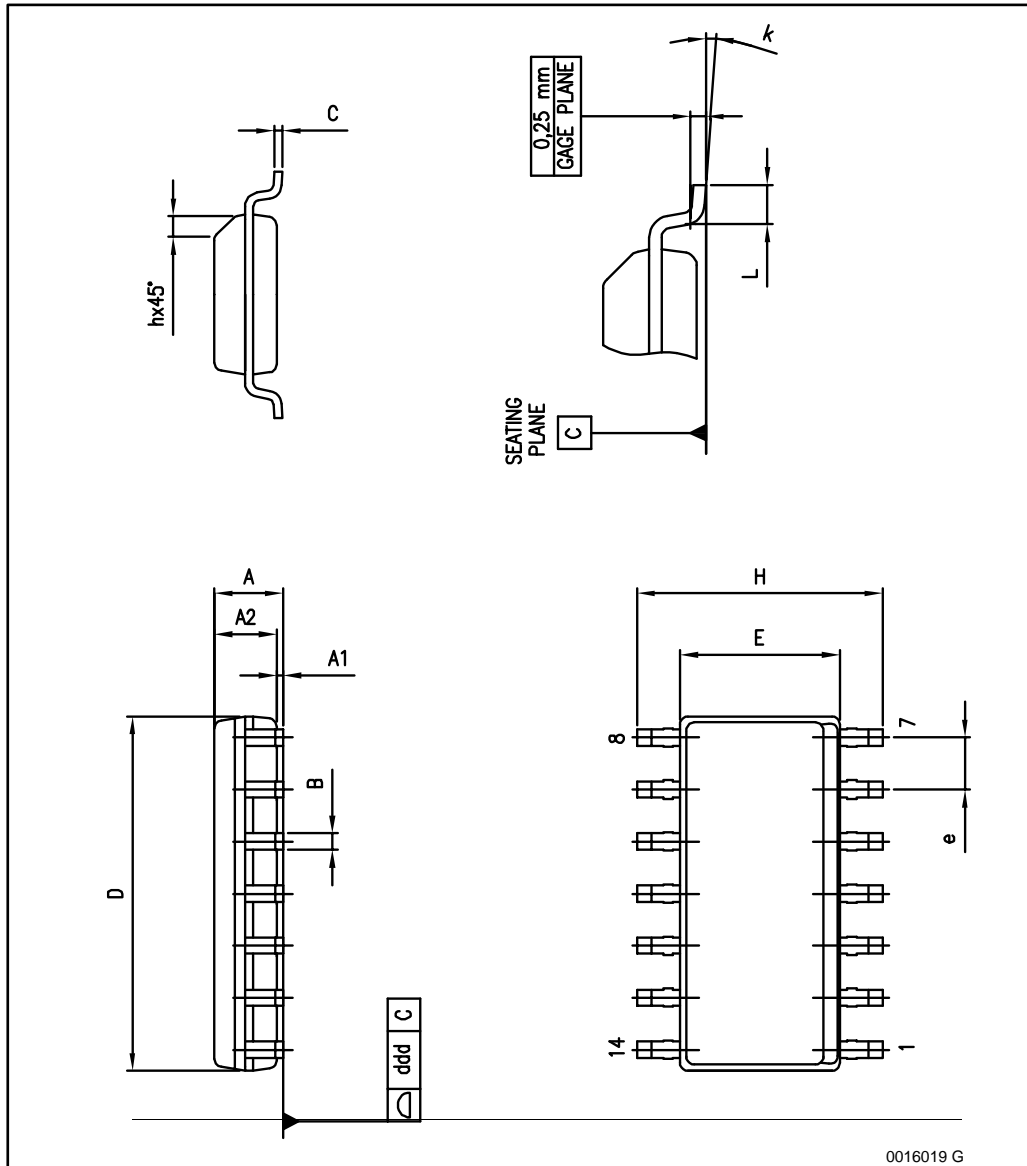

Table 6: SO-14L package mechanical data

Dim.	mm		
	Min.	Typ.	Max.
A	1.35		1.75
A1	0.10		0.25
A2	1.10	3.30	1.65
B	0.19		0.25
C	1.14	1.52	1.78
D	8.55		8.75
E	3.80		4.00
e		1.27	
H	5.80		6.20
h	0.25		0.50
L	0.40		1.27
k	0		8
ddd			0.10



Dimension D doesn't include mold flash, protrusions or gate burrs, which do not exceed 0.15 mm per side.



Drawing dimensions include single and matrix versions.

Figure 10: SO-14L recommended footprint outline

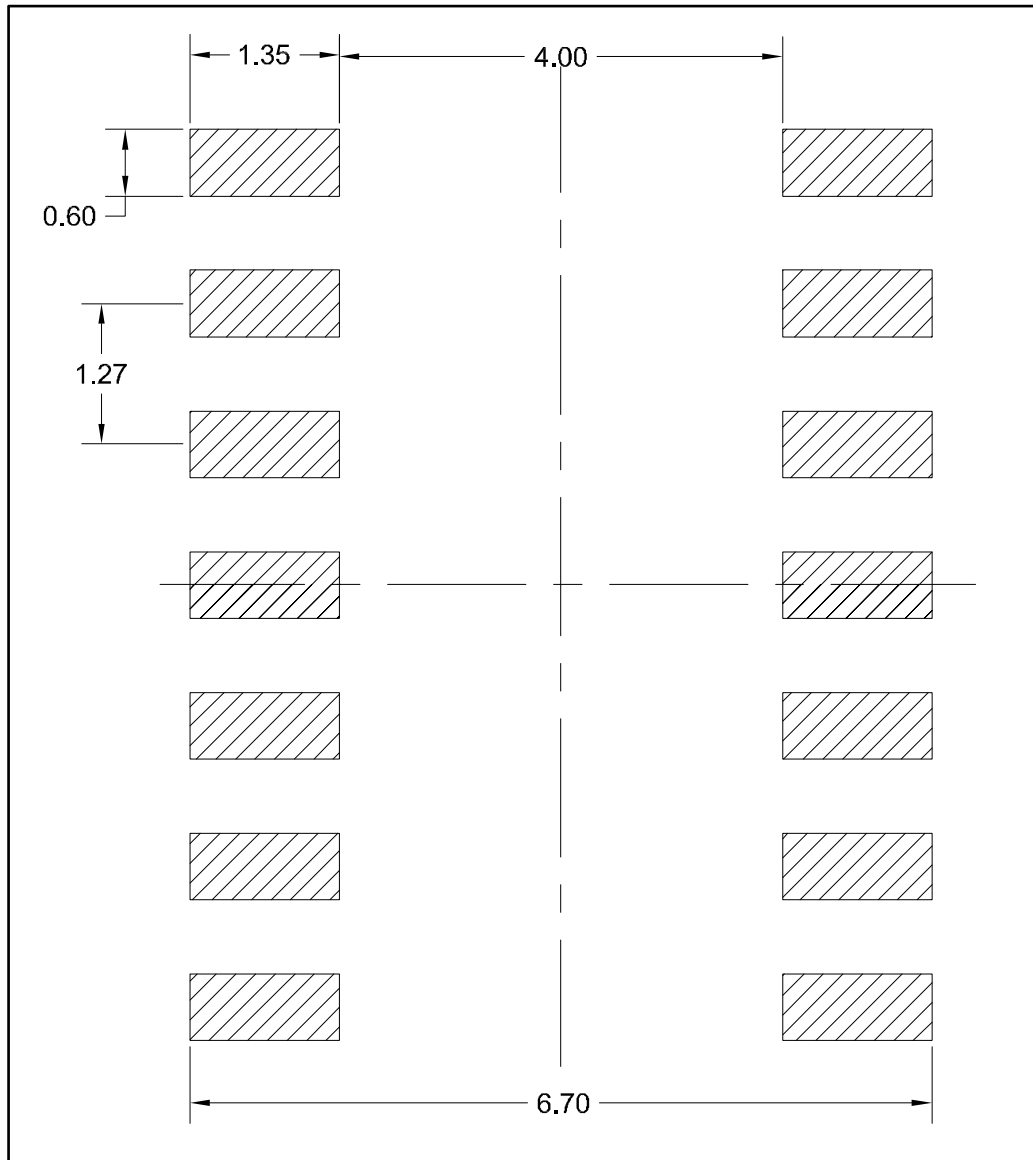

7 Revision history

Table 7: Document revision history

Date	Revision	Changes
17-Aug-2001	1	Initial release.
19-Apr-2005	2	Changed style sheet
22-Jun-2007	3	Changed style sheet
25-Feb-2008	4	Removed obsolete package DIP-14
24-Jul-2015	5	Updated I_{RESET} and V_{RESET} parameter in the table of maximum ratings.

IMPORTANT NOTICE – PLEASE READ CAREFULLY

STMicroelectronics NV and its subsidiaries ("ST") reserve the right to make changes, corrections, enhancements, modifications, and improvements to ST products and/or to this document at any time without notice. Purchasers should obtain the latest relevant information on ST products before placing orders. ST products are sold pursuant to ST's terms and conditions of sale in place at the time of order acknowledgement.

Purchasers are solely responsible for the choice, selection, and use of ST products and ST assumes no liability for application assistance or the design of Purchasers' products.

No license, express or implied, to any intellectual property right is granted by ST herein.

Resale of ST products with provisions different from the information set forth herein shall void any warranty granted by ST for such product.

ST and the ST logo are trademarks of ST. All other product or service names are the property of their respective owners.

Information in this document supersedes and replaces information previously supplied in any prior versions of this document.

© 2015 STMicroelectronics – All rights reserved

Looking for pricing, stock, or lifecycle information?

Click below to explore more details on WIN SOURCE:

-  [View L6377D013TR on WIN SOURCE](#)
-  [STMicroelectronics Information](#)

Optimize Your Supply Chain with WIN SOURCE Solutions

-  Global Sourcing Solution
-  Obsolete Management
-  Cost Control Management
-  Shortage Management
-  Alternative Solution
-  Excess Inventory Management