



THE DATASHEET OF L6714TR





L6714

4 phase controller with embedded drivers for Intel VR10, VR11 and AMD 6Bit CPUs

Features

- 0.5% output voltage accuracy
- 7/8 bit programmable output up to 1.60000V - Intel VR10.x, VR11 DAC
- 6 bit programmable output up to 1.5500V - AMD 6Bit DAC
- High current integrated gate drivers
- Full differential current sensing across inductor or low side MOSFET
- Embedded VRD thermal monitor
- Integrated remote sense buffer
- Dynamic VID management
- Adjustable reference voltage offset
- Programmable Soft-Start
- Low-Side-Less startup
- Programmable over voltage protection
- Preliminary over voltage
- Constant over current protection
- Oscillator internally fixed at 150kHz externally adjustable
- Output enable
- SS_END / PGOOD signal
- TQFP64 10mm x 10mm package with Exposed Pad

Application:

- High current VRD for desktop CPUs
- ▼ Workstation and server CPU power supply
- VRM modules

Order codes

Part number	Package	Packaging
L6714	TQFP64	Tube
L6714TR	TQFP64	Tape and reel

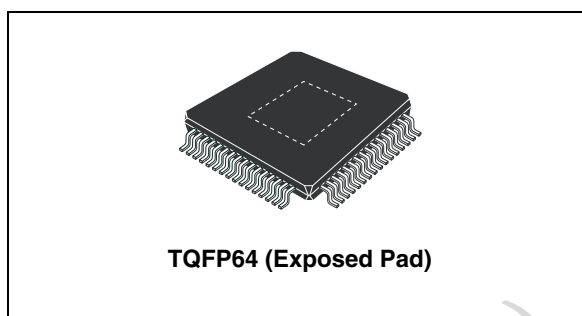

Description

L6714 implements a four phase step-down controller with 90° phase shift between each phase with integrated high current drivers in a compact 10mm x 10mm body package with exposed pad.

The device embeds selectable DACs: the output voltage ranges up to 1.60000V (both Intel VR10.x and VR11 DAC) or up to 1.5500V (AMD 6Bit DAC) managing D-VID with $\pm 0.5\%$ output voltage accuracy over line and temperature variations. Additional programmable offset can be added to the reference voltage with a single external resistor.

The controller assures fast protection against load over current and under / over voltage (in this last case also before UVLO). In case of over-current the system works in Constant Current mode until UVP.

Selectable current reading adds flexibility to the design allowing current sense across inductor or LS MOSFET.

System Thermal Monitor is also provided allowing system protection from over-temperature conditions.

Contents

1	Block diagram	5
2	Pin settings	6
	2.1 Connections	6
	2.2 Functions	7
3	Electrical data	13
	3.1 Maximum rating	13
	3.2 Thermal data	13
4	Electrical characteristics	14
5	VID Tables	17
	5.1 Mapping for the Intel VR11 mode	17
	5.2 Voltage Identification (VID) for Intel VR11 mode	17
	5.3 Voltage Identifications (VID) for Intel VR10 mode + 6.25mV	19
	5.4 Mapping for the AMD 6BIT mode	21
	5.5 Voltage identifications (VID) codes for AMD 6BIT mode	21
6	Reference schematic	23
7	Device description	27
8	Configuring the device	28
	8.1 DAC selection	28
9	Power dissipation	30
10	Current reading and current sharing loop	32
	10.1 Low side current reading	33
	10.2 Inductor current reading	33
11	Remote voltage sense	35

12	Voltage positioning	36
	12.1 Droop function (Optional)	37
	12.2 Offset (Optional)	38
13	Dynamic VID transitions	39
14	Enable and disable	41
15	Soft start	42
	15.1 Intel mode	43
	15.2 AMD mode	44
	15.3 Low-Side-Less startup	46
16	Output voltage monitor and protections	47
	16.1 Under voltage	47
	16.2 Preliminary over voltage	47
	16.3 Over voltage and programmable OVP	48
	16.4 PGOOD (Only for AMD mode)	48
17	Maximum Duty-cycle limitation	49
18	Over current protection	50
	18.1 Low side MOSFET sense over current	51
	18.2 Inductor sense over current	53
19	Oscillator	54
20	Driver section	56
21	System control loop compensation	57
	21.1 Compensation network guidelines	59
22	Thermal monitor	60

23	Tolerance band (TOB) definition	61
23.1	Controller tolerance (TOB controller)	61
23.2	Ext. current sense circuit tolerance (TOB CurrSense - Inductor Sense)	62
23.3	Time constant matching error tolerance (TOB TCMatching)	63
23.4	Temperature measurement error (VTC)	63
24	Layout guidelines	64
24.1	Power components and connections	64
24.2	Small signal components and connections	65
25	Embedding L6714 - Based VR...	66
26	Package mechanical data	67
27	Revision history	69

Obsolete Product(s) - Obsolete Product(s)

1 Block diagram

Figure 1. L6714 block diagram

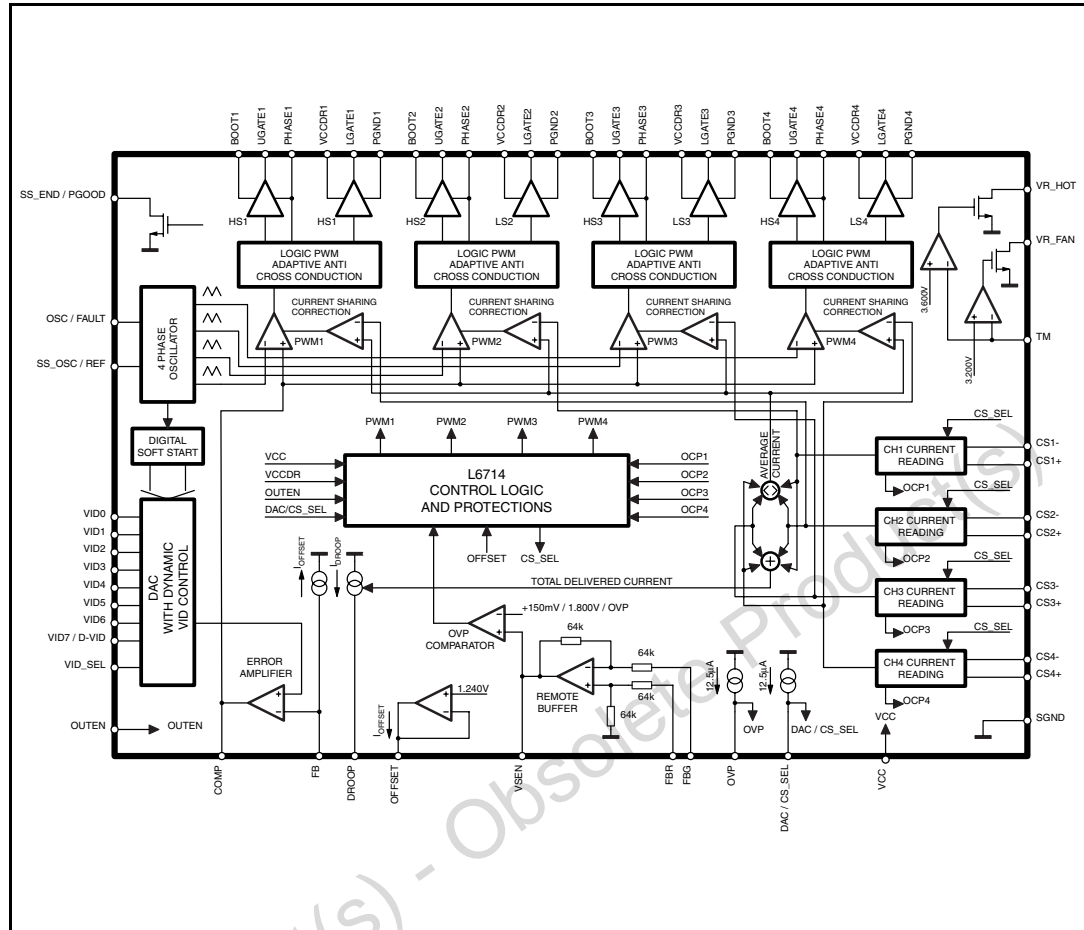

Obsolete Product(s) - Obsolete Product(s)

2 Pin settings

2.1 Connections

Figure 2. Pin connection (Through top view)

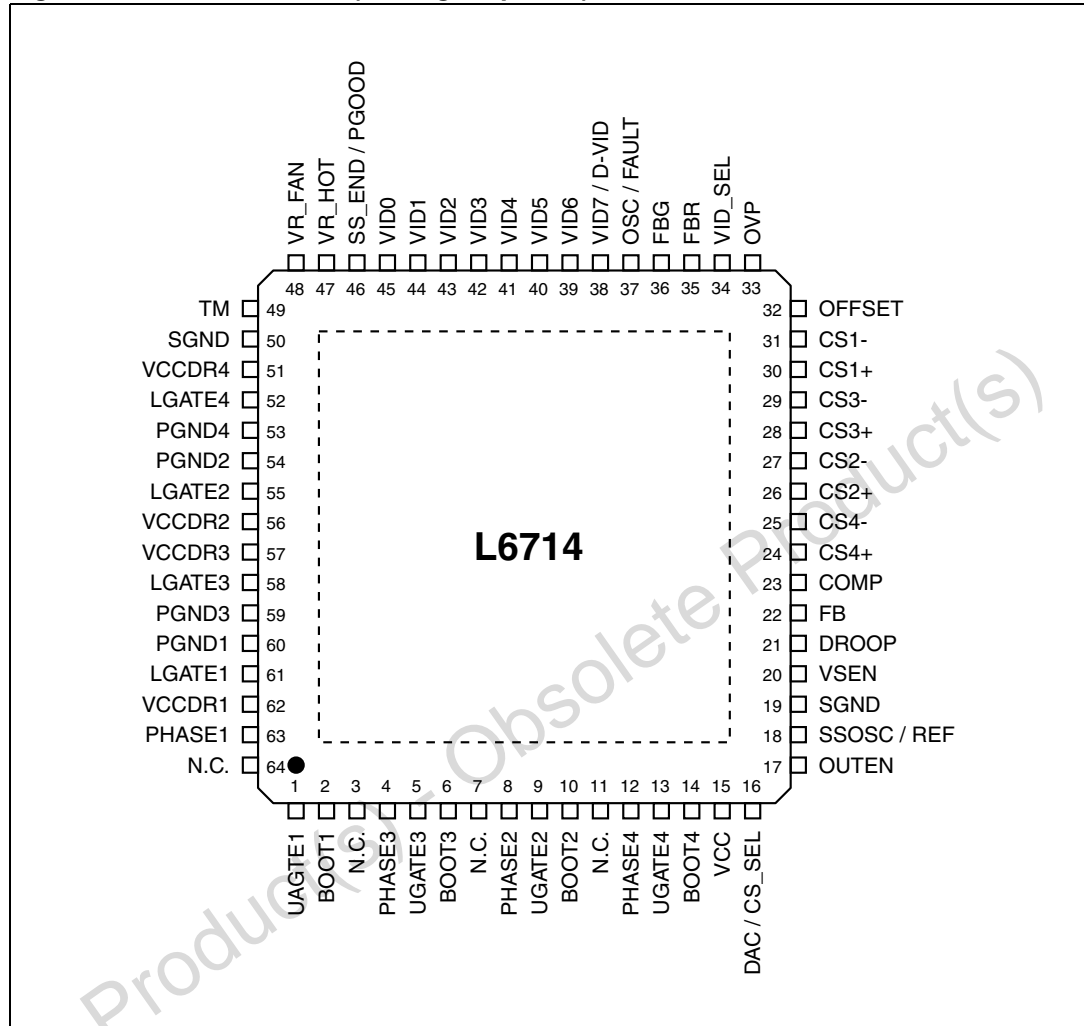

2.2 Functions

Table 1. Pin functions

N°	Pin	Function
1	UGATE1	Channel 1 HS driver output. A small series resistors helps in reducing device-dissipated power.
2	BOOT1	Channel 1 HS driver supply. Connect through a capacitor (100nF typ.) to PHASE1 and provide necessary Bootstrap diode. A small resistor in series to the boot diode helps in reducing Boot capacitor overcharge.
3	N.C.	Not internally connected.
4	PHASE3	Channel 3 HS driver return path. It must be connected to the HS3 mosfet source and provides return path for the HS driver of channel 3.
5	UGATE3	Channel 3 HS driver output. A small series resistors helps in reducing device-dissipated power.
6	BOOT3	Channel 3 HS driver supply. Connect through a capacitor (100nF typ.) to PHASE3 and provide necessary Bootstrap diode. A small resistor in series to the boot diode helps in reducing Boot capacitor overcharge.
7	N.C.	Not internally connected.
8	PHASE2	Channel 2 HS driver return path. It must be connected to the HS2 mosfet source and provides return path for the HS driver of channel 2.
9	UGATE2	Channel 2 HS driver output. A small series resistors helps in reducing device-dissipated power.
10	BOOT2	Channel 2 HS driver supply. Connect through a capacitor (100nF typ.) to PHASE2 and provide necessary Bootstrap diode. A small resistor in series to the boot diode helps in reducing Boot capacitor overcharge.
11	N.C.	Not internally connected.
12	PHASE4	Channel 4 HS driver return path. It must be connected to the HS4 mosfet source and provides return path for the HS driver of channel 4.
13	UGATE4	Channel 4 HS driver output. A small series resistors helps in reducing device-dissipated power.
14	BOOT4	Channel 4 HS driver supply. Connect through a capacitor (100nF typ.) to PHASE4 and provide necessary Bootstrap diode. A small resistor in series to the boot diode helps in reducing Boot capacitor overcharge.

Table 1. Pin functions

N°	Pin	Function
15	VCC	Device supply voltage. The operative voltage is $12V \pm 15\%$. Filter with $1\mu F$ (typ) MLCC vs. SGND.
16	DAC/ CS_SEL	<u>D</u> AC and <u>C</u> urrent <u>S</u> ense <u>S</u> Election Pin. This pin sources a constant $12.5\mu A$ current. By connecting a resistor vs. SGND it is possible to select between Intel and AMD integrated DACs and Current Sense methods. Filter with $100pF$ (max) vs. SGND. DACs and Current Sense methods cannot be changed dynamically. See "DAC selection" Section and See Table 10 for details.
17	OUTEN	<u>O</u> UTput <u>E</u> Nable Pin. Forced low, the device stops operations with all MOSFET OFF: all the protections are disabled except for Section 16.2: Preliminary over voltage on page 47 . Set free, the device starts-up implementing soft-start up to the selected VID code. Cycle this pin to recover latch from protections; filter with $1nF$ (typ) vs. SGND.
18	SSOSC/ REF	Intel Mode. <u>S</u> oft <u>S</u> tart <u>O</u> SCillator Pin. By connecting a resistor R_{SSOSC} vs. SGND, it allows programming the frequency F_{SS} of an internal additional oscillator that drives the reference during Soft-Start. Setting this frequency allows programming the Soft-Start time T_{SS} proportionally to the R_{SSOSC} connected with a gain of $20.1612 [\mu s / k\Omega]$. The same slope implemented to reach V_{BOOT} has to be considered also when the reference moves from V_{BOOT} to the programmed VID code. See "Soft start" Section for details. AMD Mode. <u>R</u> Eference Output. Filter with $47\Omega - 4.7nF$ vs. SGND.
19	SGND	All the internal references are referred to this pin. Connect to the PCB Signal Ground.
20	VSEN	Remote Buffer Output, it manages OVP and UVP protections and PGOOD (when applicable). See "Output voltage monitor and protections" Section and See Table 10 for details.
21	DROOP	A current proportional to the total current read is sourced from this pin according to the Current Reading Gain. Short to FB to implement Droop Function or Short to SGND to disable the function. Connecting to SGND through a resistor and filtering with a capacitor, the current info can be used for other purposes. See "Droop function (Optional)" Section
22	FB	Error Amplifier Inverting Input. Connect with a resistor R_{FB} vs. VSEN and with an $R_F - C_F$ vs. COMP.
23	COMP	Error Amplifier Output. Connect with an $R_F - C_F$ vs. FB. The device cannot be disabled by pulling down this pin.
24	CS4+	Channel 4 Current Sense Positive Input. LS Mosfet Sense: connect through a resistor R_g to the LS mosfet Source. Inductor DCR Sense: connect through an R-C filter to the phase-side of the channel 4 inductor. See "Layout guidelines" Section for proper layout of this connection.

Table 1. Pin functions

N°	Pin	Function
25	CS4-	Channel 4 Current Sense Negative Input. LS Mosfet Sense: connect through a resistor R_g to the LS mosfet Drain. Inductor DCR Sense: connect through a R_g resistor to the output-side of the channel 4 inductor. See "Layout guidelines" Section for proper layout of this connection.
26	CS2+	Channel 2 Current Sense Positive Input. LS Mosfet Sense: connect through a resistor R_g to the LS mosfet Source. Inductor DCR Sense: connect through an R-C filter to the phase-side of the channel 2 inductor. See "Layout guidelines" Section for proper layout of this connection.
27	CS2-	Channel 2 Current Sense Negative Input. LS Mosfet Sense: connect through a resistor R_g to the LS mosfet Drain. Inductor DCR Sense: connect through a R_g resistor to the output-side of the channel 2 inductor. See "Layout guidelines" Section for proper layout of this connection.
28	CS3+	Channel 3 Current Sense Positive Input. LS Mosfet Sense: connect through a resistor R_g to the LS mosfet Source. Inductor DCR Sense: connect through an R-C filter to the phase-side of the channel 3 inductor. See "Layout guidelines" Section for proper layout of this connection.
29	CS3-	Channel 3 Current Sense Negative Input. LS Mosfet Sense: connect through a resistor R_g to the LS mosfet Drain. Inductor DCR Sense: connect through a R_g resistor to the output-side of the channel 3 inductor. See "Layout guidelines" Section for proper layout of this connection.
30	CS1+	Channel 1 Current Sense Positive Input. LS Mosfet Sense: connect through a resistor R_g to the LS mosfet Source. Inductor DCR Sense: connect through an R-C filter to the phase-side of the channel 1 inductor. See "Layout guidelines" Section for proper layout of this connection.
31	CS1-	Channel 1 Current Sense Negative Input. LS Mosfet Sense: connect through a resistor R_g to the LS mosfet Drain. Inductor DCR Sense: connect through a R_g resistor to the output-side of the channel 1 inductor. See "Layout guidelines" Section for proper layout of this connection.
32	OFFSET	Offset Programming Pin. Internally fixed at 1.240V, connecting a R_{OFFSET} resistor vs. SGND allows setting a current that is mirrored into FB pin in order to program a positive offset according to the selected R_{FB} . Short to SGND to disable the function. See "Offset (Optional)" Section for details.

Table 1. Pin functions

N°	Pin	Function
33	OVP	Over Voltage Programming Pin. Internally pulled up by 12.5µA(typ) to 5V. Set free to use built-in protection thresholds as reported into Table 10 . Connect to SGND through a R _{OVP} resistor and filter with 100pF (max) to set the OVP threshold to a fixed voltage according to the R _{OVP} resistor. See "Over voltage and programmable OVP" Section for details.
34	VID_SEL	Intel Mode. It allows selecting between VR10 (short to SGND, Table 7) or VR11 (floating, Table 6) DACs ,internally pulled up by 12.5µA (typ).. See "Configuring the device" Section for details. AMD Mode. Not Applicable. Needs to be shorted to SGND.
35	FBR	Remote Buffer Non Inverting Input. Connect to the positive side of the load to perform remote sense. See "Layout guidelines" Section for proper layout of this connection.
36	FBG	Remote Buffer Inverting Input. Connect to the negative side of the load to perform remote sense. See "Layout guidelines" Section for proper layout of this connection.
37	OSC/ FAULT	Oscillator Pin. It allows programming the switching frequency F _{SW} of each channel: the equivalent switching frequency at the load side results in being multiplied by the phase number N. Frequency is programmed according to the resistor connected from the pin vs. SGND or VCC with a gain of 6kHz/µA (see relevant section for details). Leaving the pin floating programs a switching frequency of 150kHz per phase. The pin is forced high (5V) to signal an OVP FAULT: to recover from this condition, cycle VCC or the OUTEN pin. See "Oscillator" Section for details.
38	VID7/ DVID	VID7 - Intel Mode. See VID5 to VID0 Section. DVID - AMD Mode. DVID Output. CMOS output pulled high when the controller is performing a D-VID transition (with 32 clock cycle delay after the transition has finished). See "Dynamic VID transitions" Section for details.
39	VID6	Intel Mode. See VID5 to VID0 Section. AMD Mode. Not Applicable. Need to be shorted to SGND.
40 to 45	VID5 to VID0	Intel Mode. Voltage IDentification Pins (also applies to VID6, VID7). Internally pulled up by 25µA to 5V, connect to SGND to program a '0' or leave floating to program a '1'. They allow programming output voltage as specified in Table 6 and Table 7 according to VID_SEL status. OVP and UVP protection comes as a consequence of the programmed code (See Table 10). AMD Mode. Voltage IDentification Pins. Internally pulled down by 12.5µA, leave floating to program a '0' while pull up to more than 1.4V to program a '1'. They allow programming the output voltage as specified in Table 9 on page 21 (VID7 doesn't care). OVP and UVP protection comes as a consequence of the programmed code (See Table 10). Note. VID6 not used, need to be shorted to SGND.

Table 1. Pin functions

N°	Pin	Function
46	SS_END/ PGOOD	SSEND - Intel Mode. Soft Start <u>END</u> Signal. Open Drain Output set free after SS has finished and pulled low when triggering any protection. Pull up to a voltage lower than 5V (typ), if not used it can be left floating. PGOOD - AMD Mode. Open Drain Output set free after SS has finished and pulled low when VSEN is lower than the relative threshold. Pull up to a voltage lower than 5V (typ), if not used it can be left floating.
47	VR_HOT	<u>V</u> oltage <u>R</u> egulator <u>H</u> OT. Over Temperature Alarm Signal. Open Drain Output, set free when TM overcomes the Alarm Threshold. Thermal Monitoring Output enabled if $V_{CC} > UVLO_{VCC}$. See "Thermal monitor" Section for details and typical connections.
48	VR_FAN	<u>V</u> oltage <u>R</u> egulator <u>F</u> AN. Over Temperature Warning Signal. Open Drain Output, set free when TM overcomes the Warning Threshold. Thermal Monitoring Output enabled if $V_{CC} > UVLO_{VCC}$. See "Thermal monitor" Section for details and typical connections.
49	TM	<u>T</u> hermal <u>M</u> onitor Input. It senses the regulator temperature through apposite network and drives VR_FAN and VR_HOT accordingly. Short TM pin to SGND if not used. See "Thermal monitor" Section for details and typical connections.
50	SGND	All the internal references are referred to this pin. Connect to the PCB Signal Ground.
51	VCCDR4	Channel 4 LS Driver Supply. It must be connected to others VCCDRx pins. LS Driver supply can range from 5Vbus up to 12Vbus, filter with 1μF MLCC cap vs. PGND4.
52	LGATE4	Channel 4 LS Driver Output. A small series resistor helps in reducing device-dissipated power.
53	PGND4	Channel 4 LS Driver return path. Connect to Power ground Plane.
54	PGND2	Channel 2 LS Driver return path. Connect to Power ground Plane.
55	LGATE2	Channel 2 LS Driver Output. A small series resistor helps in reducing device-dissipated power.
56	VCCDR2	Channel 2 LS Driver Supply. It must be connected to others VCCDRx pins. LS Driver supply can range from 5Vbus up to 12Vbus, filter with 1μF MLCC cap vs. PGND2.
57	VCCDR3	Channel 3 LS Driver Supply. It must be connected to others VCCDRx pins. LS Driver supply can range from 5Vbus up to 12Vbus, filter with 1μF MLCC cap vs. PGND3.
58	LGATE3	Channel 3 LS Driver Output. A small series resistor helps in reducing device-dissipated power.
59	PGND3	Channel 3 LS Driver return path. Connect to Power ground Plane.

Table 1. Pin functions

N°	Pin	Function
60	PGND1	Channel 1 LS Driver return path. Connect to Power ground Plane.
61	LGATE1	Channel 1 LS Driver Output. A small series resistor helps in reducing device-dissipated power.
62	VCCDR1	Channel 1 LS Driver Supply. It must be connected to others VCCDRx pins. LS Driver supply can range from 5Vbus up to 12Vbus, filter with 1µF MLCC cap vs. PGND1.
63	PHASE1	Channel 1 HS driver return path. It must be connected to the HS1 mosfet source and provides return path for the HS driver of channel 1.
64	N.C.	Not internally connected.
PAD	THERMAL PAD	Thermal pad connects the Silicon substrate and makes good thermal contact with the PCB to dissipate the power necessary to drive the external mosfets. Connect to the PGND plane with several VIAs to improve thermal conductivity.

3 Electrical data

3.1 Maximum rating

Table 2. Absolute maximum ratings

Symbol	Parameter	Value	Unit
V_{CC}, V_{CCDRx}	to PGNDx	15	V
$V_{BOOTx} - V_{PHASEx}$	Boot voltage	15	V
$V_{UGATEx} - V_{PHASEx}$		15	V
$V_{CC} - V_{BOOTx}$		7.5	V
	LGATEx, PHASEx, to PGNDx	-0.3 to $V_{CC} + 0.3$	V
	VID0 to VID7, VID_SEL	-0.3 to 5	V
	All other Pins to PGNDx	-0.3 to 7	V
V_{PHASEx}	Static condition To PGNDx, $V_{CC}=14V$, $BOOTx=7V$, $PHASEx=-7.5V$	-7.5	V
	Positive peak voltage to PGNDx; $T < 20ns @ 600kHz$	26	V

3.2 Thermal data

Table 3. Thermal data

Symbol	Parameter	Value	Unit
R_{thJA}	Thermal resistance junction to ambient (Device soldered on 2s2p PC Board)	40	°C/W
T_{MAX}	Maximum junction temperature	150	°C
T_{STG}	Storage temperature range	-40 to 150	°C
T_J	Junction temperature range	0 to 125	°C
P_{TOT}	Maximum power dissipation at $T_A = 25^\circ C$	2.5	W

4 Electrical characteristics

$V_{CC} = 12V \pm 15\%$, $T_J = 0^\circ C$ to $70^\circ C$, unless otherwise specified

Table 4. Electrical characteristics

Symbol	Parameter	Test condition	Min.	Typ.	Max.	Unit
Supply Current						
I_{CC}	VCC supply current	HGATE _x and LGATE _x = OPEN VCCDR _x = BOOT _x = 12V		17		mA
I_{CCDRx}	VCCDR _x supply current	LGATE _x = OPEN; VCCDR _x = 12V		1		mA
I_{BOOTx}	BOOT _x supply current	HGATE _x = OPEN; PHASE _x to PGND _x ; VCC = BOOT _x = 12V		0.75		mA
Power-ON						
UVLO _{VCC}	VCC turn-ON	VCC Rising; VCCDR _x = 5V		8.9	9.3	V
	VCC turn-OFF	VCC Falling; VCCDR _x = 5V	7.3	7.7		V
UVLO _{VCCDR}	VCCDR turn-ON	VCCDR _x Rising; VCC = 12V		4.5	4.8	V
	VCCDR turn-OFF	VCCDR _x Falling; VCC = 12V	3.9	4.3		V
UVLO _{OVP}	Pre-OVP turn-ON	VCC Rising; VCCDR _x = 5V		3.6	3.85	V
	Pre-OVP turn-OFF	VCC Falling; VCCDR _x = 5V	3.05	3.3		V
Oscillator and Inhibit						
F_{OSC}	Main Oscillator Accuracy	OSC = OPEN OSC = OPEN; $T_J = 0^\circ C$ to $125^\circ C$	135 130	150	165 170	kHz
T_1	SS Delay Time	Intel mode	1			ms
T_2	SS Time T_2	Intel mode; $R_{SSOSC} = 25k\Omega$		500		μs
T_3	SS Time T_3	Intel mode	50			μs
OUTEN	Output enable intel mode	Rising thresholds voltage	0.80	0.85	0.90	V
		Hysteresis		100		mV
	Output enable AMD mode	Input low			0.80	V
		Input high	1.40			V
	Pull-up current			12.5		μA
d_{MAX}	Maximum duty cycle	OSC = OPEN; $I_{DROOP} = 0\mu A$		80		%
		OSC = OPEN; $I_{DROOP} = 140\mu A$		40		%
ΔV_{OSC}	PWM _x ramp amplitude			4		V
FAULT	Voltage at Pin OSC	OVP Active		5		V

Table 4. Electrical characteristics

Symbol	Parameter	Test condition	Min.	Typ.	Max.	Unit
Reference and DAC						
k_{VID}	Output voltage accuracy	Intel mode VID = 1.000V to VID = 1.600V FBR = VOUT; FBG = GNDOUT	-0.5	-	0.5	%
		AMD mode VID=1.000V to VID = 1.550V FBR = VOUT; FBG = GNDOUT	-0.6	-	0.6	%
REF	Reference accuracy	AMD mode; respect VID	-10	-	10	mV
V_{BOOT}	Boot voltage	Intel mode		1.081		V
I_{VID}	VID Pull-up current	Intel mode; VIDx to SGND		25		μ A
	VID Pull-down current	AMD mode; VIDx to 5.4V		12.5		μ A
VID_{IL}	VID thresholds	Intel mode; Input Low AMD mode; Input Low			0.3 0.8	V
VID_{IH}		Intel mode; Input High AMD mode; Input High	0.8 1.35			V
VID_{SEL}	VID_SEL threshold (Intel mode)	Input low Input high	0.8		0.3	V
Error amplifier and remote buffer						
A_0	EA DC gain			80		dB
SR	EA slew rate	COMP = 10pF to SGND		20		V/ μ s
	RB DC gain			1		V/V
CMRR	Remote buffer common mode rejection ratio			40		dB
Differential current sensing and offset						
I_{CSx+}	Bias current	LS sense Inductor sense		25 0		μ A
$\frac{I_{INFOx} - I_{AVG}}{I_{AVG}}$	Current sense mismatch	$R_g = 1k\Omega$; $I_{INFOx} = 25\mu A$	-3	-	3	%
I_{OCTH}	Over current threshold	$I_{CSx-}(OCP) - I_{CSx-}(0)$	30	35	40	μ A
k_{IDROOP}	Droop current deviation from nominal value	OFFSET = SGND; $R_g = 1k\Omega$ $I_{DROOP} = 0$ to $80\mu A$;	-2	-	2	μ A
$K_{I\text{OFFSET}}$	Offset current accuracy	$I_{\text{OFFSET}} = 50\mu A$ to $250\mu A$	-8	-	8	%
I_{OFFSET}	OFFSET current range		0		250	μ A
V_{OFFSET}	OFFSET pin bias	$I_{\text{OFFSET}} = 0$ to $250\mu A$		1.240		V

Table 4. Electrical characteristics

Symbol	Parameter	Test condition	Min.	Typ.	Max.	Unit
Gate drivers						
t_{RISE_UGATEx}	HS rise time	BOOTx - PHASEx = 10V; C _{UGATEx} to PHASEx = 3.3nF		15	30	ns
I _{UGATEx}	HS source current	BOOTx - PHASEx = 10V		2		A
R _{UGATEx}	HS sink resistance	BOOTx - PHASEx = 12V	1.5	2	2.5	Ω
t_{RISE_LGATEx}	LS rise time	VCCDRx = 10V; C _{LGATEx} to PGNDx = 5.6nF		30	55	ns
I _{LGATEx}	LS source current	VCCDRx = 10V		1.8		A
R _{LGATEx}	LS sink resistance	VCCDRx = 12V	0.7	1.1	1.5	Ω
Protections						
OVP	Over voltage protection (VSEN Rising)	Intel mode; before V _{BOOT}			1.300	V
		Intel mode; above VID	100	150	200	mV
		AMD mode	1.700	1.740	1.780	V
Program-mable OVP	I _{OVP} current	OVP = SGND	11.5	12.5	13.5	μA
	Comparator offset voltage	OVP = 1.8V	-50	0	50	mV
Pre-OVP	Preliminary over voltage protection	UVLO _{OVP} < VCC < UVLO _{VCC} VCC > UVLO _{VCC} & OUTEN = SGND		1.800		V
		Hysteresis		350		mV
UVP	Under voltage protection	VSEN falling; below VID		-750		mV
PGOOD	PGOOD threshold	AMD mode; VSEN falling; below VID		-300		mV
V _{SSEND/PGOOD}	SSEND / PGOOD Voltage low	I = -4mA			0.4	V
Thermal Monitor						
V _{TM}	TM Warning (VR_FAN)	V _{TM} rising		3.2		V
	TM Alarm (VR_HOT)	V _{TM} rising		3.6		V
	TM Hysteresis			100		mV
V _{VR_HOT} ; V _{VR_FAN}	VR_HOT voltage low;	I = -4mA			0.4	V
	VR_FAN voltage low				0.4	V

5 VID Tables

5.1 Mapping for the Intel VR11 mode

Table 5. Voltage Identification (VID) Mapping for Intel VR11 Mode

VID7	VID6	VID5	VID4	VID3	VID2	VID1	VID0
800mV	400mV	200mV	100mV	50mV	25mV	12.5mV	6.25mV

5.2 Voltage Identification (VID) for Intel VR11 mode

Table 6. Voltage Identification (VID) for Intel VR11 mode (See Note).

HEX Code		Output voltage (1)	HEX Code		Output voltage (1)	HEX Code		Output voltage (1)	HEX Code		Output voltage (1)
0	0	OFF	4	0	1.21250	8	0	0.81250	C	0	0.41250
0	1	OFF	4	1	1.20625	8	1	0.80625	C	1	0.40625
0	2	1.60000	4	2	1.20000	8	2	0.80000	C	2	0.40000
0	3	1.59375	4	3	1.19375	8	3	0.79375	C	3	0.39375
0	4	1.58750	4	4	1.18750	8	4	0.78750	C	4	0.38750
0	5	1.58125	4	5	1.18125	8	5	0.78125	C	5	0.38125
0	6	1.57500	4	6	1.17500	8	6	0.77500	C	6	0.37500
0	7	1.56875	4	7	1.16875	8	7	0.76875	C	7	0.36875
0	8	1.56250	4	8	1.16250	8	8	0.76250	C	8	0.36250
0	9	1.55625	4	9	1.15625	8	9	0.75625	C	9	0.35625
0	A	1.55000	4	A	1.15000	8	A	0.75000	C	A	0.35000
0	B	1.54375	4	B	1.14375	8	B	0.74375	C	B	0.34375
0	C	1.53750	4	C	1.13750	8	C	0.73750	C	C	0.33750
0	D	1.53125	4	D	1.13125	8	D	0.73125	C	D	0.33125
0	E	1.52500	4	E	1.12500	8	E	0.72500	C	E	0.32500
0	F	1.51875	4	F	1.11875	8	F	0.71875	C	F	0.31875
1	0	1.51250	5	0	1.11250	9	0	0.71250	D	0	0.31250
1	1	1.50625	5	1	1.10625	9	1	0.70625	D	1	0.30625
1	2	1.50000	5	2	1.10000	9	2	0.70000	D	2	0.30000
1	3	1.49375	5	3	1.09375	9	3	0.69375	D	3	0.29375
1	4	1.48750	5	4	1.08750	9	4	0.68750	D	4	0.28750
1	5	1.48125	5	5	1.08125	9	5	0.68125	D	5	0.28125
1	6	1.47500	5	6	1.07500	9	6	0.67500	D	6	0.27500

Table 6. Voltage Identification (VID) for Intel VR11 mode (See Note).

HEX Code		Output voltage (1)	HEX Code		Output voltage (1)	HEX Code		Output voltage (1)	HEX Code		Output voltage (1)
1	7	1.46875	5	7	1.06875	9	7	0.66875	D	7	0.26875
1	8	1.46250	5	8	1.06250	9	8	0.66250	D	8	0.26250
1	9	1.45625	5	9	1.05625	9	9	0.65625	D	9	0.25625
1	A	1.45000	5	A	1.05000	9	A	0.65000	D	A	0.25000
1	B	1.44375	5	B	1.04375	9	B	0.64375	D	B	0.24375
1	C	1.43750	5	C	1.03750	9	C	0.63750	D	C	0.23750
1	D	1.43125	5	D	1.03125	9	D	0.63125	D	D	0.23125
1	E	1.42500	5	E	1.02500	9	E	0.62500	D	E	0.22500
1	F	1.41875	5	F	1.01875	9	F	0.61875	D	F	0.21875
2	0	1.41250	6	0	1.01250	A	0	0.61250	E	0	0.21250
2	1	1.40625	6	1	1.00625	A	1	0.60625	E	1	0.20625
2	2	1.40000	6	2	1.00000	A	2	0.60000	E	2	0.20000
2	3	1.39375	6	3	0.99375	A	3	0.59375	E	3	0.19375
2	4	1.38750	6	4	0.98750	A	4	0.58750	E	4	0.18750
2	5	1.38125	6	5	0.98125	A	5	0.58125	E	5	0.18125
2	6	1.37500	6	6	0.97500	A	6	0.57500	E	6	0.17500
2	7	1.36875	6	7	0.96875	A	7	0.56875	E	7	0.16875
2	8	1.36250	6	8	0.96250	A	8	0.56250	E	8	0.16250
2	9	1.35625	6	9	0.95625	A	9	0.55625	E	9	0.15625
2	A	1.35000	6	A	0.95000	A	A	0.55000	E	A	0.15000
2	B	1.34375	6	B	0.94375	A	B	0.54375	E	B	0.14375
2	C	1.33750	6	C	0.93750	A	C	0.53750	E	C	0.13750
2	D	1.33125	6	D	0.93125	A	D	0.53125	E	D	0.13125
2	E	1.32500	6	E	0.92500	A	E	0.52500	E	E	0.12500
2	F	1.31875	6	F	0.91875	A	F	0.51875	E	F	0.11875
3	0	1.31250	7	0	0.91250	B	0	0.51250	F	0	0.11250
3	1	1.30625	7	1	0.90625	B	1	0.50625	F	1	0.10625
3	2	1.30000	7	2	0.90000	B	2	0.50000	F	2	0.10000
3	3	1.29375	7	3	0.89375	B	3	0.49375	F	3	0.09375
3	4	1.28750	7	4	0.88750	B	4	0.48750	F	4	0.08750
3	5	1.28125	7	5	0.88125	B	5	0.48125	F	5	0.08125
3	6	1.27500	7	6	0.87500	B	6	0.47500	F	6	0.07500
3	7	1.26875	7	7	0.86875	B	7	0.46875	F	7	0.06875

Table 6. Voltage Identification (VID) for Intel VR11 mode (See Note).

HEX Code		Output voltage (1)	HEX Code		Output voltage (1)	HEX Code		Output voltage (1)	HEX Code		Output voltage (1)
3	8	1.26250	7	8	0.86250	B	8	0.46250	F	8	0.06250
3	9	1.25625	7	9	0.85625	B	9	0.45625	F	9	0.05625
3	A	1.25000	7	A	0.85000	B	A	0.45000	F	A	0.05000
3	B	1.24375	7	B	0.84375	B	B	0.44375	F	B	0.04375
3	C	1.23750	7	C	0.83750	B	C	0.43750	F	C	0.03750
3	D	1.23125	7	D	0.83125	B	D	0.43125	F	D	0.03125
3	E	1.22500	7	E	0.82500	B	E	0.42500	F	E	OFF
3	F	1.21875	7	F	0.81875	B	F	0.41875	F	F	OFF

1. According to VR11 specs, the device automatically regulates output voltage 19mV lower to avoid any external offset to modify the built-in 0.5% accuracy improving TOB performances. Output regulated voltage is than what extracted from the table lowered by 19mV built-in offset.

5.3 Voltage Identifications (VID) for Intel VR10 mode + 6.25mV

(VID7 does not care)

Table 7. Voltage identifications (VID) for Intel VR10 mode + 6.25mV (See Note).

VID 4	VID 3	VID 2	VID 1	VID 0	VID 5	VID 6	Output voltage (1)	VID 4	VID 3	VID 2	VID 1	VID 0	VID 5	VID 6	Output voltage (1)
0	1	0	1	0	1	1	1.60000	1	1	0	1	0	1	1	1.20000
0	1	0	1	0	1	0	1.59375	1	1	0	1	0	1	0	1.19375
0	1	0	1	1	0	1	1.58750	1	1	0	1	1	0	1	1.18750
0	1	0	1	1	0	0	1.58125	1	1	0	1	1	0	0	1.18125
0	1	0	1	1	1	1	1.57500	1	1	0	1	1	1	1	1.17500
0	1	0	1	1	1	0	1.56875	1	1	0	1	1	1	0	1.16875
0	1	1	0	0	0	1	1.56250	1	1	1	0	0	0	1	1.16250
0	1	1	0	0	0	0	1.55625	1	1	1	0	0	0	0	1.15625
0	1	1	0	0	1	1	1.55000	1	1	1	0	0	1	1	1.15000
0	1	1	0	0	1	0	1.54375	1	1	1	0	0	1	0	1.14375
0	1	1	0	1	0	1	1.53750	1	1	1	0	1	0	1	1.13750
0	1	1	0	1	0	0	1.53125	1	1	1	0	1	0	0	1.13125
0	1	1	0	1	1	1	1.52500	1	1	1	0	1	1	1	1.12500
0	1	1	0	1	1	0	1.51875	1	1	1	0	1	1	0	1.11875
0	1	1	1	0	0	1	1.51250	1	1	1	1	0	0	1	1.11250
0	1	1	1	0	0	0	1.50625	1	1	1	1	0	0	0	1.10625

Table 7. Voltage identifications (VID) for Intel VR10 mode + 6.25mV (See Note).

VID 4	VID 3	VID 2	VID 1	VID 0	VID 5	VID 6	Output voltage (1)	VID 4	VID 3	VID 2	VID 1	VID 0	VID 5	VID 6	Output voltage (1)
0	1	1	1	0	1	1	1.50000	1	1	1	1	0	1	1	1.10000
0	1	1	1	0	1	0	1.49375	1	1	1	1	0	1	0	1.09375
0	1	1	1	1	0	1	1.48750	1	1	1	1	1	0	1	OFF
0	1	1	1	1	0	0	1.48125	1	1	1	1	1	0	0	OFF
0	1	1	1	1	1	1	1.47500	1	1	1	1	1	1	1	OFF
0	1	1	1	1	1	0	1.46875	1	1	1	1	1	1	0	OFF
1	0	0	0	0	0	1	1.46250	0	0	0	0	0	0	1	1.08750
1	0	0	0	0	0	0	1.45625	0	0	0	0	0	0	0	1.08125
1	0	0	0	0	1	1	1.45000	0	0	0	0	0	1	1	1.07500
1	0	0	0	0	1	0	1.44375	0	0	0	0	0	1	0	1.06875
1	0	0	0	1	0	1	1.43750	0	0	0	0	1	0	1	1.06250
1	0	0	0	1	0	0	1.43125	0	0	0	0	1	0	0	1.05625
1	0	0	0	1	1	1	1.42500	0	0	0	0	1	1	1	1.05000
1	0	0	0	1	1	0	1.41875	0	0	0	0	1	1	0	1.04375
1	0	0	1	0	0	1	1.41250	0	0	0	1	0	0	1	1.03750
1	0	0	1	0	0	0	1.40625	0	0	0	1	0	0	0	1.03125
1	0	0	1	0	1	1	1.40000	0	0	0	1	0	1	1	1.02500
1	0	0	1	0	1	0	1.39375	0	0	0	1	0	1	0	1.01875
1	0	0	1	1	0	1	1.38750	0	0	0	1	1	0	1	1.01250
1	0	0	1	1	0	0	1.38125	0	0	0	1	1	0	0	1.00625
1	0	0	1	1	1	1	1.37500	0	0	0	1	1	1	1	1.00000
1	0	0	1	1	1	0	1.36875	0	0	0	1	1	1	0	0.99375
1	0	1	0	0	0	1	1.36250	0	0	1	0	0	0	1	0.98750
1	0	1	0	0	0	0	1.35625	0	0	1	0	0	0	0	0.98125
1	0	1	0	0	1	1	1.35000	0	0	1	0	0	1	1	0.97500
1	0	1	0	0	1	0	1.34375	0	0	1	0	0	1	0	0.96875
1	0	1	0	1	0	1	1.33750	0	0	1	0	1	0	1	0.96250
1	0	1	0	1	0	0	1.33125	0	0	1	0	1	0	0	0.95625
1	0	1	0	1	1	1	1.32500	0	0	1	0	1	1	1	0.95000
1	0	1	0	1	1	0	1.31875	0	0	1	0	1	1	0	0.94375
1	0	1	1	0	0	1	1.31250	0	0	1	1	0	0	1	0.93750
1	0	1	1	0	0	0	1.30625	0	0	1	1	0	0	0	0.93125
1	0	1	1	0	1	1	1.30000	0	0	1	1	0	1	1	0.92500

Table 7. Voltage identifications (VID) for Intel VR10 mode + 6.25mV (See Note).

VID 4	VID 3	VID 2	VID 1	VID 0	VID 5	VID 6	Output voltage (1)	VID 4	VID 3	VID 2	VID 1	VID 0	VID 5	VID 6	Output voltage (1)
1	0	1	1	0	1	0	1.29375	0	0	1	1	0	1	0	0.91875
1	0	1	1	1	0	1	1.28750	0	0	1	1	1	0	1	0.91250
1	0	1	1	1	0	0	1.28125	0	0	1	1	1	0	0	0.90625
1	0	1	1	1	1	1	1.27500	0	0	1	1	1	1	1	0.90000
1	0	1	1	1	1	0	1.26875	0	0	1	1	1	1	0	0.89375
1	1	0	0	0	0	1	1.26250	0	1	0	0	0	0	1	0.88750
1	1	0	0	0	0	0	1.25625	0	1	0	0	0	0	0	0.88125
1	1	0	0	0	1	1	1.25000	0	1	0	0	0	1	1	0.87500
1	1	0	0	0	1	0	1.24375	0	1	0	0	0	1	0	0.86875
1	1	0	0	1	0	1	1.23750	0	1	0	0	1	0	1	0.86250
1	1	0	0	1	0	0	1.23125	0	1	0	0	1	0	0	0.85625
1	1	0	0	1	1	1	1.22500	0	1	0	0	1	1	1	0.85000
1	1	0	0	1	1	0	1.21875	0	1	0	0	1	1	0	0.84375
1	1	0	1	0	0	1	1.21250	0	1	0	1	0	0	1	0.83750
1	1	0	1	0	0	0	1.20625	0	1	0	1	0	0	0	0.83125

1. According to VR10.x specs, the device automatically regulates output voltage 19mV lower to avoid any external offset to modify the built-in 0.5% accuracy improving TOB performances. Output regulated voltage is than what extracted from the table lowered by 19mV built-in offset. VID7 doesn't care.

5.4 Mapping for the AMD 6BIT mode

Table 8. Voltage identifications (VID) mapping for AMD 6BIT mode

VID4	VID3	VID2	VID1	VID0
400mV	200mV	100mV	50mV	25mV

5.5 Voltage identifications (VID) codes for AMD 6BIT mode

Table 9. Voltage identifications (VID) codes for AMD 6BIT mode (See Note).

VID 5	VID 4	VID 3	VID 2	VID 1	VID 0	Output Voltage (1)	VID 5	VID 4	VID 3	VID 2	VID 1	VID 0	Output Voltage (1)
0	0	0	0	0	0	1.5500	1	0	0	0	0	0	0.7625
0	0	0	0	0	1	1.5250	1	0	0	0	0	1	0.7500
0	0	0	0	1	0	1.5000	1	0	0	0	1	0	0.7375
0	0	0	0	1	1	1.4750	1	0	0	0	1	1	0.7250

Table 9. Voltage identifications (VID) codes for AMD 6BIT mode (See Note).

VID 5	VID 4	VID 3	VID 2	VID 1	VID 0	Output Voltage (1)	VID 5	VID 4	VID 3	VID 2	VID 1	VID 0	Output Voltage (1)
0	0	0	1	0	0	1.4500	1	0	0	1	0	0	0.7125
0	0	0	1	0	1	1.4250	1	0	0	1	0	1	0.7000
0	0	0	1	1	0	1.4000	1	0	0	1	1	0	0.6875
0	0	0	1	1	1	1.3750	1	0	0	1	1	1	0.6750
0	0	1	0	0	0	1.3500	1	0	1	0	0	0	0.6625
0	0	1	0	0	1	1.3250	1	0	1	0	0	1	0.6500
0	0	1	0	1	0	1.3000	1	0	1	0	1	0	0.6375
0	0	1	0	1	1	1.2750	1	0	1	0	1	1	0.6250
0	0	1	1	0	0	1.2500	1	0	1	1	0	0	0.6125
0	0	1	1	0	1	1.2250	1	0	1	1	0	1	0.6000
0	0	1	1	1	0	1.2000	1	0	1	1	1	0	0.5875
0	0	1	1	1	1	1.1750	1	0	1	1	1	1	0.5750
0	1	0	0	0	0	1.1500	1	1	0	0	0	0	0.5625
0	1	0	0	0	1	1.1250	1	1	0	0	0	1	0.5500
0	1	0	0	1	0	1.1000	1	1	0	0	1	0	0.5375
0	1	0	0	1	1	1.0750	1	1	0	0	1	1	0.5250
0	1	0	1	0	0	1.0500	1	1	0	1	0	0	0.5125
0	1	0	1	0	1	1.0250	1	1	0	1	0	1	0.5000
0	1	0	1	1	0	1.0000	1	1	0	1	1	0	0.4875
0	1	0	1	1	1	0.9750	1	1	0	1	1	1	0.4750
0	1	1	0	0	0	0.9500	1	1	1	0	0	0	0.4625
0	1	1	0	0	1	0.9250	1	1	1	0	0	1	0.4500
0	1	1	0	1	0	0.9000	1	1	1	0	1	0	0.4375
0	1	1	0	1	1	0.8750	1	1	1	0	1	1	0.4250
0	1	1	1	0	0	0.8500	1	1	1	1	0	0	0.4125
0	1	1	1	0	1	0.8250	1	1	1	1	0	1	0.4000
0	1	1	1	1	0	0.8000	1	1	1	1	1	0	0.3875
0	1	1	1	1	1	0.7750	1	1	1	1	1	1	0.3750

1. VID6 Not Applicable, need to be left unconnected.

6 Reference schematic

Figure 3. Reference schematic - Intel VR10.x, VR11 inductor sense

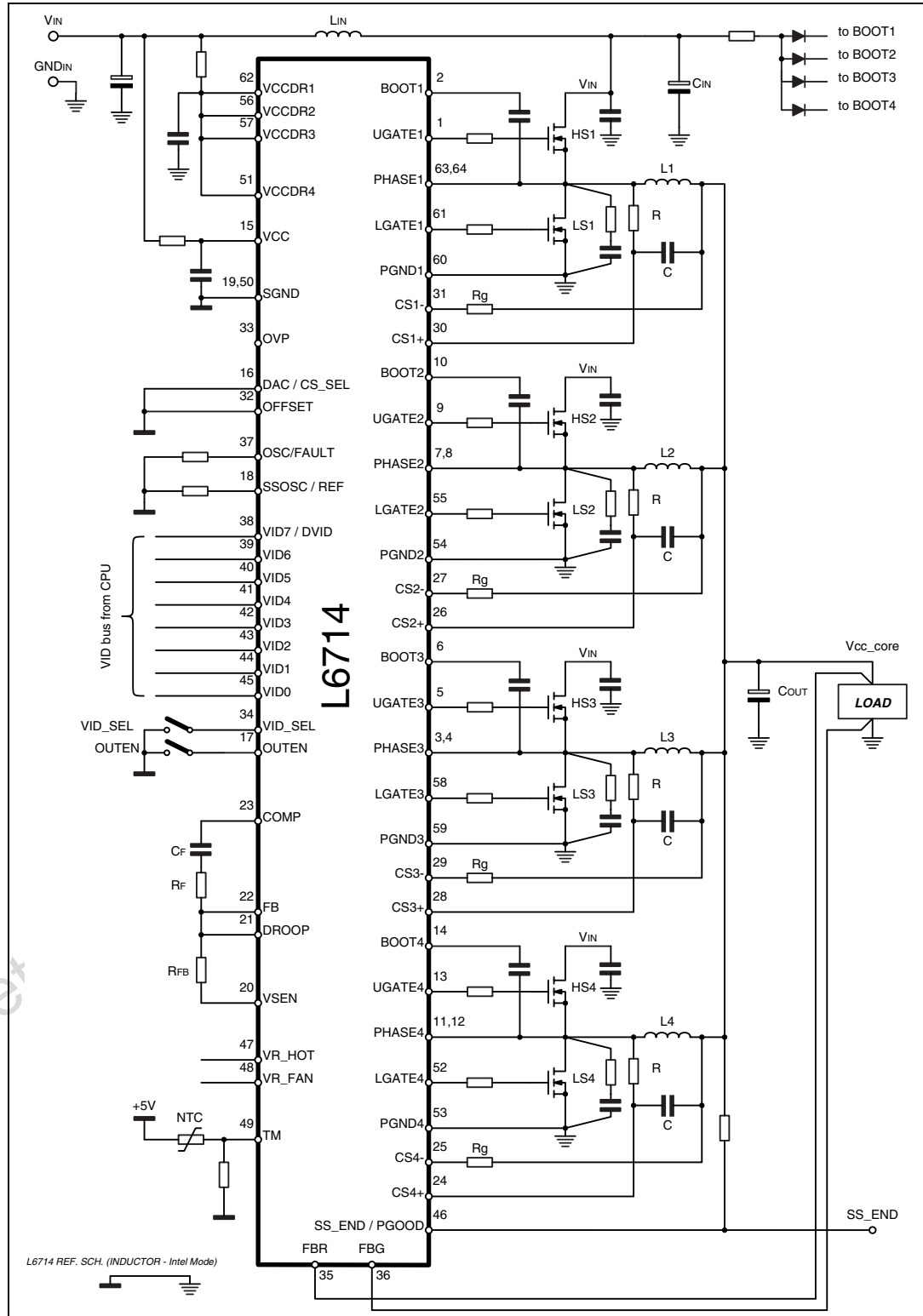

Obsolete

Figure 4. Reference schematic - Intel VR10.x, VR11 LS MOSFET sense

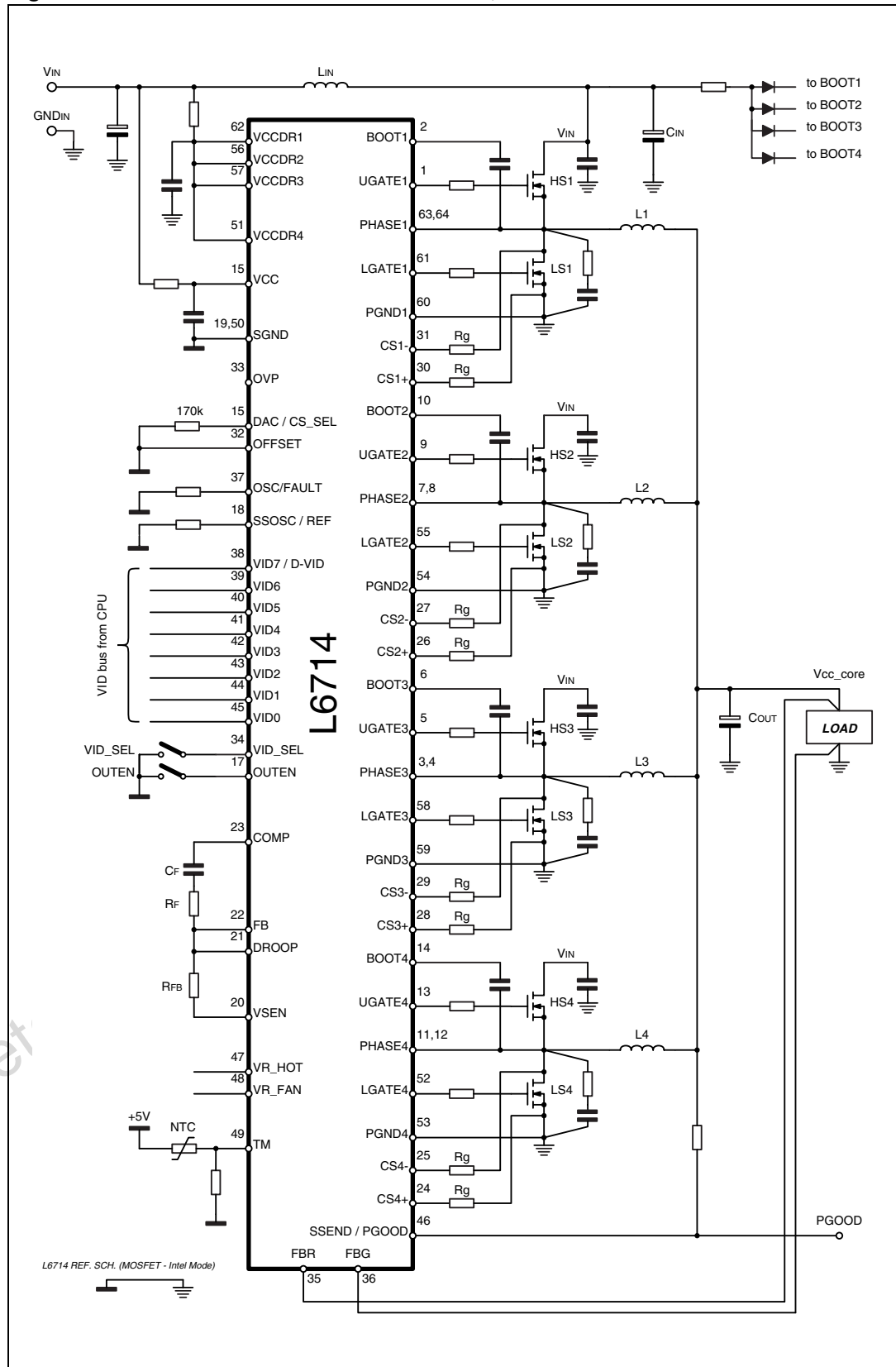

Obsolet

Figure 5. Reference schematic - AMD 6BIT inductor sense

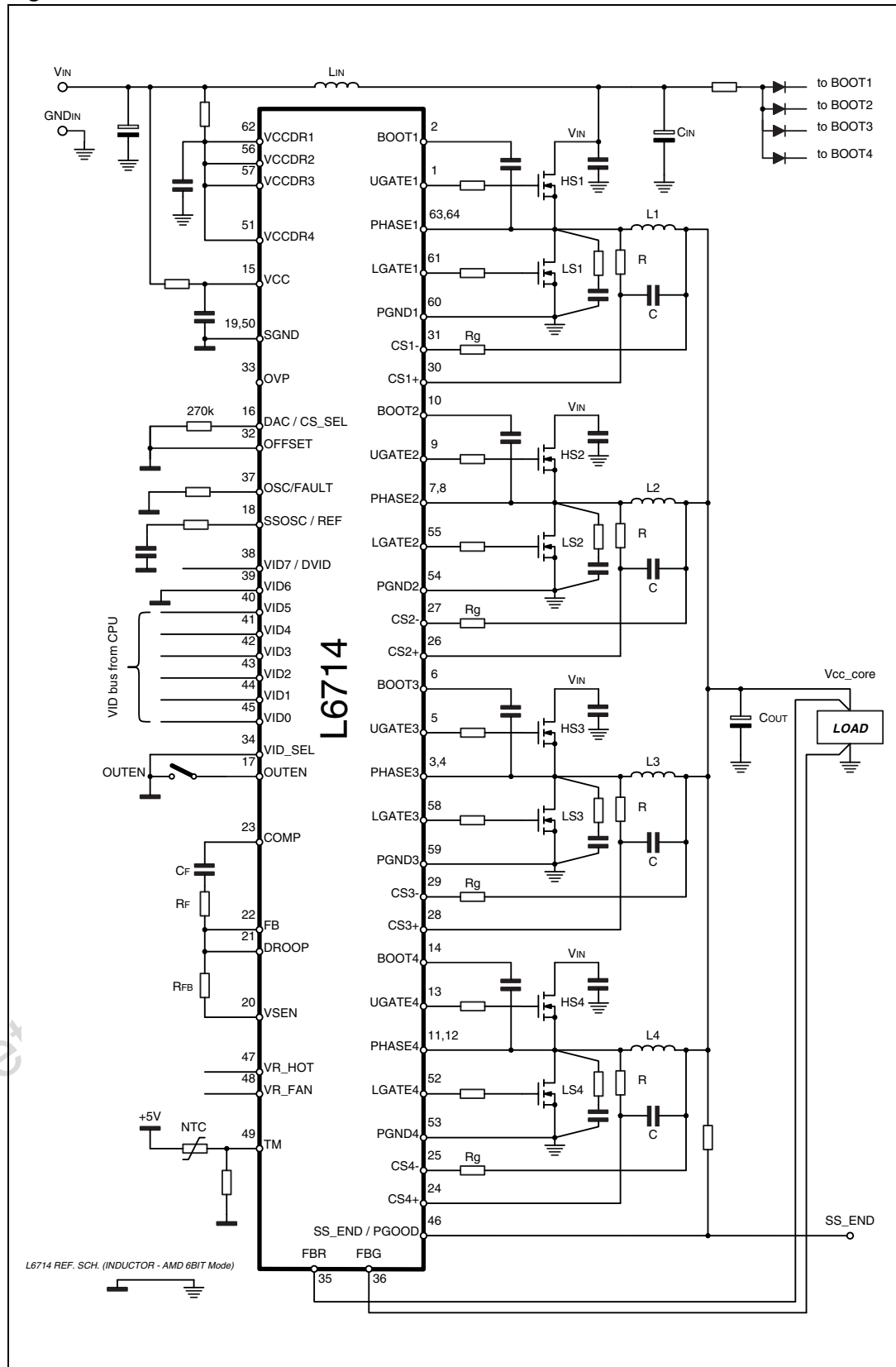
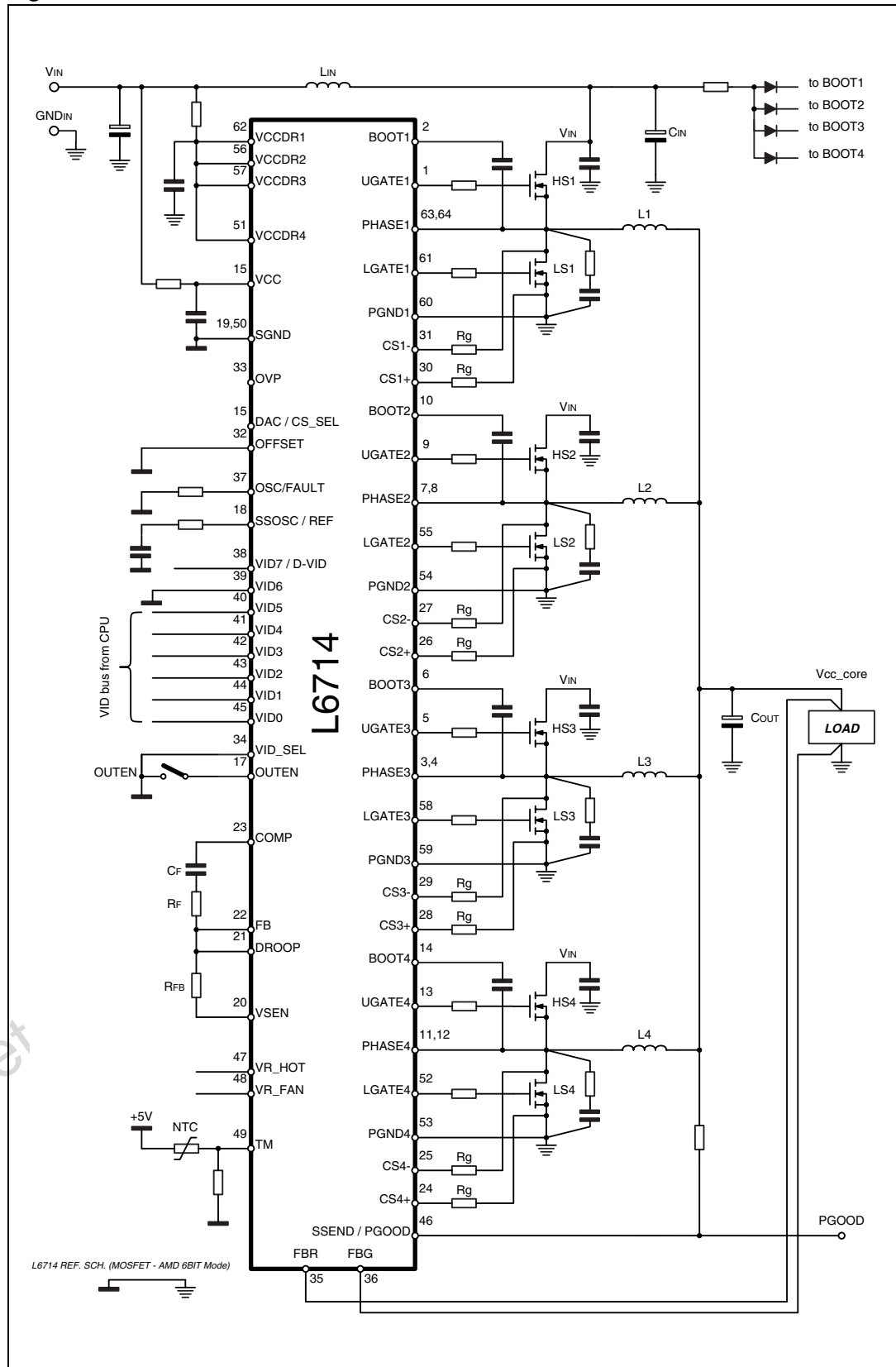

Figure 6. Reference schematic - AMD 6BIT LS MOSFET sense



7 Device description

L6714 is four-phase PWM controller with embedded high current drivers that provides complete control logic and protections for a high performance step-down DC-DC voltage regulator optimized for advanced microprocessor power supply. Multi phase buck is the simplest and most cost-effective topology employable to satisfy the increasing current demand of newer microprocessors and modern high current VRM modules. It allows distributing equally load and power between the phases using smaller, cheaper and most common external power MOSFET and inductors. Moreover, thanks to the equal phase shift between each phase, the input and output capacitor count results in being reduced. Phase interleaving causes in fact input RMS current and output ripple voltage reduction and show an effective output switching frequency increase: the 150kHz free-running frequency per phase, externally adjustable through a resistor, results multiplied on the output by the number of phases.

L6714 permits easy and flexible system design by allowing current reading across either inductor or low side MOSFET in fully differential mode simply selecting the desired way through apposite pin. In both cases, also a sense resistor in series to the related element can be considered to improve reading precision. The current information read corrects the PWM output in order to equalize the average current carried by each phase limiting the error at $\pm 3\%$ over static and dynamic conditions unless considering the sensing element spread.

The controller includes multiple DACs, selectable through an apposite pin, allowing compatibility with both Intel VR10, VR11 and AMD 6BIT processors specifications, also performing D-VID transitions accordingly.

Low-Side-Less start-up allows soft start over pre-biased output avoiding dangerous current return through the main inductors as well as negative spike at the load side.

L6714 provides programmable Over-Voltage protection to protect the load from dangerous over stress. It can be externally set to a fixed voltage through an apposite resistor, or it can be set internally, latching immediately by turning ON the lower driver and driving high the FAULT pin. Furthermore, preliminary OVP protection also allows the device to protect load from dangerous OVP when VCC is not above the UVLO threshold.

The Over-Current protection provided, with an OC threshold for each phase, causes the device to enter in constant current mode until the latched UVP.

L6714 provides system Thermal Monitoring: through an apposite pin the device senses the temperature of the hottest component in the application driving the Warning and the Alarm signal as a consequence.

A compact 10x10mm body TQFP64 package with exposed thermal pad allows dissipating the power to drive the external MOSFET through the system board.

8 Configuring the device

Multiple DACs and different current reading methodologies need to be configured before the system starts-up by programming the apposite pin DAC/CS_SEL.

The configuration of this pin identifies two main working areas (See Table 10) distinguishing between compliancy with Intel VR10,VR11 or AMD 6BIT specifications. According to the main specification considered, further customs can be done: main differences are regarding the DAC table, soft-start implementation, protection management and Dynamic VID Transitions. Of course, the Current Reading method can be still selected through DAC / CS_SEL pin.

See Table 11 and See Table 12 for further details about the device configuration.

8.1 DAC selection

L6714 embeds a selectable DAC (through DAC/CS_SEL, See Table 10) that allows to regulate the output voltage with a tolerance of $\pm 0.5\%$ ($\pm 0.6\%$ for AMD DAC) recovering from offsets and manufacturing variations. In case of selecting Intel Mode, the device automatically introduces a -19mV (both VRD10.x and VR11) offset to the regulated voltage in order to avoid any external offset circuitry to worsen the guaranteed accuracy and, as a consequence, the calculated system TOB.

Table 10. DAC / CS_SEL settings (See Note).

DAC / CS_SEL Resistance vs. SGND	DAC	Current sense method	OVP	UVP
0 (Short)	Intel	Inductor DCR	VID + 150mV (typ) or Programmable	-750mV (typ)
170k Ω		MOSFET R _{dsON}		
270k Ω	AMD	Inductor DCR	1.800V (typ) or Programmable	-750mV (typ)
OPEN		MOSFET R _{dsON}		

Note: Filter DAC/CS_SEL pin with 100pF(max) vs. SGND.

Output voltage is programmed through the VID pins: they are inputs of an internal DAC that is realized by means of a series of resistors providing a partition of the internal voltage reference. The VID code drives a multiplexer that selects a voltage on a precise point of the divider. The DAC output is delivered to an amplifier obtaining the voltage reference (i.e. the set-point of the error amplifier, V_{REF}).

Table 11. Intel mode configuration (See Note).

Pin	Function	Typical connection
DAC / CS_SEL	It allows selecting the Intel Mode and, furthermore, between Inductor or LS MOSFET current reading. Static info, no dynamic changes allowed.	SGND: Inductor Sense; 170kΩ to SGND: LS MOSFET Sense. Filter with 100pF(max).
SSOSC / REF	It allows programming the soft-start time T_{SS} . See "Soft start" Section for details.	Resistor R_{SSOSC} vs. SGND.
VID_SEL	It allows selecting between VR11 DAC or VR10.x + 6.25mV extended DAC. Static info, no dynamic changes allowed.	Open: VR11 (Table 6). Short to SGND: VR10.x (Table 7).
VID7 to VID0	They allow programming the Output Voltage according to Table 6 and Table 7. Dynamic transitions managed, See "Dynamic VID transitions" Section for details.	Open: Logic "1" (25μA pull-up) Short to SGND: "0"
SSEND / PGOOD	Soft Start end signal set free after soft-start has finished. It only indicates soft-start has finished.	Pull-up to anything lower than 5V.

Note: VID pull-ups / pull-downs, VID voltage thresholds and OUTEN thresholds changes according to the selected DAC: See Table 4 for details.

Table 12. AMD mode configuration (See Note).

Pin	Function	Typical connection
DAC / CS_SEL	It allows selecting the AMD mode and, furthermore, between Inductor or LS MOSFET current reading. Static info, no dynamic changes allowed.	270kΩ to SGND: Inductor Sense; OPEN: LS MOSFET Sense; Filter with 100pF(max).
SSOSC / REF	The reference used for the regulation is available on this pin.	Filter with 47Ω - 4.7nF vs. SGND.
VID_SEL	Not Applicable	Need to be shorted to SGND.
VID7 / DVID	Pulled high when performing a D-VID transition. The pin is kept high with a 32 clock cycles delay.	Not Applicable
VID6	Not Applicable	Needs to be shorted to SGND
VID5 to VID0	They allow programming the Output Voltage according to Table 9. Dynamic transitions managed, See "Dynamic VID transitions" Section for details.	Open: "0" (12.5μA pull-down) Pull-up to $V > 1.4V$: "1"
SSEND / PGOOD	Power Good signal set free after soft-start has finished whenever the output voltage is within limits.	Pull-up to anything lower than 5V.

Note: VID pull-ups / pull-downs, VID voltage thresholds and OUTEN thresholds changes according to the selected DAC: See Table 4 for details.

9 Power dissipation

L6714 embeds high current MOSFET drivers for both high side and low side MOSFET: it is then important to consider the power the device is going to dissipate in driving them in order to avoid overcoming the maximum junction operative temperature. In addition, since the device has an exposed pad to better dissipate the power, the thermal resistance between junction and ambient consequent to the layout is also important: thermal pad need to be soldered to the PCB ground plane through several VIAs in order to facilitate the heat dissipation.

Two main terms contribute to the device power dissipation: bias power and drivers' power. The first one (P_{DC}) depends on the static consumption of the device through the supply pins and is simply quantifiable as follows (assuming to supply HS and LS drivers with the same VCC of the device):

$$P_{DC} = V_{CC} \cdot (I_{CC} + N \cdot I_{CCDRx} + N \cdot I_{BOOTx})$$

where N is the number of phases.

Drivers' power is the power needed by the driver to continuously switch on and off the external MOSFET; it is a function of the switching frequency and total gate charge of the selected MOSFET. It can be quantified considering that the total power P_{SW} dissipated to switch the MOSFET (easy calculable) is dissipated by three main factors: external gate resistance (when present), intrinsic MOSFET resistance and intrinsic driver resistance. This last term is the important one to be determined to calculate the device power dissipation.

The total power dissipated to switch the MOSFET results:

$$P_{SW} = N \cdot F_{SW} \cdot (Q_{GHS} \cdot V_{BOOT} + Q_{GLS} \cdot V_{CCDRx})$$

External gate resistors help the device to dissipate the switching power since the same power P_{SW} will be shared between the internal driver impedance and the external resistor resulting in a general cooling of the device. When driving multiple MOSFET in parallel, it is suggested to use one gate resistor for each MOSFET.

Figure 7. L6714 dissipated power (Quiescent + switching).

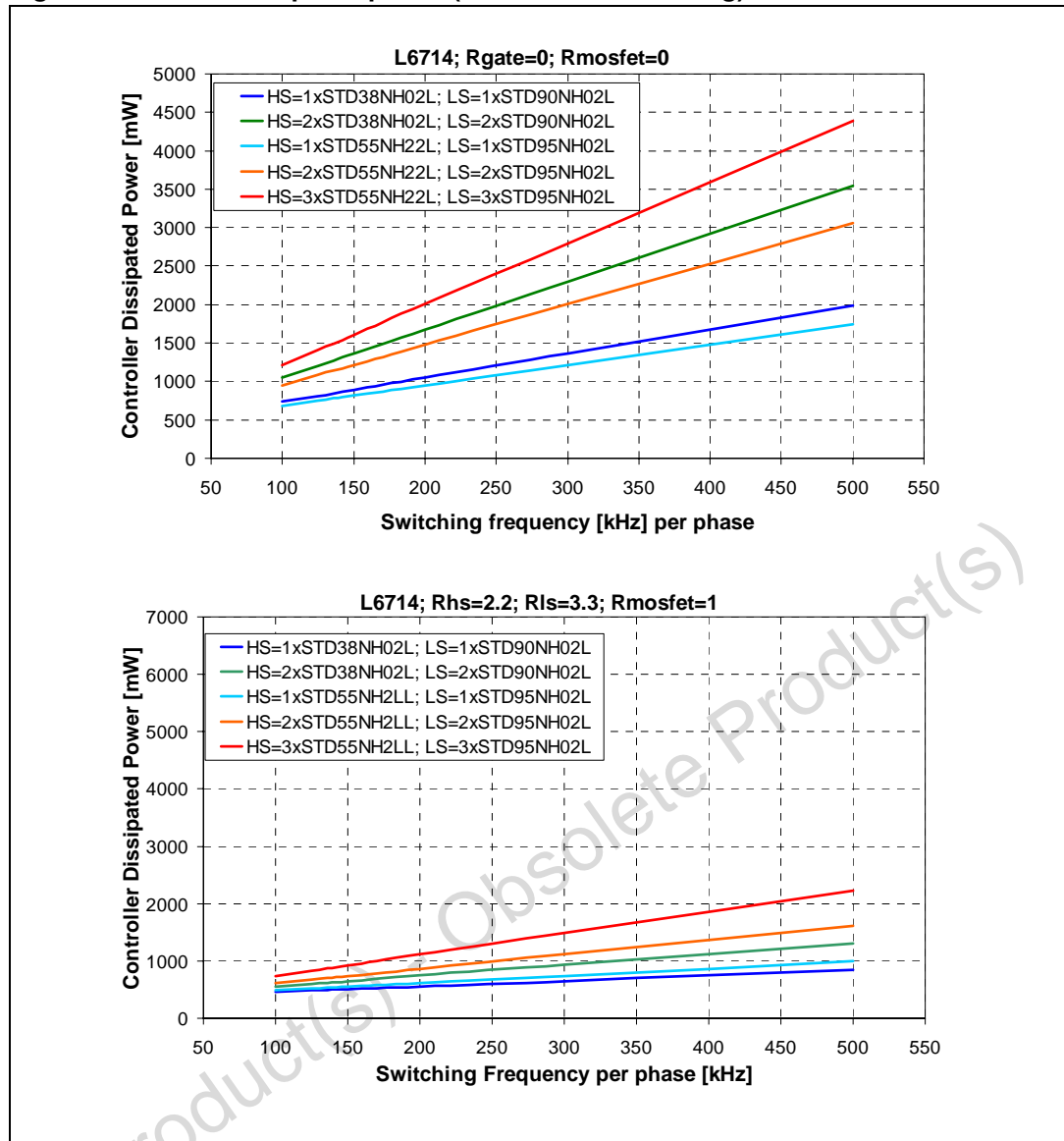

10 Current reading and current sharing loop

L6714 embeds a flexible, fully-differential current sense circuitry that is able to read across both low side or inductor parasitic resistance or across a sense resistor placed in series to that element. The fully-differential current reading rejects noise and allows placing sensing element in different locations without affecting the measurement's accuracy. The kind of sense element can be simply chosen through the DAC/CS_SEL pin according to [See Table 10](#).

Current sharing control loop reported in [Figure 8](#): it considers a current I_{INFOx} proportional to the current delivered by each phase and the average current $I_{AVG} = \sum I_{INFOx} / (N)$. The error between the read current I_{INFOx} and the reference I_{AVG} is then converted into a voltage that with a proper gain is used to adjust the duty cycle whose dominant value is set by the voltage error amplifier in order to equalize the current carried by each phase. Details about connections are shown in [Figure 9](#).

Figure 8. Current sharing loop.

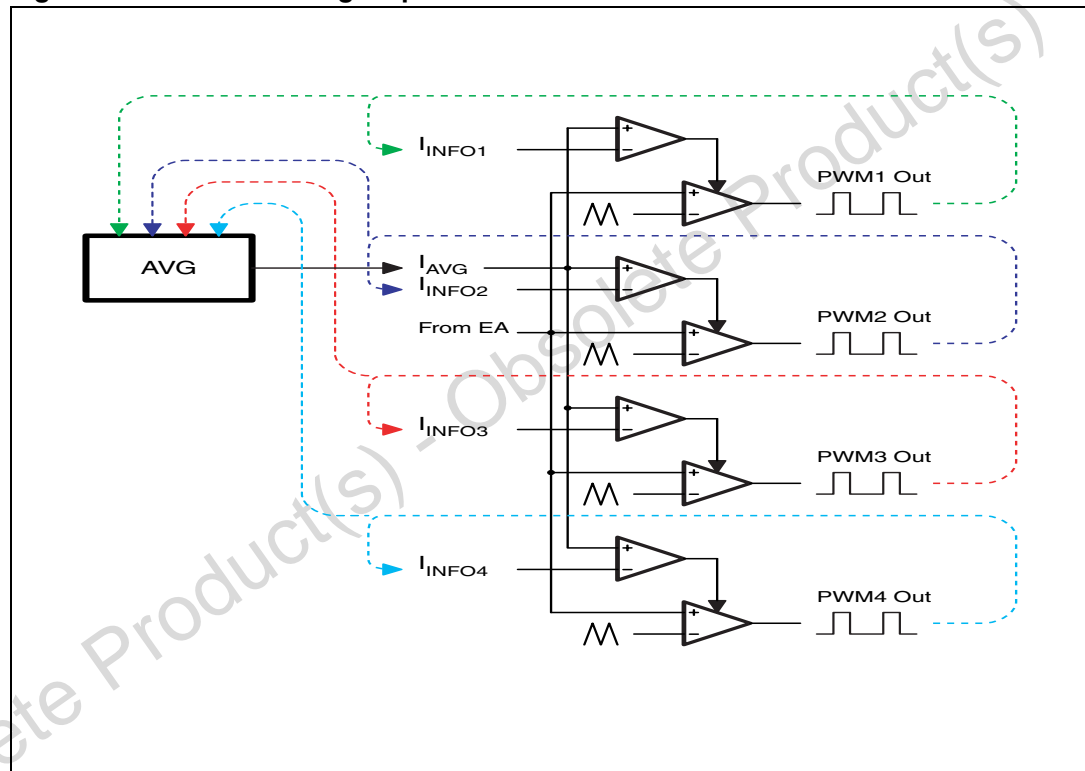

10.1 Low side current reading

When reading current across LS, the current flowing through each phase is read using the voltage drop across the low side MOSFET R_{dsON} or across a sense resistor in its series and it is internally converted into a current. The trans-conductance ratio is issued by the external resistor R_g placed outside the chip between CSx- and CSx+ pins toward the reading points.

The current sense circuit tracks the current information for a time T_{TRACK} centered in the middle of the LS conduction time and holds the tracked information during the rest of the period.

L6714 sources a constant $25\mu A$ bias current from the CSx+ pin: the current reading circuitry uses this pin as a reference and the reaction keeps the CSx- pin to this voltage during the reading time (an internal clamp keeps CSx+ and CSx- at the same voltage sinking from the CSx- pin the necessary current during the hold time; this is needed to avoid absolute maximum rating overcome on CSx- pin). The current that flows from the CSx- pin is then given by (See Figure 9):

$$I_{CSx-} = 25\mu A + \frac{R_{dsON}}{R_g} \cdot I_{PHASEx} = 25\mu A + I_{INFOx}$$

where R_{dsON} is the ON resistance of the low side MOSFET and R_g is the trans-conductance resistor used between CSx- and CSx+ pins toward the reading points; I_{PHASEx} is the current carried by the relative phase and I_{INFOx} is the current information signal reproduced internally.

$25\mu A$ offset allows negative current reading, enabling the device to check for dangerous returning current between the phases assuring the complete current equalization.

10.2 Inductor current reading

When reading current across the inductor DCR, the current flowing through each phase is read using the voltage drop across the output inductor or across a sense resistor in its series and internally converted into a current. The trans-conductance ratio is issued by the external resistor R_g placed outside the chip between CSx- pin toward the reading points.

The current sense circuit always tracks the current information, no bias current is sourced from the CSx+ pin: this pin is used as a reference keeping the CSx- pin to this voltage. To correctly reproduce the inductor current an R-C filtering network must be introduced in parallel to the sensing element.

The current that flows from the CSx- pin is then given by the following equation (See Figure 9):

$$I_{CSx-} = \frac{R_L}{R_g} \cdot \frac{1 + s \cdot L / R_L}{1 + s \cdot R \cdot C} \cdot I_{PHASEx}$$

Where I_{PHASEx} is the current carried by the relative phase.

Figure 9. Current reading connections.

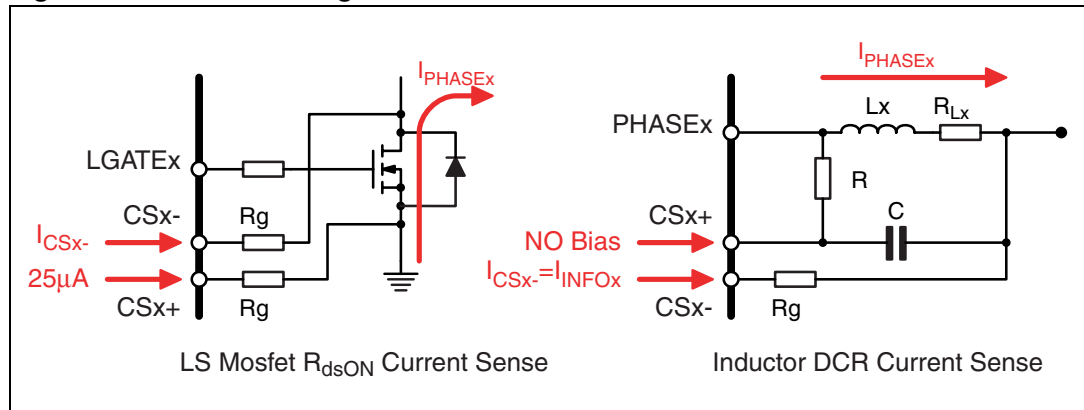

Considering now to match the time constant between the inductor and the R-C filter applied (Time constant mismatches cause the introduction of poles into the current reading network causing instability. In addition, it is also important for the load transient response and to let the system show resistive equivalent output impedance), it results:

$$\frac{L}{R_L} = R \cdot C \Rightarrow I_{CSx-} = \frac{R_L}{R_g} \cdot I_{PHASEx} = I_{INFOx} \Rightarrow I_{INFOx} = \frac{R_L}{R_g} \cdot I_{PHASEx}$$

Where I_{INFOx} is the current information reproduced internally.

11 Remote voltage sense

The device embeds a Remote Sense Buffer to sense remotely the regulated voltage without any additional external components. In this way, the output voltage programmed is regulated between the remote buffer inputs compensating motherboard or connector losses. It senses the output voltage remotely through the pins FBR and FBG (FBR is for the regulated voltage sense while FBG is for the ground sense) and reports this voltage internally at VSEN pin with unity gain eliminating the errors. Keeping the FBR and FBG traces parallel and guarded by a power plane results in common mode coupling for any picked-up noise.

If remote sense is not required, it is enough connecting the resistor R_{FB} directly to the regulated voltage: VSEN becomes not connected and still senses the output voltage through the remote buffer. In this case the FBG and FBR pins must be connected anyway to the regulated voltage (See Figure 10).

Warning: The remote buffer is included in the trimming chain in order to achieve $\pm 0.5\%$ accuracy (0.6% for the AMD DAC) on the output voltage when the RB is used: eliminating it from the control loop causes the regulation error to be increased by the RB offset worsening the device performances.

Figure 10. Remote buffer connections

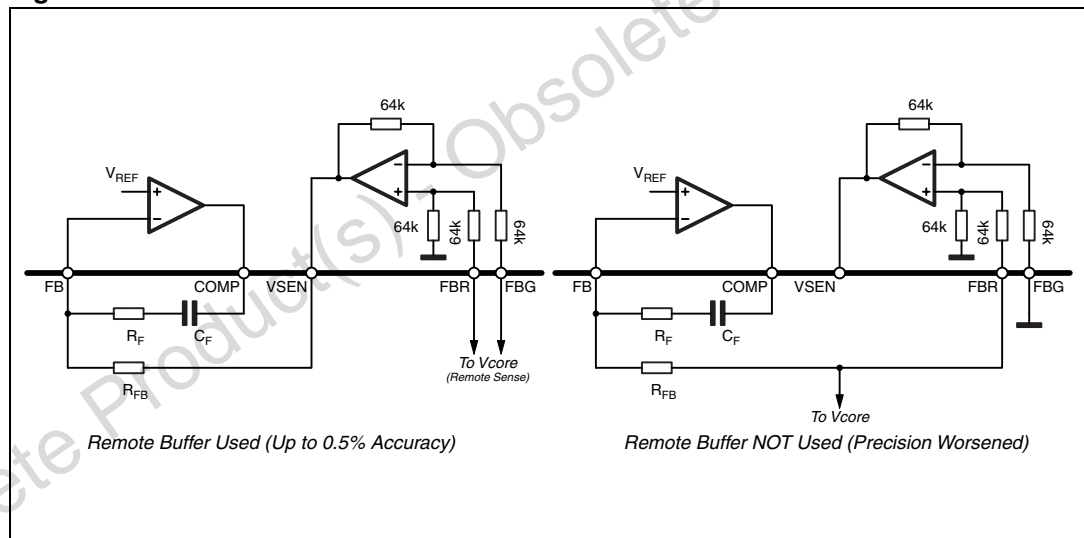

12 Voltage positioning

Output voltage positioning is performed by selecting the reference DAC and by programming the Droop Function and Offset to the reference (See Figure 11). The currents sourced from DROOP and FB pins cause the output voltage to vary according to the external R_{FB} resistor.

In addition, the embedded Remote Buffer allows to precisely programming the output voltage offsets and variations by recovering the voltage drops across distribution lines.

The output voltage is then driven by the following relationship:

$$V_{OUT} = V_{REF} - R_{FB} \cdot (I_{DROOP} - I_{OFFSET})$$

where

$$V_{REF} = \begin{cases} VID - 19mV & VR10 - VR11 \\ VID & AMD 6BIT \end{cases}$$

DROOP function can be disabled as well as the OFFSET: connecting DROOP pin and FB pin together implements the load regulation dependence while, if this effect is not desired, by shorting DROOP pin to SGND it is possible for the device to operate as a classic Voltage Mode Buck converter. The DROOP pin can also be connected to SGND through a resistor obtaining a voltage proportional to the delivered current usable for monitoring purposes. OFFSET can be disabled by shorting the relative pin to SGND.

12.1 Droop function (Optional)

This method "recovers" part of the drop due to the output capacitor ESR in the load transient, introducing a dependence of the output voltage on the load current: a static error proportional to the output current causes the output voltage to vary according to the sensed current.

As shown in Figure 11, the ESR drop is present in any case, but using the droop function the total deviation of the output voltage is minimized. Moreover, more and more high-performance CPUs require precise load-line regulation to perform in the proper way. DROOP function is not then required only to optimize the output filter, but also becomes a requirement of the load.

Connecting DROOP pin and FB pin together, the device forces a current I_{DROOP} proportional to the read current, into the feedback resistor R_{FB} implementing the load regulation dependence. Since I_{DROOP} depends on the current information about the three phases, the output characteristic vs. load current is then given by:

$$V_{OUT} = V_{REF} - R_{FB} \cdot I_{DROOP} = V_{REF} - R_{FB} \cdot \frac{R_{SENSE}}{R_g} \cdot I_{OUT} = V_{REF} - R_{DROOP} \cdot I_{OUT}$$

Where R_{SENSE} is the chosen sensing element resistance (Inductor DCR or LS R_{dsON}) and I_{OUT} is the output current of the system.

The whole power supply can be then represented by a "real" voltage generator with an equivalent output resistance R_{DROOP} and a voltage value of $V_{REF} - R_{FB}$ resistor can be also designed according to the R_{DROOP} specifications as follow:

$$R_{FB} = R_{DROOP} \cdot \frac{R_g}{R_{SENSE}}$$

Droop function is optional, in case it is not desired, the DROOP pin can be disconnected from the FB and an information about the total delivered current becomes available for debugging, and/or current monitoring. When not used, the pin can be shorted to SGND.

Figure 11. Voltage positioning (left) and droop function (right)

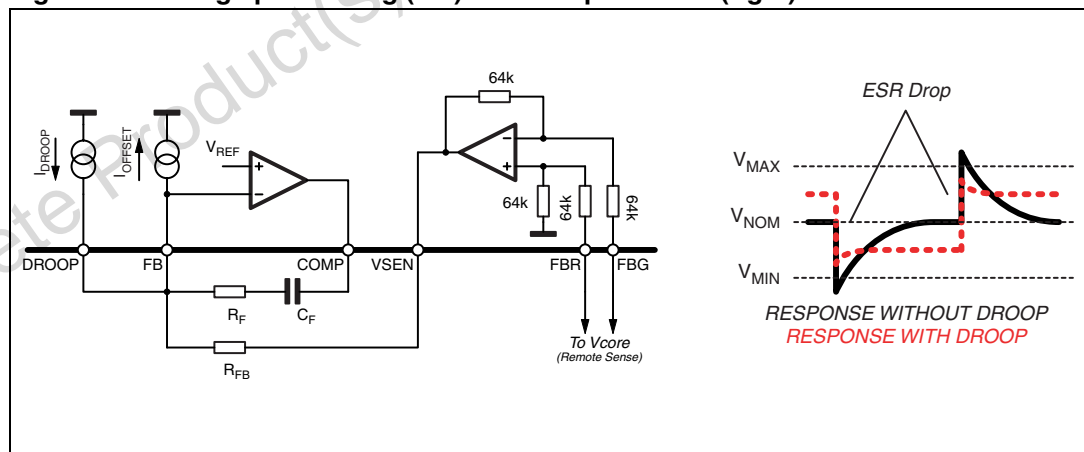

12.2 Offset (Optional)

The OFFSET pin allows programming a positive offset (V_{OS}) for the output voltage by connecting a resistor R_{OFFSET} vs. SGND; this offset has to be considered in addition to the one already introduced during the production stage for the Intel VR10, VR11 Mode.

The OFFSET pin is internally fixed at 1.240V (See Table 4) a current is programmed by connecting the resistor R_{OFFSET} between the pin and SGND: this current is mirrored and then properly sunk from the FB pin as shown in Figure 12. Output voltage is then programmed as follow:

$$V_{OUT} = V_{REF} - R_{FB} \cdot (I_{DROOP} - I_{OFFSET})$$

Offset resistor can be designed by considering the following relationship (R_{FB} is fixed by the Droop effect):

$$R_{OFFSET} = \frac{1.240V}{V_{OS}} \cdot R_{FB}$$

Offset automatically given by the DAC selection differs from the offset implemented through the OFFSET pin: the built-in feature is trimmed in production and assures $\pm 0.5\%$ error ($\pm 0.6\%$ for the AMD DAC) over load and line variations.

Figure 12. Voltage positioning with offset

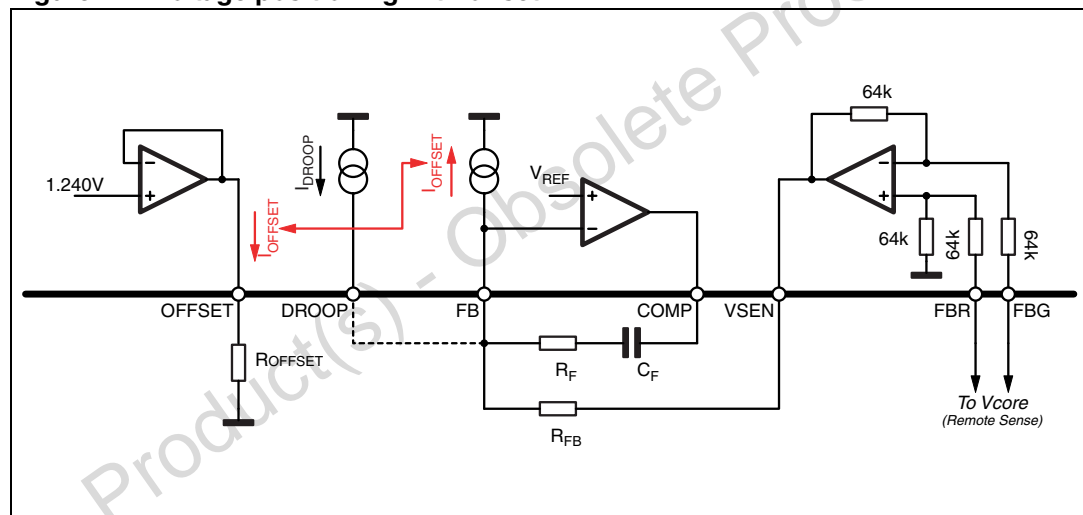

13 Dynamic VID transitions

The device is able to manage Dynamic VID Code changes that allow Output Voltage modification during normal device operation. OVP and UVP signals (and PGOOD in case of AMD Mode) are masked during every VID transition and they are re-activated after the transition finishes with a 32 clock cycles delay to prevent from false triggering due to the transition.

When changing dynamically the regulated voltage (D-VID), the system needs to charge or discharge the output capacitor accordingly. This means that an extra-current I_{D-VID} needs to be delivered, especially when increasing the output regulated voltage and it must be considered when setting the over current threshold. This current can be estimated using the following relationships:

$$I_{D-VID} = C_{OUT} \cdot \frac{dV_{OUT}}{dT_{VID}}$$

where dV_{OUT} is the selected DAC LSB (6.25mV for VR11 and VR10 Extended DAC or 25mV for AMD DAC) and T_{VID} is the time interval between each LSB transition (externally driven). Overcoming the OC threshold during the dynamic VID causes the device to enter the constant current limitation slowing down the output voltage dV/dt also causing the failure in the D-VID test.

L6714 checks for VID code modifications (See Figure 13) on the rising edge of an internal additional DVID-clock and waits for a confirmation on the following falling edge. Once the new code is stable, on the next rising edge, the reference starts stepping up or down in LSB increments every VID-clock cycle until the new VID code is reached. During the transition, VID code changes are ignored; the device re-starts monitoring VID after the transition has finished on the next rising edge available. VID-clock frequency (F_{DVID}) depends on the operative mode selected: for Intel Mode it is in the range of 1MHz to assure compatibility with the specifications while, for AMD Mode, this frequency is lowered to about 250kHz.

When L6714 performs a D-VID transition in AMD Mode, DVID pin is pulled high as long as the device is performing the transition (also including the additional 32clocks delay)

Warning: If the new VID code is more than 1 LSB different from the previous, the device will execute the transition stepping the reference with the DVID-clock frequency F_{DVID} until the new code has reached: for this reason it is recommended to carefully control the VID change rate in order to carefully control the slope of the output voltage variation especially in Intel Mode.

Figure 13. Dynamic VID transitions

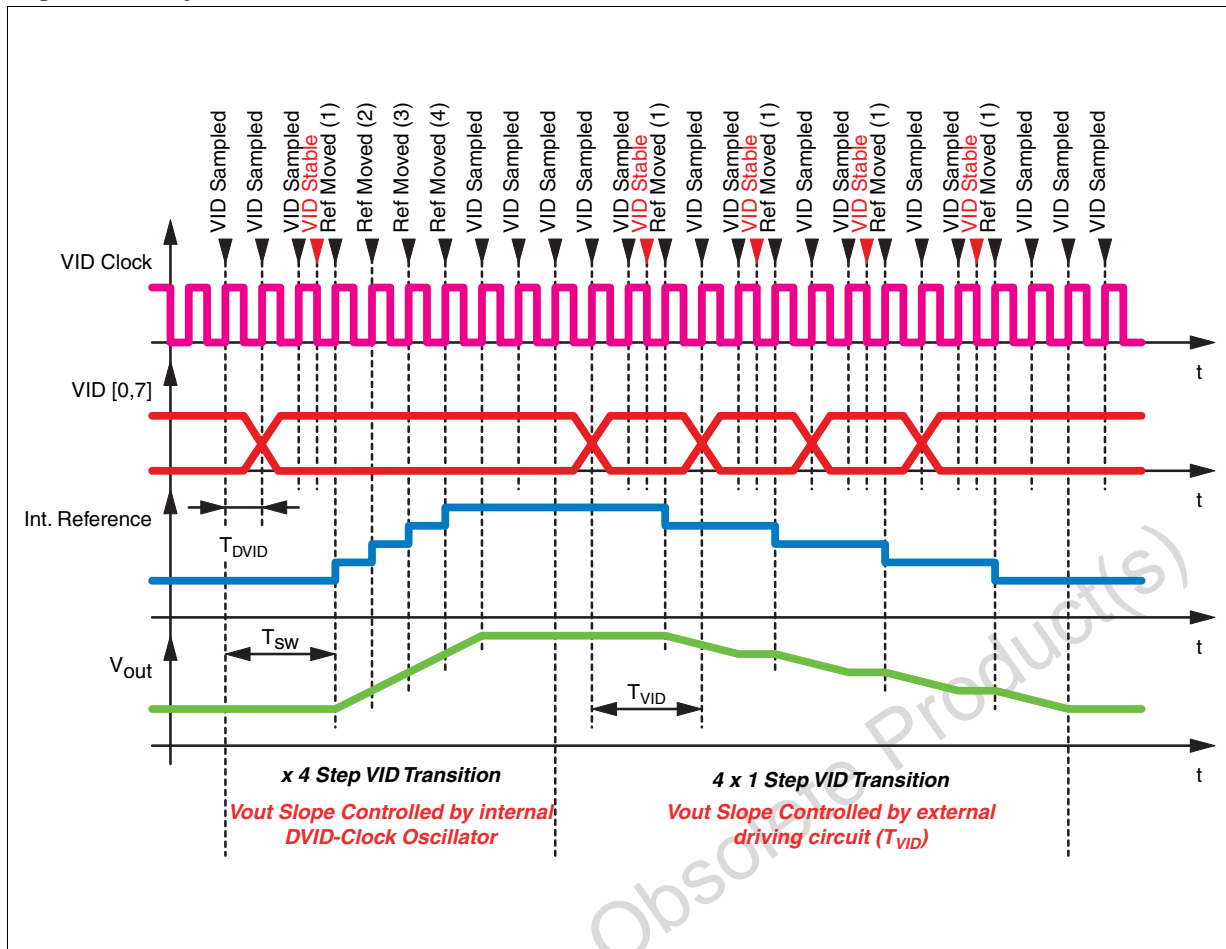

14 Enable and disable

L6714 has three different supplies: VCC pin to supply the internal control logic, VCCDRx to supply the low side drivers and BOOTx to supply the high side drivers.

If the voltage at pins VCC and VCCDRx are not above the turn on thresholds specified in the [Electrical characteristics](#), the device is shut down: all drivers keep the MOSFET off to show high impedance to the load.

Once the device is correctly supplied, proper operation is assured and the device can be driven by the OUTEN pin to control the power sequencing.

Setting the pin free, the device implements a soft start up to the programmed voltage. Shorting the pin to SGND, it resets the device (SS_END/PGOOD is shorted to SGND in this condition) from any latched condition and also disables the device keeping all the MOSFET turned off to show high impedance to the load.

Obsolete Product(s) - Obsolete Product(s)

15 Soft start

L6714 implements a soft-start to smoothly charge the output filter avoiding high in-rush currents to be required to the input power supply. The device increases the reference from zero up to the programmed value in different ways according to the selected Operative Mode and the output voltage increases accordingly with closed loop regulation.

The device implements Soft-Start only when all the power supplies are above their own turn-on thresholds and the OUTEN pin is set free.

At the end of the digital Soft-Start, SS_END/PGOOD signal is set free. Protections are active during this phase; Under Voltage is enabled when the reference voltage reaches 0.6V while Over Voltage is always enabled with a threshold dependent on the selected Operative Mode or with the fixed threshold programmed by R_{OVP} (See "Over voltage and programmable OVP" Section).

Figure 14. Soft start

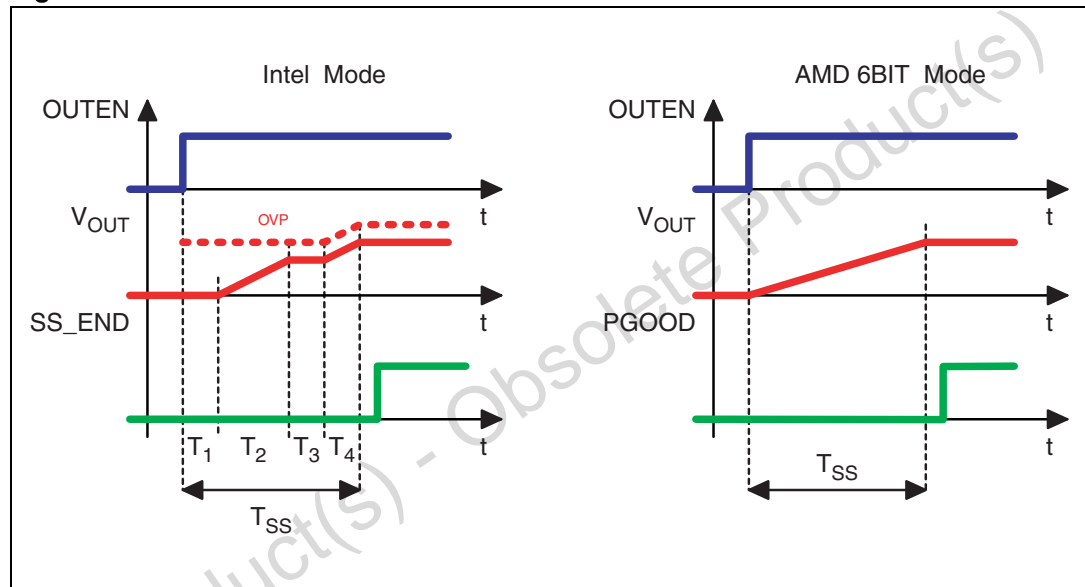

15.1 Intel mode

Once L6714 receives all the correct supplies and enables, and Intel Mode has been selected, it initiates the Soft-Start phase with a $T_1 = 1\text{ms}_{(\text{min})}$ delay. After that, the reference ramps up to $V_{\text{BOOT}} = 1.081\text{V}$ ($1.100\text{V} - 19\text{mV}$) in T_2 according to the SSOSC settings and waits for $T_3 = 75\mu\text{sec}_{(\text{typ})}$ during which the device reads the VID lines. Output voltage will then ramps up to the programmed value in T_4 with the same slope as before (See Figure 14).

SSOSC defines the frequency of an internal additional Soft-Start-oscillator used to step the reference from zero up to the programmed value; this oscillator is independent from the main oscillator whose frequency is programmed through the OSC pin. SSOSC sets then the Output Voltage dV/dt during Soft-Start according to the resistor R_{SSOSC} connected vs. SGND. In particular, it allows to precisely programming the start-up time up to V_{BOOT} (T_2) since it is a fixed voltage independent by the programmed VID. Total Soft-Start time dependence on the programmed VID results (See Figure 15):

$$R_{\text{SSOSC}}[\text{k}\Omega] = T_2[\mu\text{s}] \cdot 4.9783 \cdot 10^{-2}$$

$$T_{\text{SS}}[\mu\text{s}] = 1075[\mu\text{s}] + \begin{cases} \frac{R_{\text{SSOSC}}[\text{k}\Omega]}{5.3816 \cdot 10^{-2}} \cdot V_{\text{SS}} & \text{if}(V_{\text{SS}} > V_{\text{BOOT}}) \\ \frac{R_{\text{SSOSC}}[\text{k}\Omega]}{5.3816 \cdot 10^{-2}} \cdot [V_{\text{BOOT}} + (V_{\text{BOOT}} - V_{\text{SS}})] & \text{if}(V_{\text{SS}} < V_{\text{BOOT}}) \end{cases}$$

where T_{SS} is the time spent to reach the programmed voltage V_{SS} and R_{SSOSC} the resistor connected between SSOSC and SGND in $\text{k}\Omega$.

Protections are active during Soft-Start, UVP is enabled after the reference reaches 0.6V while OVP is always active with a fixed 1.24V threshold before V_{BOOT} and with the threshold coming from the VID (or the programmed V_{OVP}) after V_{BOOT} (See red-dashed line in Figure 14).

Note: *If during T_3 the programmed VID selects an output voltage lower than V_{BOOT} , the output voltage will ramp to the programmed voltage starting from V_{BOOT} .*

Figure 15. Soft-start time for Intel mode.

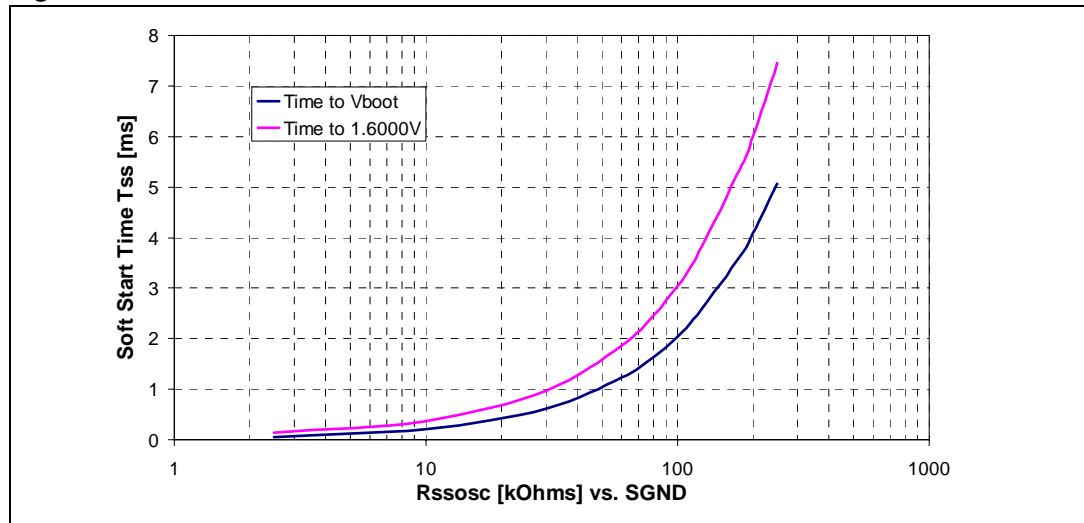

15.2 AMD mode

Once L6714 receives all the correct supplies and enables, and AMD Mode has been selected, it initiates the Soft-Start by stepping the reference from zero up to the programmed VID code (See Figure 14); the clock now used to step the reference is the same as the main oscillator programmed by the OSC pin, SSOSC pin is not applicable in this case. The Soft-Start time results then (See Figure 16):

$$\frac{dV_{OUT}}{dT} = 3.125 \cdot F_{SW}[kHz] \Rightarrow T_{SS} = \frac{V_{SS}}{3.125 \cdot F_{SW}[kHz]}$$

where T_{SS} is the time spent to reach V_{SS} and F_{SW} is the main switching frequency programmed by OSC pin. Protections are active during Soft-Start, UVP is enabled after the reference reaches 0.6V while OVP is always active with the fixed 1.800V threshold (or the programmed V_{OVP}).

Figure 16. Soft-start time for AMD mode

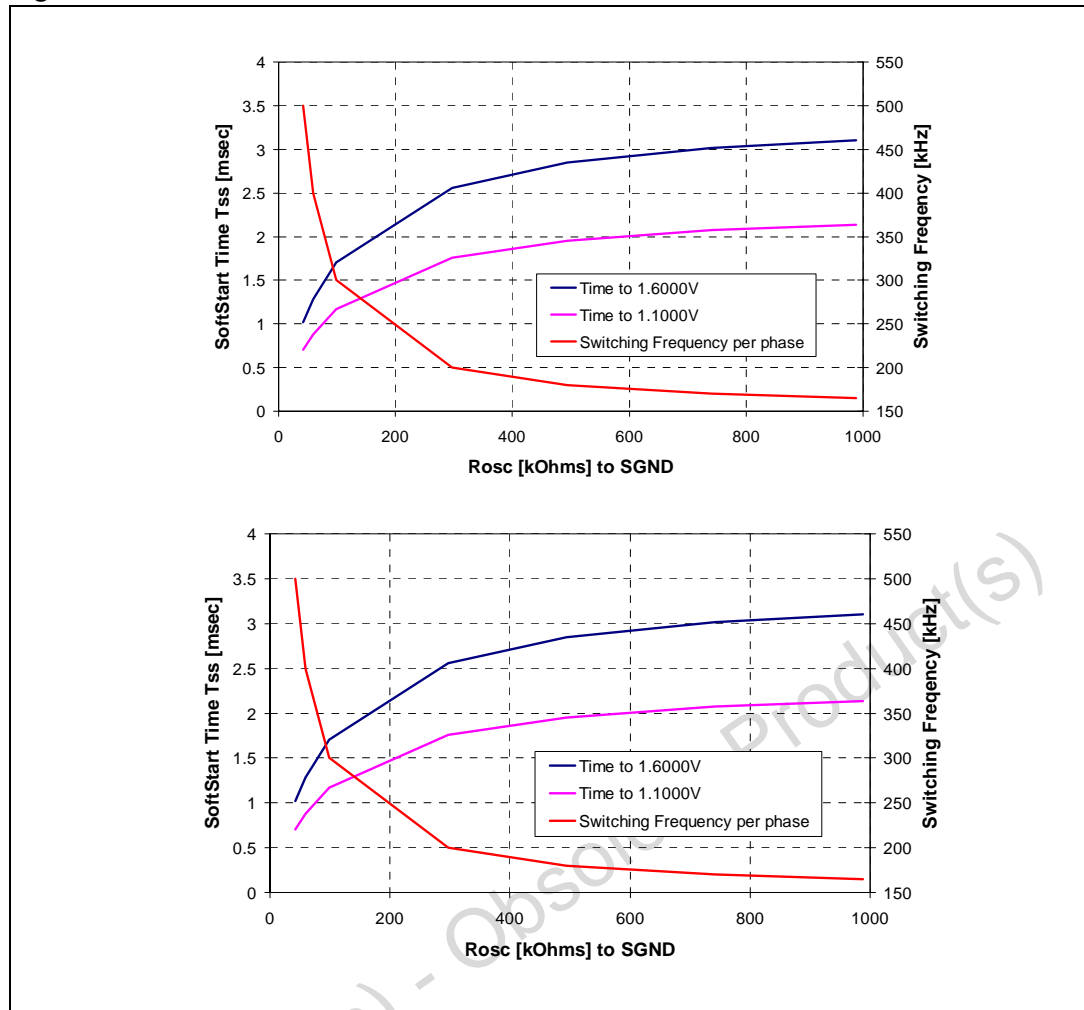

Obsolete Product(s) - Obsolete Product(s)

15.3 Low-Side-Less startup

In order to avoid any kind of negative undershoot on the load side during start-up, L6714 performs a special sequence in enabling LS driver to switch: during the soft-start phase, the LS driver results disabled (LS=OFF) until the HS starts to switch. This avoid the dangerous negative spike on the output voltage that can happen if starting over a pre-biased output (See Figure 17).

This particular feature of the device masks the LS turn-on only from the control loop point of view: protections are still allowed to turn-ON the LS MOSFET in case of over voltage if needed.

Figure 17. Low-Side-Less start-up comparison

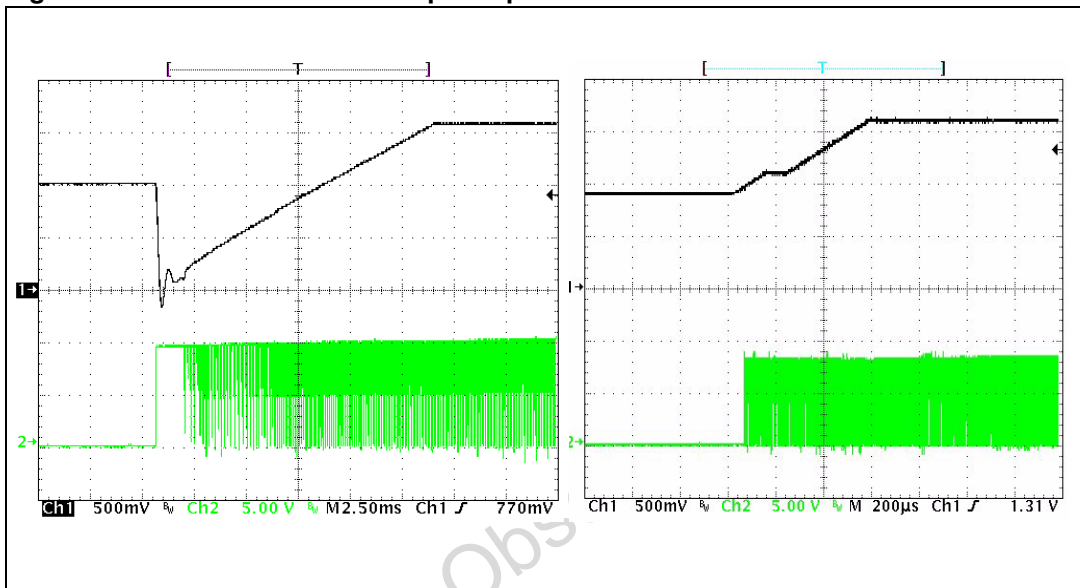

Obsolete Product(s) - Obs

16 Output voltage monitor and protections

L6714 monitors through pin VSEN the regulated voltage in order to manage the OVP, UVP and PGOOD (when applicable) conditions. The device shows different thresholds when programming different operation mode (Intel or AMD, See Table 10) but the behavior in response to a protection event is still the same as described below.

Protections are active also during soft-start (See “Soft start” Section) while are masked during D-VID transitions with an additional 32 clock cycle delay after the transition has finished to avoid false triggering.

16.1 Under voltage

If the output voltage monitored by VSEN drops more than -750mV below the programmed reference for more than one clock period, L6714 turns off all MOSFET and latches the condition: to recover it is required to cycle Vcc or the OUTEN pin. This is independent of the selected operative mode.

16.2 Preliminary over voltage

To provide a protection while VCC is below the $UVLO_{VCC}$ threshold is fundamental to avoid damage to the CPU in case of failed HS MOSFET. In fact, since the device is supplied from the 12V bus, it is basically “blind” for any voltage below the turn-on threshold ($UVLO_{VCC}$). In order to give full protection to the load, a preliminary-OVP protection is provided while VCC is within $UVLO_{VCC}$ and $UVLO_{OVP}$

This protection turns-on the low side MOSFET as long as the FBR pin voltage is greater than 1.800V with a 350mV hysteresis. When set, the protection drives the LS MOSFET with a gate-to-source voltage depending on the voltage applied to VCCDRx and independently by the turn-ON threshold across these pins ($UVLO_{VCCDR}$). This protection depends also on the OUTEN pin status as detailed in Figure 18.

A simple way to provide protection to the output in all conditions when the device is OFF (then avoiding the unprotected red region in Figure 18-Left) consists in supplying the controller through the $5V_{SB}$ bus as shown in Figure 18-Right: $5V_{SB}$ is always present before +12V and, in case of HS short, the LS MOSFET is driven with 5V assuring a reliable protection of the load. Preliminary OVP is always active before $UVLO_{VCC}$ for both Intel and AMD Modes.

Figure 18. Output voltage protections and typical principle connections

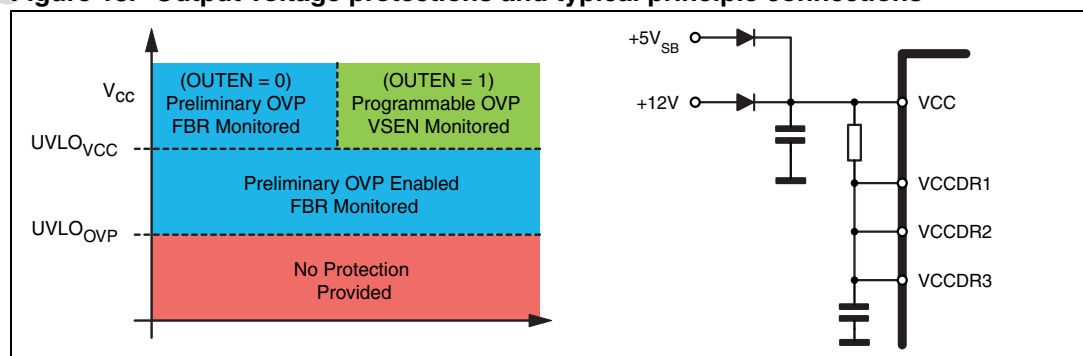

16.3 Over voltage and programmable OVP

Once VCC crosses the turn-ON threshold and the device is enabled (OUTEN = 1), L6714 provides an Over Voltage Protection: when the voltage sensed by VSEN overcomes the OVP threshold, the controller permanently switches on all the low-side MOSFET and switches off all the high-side MOSFET in order to protect the load. The OSC/ FAULT pin is driven high (5V) and power supply or OUTEN pin cycling is required to restart operations. The OVP Threshold varies according to the operative mode selected (See Table 10).

The OVP threshold can be also programmed through the OVP pin: leaving the pin floating, it is internally pulled-up and the OVP threshold is set according to Table 10. Connecting the OVP pin to SGND through a resistor R_{OVP} the OVP threshold becomes the voltage present at the pin. Since the OVP pin sources a constant $I_{OVP} = 12.5\mu A$ current (See Table 10), the programmed voltage becomes:

$$OVP_{TH} = R_{OVP} \cdot 12.5\mu A \quad \Rightarrow \quad R_{OVP} = \frac{OVP_{TH}}{12.5\mu A}$$

Filter OVP pin with 100pF(max) vs. SGND.

16.4 PGOOD (Only for AMD mode)

It is an open-drain signal set free after the soft-start sequence has finished. It is pulled low when the output voltage drops below -300mV of the programmed voltage.

17 Maximum Duty-cycle limitation

The device limits the maximum duty cycle and this value is not fixed but it depends on the delivered current given by the following relationship:

$$D_{(max)} = 0.80 - (I_{DROOP} \times 2.857k) = 0.80 - \left(\frac{R_{SENSE}}{R_g} \times I_{OUT} \times 2.857k \right)$$

From the previous relationships the maximum duty cycle results:

$$D_{(max)} = \begin{cases} 80\% & I_{DROOP} = 0\mu A \\ 40\% & I_{DROOP} = 140\mu A \end{cases}$$

If the desired output characteristic crosses the limited- D_{MAX} maximum output voltage, the output resulting voltage will start to drop after the cross-point. In this case the output voltage starts to decrease following the resulting characteristic (dotted in Figure 19) until UVP is detected or anyway until $I_{DROOP}=140\mu A$.

Figure 19. Maximum Duty-Cycle (left) and limited D_{MAX} output voltage (right)

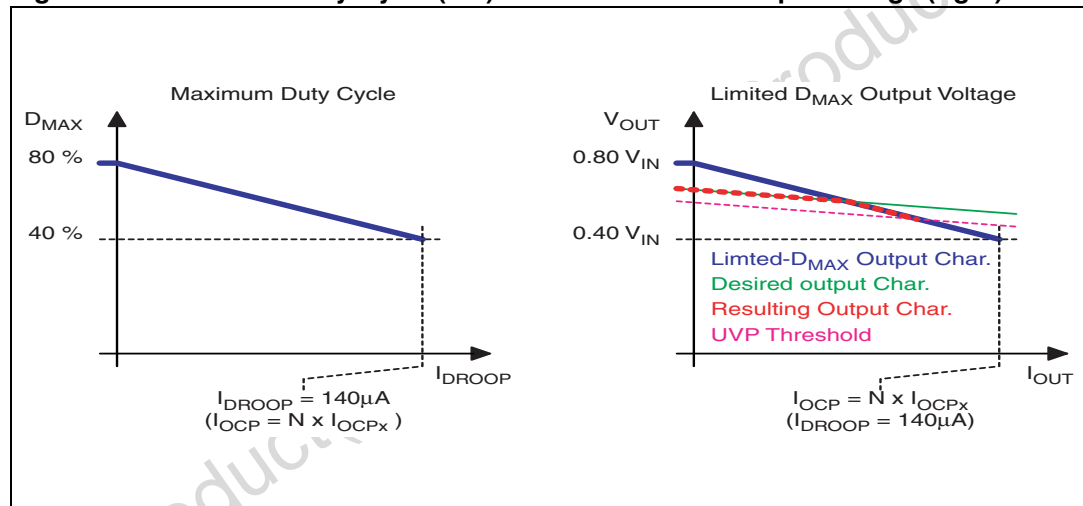

18 Over current protection

Depending on the current reading method selected, the device limits the peak or the bottom of the inductor current entering in constant current until setting UVP as below explained.

The Over Current threshold has to be programmed, by designing the Rg resistors, to a safe value, in order to be sure that the device doesn't enter OCP during normal operation of the device. This value must take into consideration also the extra current needed during the Dynamic VID Transition I_{D-VID} and, since the device reads across MOSFET R_{dsON} or inductor DCR, the process spread and temperature variations of these sensing elements.

Moreover, since also the internal threshold spreads, the Rg design has to consider the minimum value $I_{OCTH(min)}$ of the threshold as follow:

$$R_g = \frac{I_{OCPx(max)} \cdot R_{SENSE(max)}}{I_{OCTH(min)}}$$

where I_{OCPx} is the current measured by the current reading circuitry when the device enters Quasi-Constant-Current. I_{OCPx} must be calculated starting from the corresponding output current value $I_{OUT(OCP)}$ as follow (I_{D-VID} must also be considered when D-VID are implemented) considering that the device performs Track & Hold only for the LS sense mode:

$$I_{OCPx} = \begin{cases} \frac{I_{OUT(OCP)}}{N} - \frac{\Delta I_{PP}}{2} + \frac{I_{D-VID}}{N} & \text{LowSideMosfetSense} \\ \frac{I_{OUT(OCP)}}{N} + \frac{\Delta I_{PP}}{2} + \frac{I_{D-VID}}{N} & \text{InductorDCRSense} \end{cases}$$

where $I_{OUT(OCP)}$ is still the output current value at which the device enters Quasi-Constant-Current, I_{PP} is the inductor current ripple in each phase I_{D-VID} is the additional current required by D-VID (when applicable) and N the number of phases. In particular, since the device limits the peak or the valley of the inductor current (according to DAC/CS_SEL status), the ripple entity, when not negligible, impacts on the real OC threshold value and must be considered.

18.1 Low side MOSFET sense over current

The device detects an Over Current condition for each phase when the current information I_{INFOX} overcomes the fixed threshold of I_{OCTH} ($35\mu A$ Typ.). When this happens, the device keeps the relative LS MOSFET on, also skipping clock cycles, until the threshold is crossed back and I_{INFOX} results being lower than the I_{OCTH} threshold. After exiting the OC condition, the LS MOSFET is turned off and the HS is turned on with a duty cycle driven by the PWM comparator.

Keeping the LS on, skipping clock cycles, causes the on-time subsequent to the exit from the OC condition, driven by the control loop, to increase. Considering now that the device has a maximum on-time dependence with the delivered current given by the following relationship:

$$T_{ON(max)} = \begin{cases} 0.80 \cdot T_{SW} & I_{DROOP} = 0\mu A \\ 0.40 \cdot T_{SW} & I_{DROOP} = 140\mu A \end{cases}$$

Where I_{OUT} is the output current ($I_{OUT} = \Sigma I_{PHASEx}$) and T_{SW} is the switching period ($T_{SW} = 1/F_{SW}$). This linear dependence has a value at zero load of $0.80 \cdot T_{SW}$ and at maximum current of $0.40 \cdot T_{SW}$ typical.

When the current information I_{INFOX} overcomes the fixed threshold of I_{OCTH} ($35\mu A$ Typ), the device enters in Quasi-Constant-Current operation: the low-side MOSFET stays ON until the current read becomes lower than I_{OCPx} ($I_{INFOX} < I_{OCTH}$) skipping clock cycles. The high side MOSFET can be then turned ON with a T_{ON} imposed by the control loop after the LS turn-off and the device works in the usual way until another OCP event is detected.

This means that the average current delivered can slightly increase in Quasi-Constant-Current operation since the current ripple increases. In fact, the ON time increases due to the OFF time rise because of the current has to reach the I_{OCPx} bottom. The worst-case condition is when the ON time reaches its maximum value.

When this happens, the device works in Constant Current and the output voltage decrease as the load increase. Crossing the UVP threshold causes the device to latch (Figure 20 shows this working condition).

It can be observed that the peak current (I_{PEAK}) is greater than I_{OCPx} but it can be determined as follow:

$$I_{PEAK} = I_{OCPx} + \frac{V_{IN} - V_{OUT(min)}}{L} \cdot T_{ON(max)} = I_{OCPx} + \frac{V_{IN} - V_{OUT(min)}}{L} \cdot 0.40 \cdot T_{SW}$$

Where V_{outMIN} is the UVP threshold, (inductor saturation must be considered). When that threshold is crossed, all MOSFET are turned OFF and the device stops working. Cycle the power supply or the OUTEN pin to restart operation.

The maximum average current during the Constant-Current behavior results:

$$I_{MAX, tot} = N \cdot I_{MAX} = N \cdot \left(I_{OCPx} + \frac{I_{PEAK} - I_{OCPx}}{2} \right)$$

in this particular situation, the switching frequency for each phase results reduced. The ON time is the maximum allowed $T_{ON(max)}$ while the OFF time depends on the application:

$$T_{OFF} = L \cdot \frac{I_{PEAK} - I_{OCPx}}{V_{OUT}} \quad f = \frac{1}{T_{ON(max)} + T_{OFF}}$$

Figure 20. Constant current

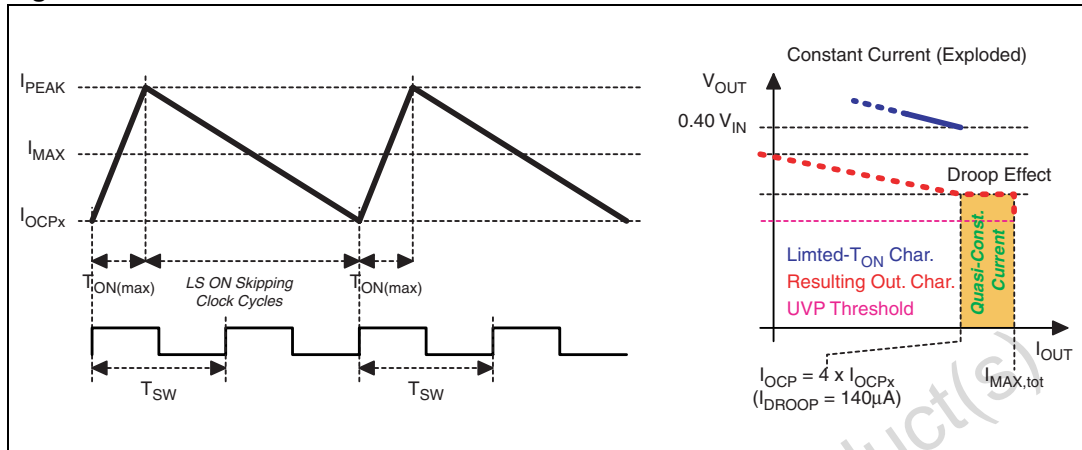

The trans-conductance resistor R_g can be designed considering that the device limits the bottom of the inductor current ripple and also considering the additional current delivered during the quasi-constant-current behavior as previously described in the worst case conditions.

Moreover, when designing D-VID compatible systems, the additional current due to the output filter charge during dynamic VID transitions must be considered.

$$R_g = \frac{I_{OCPx(max)} \cdot R_{SENSE(max)}}{I_{OCTH(min)}}$$

where

$$I_{OCPx} = \frac{I_{OUT(OCP)}}{N} - \frac{\Delta I_{PP}}{2} + \frac{I_{D-VID}}{N}$$

18.2 Inductor sense over current

The device detects an over current when the I_{NFOx} overcome the fixed threshold I_{OCTH} . Since the device always senses the current across the inductor, the I_{OCTH} crossing will happen during the HS conduction time: as a consequence of OCP detection, the device will turn OFF the HS MOSFET and turns ON the LSMOSFET of that phase until I_{NFOx} re-cross the threshold or until the next clock cycle. This implies that the device limits the peak of the inductor current.

In any case, the inductor current won't overcome the I_{OCPx} value and this will represent the maximum peak value to consider in the OC design.

The device works in Constant-Current, and the output voltage decreases as the load increase, until the output voltage reaches the UVP threshold. When this threshold is crossed, all MOSFETs are turned off and the device stops working. Cycle the power supply or the OUTEN pin to restart operation.

The transconductance resistor R_g can be designed considering that the device limits the inductor current ripple peak. Moreover, when designing D-VID systems, the additional current due to the output filter charge during dynamic VID transitions must be considered.

$$R_g = \frac{I_{OCPx(max)} \cdot R_{SENSE(max)}}{I_{OCTH(min)}}$$

where

$$I_{OCPx} = \frac{I_{OUT(OCP)}}{N} + \frac{\Delta I_{PP}}{2} + \frac{I_{D-VID}}{N}$$

19 Oscillator

L6714 embeds four phase oscillator with optimized phase-shift (90° phase-shift) in order to reduce the input rms current and optimize the output filter definition.

The internal oscillator generates the triangular waveform for the PWM charging and discharging with a constant current an internal capacitor. The switching frequency for each channel, F_{SW} , is internally fixed at 150kHz so that the resulting switching frequency at the load side results in being multiplied by N (number of phases).

The current delivered to the oscillator is typically 25μA (corresponding to the free running frequency $F_{SW} = 150\text{kHz}$) and it may be varied using an external resistor (R_{OSC}) connected between the OSC pin and SGND or VCC (or a fixed voltage greater than 1.24V). Since the OSC pin is fixed at 1.24V, the frequency is varied proportionally to the current sunk (forced) from (into) the pin considering the internal gain of 6KHz/μA.

In particular connecting R_{OSC} to SGND the frequency is increased (current is sunk from the pin), while connecting R_{OSC} to VCC = 12V the frequency is reduced (current is forced into the pin), according the following relationships:

R_{OSC} vs. SGND

$$F_{SW} = 150(\text{kHz}) + \frac{1.240\text{V}}{R_{OSC}(\text{k}\Omega)} \cdot 6 \frac{\text{kHz}}{\mu\text{A}} = 150(\text{kHz}) + \frac{7.422 \cdot 10^3}{R_{OSC}(\text{k}\Omega)}$$

$$\frac{1}{F_{SW}(\text{kHz}) - 150(\text{kHz})} \Rightarrow R_{OSC}(\text{k}\Omega) = \frac{7.422 \cdot 10^3}{F_{SW}(\text{kHz}) - 150(\text{kHz})} [\text{k}\Omega]$$

R_{OSC} vs. +12V

$$F_{SW} = 150(\text{kHz}) - \frac{12\text{V} - 1.240\text{V}}{R_{OSC}(\text{k}\Omega)} \cdot 6 \frac{\text{kHz}}{\mu\text{A}} = 150(\text{kHz}) - \frac{6.456 \cdot 10^4}{R_{OSC}(\text{k}\Omega)}$$

$$\frac{1}{150(\text{kHz}) - F_{SW}(\text{kHz})} \Rightarrow R_{OSC}(\text{k}\Omega) = \frac{6.456 \cdot 10^4}{150(\text{kHz}) - F_{SW}(\text{kHz})} [\text{k}\Omega]$$

When using the Low-Side MOSFETs current sense, the maximum programmable switching frequency per phase must be limited to 500kHz to avoid current reading errors causing, as a consequence, current sharing errors.

Anyway, device power dissipation must be checked prior to design high switching frequency systems.

Figure 21. R_{OSC} vs. switching frequency

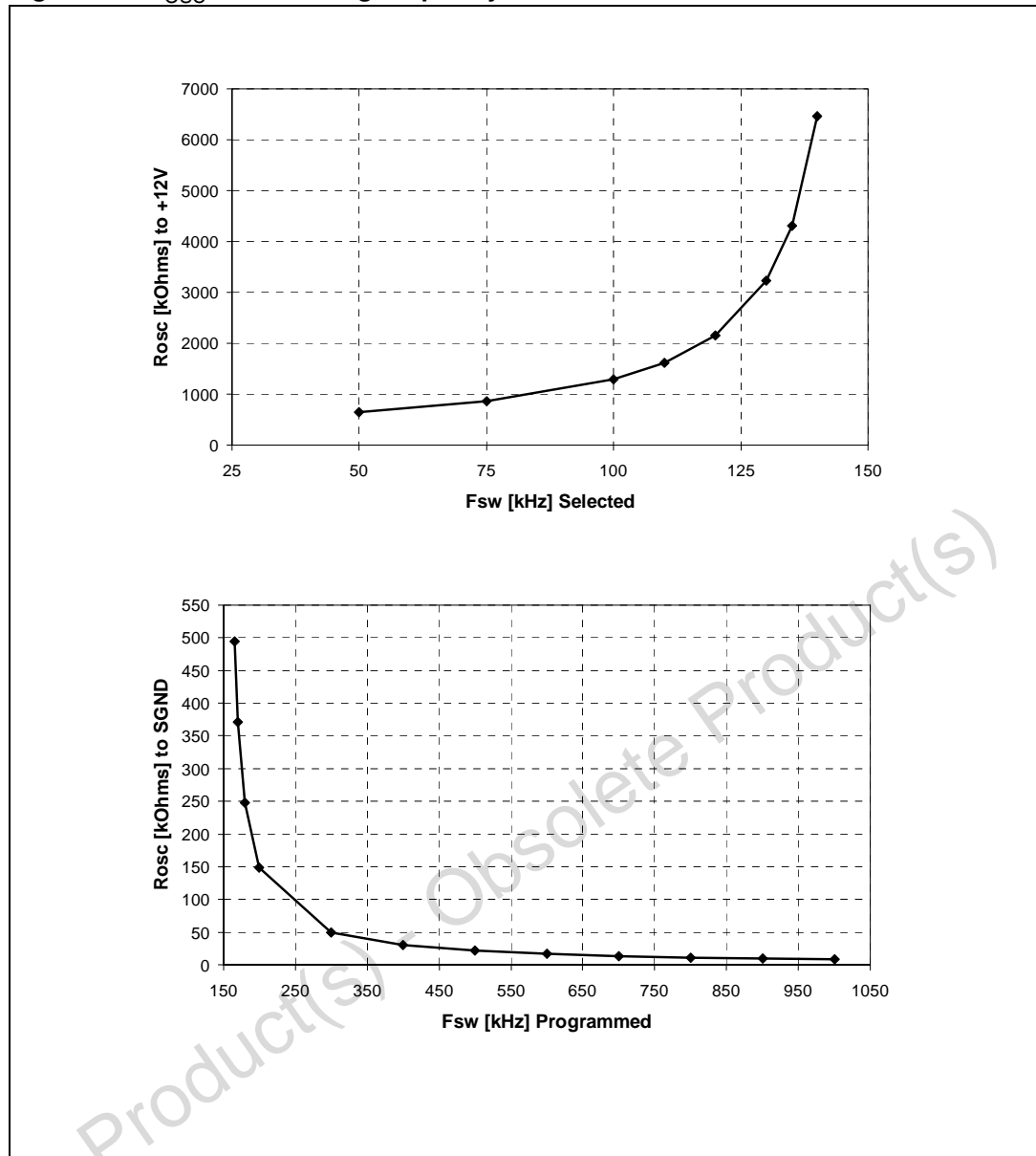

Obsolete Product(s)

20 Driver section

The integrated high-current drivers allow using different types of power MOS (also multiple MOS to reduce the equivalent R_{dsON}), maintaining fast switching transition.

The drivers for the high-side MOSFETs use BOOTx pins for supply and PHASEx pins for return. The drivers for the low-side MOSFETs use VCCDRx pin for supply and PGNDx pin for return. A minimum voltage at VCCDRx pin is required to start operations of the device. VCCDRx pins must be connected together.

The controller embodies a sophisticated anti-shoot-through system to minimize low side body diode conduction time maintaining good efficiency saving the use of Schottky diodes: when the high-side MOSFET turns off, the voltage on its source begins to fall; when the voltage reaches 2V, the low-side MOSFET gate drive is suddenly applied. When the low-side MOSFET turns off, the voltage at LGATEx pin is sensed. When it drops below 1V, the high-side MOSFET gate drive is suddenly applied.

If the current flowing in the inductor is negative, the source of high-side MOSFET will never drop. To allow the turning on of the low-side MOSFET even in this case, a watchdog controller is enabled: if the source of the high-side MOSFET doesn't drop, the low side MOSFET is switched on so allowing the negative current of the inductor to recirculate. This mechanism allows the system to regulate even if the current is negative.

The BOOTx and VCCDRx pins are separated from IC's power supply (VCC pin) as well as signal ground (SGND pin) and power ground (PGNDx pin) in order to maximize the switching noise immunity. The separated supply for the different drivers gives high flexibility in MOSFET choice, allowing the use of logic-level MOSFET. Several combination of supply can be chosen to optimize performance and efficiency of the application.

Power conversion input is also flexible; 5V, 12V bus or any bus that allows the conversion (See maximum duty cycle limitations) can be chosen freely.

21 System control loop compensation

The control loop is composed by the Current Sharing control loop (See Figure 8) and the Average Current Mode control loop. Each loop gives, with a proper gain, the correction to the PWM in order to minimize the error in its regulation: the Current Sharing control loop equalize the currents in the inductors while the Average Current Mode control loop fixes the output voltage equal to the reference programmed by VID. Figure 22 shows the block diagram of the system control loop.

The system Control Loop is reported in Figure 23. The current information I_{DROOP} sourced by the DROOP pin flows into R_{FB} implementing the dependence of the output voltage from the read current.

Figure 22. Main control loop

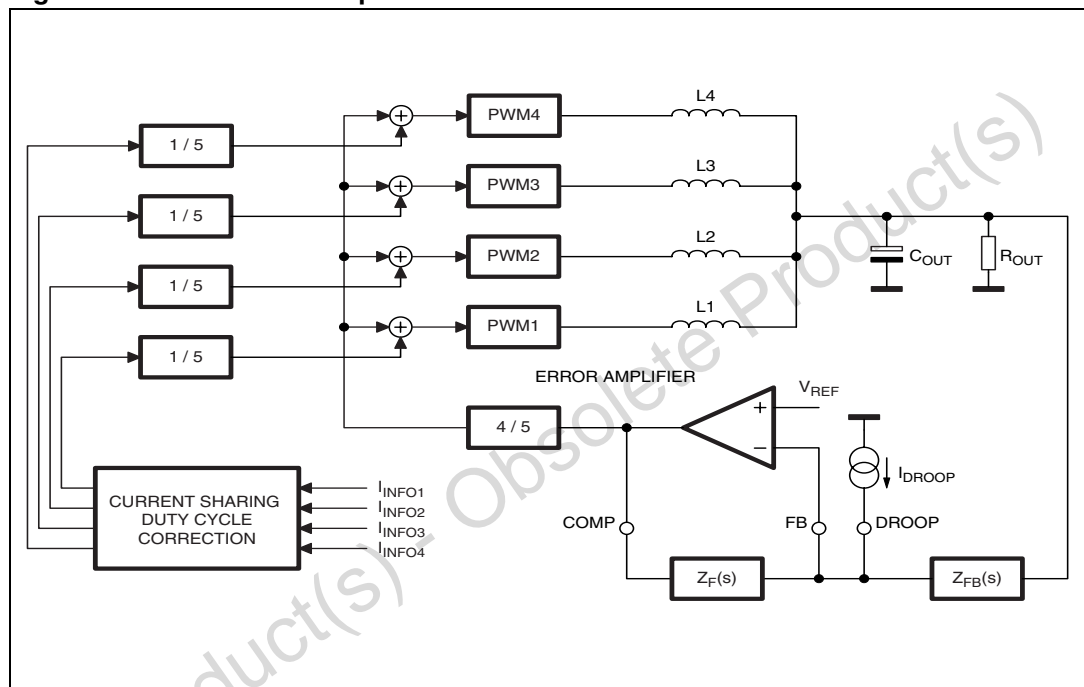

The system can be modeled with an equivalent single phase converter which only difference is the equivalent inductor L/N (where each phase has an L inductor). The Control Loop gain results (obtained opening the loop after the COMP pin):

$$G_{LOOP}(s) = \frac{PWM \cdot Z_F(s) \cdot (R_{DROOP} + Z_P(s))}{[Z_P(s) + Z_L(s)] \cdot \left[\frac{Z_F(s)}{A(s)} + \left(1 + \frac{1}{A(s)}\right) \cdot R_{FB} \right]}$$

Where:

- R_{SENSE} is the MOSFET R_{dsON} or the Inductor DCR depending on the sensing element selected;
- $R_{DROOP} = \frac{R_{SENSE}}{R_g}$. R_{FB} is the equivalent output resistance determined by the droop function;
- $Z_p(s)$ is the impedance resulting by the parallel of the output capacitor (and its ESR) and the applied load R_O ;
- $Z_F(s)$ is the compensation network impedance;
- $Z_L(s)$ is the parallel of the N inductor impedance;
- $A(s)$ is the error amplifier gain;
- $PWM = \frac{4}{5} \cdot \frac{V_{IN}}{\Delta V_{OSC}}$ is the PWM transfer function where ΔV_{OSC} is the oscillator ramp amplitude and has a typical value of 4V.

Removing the dependence from the Error Amplifier gain, so assuming this gain high enough, and with further simplifications, the control loop gain results:

$$G_{LOOP}(s) = \frac{4}{5} \cdot \frac{V_{IN}}{\Delta V_{OSC}} \cdot \frac{Z_F(s)}{R_{FB}} \cdot \frac{R_O + R_{DROOP}}{R_O + \frac{R_L}{N}} \cdot \frac{1 + s \cdot C_O \cdot (R_{DROOP} // R_O + ESR)}{s^2 \cdot C_O \cdot \frac{L}{N} + s \cdot \left[\frac{L}{N \cdot R_O} + C_O \cdot ESR + C_O \cdot \frac{R_L}{N} \right] + 1}$$

The system Control Loop gain (See Figure 23) is designed in order to obtain a high DC gain to minimize static error and to cross the 0dB axes with a constant -20dB/dec slope with the desired crossover frequency ω_T . Neglecting the effect of $Z_F(s)$, the transfer function has one zero and two poles; both the poles are fixed once the output filter is designed (LC filter resonance ω_{LC}) and the zero (ω_{ESR}) is fixed by ESR and the Droop resistance.

Figure 23. Equivalent control loop block diagram (left) and bode diagram (right).

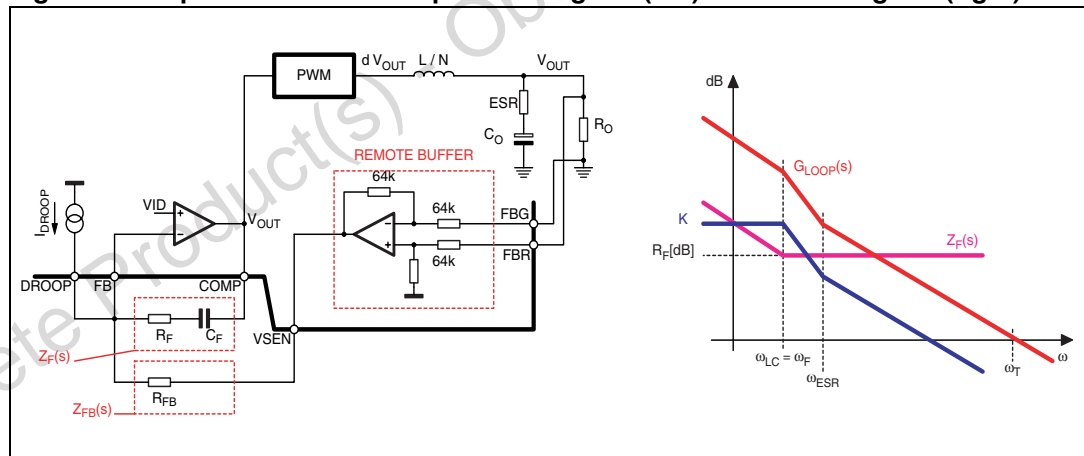

To obtain the desired shape an $R_F - C_F$ series network is considered for the $Z_F(s)$ implementation. A zero at $\omega_F = 1/R_F C_F$ is then introduced together with an integrator. This integrator minimizes the static error while placing the zero ω_F in correspondence with the LC resonance assures a simple -20dB/dec shape of the gain.

In fact, considering the usual value for the output filter, the LC resonance results to be at frequency lower than the above reported zero.

Compensation network can be simply designed placing $\omega_F = \omega_{LC}$ and imposing the cross-over frequency ω_T as desired obtaining (always considering that ω_T might be not higher than 1/10th of the switching frequency F_{SW}):

$$R_F = \frac{R_{FB} \cdot \Delta V_{OSC}}{V_{IN}} \cdot \frac{5}{4} \cdot \omega_T \cdot \frac{L}{N \cdot (R_{DROOP} + ESR)}$$

$$C_F = \frac{\sqrt{C_O \cdot \frac{L}{N}}}{R_F}$$

21.1 Compensation network guidelines

The Compensation Network design assures to having system response according to the cross-over frequency selected and to the output filter considered: it is anyway possible to further fine-tune the compensation network modifying the bandwidth in order to get the best response of the system as follow (See Figure 24):

- Increase R_F to increase the system bandwidth accordingly;
- Decrease R_F to decrease the system bandwidth accordingly;
- Increase C_F to move ω_F to low frequencies increasing as a consequence the system phase margin.

Having the fastest compensation network gives not the confidence to satisfy the requirements of the load: the inductor still limits the maximum di/dt that the system can afford. In fact, when a load transient is applied, the best that the controller can do is to “saturate” the duty cycle to its maximum (d_{MAX}) or minimum (0) value. The output voltage dV/dt is then limited by the inductor charge / discharge time and by the output capacitance. In particular, the most limiting transition corresponds to the load removal since the inductor results being discharged only by V_{OUT} (while it is charged by $d_{MAX}V_{IN} - V_{OUT}$ during a load appliance).

Referring to Figure 24-left, further tuning the Compensation network cannot give any improvements unless the output filter changes: only modifying the main inductors of the output capacitance improves the system response.

Figure 24. R_F - C_F impact on bandwidth.

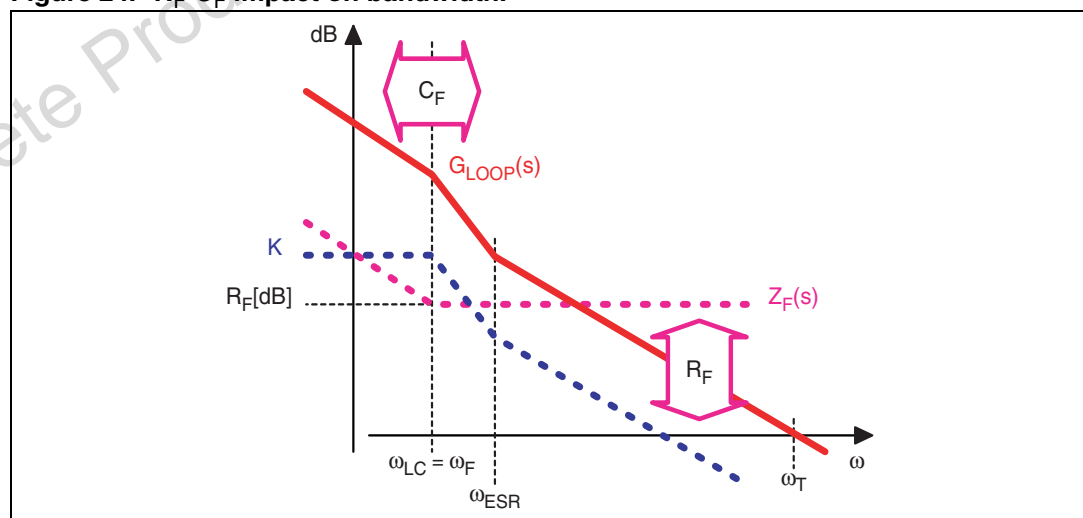

22 Thermal monitor

L6714 continuously senses the system temperature through TM pin: depending on the voltage sensed by this pin, the device sets free the VR_FAN pin as a warning and, after further temperature increase, also the VR_HOT pin as an alarm condition.

These signals can be used to give a boost to the system fan (VR_FAN) and improve the VR cooling, or to initiate the CPU low power state (VR_HOT) in order to reduce the current demand from the processor so reducing also the VR temperature. In a different manner, VR_FAN can be used to initiate the CPU low power state so reducing the processor current requirements and VR_HOT to reset the system in case of further dangerous temperature increase.

Thermal sensors is external to the PWM control IC since the controller is normally not located near the heat generating components: it is basically composed by a NTC resistor and a proper biasing resistor R_{TM} . NTC must be connected as close as possible at the system hot-spot in order to be sure to control the hottest point of the VR.

Typical connection is reported in Figure 25 that also shows how the trip point can be easily programmed by modifying the divider values in order to cross the VR_FAN and VR_HOT thresholds at the desired temperatures.

Both VR_HOT and VR_FAN are active high and open drain outputs. Thermal Monitoring Output are enabled if $V_{CC} > UVLO_{VCC}$.

Figure 25. System thermal monitor typical connections.

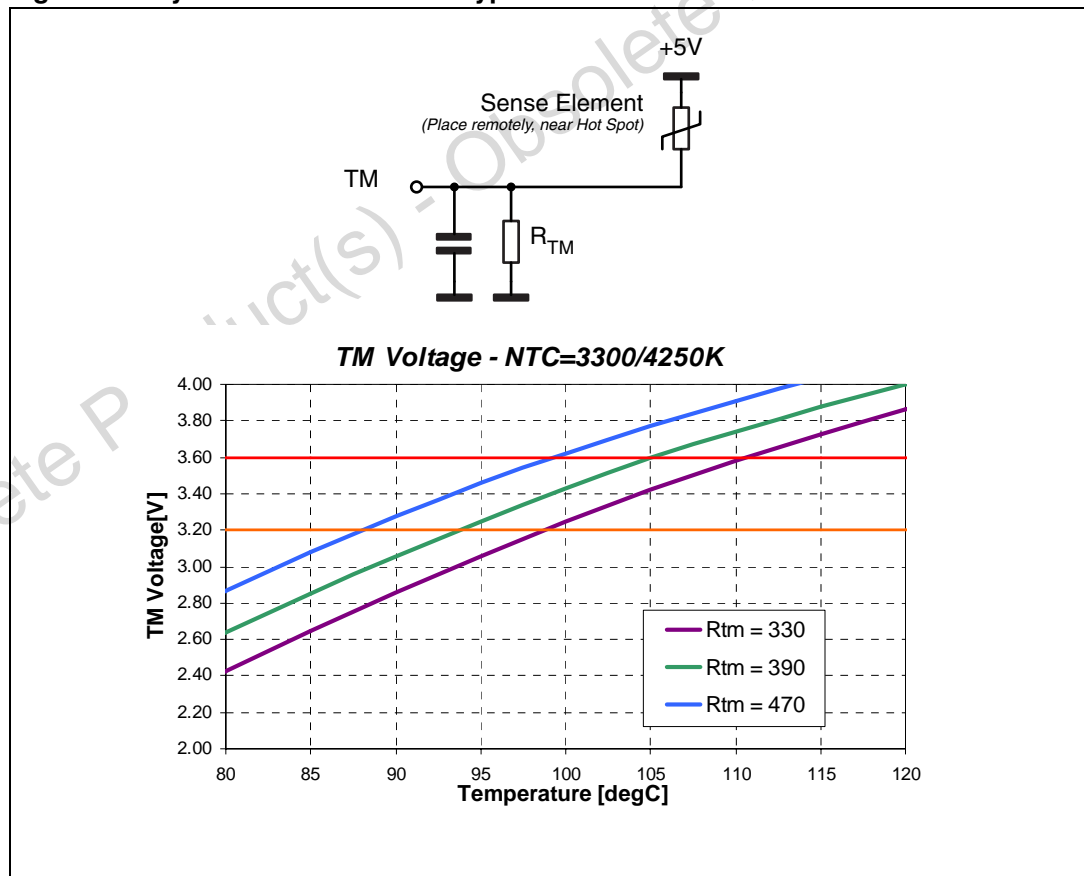

23 Tolerance band (TOB) definition

Output voltage load-line varies considering component process variation, system temperature extremes, and age degradation limits. Moreover, individual tolerance of the components also varies among designs: it is then possible to define a Manufacturing Tolerance Band (TOB_{Manuf}) that defines the possible output voltage spread across the nominal load line characteristic.

TOB_{Manuf} can be sliced into different three main categories: Controller Tolerance, External Current Sense Circuit Tolerance and Time Constant Matching Error Tolerance. All these parameters can be composed thanks to the RSS analysis so that the manufacturing variation on TOB results to be:

$$TOB_{\text{Manuf}} = \sqrt{TOB_{\text{Controller}}^2 + TOB_{\text{CurrSense}}^2 + TOB_{\text{TCMatching}}^2}$$

Output voltage ripple ($V_P = V_{PP}/2$) and temperature measurement error (V_{TC}) must be added to the Manufacturing TOB in order to get the system Tolerance Band as follow:

$$TOB = TOB_{\text{Manuf}} + V_P + V_{TC}$$

All the component spreads and variations are usually considered at 3σ . Here follows an explanation on how to calculate these parameters for a reference L6714 application.

23.1 Controller tolerance (TOB controller)

It can be further sliced as follow:

- Reference tolerance. L6714 is trimmed during the production stage to ensure the output voltage to be within $k_{VID} = \pm 0.5\%$ ($\pm 0.6\%$ for AMD DAC) over temperature and line variations. In addition, the device automatically adds a -19mV offset (Only for Intel Mode) avoiding the use of any external component. This offset is already included during the trimming process in order to avoid the use of any external circuit to generate this offsets and, moreover, avoiding the introduction of any further error to be considered in the TOB calculation.
- Current Reading Circuit. The device reads the current flowing across the MOSFET R_{dsON} or the inductor DCR by using its dedicated differential inputs. The current sourced by the VRD is then reproduced and sourced from the DROOP pin scaled down by a proper designed gain as follow:

$$I_{\text{DROOP}} = \frac{R_{\text{SENSE}}}{R_g} \cdot I_{\text{OUT}}$$

This current multiplied by the R_{FB} resistor connected from FB pin vs. the load allows programming the droop function according to the selected R_L/R_g gain and R_{FB} resistor. Deviations in the current sourced due to errors in the current reading, impacts on the output voltage depending on the size of R_{FB} resistor. The device is trimmed during the production stage in order to guarantee a maximum deviation of $k_{\text{IFB}} = \pm 1\mu\text{A}$ from the nominal value.

Controller tolerance results then to be:

$$TOB_{\text{Controller}} = \sqrt{[(VID - 19\text{mV}) \cdot k_{VID}]^2 + (k_{\text{IDROOP}} \cdot R_{\text{FB}})^2}$$

23.2 Ext. current sense circuit tolerance (TOB CurrSense - Inductor Sense)

It can be further sliced as follow:

- Inductor DCR Tolerance (k_{DCR}). Variations in the inductor DCR impacts on the output voltage since the device reads a current that is different from the real current flowing into the sense element. As a results, the controller will source a I_{DROOP} current different from the nominal. The results will be an AVP different from the nominal in the same percentage as the DCR is different from the nominal. Since all the sense elements results to be in parallel, the error related to the inductor DCR has to be divided by the number of phases (N).
- Trans-conductance resistors tolerance (k_{Rg}). Variations in the Rg resistors impacts in the current reading circuit gain and so impacts on the output voltage. The results will be an AVP different from the nominal in the same percentage as the Rg is different from the nominal. Since all the sense elements results to be in parallel, and so the three current reading circuits, the error related to the Rg resistors has to be divided by the number of phases (N).
- NTC Initial Accuracy (k_{NTC_0}). Variations in the NTC nominal value at room temperature used for the thermal compensation impacts on the AVP in the same percentage as before. In addition, the benefit of the division by the number of phases N cannot be applied in this case.
- NTC Temperature Accuracy (k_{NTC}). NTC variations from room to hot also impacts on the output voltage positioning. The impact is bigger as big is the temperature variation from room to hot (ΔT).
- All these parameters impacts the AVP, so they must be weighted on the maximum voltage swing from zero load up to the maximum electrical current (V_{AVP}). Total error from external current sense circuit results:

$$TOB_{CurrSense} = \sqrt{V_{AVP}^2 \cdot \left[\frac{k_{DCR}^2}{N} + \frac{k_{Rg}^2}{N} + k_{NTC0}^2 + \left(\frac{\alpha \cdot \Delta T \cdot k_{NTC}}{DCR} \right)^2 \right]}$$

23.3 Time constant matching error tolerance (TOB TCMatching)

- Inductance and capacitance Tolerance (k_L , k_C). Variations in the inductance value and in the value of the capacitor used for the Time Constant Matching causes over/under shoots after a load transient appliance. This impacts the output voltage and then the TOB. Since all the sense elements results to be in parallel, the error related to the time constant mismatch has to be divided by the number of phases (N).
- Capacitance Temperature Variations (k_{Ct}). The capacitor used for time constant matching also vary with temperature (ΔT_C) impacting on the output voltage transients ad before. Since all the sense elements results to be in parallel, the error related to the time constant mismatch has to be divided by the number of phases (N).
- All these parameters impact the Dynamic AVP, so they must be weighted on the maximum dynamic voltage swing (I_{dyn}). Total error due to time constant mismatch results:

$$TOB_{TCMatching} = \sqrt{V_{AVPDyn}^2 \cdot \frac{k_L^2 + k_C^2 + (k_{Ct} \cdot \Delta TC)}{N}}$$

23.4 Temperature measurement error (V_{TC})

Error in the measured temperature (for thermal compensation) impacts on the output regulated voltage since the correction form the compensation circuit is not what required to keep the output voltage flat.

The measurement error (ϵ_{Temp}) must be multiplied by the copper temp coefficient (α) and compared with the sensing resistance (R_{SENSE}): this percentage affects the AVP voltage as follow:

$$V_{TC} = \frac{\alpha \cdot \epsilon_{Temp}}{R_{SENSE}} \cdot V_{AVP}$$

24 Layout guidelines

Since the device manages control functions and high-current drivers, layout is one of the most important things to consider when designing such high current applications. A good layout solution can generate a benefit in lowering power dissipation on the power paths, reducing radiation and a proper connection between signal and power ground can optimize the performance of the control loops.

Two kind of critical components and connections have to be considered when laying out a VRM based on L6714: power components and connections and small signal components connections.

24.1 Power components and connections

These are the components and connections where switching and high continuous current flows from the input to the load. The first priority when placing components has to be reserved to this power section, minimizing the length of each connection and loop as much as possible. To minimize noise and voltage spikes (EMI and losses) these interconnections must be a part of a power plane and anyway realized by wide and thick copper traces: loop must be anyway minimized. The critical components, i.e. the power transistors, must be close one to the other. The use of multi-layer printed circuit board is recommended.

Figure 26 shows the details of the power connections involved and the current loops. The input capacitance (C_{IN}), or at least a portion of the total capacitance needed, has to be placed close to the power section in order to eliminate the stray inductance generated by the copper traces. Low ESR and ESL capacitors are preferred, MLCC are suggested to be connected near the HS drain.

Use proper VIAs number when power traces have to move between different planes on the PCB in order to reduce both parasitic resistance and inductance. Moreover, reproducing the same high-current trace on more than one PCB layer will reduce the parasitic resistance associated to that connection.

Connect output bulk capacitor as near as possible to the load, minimizing parasitic inductance and resistance associated to the copper trace also adding extra decoupling capacitors along the way to the load when this results in being far from the bulk capacitor bank.

Gate traces must be sized according to the driver RMS current delivered to the power MOSFET. The device robustness allows managing applications with the power section far from the controller without losing performances. External gate resistors help the device to dissipate power resulting in a general cooling of the device. When driving multiple MOSFETs in parallel, it is suggested to use one resistor for each MOSFET.

24.2 Small signal components and connections

These are small signal components and connections to critical nodes of the application as well as bypass capacitors for the device supply (See Figure 26). Locate the bypass capacitor (VCC, VCCDRx and Bootstrap capacitor) close to the device and refer sensible components such as frequency set-up resistor R_{OSC} , offset resistor R_{OFFSET} and OVP resistor R_{OVP} to SGND. Star grounding is suggested: connect SGND to PGND plane in a single point to avoid that drops due to the high current delivered causes errors in the device behavior.

VSEN pin filtered vs. SGND helps in reducing noise injection into device and OUTEN pin filtered vs. SGND helps in reducing false trip due to coupled noise: take care in routing driving net for this pin in order to minimize coupled noise.

Warning: Boot Capacitor Extra Charge. Systems that do not use Schottky diodes might show big negative spikes on the phase pin. This spike can be limited as well as the positive spike but has an additional consequence: it causes the bootstrap capacitor to be over-charged. This extra-charge can cause, in the worst case condition of maximum input voltage and during particular transients, that boot-to-phase voltage overcomes the abs. max. ratings also causing device failures. It is then suggested in this cases to limit this extra-charge by adding a small resistor in series to the boot diode (one resistor can be enough for all the three diodes if placed upstream the diode anode, See Figure 26) and by using standard and low-capacitive diodes.

Figure 26. Power connections and related connections layout (same for all phases).

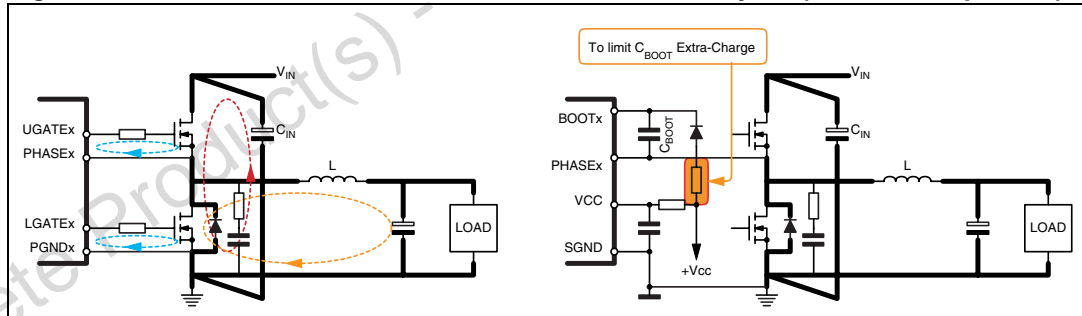

Remote Buffer Connection must be routed as parallel nets from the FBG/FBR pins to the load in order to avoid the pick-up of any common mode noise. Connecting these pins in points far from the load will cause a non-optimum load regulation, increasing output tolerance.

Locate current reading components close to the device. The PCB traces connecting the reading point must use dedicated nets, routed as parallel traces in order to avoid the pick-up of any common mode noise. It's also important to avoid any offset in the measurement and, to get a better precision, to connect the traces as close as possible to the sensing elements. Symmetrical layout is also suggested. Small filtering capacitor can be added, near the controller, between V_{OUT} and SGND, on the CSx- line when reading across inductor to allow higher layout flexibility.

25 Embedding L6714 - Based VR

When embedding the VRD into the application, additional care must be taken since the whole VRD is a switching DC/DC regulator and the most common system in which it has to work is a digital system such as MB or similar. In fact, latest MB has become faster and powerful: high speed data bus are more and more common and switching-induced noise produced by the VRD can affect data integrity if not following additional layout guidelines. Few easy points must be considered mainly when routing traces in which high switching currents flow (high switching currents cause voltage spikes across the stray inductance of the trace causing noise that can affect the near traces):

Keep safe guarding distance between high current switching VRD traces and data buses, especially if high-speed data bus to minimize noise coupling.

Keep safe guard distance or filter properly when routing bias traces for I/O sub-systems that must walk near the VRD.

Possible causes of noise can be located in the PHASE connections, MOSFET gate drive and Input voltage path (from input bulk capacitors and HS drain). Also PGND connections must be considered if not insisting on a power ground plane. These connections must be carefully kept far away from noise-sensitive data bus.

Since the generated noise is mainly due to the switching activity of the VRM, noise emissions depend on how fast the current switches. To reduce noise emission levels, it is also possible, in addition to the previous guidelines, to reduce the current slope by properly tuning the HS gate resistor and the PHASE snuber network.

26 Package mechanical data

In order to meet environmental requirements, ST offers these devices in ECOPACK[®] packages. These packages have a Lead-free second level interconnect. The category of second Level Interconnect is marked on the package and on the inner box label, in compliance with JEDEC Standard JESD97. The maximum ratings related to soldering conditions are also marked on the inner box label. ECOPACK is an ST trademark. ECOPACK specifications are available at: www.st.com.

Obsolete Product(s) - Obsolete Product(s)

Table 13. TQFP64 mechanical data

Dim.	mm.			inch		
	Min	Typ	Max	Min	Typ	Max
A			1.20			0.0472
A1	0.05		0.15	0.002		0.006
A2	0.95	1.00	1.05	0.0374	0.0393	0.0413
b	0.17	0.22	0.27	0.0066	0.0086	0.0086
c	0.09		0.20	0.0035		0.0078
D	11.80	12.00	12.20	0.464	0.472	0.480
D1	9.80	10.00	10.20	0.386	0.394	0.401
D2	3.50		6.10	0.1378		0.2402
D3		7.50			0.295	
E	11.80	12.00	12.20	0.464	0.472	0.480
E1	9.80	10.00	10.20	0.386	0.394	0.401
E2	3.50		6.10	0.1378		0.2402
E3		7.50			0.295	
e		0.50			0.0197	
L	0.45	0.60	0.75	0.0177	0.0236	0.0295
L1		1.00			0.0393	
k	0°	3.5°	7°	0°	3.5°	7°
ccc			0.080			0.0031

Figure 27. Package dimensions

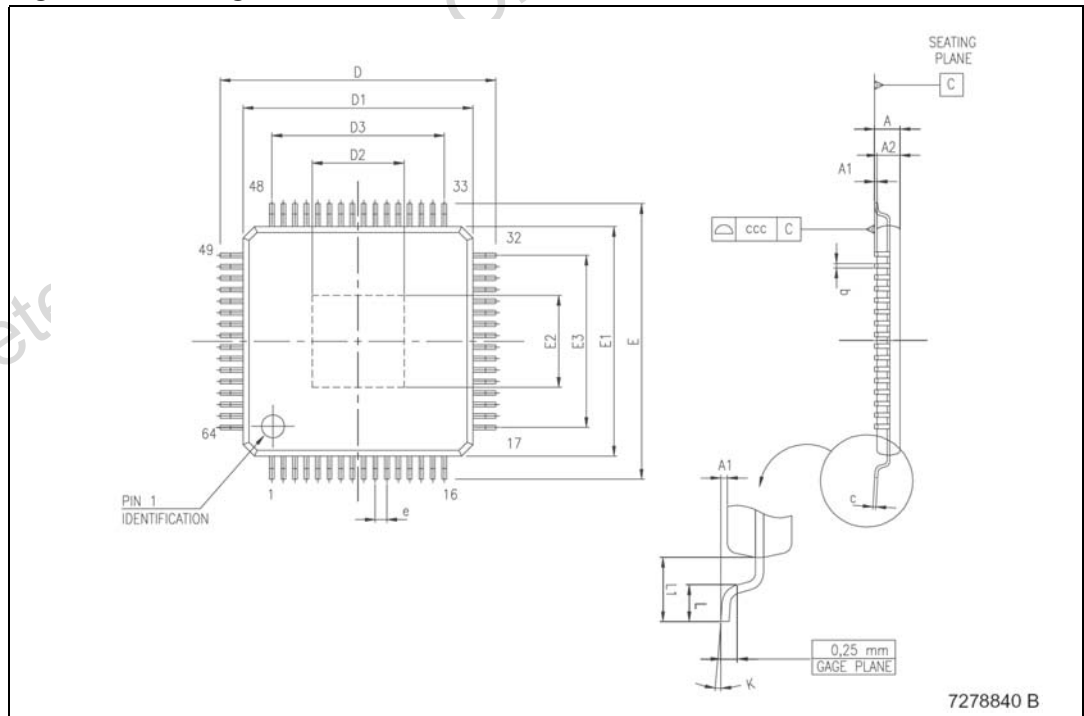

27 Revision history

Table 14. Revision history

Date	Revision	Changes
16-Mar-2006	1	Initial release.
02-Aug-2006	2	Updated K_{IDROOP} $K_{IOFFSET}$ values in Table 4: Electrical characteristics on page 14 .
07-Nov-2006	3	Updated D2 and E2 exposed tab measures in Table 13: TQFP64 mechanical data .

Obsolete Product(s) - Obsolete Product(s)

Please Read Carefully:

Information in this document is provided solely in connection with ST products. STMicroelectronics NV and its subsidiaries ("ST") reserve the right to make changes, corrections, modifications or improvements, to this document, and the products and services described herein at any time, without notice.

All ST products are sold pursuant to ST's terms and conditions of sale.

Purchasers are solely responsible for the choice, selection and use of the ST products and services described herein, and ST assumes no liability whatsoever relating to the choice, selection or use of the ST products and services described herein.

No license, express or implied, by estoppel or otherwise, to any intellectual property rights is granted under this document. If any part of this document refers to any third party products or services it shall not be deemed a license grant by ST for the use of such third party products or services, or any intellectual property contained therein or considered as a warranty covering the use in any manner whatsoever of such third party products or services or any intellectual property contained therein.

UNLESS OTHERWISE SET FORTH IN ST'S TERMS AND CONDITIONS OF SALE ST DISCLAIMS ANY EXPRESS OR IMPLIED WARRANTY WITH RESPECT TO THE USE AND/OR SALE OF ST PRODUCTS INCLUDING WITHOUT LIMITATION IMPLIED WARRANTIES OF MERCHANTABILITY, FITNESS FOR A PARTICULAR PURPOSE (AND THEIR EQUIVALENTS UNDER THE LAWS OF ANY JURISDICTION), OR INFRINGEMENT OF ANY PATENT, COPYRIGHT OR OTHER INTELLECTUAL PROPERTY RIGHT.

UNLESS EXPRESSLY APPROVED IN WRITING BY AN AUTHORIZED ST REPRESENTATIVE, ST PRODUCTS ARE NOT RECOMMENDED, AUTHORIZED OR WARRANTED FOR USE IN MILITARY, AIR CRAFT, SPACE, LIFE SAVING, OR LIFE SUSTAINING APPLICATIONS, NOR IN PRODUCTS OR SYSTEMS WHERE FAILURE OR MALFUNCTION MAY RESULT IN PERSONAL INJURY, DEATH, OR SEVERE PROPERTY OR ENVIRONMENTAL DAMAGE. ST PRODUCTS WHICH ARE NOT SPECIFIED AS "AUTOMOTIVE GRADE" MAY ONLY BE USED IN AUTOMOTIVE APPLICATIONS AT USER'S OWN RISK.

Resale of ST products with provisions different from the statements and/or technical features set forth in this document shall immediately void any warranty granted by ST for the ST product or service described herein and shall not create or extend in any manner whatsoever, any liability of ST.

ST and the ST logo are trademarks or registered trademarks of ST in various countries.

Information in this document supersedes and replaces all information previously supplied.

The ST logo is a registered trademark of STMicroelectronics. All other names are the property of their respective owners.

© 2006 STMicroelectronics - All rights reserved

STMicroelectronics group of companies

Australia - Belgium - Brazil - Canada - China - Czech Republic - Finland - France - Germany - Hong Kong - India - Israel - Italy - Japan - Malaysia - Malta - Morocco - Singapore - Spain - Sweden - Switzerland - United Kingdom - United States of America

www.st.com



Looking for pricing, stock, or lifecycle information?

Click below to explore more details on WIN SOURCE:

 [View L6714TR](#) on WIN SOURCE

 [STMicroelectronics](#) Information

Optimize Your Supply Chain with WIN SOURCE Solutions

-  Global Sourcing Solution
-  Obsolete Management
-  Cost Control Management
-  Shortage Management
-  Alternative Solution
-  Excess Inventory Management