



THE DATASHEET OF L6716TR



2/3/4 phase controller with embedded drivers for Intel® VR11.1

Features

- Load transient boost LTB Technology™ to minimize the number of output capacitors
- 2 or 3-phase operation with internal driver
- 4-phase operation with external PWM driver signal
- PSI input with programmable strategy
- Imon output
- 0.5% output voltage accuracy
- 8-bit programmable output up to 1.60000 V - Intel VR11.1 DAC - backward compatible with VR10/VR11
- Full differential current sense across inductor
- Differential remote voltage sensing
- Adjustable voltage offset
- LSLess startup to manage pre-biased output
- Feedback disconnection protection
- Preliminary overvoltage protection
- Programmable overcurrent protection
- Programmable overvoltage protection
- Adjustable switching frequency
- SS_END and OUTEN signal
- VFQFPN-48 7x7 mm package with exposed pad

Applications

- High current VRM/VRD for desktop / server / workstation CPUs
- High density DC/DC converters

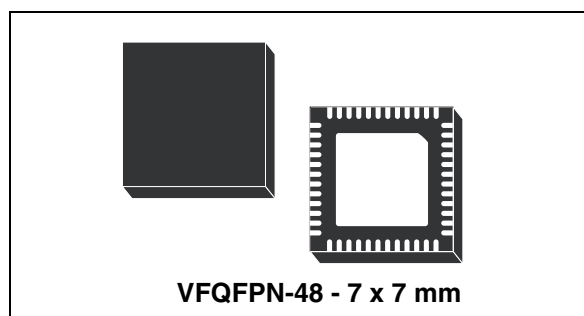

Description

The device implements a two-to-four phases step-down controller with three integrated high current drivers in a compact 7x7 mm body package with exposed pad.

Load transient boost LTB Technology™ reduces system cost by providing the fastest response to load transition therefore requiring less bulk and ceramic output capacitors to satisfy load transient requirements.

The device embeds VR11.x DACs: the output voltage ranges up to 1.60000 V managing D-VID with $\pm 0.5\%$ output voltage accuracy over line and temperature variations.

The controller assures fast protection against load overcurrent and under / overvoltage (in this last case also before UVLO). Feedback disconnection prevents from damaging the load in case of disconnections in the system board.

In case of overcurrent, the system works in constant current mode until UVP.

Table 1. Device summary

Order codes	Package	Packing
L6716	VFQFPN-48	Tray
L6716TR		Tape and reel

Contents

- 1 Principle application circuit and block diagram 4**
 - 1.1 Principle application circuit 4
 - 1.2 Block diagram 7
- 2 Pin description and connection diagram 8**
 - 2.1 Pin description 8
- 3 Maximum ratings 13**
 - 3.1 Absolute maximum ratings 13
 - 3.2 Thermal data 13
- 4 Electrical characteristics 14**
 - 4.1 Electrical characteristics 14
- 5 Voltage identifications 17**
- 6 Device description 20**
- 7 DAC and Phase number selection 21**
- 8 Power dissipation 22**
- 9 Current reading and current sharing loop 23**
- 10 Differential remote voltage sensing 25**
- 11 Voltage positioning 26**
 - 11.1 Offset (optional) 26
 - 11.2 Droop function 27
- 12 Droop thermal compensation 28**
- 13 Output current monitoring (IMON) 29**
- 14 Load transient boost technology 31**

15	Dynamic VID transitions	33
16	Enable and disable	35
17	Soft-start	36
	17.1 Low-side-less startup	38
18	Output voltage monitor and protections	39
	18.1 Undervoltage	39
	18.2 Preliminary overvoltage	39
	18.3 Overvoltage and programmable OVP	40
	18.4 Overcurrent protection	41
	18.5 Feedback disconnection	43
19	Low power state management and PSI#	44
20	Oscillator	45
21	Driver section	46
22	System control loop compensation	47
23	Tolerance band (TOB) definition	49
	23.1 Controller tolerance (TOBController)	49
	23.2 External current sense circuit tolerance (TOBCurrSense)	50
	23.3 Time constant matching error tolerance (TOBTCMatching)	50
	23.4 Temperature measurement error (VTC)	51
24	Layout guidelines	52
	24.1 Power components and connections	52
	24.2 Small signal components and connections	53
25	Embedding L6716 - based VR	54
26	Package mechanical data	55
27	Revision history	56

1 Principle application circuit and block diagram

1.1 Principle application circuit

Figure 1. Principle application circuit for VR11.1 - 2 phase operation (a)

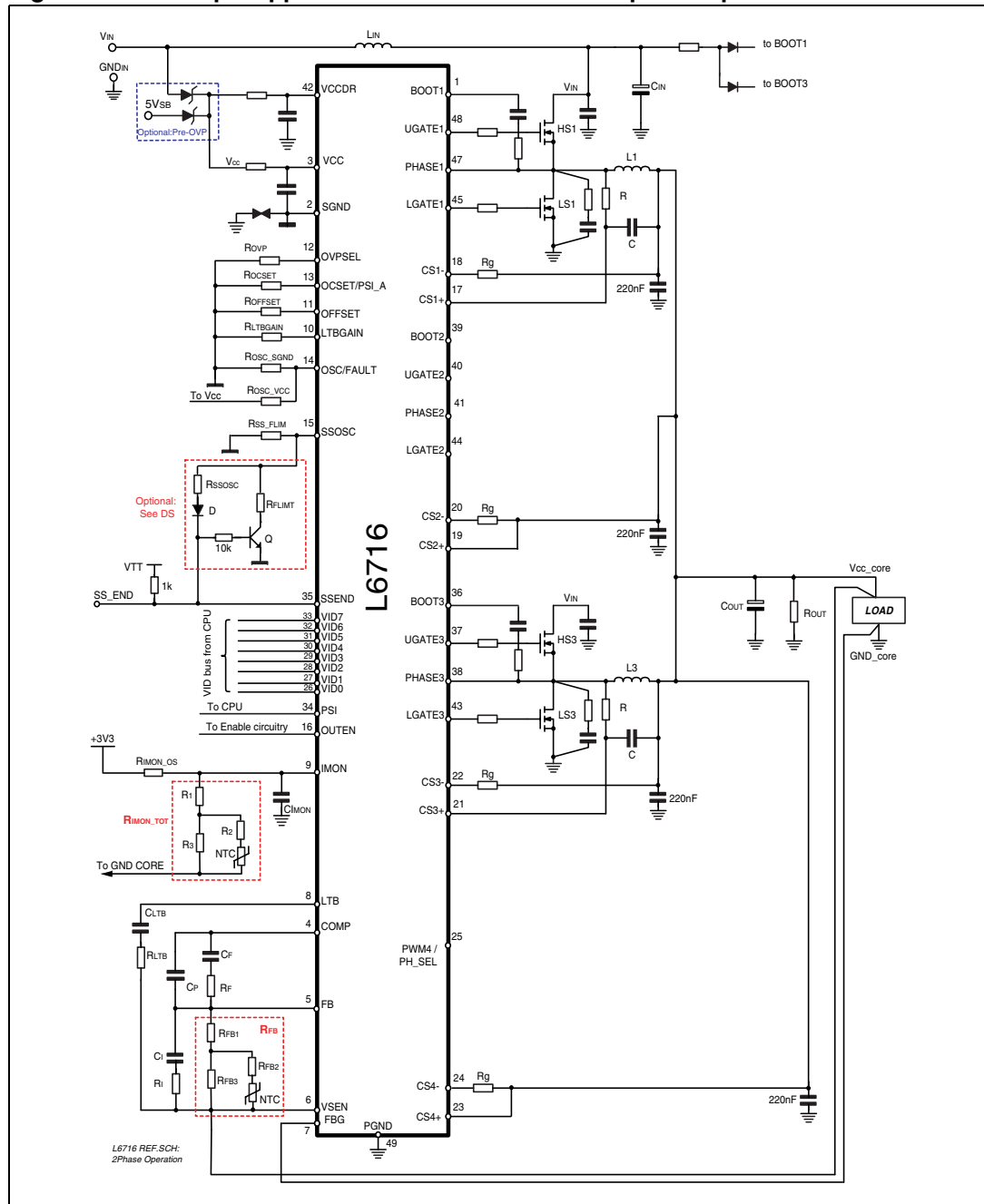

a. Refer to the application note for the reference schematic.

Figure 2. Principle application circuit for VR11.1- 3 phase operation (b)

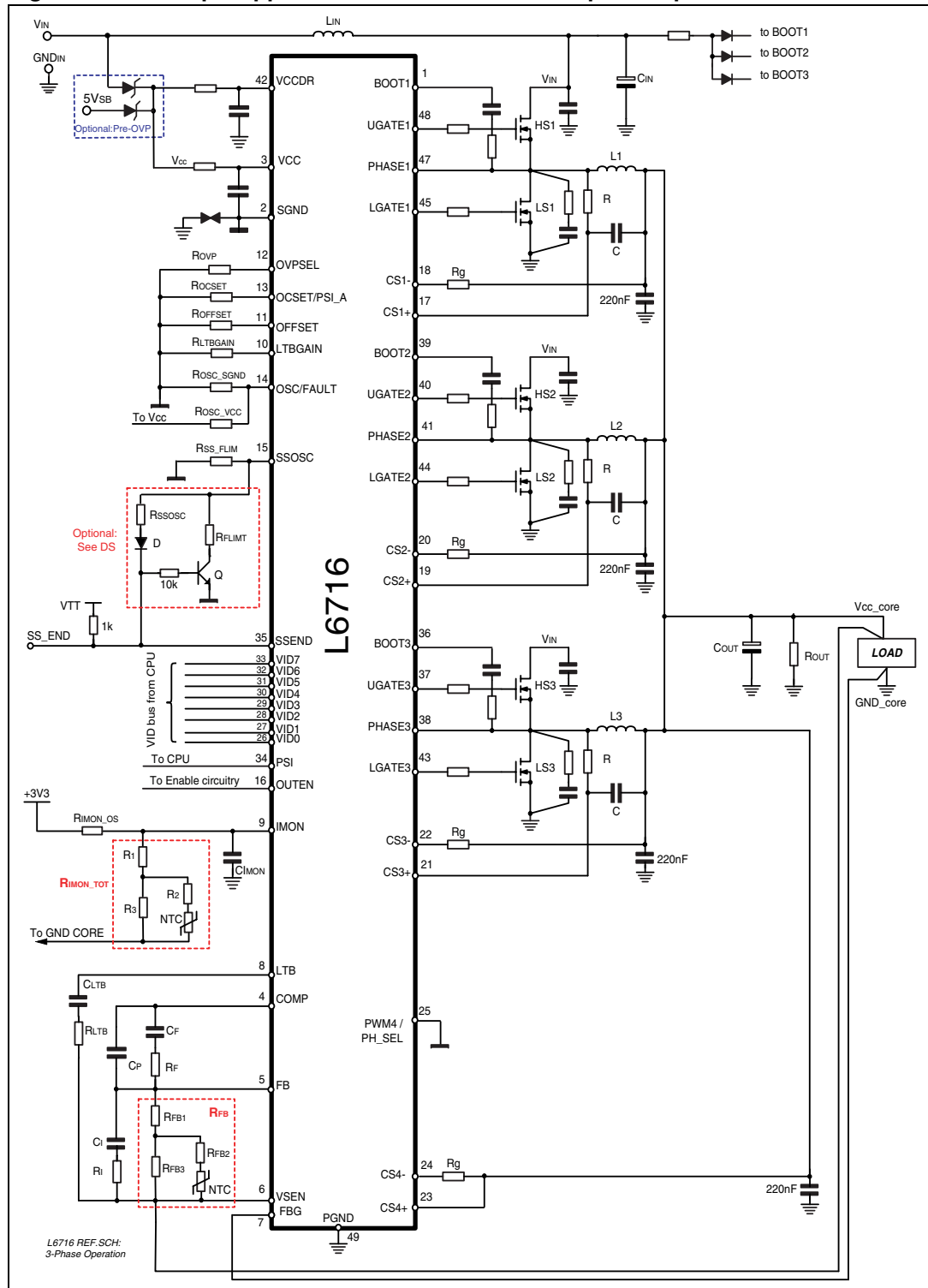

b. Refer to the application note for the reference schematic.

Figure 3. Principle application circuit for VR11.1- 4 phase operation (c)

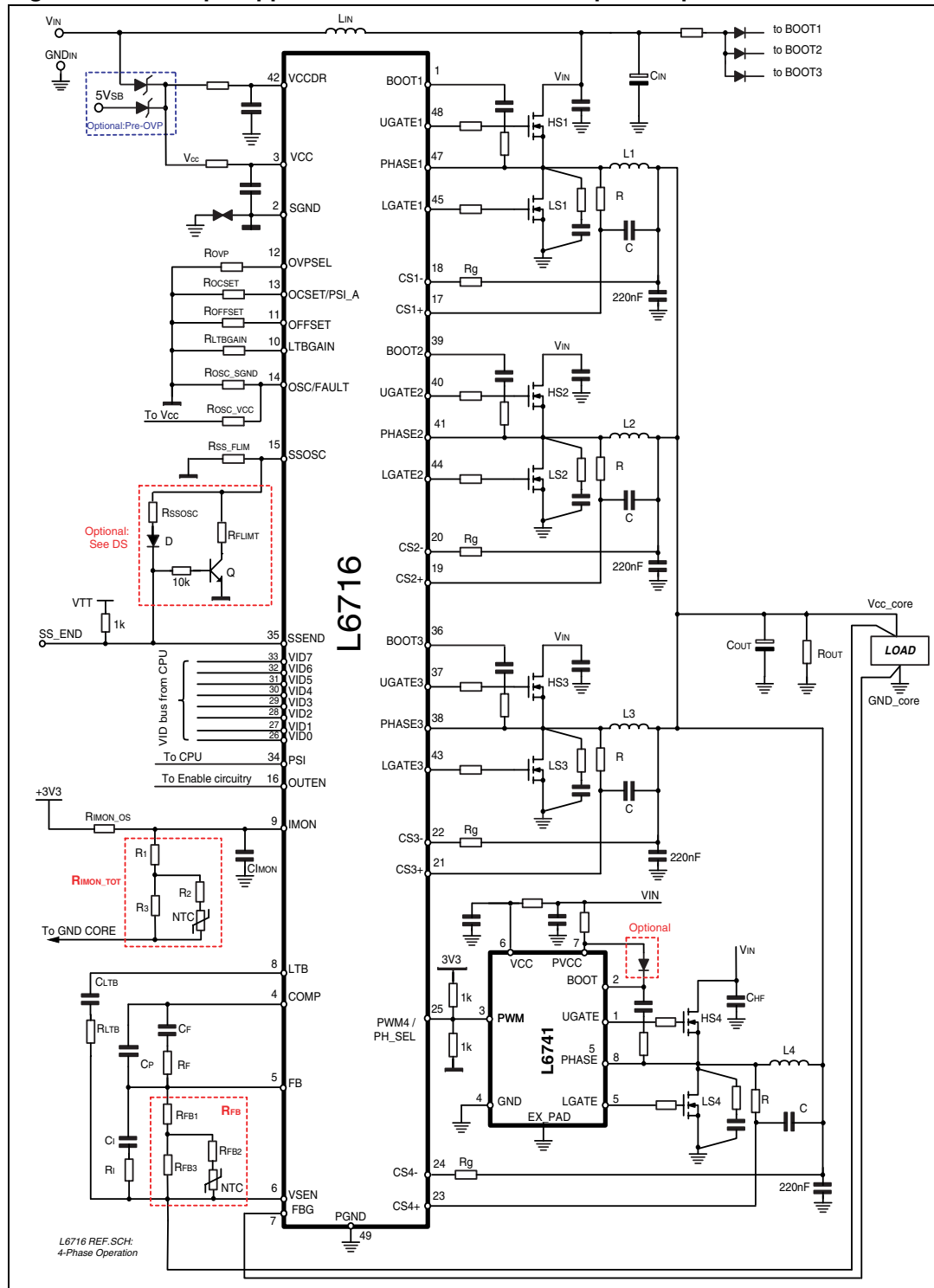

c. Refer to the application note for the reference schematic.

1.2 Block diagram

Figure 4. Block diagram

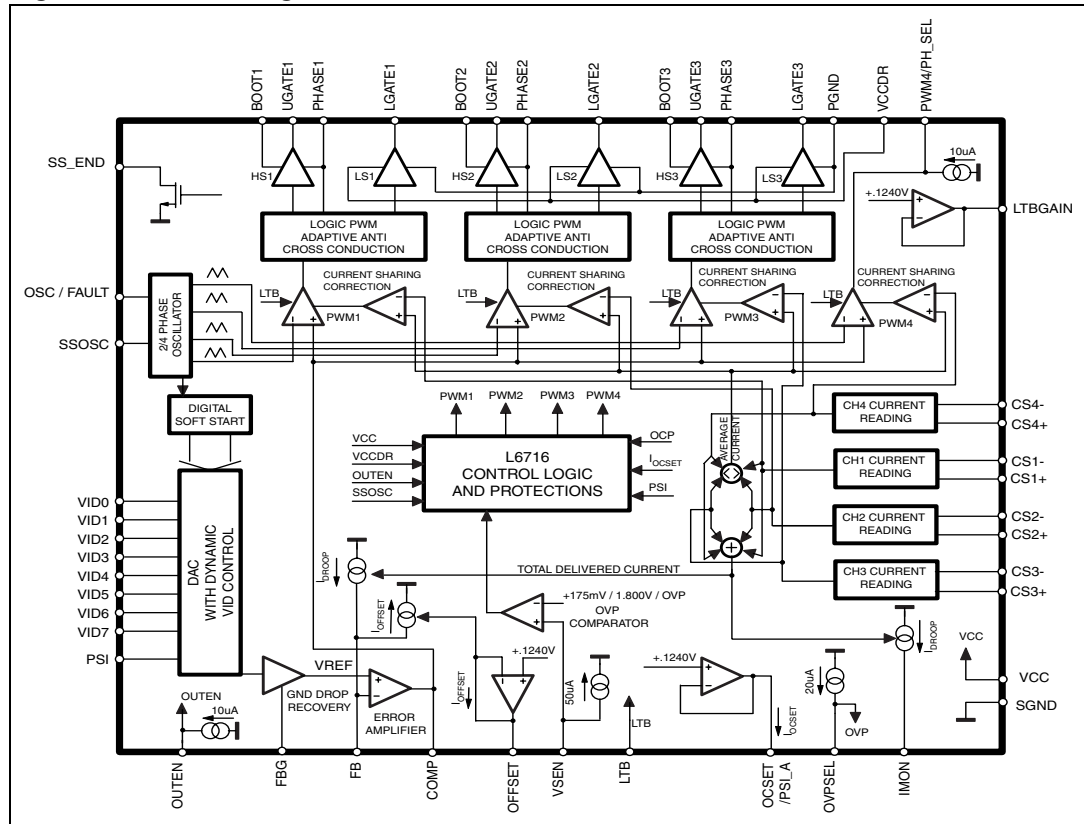

2 Pin description and connection diagram

Figure 5. Pin connection (top view)

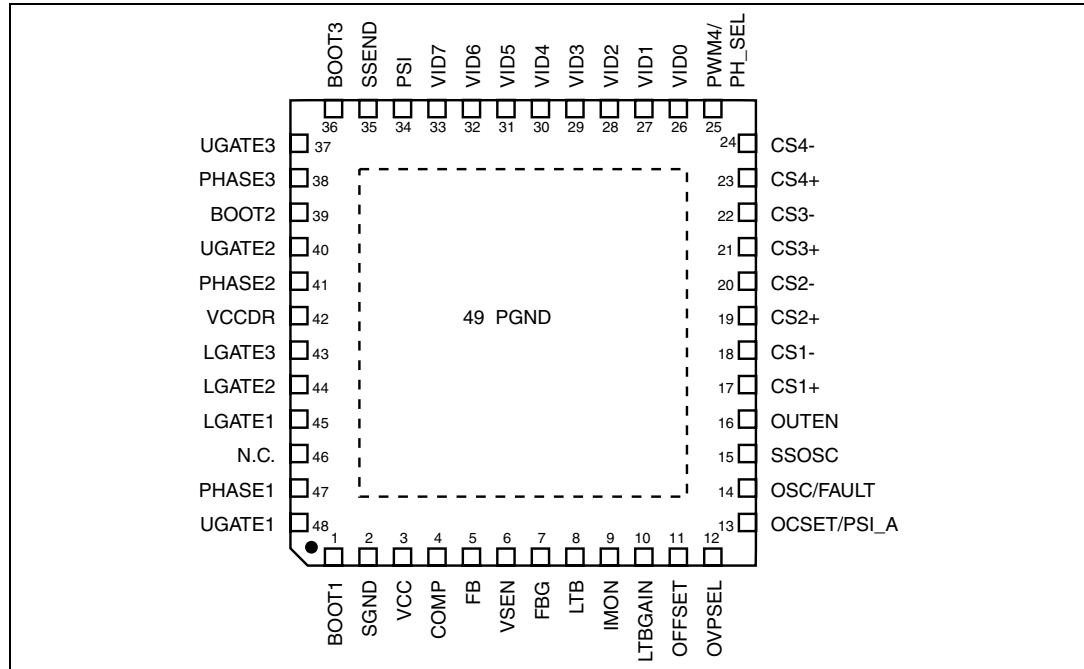

2.1 Pin description

Table 2. Pin description

N°	Name	Description
1	BOOT1	Channel 1 HS driver supply. Connect through a capacitor (100 nF typ.) to PHASE1 and provide necessary bootstrap diode. A small resistor in series to the boot diode helps in reducing boot capacitor overcharge.
2	SGND	All the internal references are referred to this pin. Connect it to the PCB signal ground.
3	VCC	Device supply voltage pin. The operative supply voltage is 12 V ±15%. Filter with at least 1 µF capacitor vs. SGND.
4	COMP	Error amplifier output. Connect with an $R_F - C_F/C_P$ vs. FB pin. The device cannot be disabled by pulling down this pin.
5	FB	Error amplifier inverting input pin. Connect with a resistor R_{FB} vs. VSEN and with an $R_F - C_F/C_P$ vs. COMP pin. A current proportional to the load current is sourced from this pin in order to implement the Droop effect. <i>See "Droop function" Section</i> for details.
6	VSEN	Output voltage monitor, manages OVP/UVF protections and FB disconnection. Connect to the positive side of the load to perform remote sense. <i>See "Layout guidelines" Section</i> for proper layout of this connection.
7	FBG	Connect to the negative side of the load to perform remote sense. <i>See "Layout guidelines" Section</i> for proper layout of this connection.

Table 2. Pin description (continued)

N°	Name	Description
8	LTB	Load transient boost pin. Internally fixed at 2 V, connecting a $R_{LTB} - C_{LTB}$ vs. V_{OUT} allows to enable the load transient boost technology™: as soon as the device detects a transient load it turns on all the PHASEs at the same time. Short to SGND to disable the function. See “Load transient boost technology” Section for details.
9	IMON	Current monitor output pin. A current proportional to the load current is sourced from this pin. Connect through a resistor R_{MON} to FBG to implement a load indicator. Connect the load indicator directly to VR11.1 CPUs. The pin voltage is clamped to 1.1 V max to preserve the CPU from excessive voltages.
10	LTBGAIN	Load transient boost technology™ gain pin. Internally fixed at 1.24 V, connecting a $R_{LTBGAIN}$ resistor vs SGND allows setting the gain of the LTB action. See See “Load transient boost technology” Section for details.
11	OFFSET	Offset programming pin. Internally fixed at 1.240 V, connecting a R_{OFFSET} resistor vs. SGND allows setting a current that is mirrored into FB pin in order to program a positive offset according to the selected R_{FB} . Short to SGND to disable the function. See “Offset (optional)” Section for details.
12	OVPSEL	Overvoltage programming pin. Internally pulled up by 20 μ A (typ) to 3.3 V. Leave floating to use built-in protection thresholds ($OVP_{TH} = VID + 175$ mV typ). Connect to SGND through a R_{OVP} resistor and filter with 100 pF (max) to set the OVP threshold to a fixed voltage according to the R_{OVP} resistor. See “Overvoltage and programmable OVP” Section for details. Connect to SGND to select VR10/VR11 table. In this case the OVP threshold becomes 1.800 V (typ).
13	OCSET/ PSI_A	Overcurrent setting, PSI action pin. Connect to SGND through a R_{OCSET} resistor to set the OCP threshold for each phase. It also allows to select the number of phase when PSI mode is selected. See “Overcurrent protection” Section for details.
14	OSC/ FAULT	Oscillator, FAULT pin. It allows programming the switching frequency F_{SW} of each channel: the equivalent switching frequency at the load side results in being multiplied by the phase number N. Frequency is programmed according to the resistor connected from the pin vs. SGND or VCC with a gain of 9.1 kHz/ μ A (see relevant section for details). Leaving the pin floating programs a switching frequency of 200 kHz per phase. The pin is forced high (3.3 V typ) to signal an OVP/UVP fault: to recover from this condition, cycle VCC or the OUTEN pin. See “Oscillator” Section for details.
15	SSOSC	Soft-start oscillator pin. By connecting a resistor R_{SS} to GND, it allows programming the soft-start time. Soft-Start time T_{SS} will proportionally change with a gain of 25 [μ s / k Ω]. The same slope implemented to reach V_{BOOT} has to be considered also when the reference moves from V_{BOOT} to the programmed VID code. The pin is kept to a fixed 1.240 V. See “Soft-start” Section for details.

Table 2. Pin description (continued)

N°	Name	Description
16	OUTEN	Output enable pin. Internally pulled up by 10 μ A (typ) to 3 V. Forced low, the device stops operations with all MOSFETs OFF: all the protections are disabled except for preliminary overvoltage. Leave floating, the device starts-up implementing soft-start up to the selected VID code. Cycle this pin to recover latch from protections; filter with 1 nF (typ) vs. SGND.
17	CS1+	Channel 1 current sense positive input. Connect through an R-C filter to the phase-side of the channel 1 inductor. <i>See "Layout guidelines" Section</i> for proper layout of this connection.
18	CS1-	Channel 1 current sense negative input. Connect through a Rg resistor to the output-side of the channel 1 inductor. <i>See "Layout guidelines" Section</i> for proper layout of this connection.
19	CS2+	Channel 2 current sense positive input. Connect through an R-C filter to the phase-side of the channel 2 inductor. Short to V _{OUT} when using 2-phase operation. <i>See "Layout guidelines" Section</i> for proper layout of this connection.
20	CS2-	Channel 2 current sense negative input. Connect through a Rg resistor to the output-side of the channel 2 inductor. Still connect to V _{OUT} through Rg resistor when using 2-phase operation. <i>See "Layout guidelines" Section</i> for proper layout of this connection.
21	CS3+	Channel 3 current sense positive input. Connect through an R-C filter to the phase-side of the channel 3 inductor. <i>See "Layout guidelines" Section</i> for proper layout of this connection.
22	CS3-	Channel 3 current sense negative input. Connect through a Rg resistor to the output-side of the channel 3 inductor. <i>See "Layout guidelines" Section</i> for proper layout of this connection.
23	CS4+	Channel 4 current sense positive input. Connect through an R-C filter to the phase-side of the channel 4 inductor. Short to V _{OUT} when using 2-phase or 3-phase operation. <i>See "Layout guidelines" Section</i> for proper layout of this connection.
24	CS4-	Channel 4 current sense negative input. Connect through a Rg resistor to the output-side of the channel 4 inductor. Still connect to V _{OUT} through Rg resistor when using 2-phase or 3-phase operation. <i>See "Layout guidelines" Section</i> for proper layout of this connection.
25	PWM4/ PH_SEL	PWM outputs, phase selection pin. Internally pulled up by 10 μ A to 3.3 V (until the soft-start has not finished), connect to external driver PWM input when 4-phase operation is used. The device is able to manage HiZ status by setting the pin floating. Short to SGND to select 3-phase operation and leave floating to select 2-phase operation.
26 to 33	VID0 to VID7	Voltage identification pins. (not internally pulled up). Connect to SGND to program a '0' or connect to the external pull-up resistor to program a '1'. They allow programming output voltage as specified in <i>Table 7</i> .

Table 2. Pin description (continued)

N°	Name	Description
34	PSI	Power saving indicator pin. Connect to the PSI pin of the CPU to manage low-power state. When asserted (pulled low), the controller will act as programmed on the OCSET/PSI_A.
35	SSEND	Soft-start END signal. Open drain output sets free after ss has finished and pulled low when triggering any protection. Pull up to a voltage lower than 3.3 V, if not used it can be left floating.
36	BOOT3	Channel 3 HS driver supply. Connect through a capacitor (100 nF typ.) to PHASE3 and provide necessary bootstrap diode. A small resistor in series to the boot diode helps in reducing boot capacitor overcharge.
37	UGATE3	Channel 3 HS driver output. It must be connected to the HS3 MOSFET gate. A small series resistors helps in reducing device-dissipated power.
38	PHASE3	Channel 3 HS driver return path. It must be connected to the HS3 MOSFET source and provides return path for the HS driver of channel 3.
39	BOOT2	Channel 2 HS driver supply. Connect through a capacitor (100 nF typ.) to PHASE2 and provide necessary bootstrap diode. A small resistor in series to the boot diode helps in reducing Boot capacitor overcharge. Leave floating when using 2-Phase operation.
40	UGATE2	Channel 2 HS driver output. It must be connected to the HS2 MOSFET gate. A small series resistors helps in reducing device-dissipated power. Leave floating when using 2-Phase operation.
41	PHASE2	Channel 2 HS driver return path. It must be connected to the HS2 MOSFET source and provides return path for the HS driver of channel 2. Leave floating when using 2-phase operation.
42	VCCDR	LS Driver Supply. VCCDR pin voltage has to be the same of VCC pin. Filter with 2 x 1 µF MLCC capacitor vs. PGND.
43	LGATE3	Channel 3 LS driver output. A small series resistor helps in reducing device-dissipated power.
44	LGATE2	Channel 2 LS driver output. A small series resistor helps in reducing device-dissipated power. Leave floating when using 2-phase operation.
45	LGATE1	Channel 1 LS driver output. A small series resistor helps in reducing device-dissipated power.
46	N.C.	Not internally connected.
47	PHASE1	Channel 1 HS driver return path. It must be connected to the HS1 MOSFET source and provides return path for the HS driver of channel 1.

Table 2. Pin description (continued)

N°	Name	Description
48	UGATE1	Channel 1HS driver output. It must be connected to the HS1 MOSFET gate. A small series resistors helps in reducing device-dissipated power.
49	PGND	Power ground pin (LS drivers return path). Connect to power ground plane. Exposed pad connects also the silicon substrate. As a consequence it makes a good thermal contact with the PCB to dissipate the power necessary to drive the external MOSFETs. Connect it to the power ground plane using 5.2 x 5.2 mm square area on the PCB and with sixteen vias (uniformly distributed), to improve electrical and thermal conductivity.

3 Maximum ratings

3.1 Absolute maximum ratings

Table 3. Absolute maximum ratings

Symbol	Parameter	Value	Unit
V_{CC}, V_{CCDR}	To PGND	15	V
V_{BOOTx^-} V_{PHASEx}	Boot voltage	15	V
V_{UGATEx^-} V_{PHASEx}		15	V
	LGATEx to PGND	-0.3 to $V_{CC}+0.3$	V
	All other pins to PGND	-0.3 to 3.6	V
V_{PHASE}	Negative peak voltage to PGND; $T < 400$ ns $V_{CC} = V_{CCDR} = 12$ V	-8	V
	Positive voltage to PGND $V_{CC} = V_{CCDR} = 12$ V	26	V
	Positive peak voltage to PGND; $T < 200$ ns $V_{CC} = V_{CCDR} = 12$ V	30	V
	Maximum withstanding voltage range test condition: CDF-AEC-Q100-002- "human body model" acceptance criteria: "normal performance"	+/- 1750	V

3.2 Thermal data

Table 4. Thermal data

Symbol	Parameter	Value	Unit
R_{thJA}	Thermal resistance junction to ambient (Device soldered on 2s2p PC board)	40	°C / W
T_{MAX}	Maximum junction temperature	150	°C
T_{stg}	Storage temperature range	-40 to 150	°C
T_J	Junction temperature range	-10 to 125	°C
P_{tot}	Max power dissipation at $T_A = 25$ °C	2.5	W

4 Electrical characteristics

4.1 Electrical characteristics

$V_{CC} = 12\text{ V} \pm 15\%$, $T_J = 0\text{ }^\circ\text{C}$ to $70\text{ }^\circ\text{C}$ unless otherwise specified.

Table 5. Electrical characteristics

Symbol	Parameter	Test condition	Min.	Typ.	Max.	Unit
Supply current and power-on						
I_{CC}	VCC supply current	UGATEx and LGATEx open; VCC = VBOOTx = 12 V		22	25	mA
I_{CCDR}	VCCDR supply current	LGATEx = OPEN; VCCDR = 12 V		5	7	mA
I_{BOOTx}	BOOTx supply current	UGATEx = OPEN; PHASEx to PGND; VCC = BOOTx = 12V		1.8	2.7	mA
Power-on						
$UVLO_{VCC}$	VCC turn-ON	VCC rising; VCCDR = VCC		3.7	4.0	V
	VCC turn-OFF	VCC falling; VCCDR = VCC	3.3	3.5		V
$UVLO_{Pre-OVP}$	Pre-OVP turn-ON	VCC rising; VCCDR = VCC		3.7	4.0	V
	Pre-OVP turn-OFF	VCC falling; VCCDR = VCC	3.3	3.5		V
Oscillator and inhibit						
F_{OSC}	Initial accuracy	OSC=OPEN; $T_J = 0$ to $125\text{ }^\circ\text{C}$	180	200	220	kHz
TD_1	SS delay time		1	1.5		ms
TD_2	SS TD_2 time	$R_{SSOSC} = 20\text{ k}\Omega$		500		μs
TD_3	SS TD_3 time		150	250		μs
OUTEN	Output enable	Rising thresholds voltage	0.80	0.85	0.90	V
		Hysteresis		100		mV
	Output pull-up current	OUTEN to SGND		10		μA
ΔV_{osc}	Ramp amplitude			1.5		V
FAULT	Voltage at pin OSC/FAULT	OVP and UVP Active		3.3		V
Reference and DAC						
K_{VID}	Output voltage accuracy	VID = 1.000 V to VID = 1.600 V FB = VOUT; FBG = GNDOUT	-0.5	-	0.5	%
		VID = 0.800 V to VID = 1.000 V FB = VOUT; FBG = GNDOUT	-5	-	+5	mV
		VID = 0.500 V to VID = 0.800 V FB = VOUT; FBG = GNDOUT	-8	-	+8	mV
V_{BOOT}	Boot voltage		1.081			V

Table 5. Electrical characteristics (continued)

Symbol	Parameter	Test condition	Min.	Typ.	Max.	Unit
I_{VID}	VID pull-up current	VIDx to SGND		0		μA
VID_{IH}	VID thresholds	Input low			0.35	V
VID_{IL}		Input high	0.8			V
PSI	PSI thresholds	Input low			0.4	V
		Input high	0.8			
	PSI pull-up current	PSI to SGND		0		μA
Error amplifier						
A_0	EA DC gain			130		dB
SR	EA slew-rate	COMP = 10 pF to SGND		25		V/ μs
Differential current sensing and offset						
I_{CSx+}	Bias current			0		μA
V_{OCSET}	OCSET pin voltage		1.105	1.245	1.385	mV
K_{IDROOP}	Droop current deviation from nominal value	Rg = 1 k Ω ; 1-PHASE, $I_{DROOP} = 25 \mu\text{A}$; 2-PHASE, $I_{DROOP} = 50 \mu\text{A}$; 3-PHASE, $I_{DROOP} = 75 \mu\text{A}$; 4-PHASE, $I_{DROOP} = 100 \mu\text{A}$;	-3	-	+3	μA
$K_{IOFFSET}$	Offset current accuracy	$I_{OFFSET} = 50 \mu\text{A}$ to 250 μA	-5	-	5	%
I_{OFFSET}	OFFSET current range		0		250	μA
V_{OFFSET}	OFFSET pin bias	$I_{OFFSET} = 0$ to 250 μA		1.240		V
Gate drivers						
$t_{RISE UGATE}$	High side rise time	BOOTx-PHASEx = 12 V; C_{UGATEx} to PHASEx = 3.3 nF		20		ns
I_{UGATEx}	High side source current	BOOTx-PHASEx = 12 V		1.5		A
R_{UGATEx}	High side sink resistance	BOOTx-PHASEx = 12 V		2		Ω
$t_{RISE LGATE}$	Low side rise time	VCCDR = 12 V; C_{LGATEx} to PGNDx = 5.6 nF		25		ns
I_{LGATEx}	Low side source current	VCCDR = 12 V		2		A
R_{LGATEx}	Low side sink resistance	VCCDR = 12 V		1		Ω
PWM output						
PWM4	Output high	$I = 1 \text{ mA}$	3			V
	Output low	$I = -1 \text{ mA}$			0.2	V
I_{PWM4}	PWM4 pull-up current	Before SSEND = 1; PWM4 to SGND		10		μA

Table 5. Electrical characteristics (continued)

Symbol	Parameter	Test condition	Min.	Typ.	Max.	Unit
Protections						
OVP	Overvoltage protection (VSEN rising)	Before V _{BOOT}		1.24	1.300	V
		Above VID-19 mV (after TD ₃)	150	175	200	mV
Programmable OVP	I _{OVP} current	OVP = SGND	20	22	24	μA
	Comparator offset voltage	OVP = 1.800 V	-20	0	20	mV
Pre- OVP	Preliminary overvoltage protection	UVLO _{OVP} < VCC < UVLO _{VCC} VCC > UVLO _{VCC} and OUTEN = SGND VSEN rising	1.750	1.800	1.850	V
		Hysteresis		350		mV
UVP	Under voltage threshold	VSEN falling; below VID-19 mV	550	600	650	mV
V _{SSEND}	SS_END voltage low	I = -4 mA			0.4	V

5 Voltage identifications

Table 6. Voltage identification (VID) mapping for intel VR11.1 mode

VID7	VID6	VID5	VID4	VID3	VID2	VID1	VID0
800 mV	400 mV	200 mV	100 mV	50 mV	25 mV	12.5 mV	6.25 mV

Table 7. Voltage identification (VID) for Intel VR11.1 mode

HEX code		Output voltage (1)	HEX code		Output voltage (1)	HEX code		Output voltage (1)	HEX code		Output voltage (1)
0	0	OFF	4	0	1.21250	8	0	0.81250	C	0	0.41250
0	1	OFF	4	1	1.20625	8	1	0.80625	C	1	0.40625
0	2	1.60000	4	2	1.20000	8	2	0.80000	C	2	0.40000
0	3	1.59375	4	3	1.19375	8	3	0.79375	C	3	0.39375
0	4	1.58750	4	4	1.18750	8	4	0.78750	C	4	0.38750
0	5	1.58125	4	5	1.18125	8	5	0.78125	C	5	0.38125
0	6	1.57500	4	6	1.17500	8	6	0.77500	C	6	0.37500
0	7	1.56875	4	7	1.16875	8	7	0.76875	C	7	0.36875
0	8	1.56250	4	8	1.16250	8	8	0.76250	C	8	0.36250
0	9	1.55625	4	9	1.15625	8	9	0.75625	C	9	0.35625
0	A	1.55000	4	A	1.15000	8	A	0.75000	C	A	0.35000
0	B	1.54375	4	B	1.14375	8	B	0.74375	C	B	0.34375
0	C	1.53750	4	C	1.13750	8	C	0.73750	C	C	0.33750
0	D	1.53125	4	D	1.13125	8	D	0.73125	C	D	0.33125
0	E	1.52500	4	E	1.12500	8	E	0.72500	C	E	0.32500
0	F	1.51875	4	F	1.11875	8	F	0.71875	C	F	0.31875
1	0	1.51250	5	0	1.11250	9	0	0.71250	D	0	0.31250
1	1	1.50625	5	1	1.10625	9	1	0.70625	D	1	0.30625
1	2	1.50000	5	2	1.10000	9	2	0.70000	D	2	0.30000
1	3	1.49375	5	3	1.09375	9	3	0.69375	D	3	0.29375
1	4	1.48750	5	4	1.08750	9	4	0.68750	D	4	0.28750
1	5	1.48125	5	5	1.08125	9	5	0.68125	D	5	0.28125
1	6	1.47500	5	6	1.07500	9	6	0.67500	D	6	0.27500
1	7	1.46875	5	7	1.06875	9	7	0.66875	D	7	0.26875
1	8	1.46250	5	8	1.06250	9	8	0.66250	D	8	0.26250
1	9	1.45625	5	9	1.05625	9	9	0.65625	D	9	0.25625

Table 7. Voltage identification (VID) for Intel VR11.1 mode (continued)

HEX code		Output voltage (1)	HEX code		Output voltage (1)	HEX code		Output voltage (1)	HEX code		Output voltage (1)
1	A	1.45000	5	A	1.05000	9	A	0.65000	D	A	0.25000
1	B	1.44375	5	B	1.04375	9	B	0.64375	D	B	0.24375
1	C	1.43750	5	C	1.03750	9	C	0.63750	D	C	0.23750
1	D	1.43125	5	D	1.03125	9	D	0.63125	D	D	0.23125
1	E	1.42500	5	E	1.02500	9	E	0.62500	D	E	0.22500
1	F	1.41875	5	F	1.01875	9	F	0.61875	D	F	0.21875
2	0	1.41250	6	0	1.01250	A	0	0.61250	E	0	0.21250
2	1	1.40625	6	1	1.00625	A	1	0.60625	E	1	0.20625
2	2	1.40000	6	2	1.00000	A	2	0.60000	E	2	0.20000
2	3	1.39375	6	3	0.99375	A	3	0.59375	E	3	0.19375
2	4	1.38750	6	4	0.98750	A	4	0.58750	E	4	0.18750
2	5	1.38125	6	5	0.98125	A	5	0.58125	E	5	0.18125
2	6	1.37500	6	6	0.97500	A	6	0.57500	E	6	0.17500
2	7	1.36875	6	7	0.96875	A	7	0.56875	E	7	0.16875
2	8	1.36250	6	8	0.96250	A	8	0.56250	E	8	0.16250
2	9	1.35625	6	9	0.95625	A	9	0.55625	E	9	0.15625
2	A	1.35000	6	A	0.95000	A	A	0.55000	E	A	0.15000
2	B	1.34375	6	B	0.94375	A	B	0.54375	E	B	0.14375
2	C	1.33750	6	C	0.93750	A	C	0.53750	E	C	0.13750
2	D	1.33125	6	D	0.93125	A	D	0.53125	E	D	0.13125
2	E	1.32500	6	E	0.92500	A	E	0.52500	E	E	0.12500
2	F	1.31875	6	F	0.91875	A	F	0.51875	E	F	0.11875
3	0	1.31250	7	0	0.91250	B	0	0.51250	F	0	0.11250
3	1	1.30625	7	1	0.90625	B	1	0.50625	F	1	0.10625
3	2	1.30000	7	2	0.90000	B	2	0.50000	F	2	0.10000
3	3	1.29375	7	3	0.89375	B	3	0.49375	F	3	0.09375
3	4	1.28750	7	4	0.88750	B	4	0.48750	F	4	0.08750
3	5	1.28125	7	5	0.88125	B	5	0.48125	F	5	0.08125
3	6	1.27500	7	6	0.87500	B	6	0.47500	F	6	0.07500
3	7	1.26875	7	7	0.86875	B	7	0.46875	F	7	0.06875
3	8	1.26250	7	8	0.86250	B	8	0.46250	F	8	0.06250
3	9	1.25625	7	9	0.85625	B	9	0.45625	F	9	0.05625
3	A	1.25000	7	A	0.85000	B	A	0.45000	F	A	0.05000
3	B	1.24375	7	B	0.84375	B	B	0.44375	F	B	0.04375

Table 7. Voltage identification (VID) for Intel VR11.1 mode (continued)

HEX code		Output voltage (1)	HEX code		Output voltage (1)	HEX code		Output voltage (1)	HEX code		Output voltage (1)
3	C	1.23750	7	C	0.83750	B	C	0.43750	F	C	0.03750
3	D	1.23125	7	D	0.83125	B	D	0.43125	F	D	0.03125
3	E	1.22500	7	E	0.82500	B	E	0.42500	F	E	OFF
3	F	1.21875	7	F	0.81875	B	F	0.41875	F	F	OFF

1. According to INTEL specs, the device automatically regulates output voltage 19 mV lower to avoid any external offset to modify the built-in 0.5% accuracy improving TOB performances. Output regulated voltage is than what extracted from the table lowered by 19 mV.

6 Device description

L6716 is two-to-four phase PWM controller with three embedded high current drivers providing complete control logic and protections for a high performance step-down DC-DC voltage regulator optimized for advanced microprocessor power supply. Multi phase buck is the simplest and most cost-effective topology employable to satisfy the increasing current demand of newer microprocessors and modern high current VRM modules. It allows distributing equally load and power between the phases using smaller, cheaper and most common external power MOSFETs and inductors. Moreover, thanks to the equal phase shift between each phase, the input and output capacitor count results in being reduced. Phase interleaving causes in fact input rms current and output ripple voltage reduction.

L6716 is a dual-edge asynchronous PWM controller featuring load transient boost LTB Technology™: the device turns on simultaneously all the phases as soon as a load transient is detected allowing to minimize system cost by providing the fastest response to load transition. Load transition is detected (through LTB pin) measuring the derivate dV/dt of the output voltage and the dV/dt can be easily programmed extending the system design flexibility. Moreover, load transient boost (LTB) Technology™ gain can be easily modified in order to keep under control the output voltage ring back.

LTB Technology™ can be disabled and in this condition the device works as a dual-edge asynchronous PWM.

The controller allows to implement a scalable design: a three phase design can be easily downgraded to two phase and upgraded to four phase (using an external driver). The same design can be used for more than one project saving development and debug time.

L6716 permits easy system design by allowing current reading across inductor in fully differential mode. Also a sense resistor in series to the inductor can be considered to improve reading precision. The current information read corrects the PWM output in order to equalize the average current carried by each phase limiting the error in the static and dynamic conditions.

The controller allows compatibility with both Intel VR11.0 and VR11.1 processors specifications, also performing D-VID transitions accordingly.

The device is VR11.1 compatible implementing IMON signal and managing the PSI# signal to enhance the system performances at low current in low-power states.

Low-side-less start-up allows soft-start over pre-biased output avoiding dangerous current return through the main inductors as well as negative spike at the load side.

L6716 provides a programmable overvoltage protection to protect the load from dangerous over stress, latching immediately by turning ON the lower driver and driving high the OSC/FAULT pin. Furthermore, preliminary OVP protection also allows the device to protect load from dangerous OVP when VCC is not above the UVLO threshold or OUTEN is low. The overcurrent protection is for each phase and externally adjustable through a single resistor. The device keeps constant the peak of the inductor current ripple working in constant current mode until the latched UVP.

A compact 7x7 mm body VFQFPN-48 package with exposed thermal pad allows dissipating the power to drive the external MOSFET through the system board.

7 DAC and Phase number selection

L6716 embeds VRD11.x DAC (see [Table 7](#)) that allows to regulate the output voltage with a tolerance of $\pm 0.5\%$ recovering from offsets and manufacturing variations.

The device automatically introduces a -19 mV (both VRD11.x and VR10) offset to the regulated voltage in order to avoid any external offset circuitry to worsen the guaranteed accuracy and, as a consequence, the calculated system TOB.

Output voltage is programmed through the VID pins: they are inputs of an internal DAC that is realized by means of a series of resistors providing a partition of the internal voltage reference. The VID code drives a multiplexer that selects a voltage on a precise point of the divider. The DAC output is delivered to an amplifier obtaining the voltage reference (i.e. the set-point of the error amplifier, V_{REF}).

L6716 implements a flexible 2 to 4 interleaved-phase converter. The device allows to select the phase number operation simply using the PWM4/PHASE_SEL pin, as shown in the following table.

Table 8. Number of phases setting

PWM4 / PH_SEL pin	Number of phases	Phases used
Floating	2-PHASE	Phase1, Phase3
Short to SGND	3-PHASE	Phase1, Phase2, Phase3
Connect to PWM driver input	4-PHASE	Phase1, Phase2, Phase3, Phase4

Note: PWM4 pin is internally pulled up by 10 μ A to 3.3 V, until soft-start is not finished.

For the disabled phase(s), the current reading pins need to be properly connected to avoid errors in current-sharing and voltage-positioning: CSx+ needs to be connected to the regulated output voltage while CSx- needs to be connected to V_{OUT} through the same R_G resistor used for the other phases.

Note: To select VR10/VR11 table, short to SGND the OVP pin. In this case the PSI pin becomes the VIDSEL pin (to select VR10 and VR11 table, in according to the VR11 specification).

8 Power dissipation

L6716 embeds three high current MOSFET drivers for both high side and low side MOSFETs: it is then important to consider the power the device is going to dissipate in driving them in order to avoid overcoming the maximum junction operative temperature.

Exposed pad (PGND pin) needs to be soldered to the PCB power ground plane through several VIAs in order to facilitate the heat dissipation.

Two main terms contribute in the device power dissipation: bias power and drivers' power. The first one (P_{DC}) depends on the static consumption of the device through the supply pins and it is simply quantifiable as follow (assuming to supply HS and LS drivers with the same VCC of the device):

$$P_{DC} = V_{CC} \cdot (I_{CC} + I_{CCDR} + N_D \cdot I_{BOOTX})$$

where N_D is the number of internal drivers used.

Drivers' power is the power needed by the driver to continuously switch on and off the external MOSFETs; it is a function of the switching frequency and total gate charge of the selected MOSFETs. It can be quantified considering that the total power P_{SW} dissipated to switch the MOSFETs (easy calculable) is dissipated by three main factors: external gate resistance (when present), intrinsic MOSFET resistance and intrinsic driver resistance. This last term is the important one to be determined to calculate the device power dissipation.

The total power dissipated to switch the MOSFETs results:

$$P_{SW} = N_D \cdot F_{SW} \cdot (Q_{GHS} \cdot V_{BOOT} + Q_{GLS} \cdot V_{CCDR})$$

External gate resistors helps the device to dissipate the switching power since the same power P_{SW} will be shared between the internal driver impedance and the external resistor resulting in a general cooling of the device. When driving multiple MOSFETs in parallel, it is suggested to use one gate resistor for each MOSFET.

Figure 6. L6716 dissipated power (quiescent + switching)

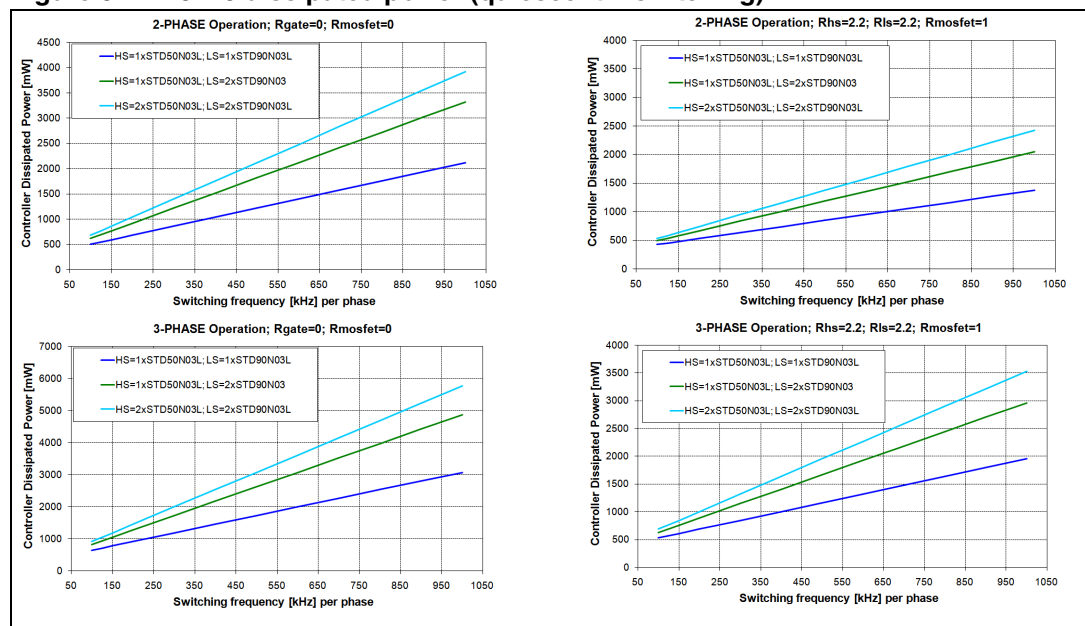

9 Current reading and current sharing loop

L6716 embeds a flexible, fully-differential current sense circuitry that is able to read across inductor parasitic resistance or across a sense resistor placed in series to the inductor element. The fully-differential current reading rejects noise and allows placing sensing element in different locations without affecting the measurement's accuracy.

Reading current across the inductor DCR, the current flowing through each phase is read using the voltage drop across the output inductor or across a sense resistor in its series and internally converted into a current. The trans-conductance ratio is issued by the external resistor R_g placed outside the chip between CSx- pin toward the reading points.

The current sense circuit always tracks the current information, no bias current is sourced from the CSx+ pin: this pin is used as a reference keeping the CSx- pin to this voltage. To correctly reproduce the inductor current an R-C filtering network must be introduced in parallel to the sensing element.

The current that flows from the CSx- pin is then given by the following equation (see [Figure 7](#)):

$$I_{CSx-} = \frac{DCR}{R_g} \cdot \frac{1 + s \cdot L / (DCR)}{1 + s \cdot R \cdot C} \cdot I_{PHASEx}$$

Where I_{PHASEx} is the current carried by the relative phase.

Figure 7. Current reading connections

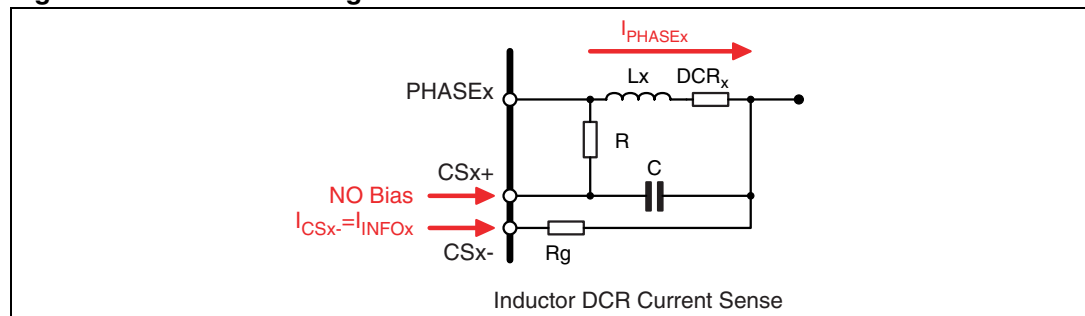

Considering now to match the time constant between the inductor and the R-C filter applied (Time constant mismatches cause the introduction of poles into the current reading network causing instability. In addition, it is also important for the load transient response and to let the system show resistive equivalent output impedance), it results:

$$\frac{L}{DCR} = R \cdot C \Rightarrow I_{CSx-} = \frac{DCR}{R_g} \cdot I_{PHASEx} = I_{INFOX} \Rightarrow I_{INFOX} = \frac{DCR}{R_g} \cdot I_{PHASEx}$$

Where I_{INFOX} is the current information reproduced internally.

The R_g trans-conductance resistor has to be selected using the following formula, in order to guarantee the correct functionality of internal current reading circuitry:

$$R_g = \frac{DCR^{MAX}}{20\mu A} \cdot \frac{I_{OUT}^{MAX}}{N}$$

Where I_{OUT}^{MAX} is the maximum output current, DCR^{MAX} the maximum inductor DCR and N number of phases.

For the disabled phase(s), the current reading pins need to be properly connected to avoid errors in current-sharing and voltage-positioning: CSx+ needs to be connected to the regulated output voltage while CSx- needs to be connected to V_{OUT} through the same R_G resistor used for the other phases, as shown in figure [Figure 9](#).

Figure 8. Current reading connections for the disabled phase

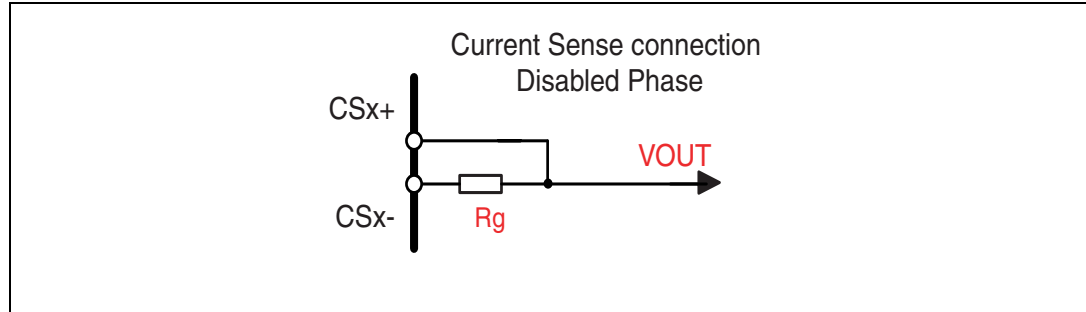

Current sharing control loop reported in [Figure 9](#): it considers a current I_{INFOx} proportional to the current delivered by each phase and the average current $I_{AVG} = \sum I_{INFOx} / N$. The error between the read current I_{INFOx} and the reference I_{AVG} is then converted into a voltage that with a proper gain is used to adjust the duty cycle whose dominant value is set by the voltage error amplifier in order to equalize the current carried by each phase. Details about connections are shown in [Figure 9](#).

Figure 9. Current sharing loop

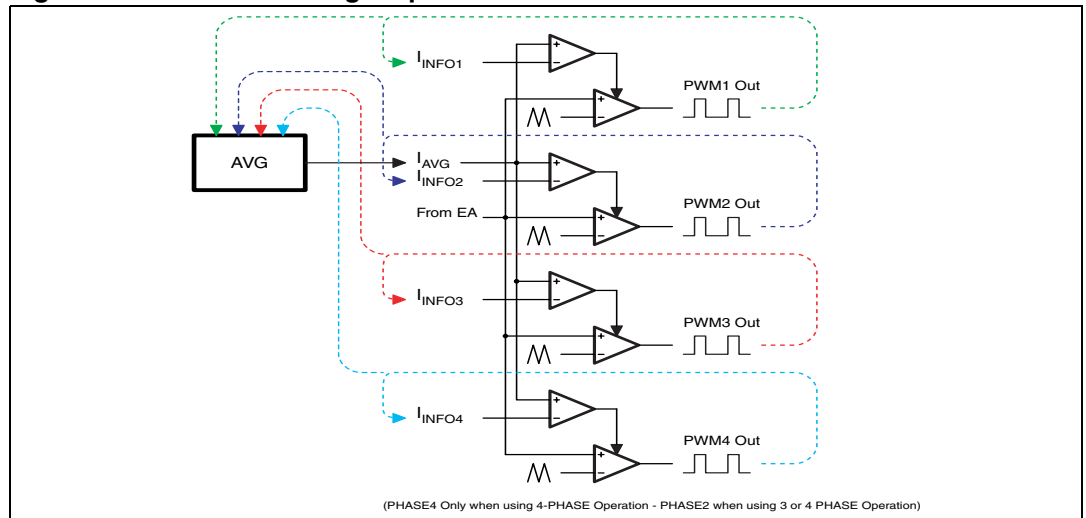

10 Differential remote voltage sensing

The output voltage is sensed in fully-differential mode between the FB and FBG pin.

The FB pin has to be connected through a resistor to the regulation point while the FBG pin has to be connected directly to the remote sense ground point.

In this way, the output voltage programmed is regulated between the remote sense point compensating motherboard or connector losses.

Keeping the FB and FBG traces parallel and guarded by a power plane results in common mode coupling for any picked-up noise.

Figure 10. Differential remote voltage sensing connections

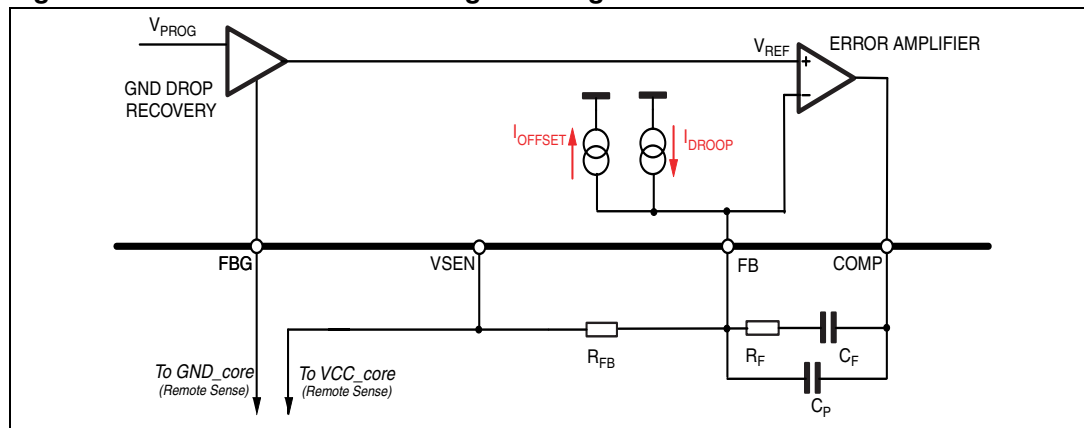

11 Voltage positioning

Output voltage positioning is performed by selecting the internal reference value through VID pins and by programming the droop function and offset to the reference (see [Figure 11](#)). The currents sourced/sunk from FB pin cause the output voltage to vary according to the external R_{FB} .

The output voltage is then driven by the following relationship:

$$V_{OUT}(I_{OUT}) = V_{PROG} - R_{FB} \cdot [I_{DROOP}(I_{OUT}) - I_{OFFSET}]$$

where:

$$V_{PROG} = VID - 19\text{mV}$$

$$I_{DROOP}(I_{OUT}) = \frac{DCR}{R_g} \cdot I_{OUT}$$

$$I_{OFFSET} = \frac{1.240\text{V}}{R_{OFFSET}}$$

OFFSET function can be disabled shorting to SGND the OFFSET pin.

Figure 11. Voltage positioning (left) and droop function (right)

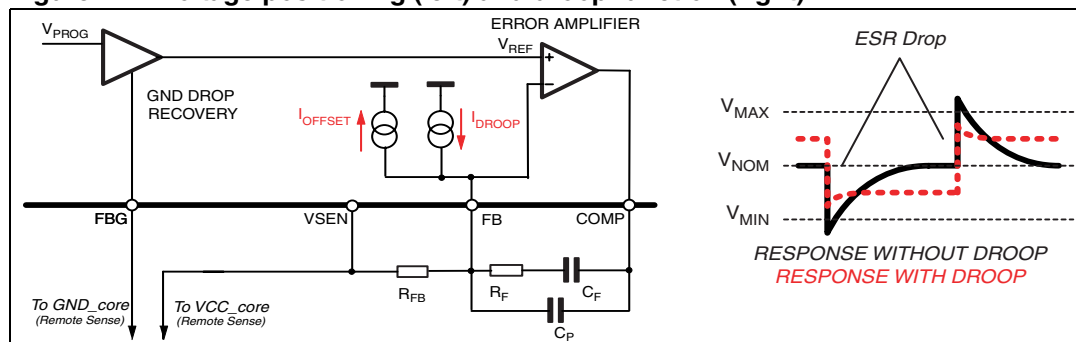

11.1 Offset (optional)

The OFFSET pin allows programming a positive offset (V_{OS}) for the output voltage by connecting a resistor R_{OFFSET} vs. SGND as shown in [Figure 12](#); this offset has to be considered in addition to the one already introduced during the production stage ($V_{PROG}=VID-19\text{ mV}$).

OFFSET function can be disabled shorting to SGND the OFFSET pin.

The OFFSET pin is internally fixed at 1.240 V (See [Table 5](#)) a current is programmed by connecting the resistor R_{OFFSET} between the pin and SGND: this current is mirrored and then properly sunk from the FB pin as shown in [Figure 12](#). Output voltage is then programmed as follow:

$$V_{OUT}(I_{OUT}) = V_{PROG} - R_{FB} \cdot \left[I_{DROOP}(I_{OUT}) - \frac{1.240\text{V}}{R_{OFFSET}} \right]$$

where:

$$V_{OS} = R_{FB} \cdot \frac{1.240V}{R_{OFFSET}}$$

Offset resistor can be designed by considering the following relationship (RFB is fixed by the Droop effect):

$$R_{OFFSET} = R_{FB} \cdot \frac{1.240V}{V_{OS}}$$

Offset automatically given by the DAC selection differs from the offset implemented through the OFFSET pin: the built-in feature is trimmed in production and assures $\pm 0.5\%$ error over load and line variations.

Figure 12. Voltage positioning with positive offset

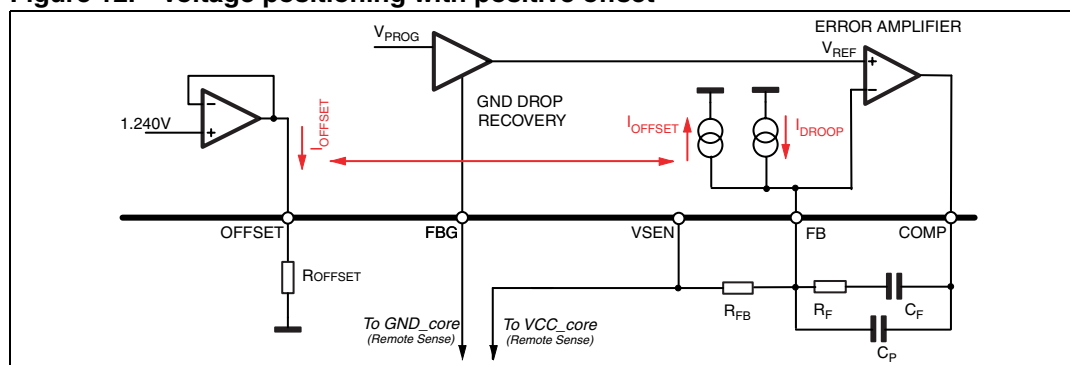

11.2 Droop function

This method “recovers” part of the drop due to the output capacitor ESR in the load transient, introducing a dependence of the output voltage on the load current: a static error proportional to the output current causes the output voltage to vary according to the sensed current.

As shown in [Figure 11](#), the ESR drop is present in any case, but using the droop function the total deviation of the output voltage is minimized. Moreover, more and more high-performance CPUs require precise load-line regulation to perform in the proper way. DROOP function is not then required only to optimize the output filter, but also becomes a requirement of the load.

The device forces a current I_{DROOP} proportional to the load current, into the feedback R_{FB} resistor implementing the load regulation dependence. Since I_{DROOP} depends on the current information about the N phases, the output characteristic vs. load current is then given by (neglecting the OFFSET voltage term):

$$V_{OUT} = V_{PROG} - R_{FB} \cdot I_{DROOP} = V_{REF} - R_{FB} \cdot \frac{DCR}{R_g} \cdot I_{OUT} = V_{PROG} - R_{DROOP} \cdot I_{OUT}$$

Where DCR is the inductor parasitic resistance (or sense resistor when used) and I_{OUT} is the output current of the system. The whole power supply can be then represented by a “real” voltage generator with an equivalent output resistance R_{DROOP} and a voltage value of V_{PROG} . R_{FB} resistor can be also designed according to the R_{DROOP} specifications as follow:

$$R_{FB} = R_{DROOP} \cdot \frac{R_g}{DCR}$$

12 Droop thermal compensation

Current sense element (DCR inductor) has a non-negligible temperature variation. As a consequence, the sensed current is subjected to a measurement error that causes the regulated output voltage to vary accordingly (when droop function is implemented).

To recover from this temperature related error, NTC resistor can be added into feedback compensation network, as shown in [Figure 13](#).

The output voltage is then driven by the following relationship (neglecting the OFFSET voltage term):

$$V_{OUT} = V_{PROG} - (R_{FB} \cdot I_{DROOP})$$

where R_{FB} is the equivalent feedback resistor and it depends on the temperature through NTC resistor.

Considering the relationships between I_{DROOP} and the I_{OUT} , the output voltage results:

$$V_{OUT}[(T, I_{OUT})] = V_{PROG} - \left(R_{FB}[T] \cdot \frac{DCR[T]}{R_g} \cdot I_{OUT} \right)$$

where T is the temperature.

If the inductor temperature increases the DCR inductor increases and NTC resistor decreases. As a consequence the equivalent R_{FB} resistor decreases keeping constant the output voltage respect to temperature variation.

NTC resistor must be placed as close as possible to the sense elements (phase inductor).

Figure 13. NTC connections for DC load line thermal compensation

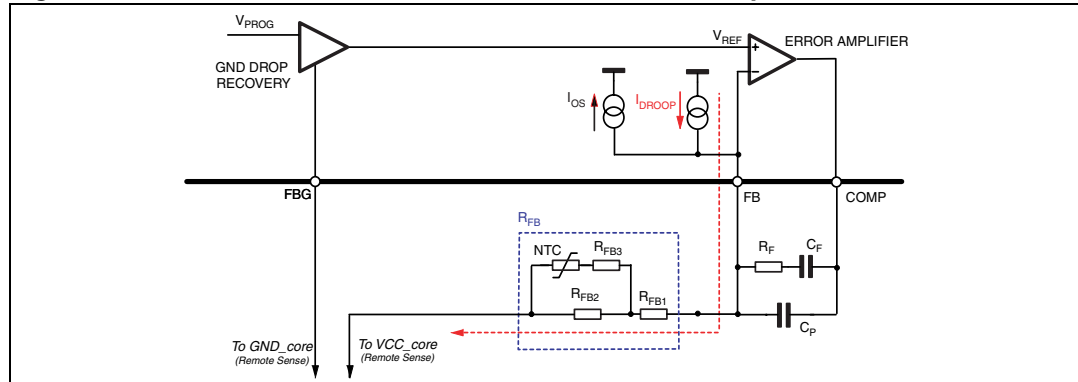

13 Output current monitoring (IMON)

The device sources from IMON pin a current proportional to the load current (the sourced current is a copy of Droop current).

Connect IMON pin through a R_{IMON} resistor to remote ground (GND core) to implement a load indicator, as shown in [Figure 14](#).

As Intel VR11.1 specification required, on the IMON voltage as to be added a small positive offset to avoid under-estimation of the output load (due to elements accuracy).

The voltage across IMON pin is given by the following formula:

$$V_{MONITORING} = \frac{R_{IMON} \cdot R_{OS}}{R_{IMON} + R_{OS}} \cdot I_{DROOP} + V_{REF} \cdot \frac{R_{IMON}}{R_{IMON} + R_{OS}}$$

where:

$$I_{DROOP} = \frac{DCR}{R_g} \cdot I_{OUT}$$

The IMON pin voltage is clamped to 1.100 V max to preserve the CPU from excessive voltages as Intel VR11.1 specification required.

Figure 14. Output monitoring connection (left) and thermal compensation (right)

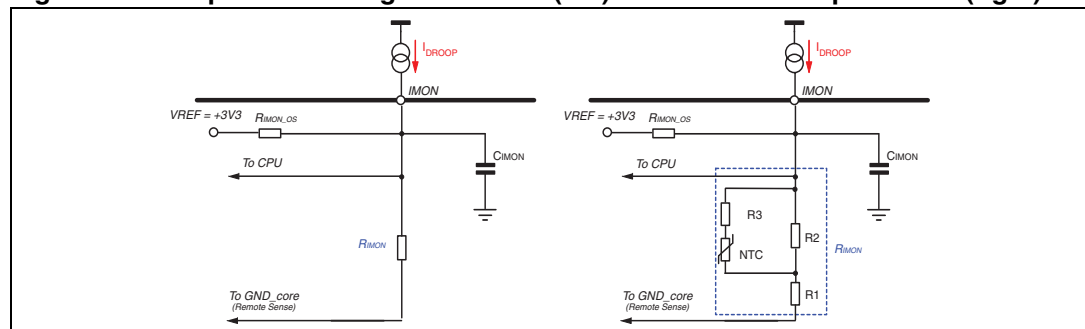

Current sense element (DCR inductor) has a non-negligible temperature variation. As a consequence, the sensed current is subjected to a measurement error that causes the monitoring voltage to vary accordingly.

To recover from this temperature related error, NTC resistor can be added into monitoring network, as shown in [Figure 14](#).

The monitoring voltage is then driven by the following relationship (neglecting the offset term for simplicity):

$$V_{MONITORING} = \frac{R_{IMON} \cdot R_{OS}}{R_{IMON} + R_{OS}} \cdot I_{DROOP} = \frac{R_{IMON} \cdot R_{OS}}{R_{IMON} + R_{OS}} \cdot \frac{DCR}{R_g} \cdot I_{OUT}$$

where now the R_{IMON} is the equivalent monitoring resistor and it depends on the temperature through NTC resistor.

Considering the relationships between I_{DROOP} and the I_{OUT} , the voltage results:

$$V_{MONITORING}[(T, I_{OUT})] = \frac{R_{IMON}[T] \cdot R_{OS}}{R_{IMON}[T] + R_{OS}} \cdot \frac{DCR[T]}{R_g} \cdot I_{OUT}$$

where T is the temperature.

If the inductor temperature increases the DCR inductor increases and NTC resistor decreases. As a consequence the equivalent R_{IMON} resistor decreases keeping constant the monitoring voltage respect to temperature variation. NTC resistor must be placed as close as possible to the sense elements (phase inductor).

14 Load transient boost technology

LTB Technology™ further enhances the performances of dual-edge asynchronous systems by reducing the system latencies and immediately turning ON all the phases to provide the correct amount of energy to the load.

By properly designing the LTB network, as well as the LTB gain, the undershoot and the ring-back can be minimized also optimizing the output capacitors count.

LTB Technology™ monitors the output voltage through a dedicated pin (see [Figure 16](#)) detecting load-transients with selected dV/dt , it cancels the interleaved phase-shift, turning-on simultaneously all phases.

It then implements a parallel independent loop that (bypassing error amplifier (E/A) latencies) reacts to load-transients in very short time ($\ll 200$ ns).

LTB Technology™ control loop is reported in [Figure 15](#).

Figure 15. LTB Technology™ control loop

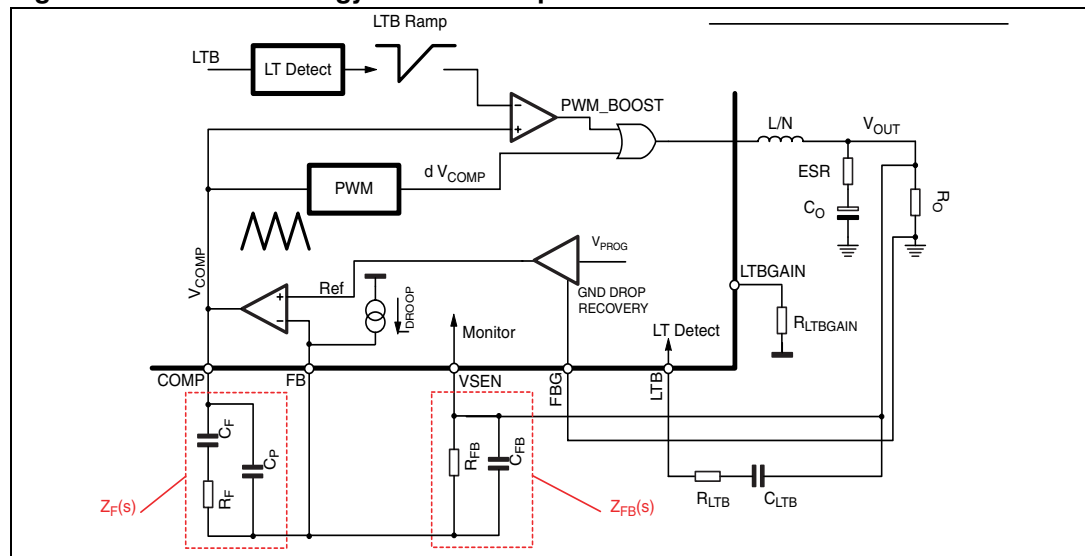

The LTB detector is able to detect output load transients by coupling the output voltage through an $R_{LTB} - C_{LTB}$ network. After detecting a load transient, the LTB ramp is reset and then compared with the COMP pin level. The resulting duty-cycle programmed is then OR-ed with the PWMx signal of each phase by-passing the main control loop. All the phases will then be turned-on together and the EA latencies results bypassed as well.

Short LTB pin to SGND to disable the LTB Technology™: in this condition the device works as a dual-edge asynchronous PWM controller.

Sensitivity of the load transient detector and the gain of the LTB ramp can be programmed in order to control precisely both the undershoot and the ring-back.

- Detector design. $R_{LTB} - C_{LTB}$ is design according to the output voltage deviation dV_{OUT} which is desired the controller to be sensitive as follow:

$$R_{LTB} = \frac{dV_{OUT}}{25\mu A} \quad C_{LTB} = \frac{1}{2\pi \cdot R_{LTB} \cdot N \cdot F_{SW}}$$

- Gain design. Through the LTBGAIN pin it is possible to modify the slope of the LTB Ramp in order to modulate the entity of the LTB response once the LT has been detected. In fact, the response depends on the board design and its parasites requiring different actions from the controller.

Connect $R_{LTBGAIN}$ to SGND using the following relationship in order to select the default value (slope of the LTB ramp equal to 1/2 of the OSC ramp slope).

$$R_{LTBGAIN}[k\Omega] = \frac{2 \cdot 1240 \cdot 10^3}{\left[20 + \left(\frac{F_{sw}[kHz] - 200}{10}\right)\right]}$$

Where F_{SW} is the selected switching frequency (in kHz).

LTB Technology™ design tips.

- Decreases R_{LTB} to increase the system sensitivity making the system sensitive to smaller dV_{OUT} .
- Increase C_{LTB} to increase the system sensitivity making the system sensitive to higher dV/dt .
- Decrease $R_{LTBGAIN}$ to decrease the width of the LTB pulse reducing the system ring-back or vice versa.

Figure 16. LTB connections (left) and waveform (right)

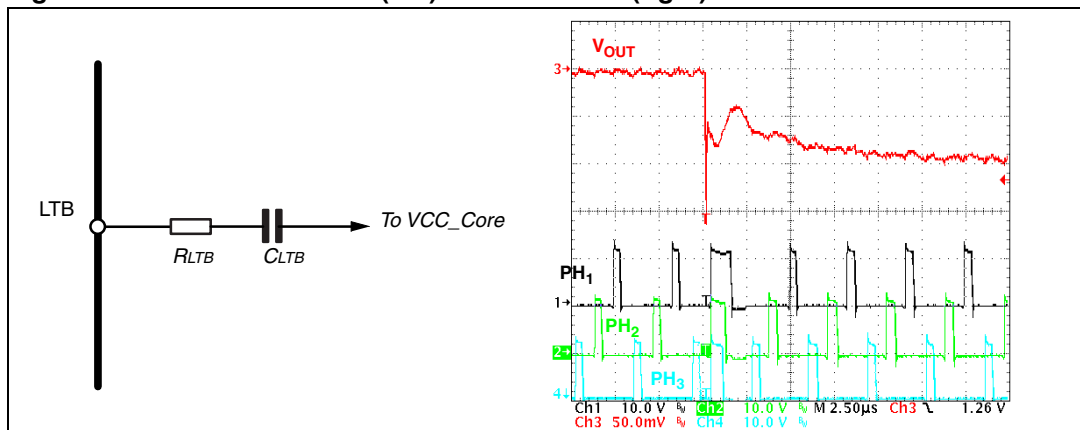

15 Dynamic VID transitions

The device is able to manage dynamic VID code changes that allow output voltage modification during normal device operation.

OVP and UVP signals are masked during every VID transition and they are re-activated after the transition finishes with a 15 μ s (typ) delay to prevent from false triggering due to the transition.

When changing dynamically the regulated voltage (D-VID), the system needs to charge or discharge the output capacitor accordingly. This means that an extra-current I_{D-VID} needs to be delivered, especially when increasing the output regulated voltage and it must be considered when setting the overcurrent threshold.

This current can be estimated using the following relationships:

$$I_{D-VID} = C_{OUT} \cdot \frac{dV_{OUT}}{dT_{VID}}$$

where dV_{OUT} is the selected DAC LSB (6.25 mV for VR11.1) and T_{VID} is the time interval between each LSB transition (externally driven).

Overcoming the OC threshold during the dynamic VID causes the device to enter the constant current limitation slowing down the output voltage dV/dt also causing the failure in the D-VID test.

In order to avoid this situation the device automatically increases the OCP threshold to 150% of the selected OCP threshold during every VID transition (adding an extra 15 μ s of delay).

If the DVID (dynamic VID change) happens during low power state (PSI low), the device turns on all the N phases in order to follow the DVID change reducing the over/under shoot of the output voltage.

L6716 checks for VID code modifications ([See Figure 17](#)) on the rising edge of an internal additional DVID-clock and waits for a confirmation on the following falling edge. Once the new code is stable, on the next rising edge, the reference starts stepping up or down in LSB increments every VID-clock cycle until the new VID code is reached. During the transition, VID code changes are ignored; the device re-starts monitoring VID after the transition has finished on the next rising edge available. VID-clock frequency (F_{DVID}) is in the range of 1.8 MHz to assure compatibility with the specifications.

Note: *If the new VID code is more than 1 LSB different from the previous, the device will execute the transition stepping the reference with the DVID-clock frequency F_{DVID} until the new code has reached: for this reason it is recommended to carefully control the VID change rate in order to carefully control the slope of the output voltage.*

Figure 17. Dynamics VID transitions

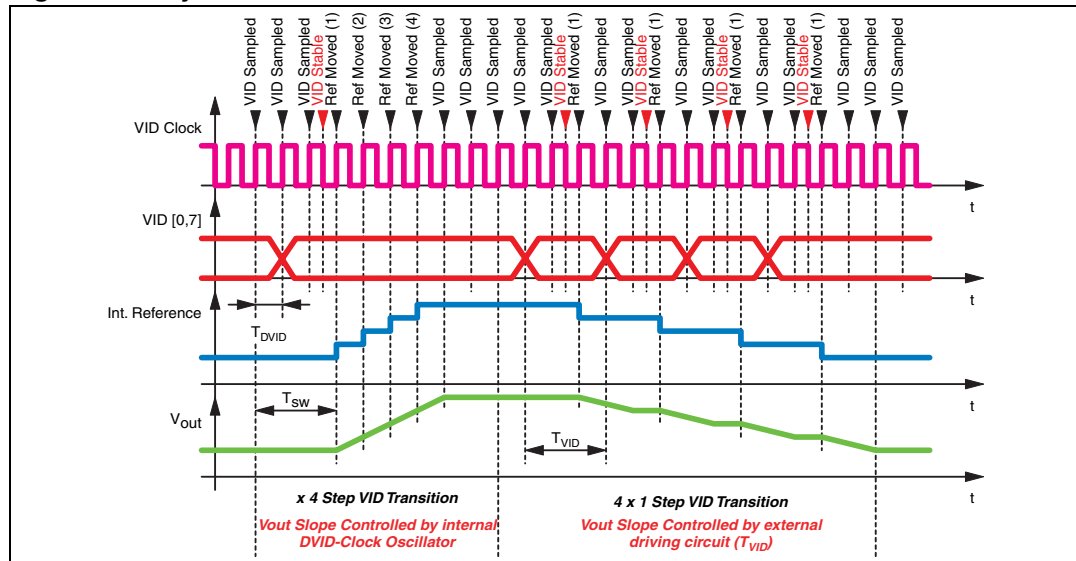

16 Enable and disable

L6716 has three different supplies: VCC pin to supply the internal control logic, VCCDR to supply the low side drivers and BOOTx to supply the high side drivers.

If the voltage at pin VCC is not above the turn on threshold specified in the [Section 4: Electrical characteristics on page 14](#), the device is shut down: all drivers keep the MOSFETs off to show high impedance to the load.

Once the device is correctly supplied, proper operation is assured and the device can be driven by the OUTEN pin to control the power sequencing. Setting the pin free, the device implements a soft-start up to the programmed voltage. Shorting the pin to SGND, it resets the device (SS_END is shorted to SGND in this condition) from any latched condition and also disables the device keeping all the MOSFET turned off to show high impedance to the load.

17 Soft-start

L6716 implements a soft-start to smoothly charge the output filter avoiding high in-rush currents to be required to the input power supply. The device increases the reference from zero up to the programmed value and the output voltage increases accordingly with closed loop regulation.

The device implements soft-start only when all the power supplies are above their own turn-on thresholds and the OUTEN pin is set free.

At the end of the digital soft-start, SS_END signal is set free.

Protections are active during soft-start: under voltage is enabled when the reference voltage reaches 0.6 V while overvoltage is always enabled.

Note: If the PSI is already low during the start-up, the device implements the soft-start using the N phases selected through PWM4 pin. When the soft-start is finished the device turns OFF some phases in according to the PSI strategy.

Figure 18. Soft-start

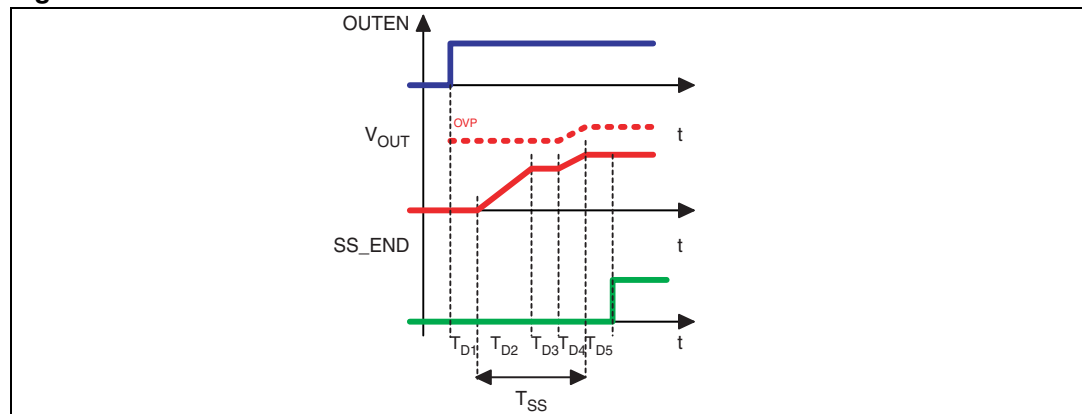

Once L6716 receives all the correct supplies and enables, it initiates the Soft-Start phase with a $T_{D1}=1.5$ ms (typ) delay. After that, the reference ramps up to $V_{BOOT} = 1.081$ V (1.100 V - 19 mV) in T_{D2} according to the SSOSC settings and waits for $T_{D3} = 200$ μ sec (typ) during which the device reads the VID lines. Output voltage will then ramp up to the programmed value in T_{D4} with the same slope as before (see [Figure 18](#)).

SSOSC defines the frequency of an internal additional soft-start-oscillator used to step the reference from zero up to the programmed value; this oscillator is independent from the main oscillator whose frequency is programmed through the OSC pin.

The current flowing from SSOSC pin before the end of soft-start is used to program the desired soft-start time (T_{SS}).

After that the soft-start is finished the current flowing from SSOSC pin is used to program the maximum LTB switching frequency (F_{LIMIT}).

In the [Figure 19](#) is shown the SSOSC connection in order to select both parameter (T_{SS} and F_{LIMIT}) in independent way.

In particular, it allows to precisely programming the start-up time up to V_{BOOT} (T_{D2}) since it is a fixed voltage independent by the programmed VID. Total soft-start time dependence on the programmed VID results (see [Figure 20](#)).

Note: If during T_{D3} the programmed VID selects an output voltage lower than V_{BOOT} , the output voltage will ramp to the programmed voltage starting from V_{BOOT} .

Figure 19. SSOSC connection

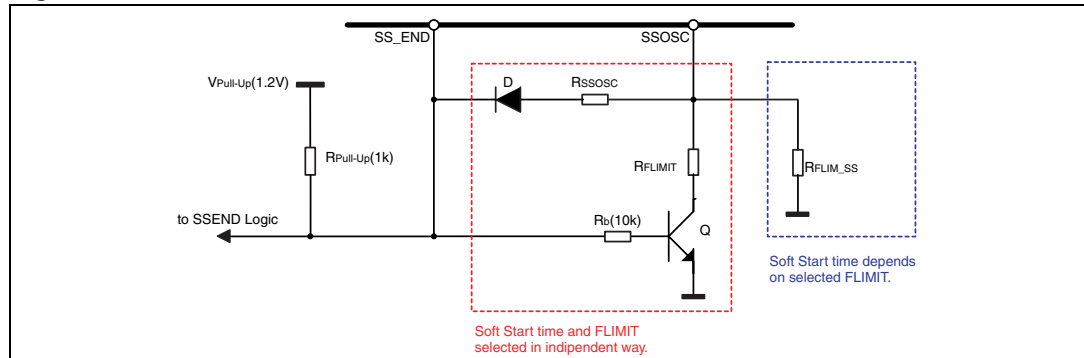

$$R_{SSOSC}[\text{k}\Omega] = T_{D2}[\mu\text{s}] \cdot 40 \cdot 10^{-3} \cdot \left[\frac{1.24 - V_{DIODE}[\text{V}]}{1.24} \right]$$

$$T_{SS}[\mu\text{s}] = 200[\mu\text{s}] + \begin{cases} \frac{R_{SSOSC}[\text{k}\Omega]}{40 \cdot 10^{-3}} \cdot \frac{1.24}{1.24 - V_{DIODE}[\text{V}]} \cdot \frac{V_{SS}}{V_{BOOT}} & \text{if } (V_{SS} > V_{BOOT}) \\ \frac{R_{SSOSC}[\text{k}\Omega]}{40 \cdot 10^{-3}} \cdot \frac{1.24}{1.24 - V_{DIODE}[\text{V}]} \cdot \left[1 + \frac{V_{SS}}{V_{BOOT}} \right] & \text{if } (V_{SS} < V_{BOOT}) \end{cases}$$

where T_{SS} is the time spent to reach the programmed voltage V_{SS} and R_{SSOSC} the resistor connected between SSOSC and SS_END (through a signal diode) in $\text{k}\Omega$.

Figure 20. Soft-start time (T_{SS}) when using R_{SSOSC} , diode versus SS_END

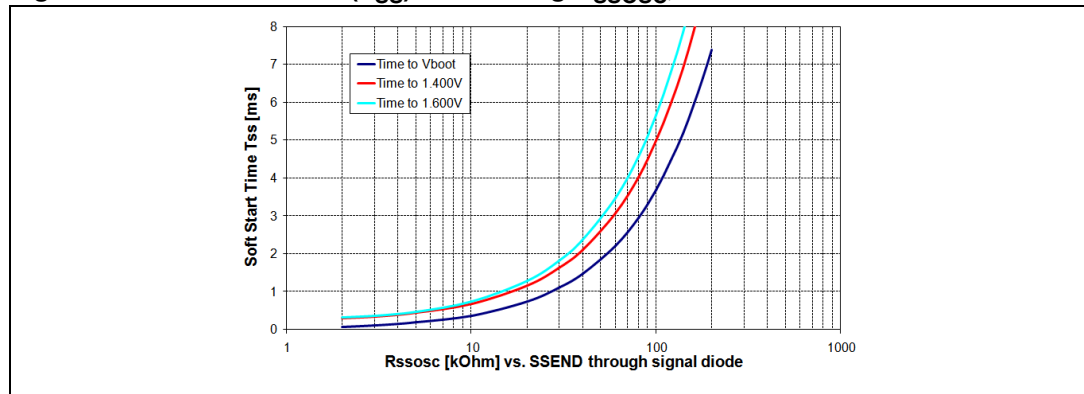

Use the following relationship to select the maximum LTB switching frequency:

$$R_{FLIMIT}[\text{k}\Omega] = \frac{2.11 \cdot 10^4}{F_{LIMIT}[\text{kHz}]} \cdot \left[\frac{1.24 - V_{CE}^{BJT}[\text{V}]}{1.24} \right]$$

where F_{LIMIT} has to be higher than the F_{SW} switching frequency.

Note: Connecting SSOSC pin to SGND through only the R_{FLIM_SS} resistor (blue one network in Figure 19), the Soft-start time depends on the F_{LIMIT} selected.

In this case use the following relationship to select F_{LIMIT} and as a consequence the soft-start time:

$$R_{FLIM_SS}[k\Omega] = \frac{2.11 \cdot 10^4}{F_{LIMIT}[kHz]}$$

$$T_{D2}[\mu s] = \frac{5.275 \cdot 10^5}{F_{LIMIT}[kHz]}$$

Figure 21. Soft-start time (T_{SS}) vs F_{LIMIT} when using R_{FLIM_SS} resistor versus SGND

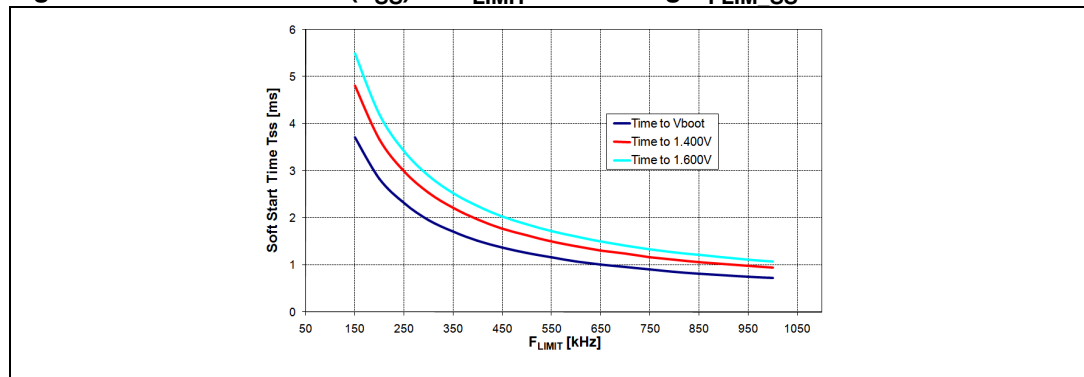

17.1 Low-side-less startup

In order to avoid any kind of negative undershoot on the load side during start-up, L6716 performs a special sequence in enabling LS driver to switch: during the soft-start phase, the LS driver results disabled (LS=OFF) until the HS starts to switch. This avoid the dangerous negative spike on the output voltage that can happen if starting over a pre-biased output (see Figure 22).

This particular feature of the device masks the LS turn-on only from the control loop point of view: protections are still allowed to turn-ON the LS MOSFET in case of overvoltage if needed.

Figure 22. Low-side-less start-up comparison with LS-less start-up

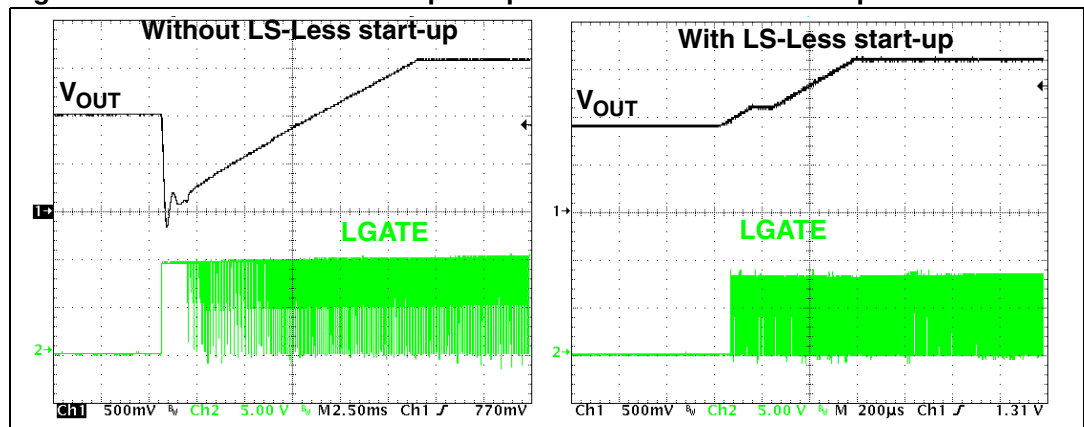

18 Output voltage monitor and protections

L6716 monitors through pin VSEN the regulated voltage in order to manage the OVP and UVP conditions. Protections are active also during soft-start ([Section 17: Soft-start on page 36](#)) while they are masked during D-VID transitions with an additional 67 μs delay after the transition has finished to avoid false triggering.

18.1 Undervoltage

If the output voltage monitored by VSEN drops more than 600 mV (typ) below the programmed reference for more than one clock period, the L6716:

- Permanently turns OFF all the MOSFETs (PWM4 is forced in high impedance when external driver is used)
- Drives the OSC/ FAULT pin high (3.3 V typ).
- Power supply or OUTEN pin cycling is required to restart operations.

18.2 Preliminary overvoltage

To provide a protection while VCC is below the $UVLO_{VCC}$ threshold is fundamental to avoid damage to the CPU in case of failed HS MOSFETs. In fact, since the device is supplied from the 12 V bus, it is basically “blind” for any voltage below the turn-on threshold ($UVLO_{VCC}$). In order to give full protection to the load, a preliminary-OVP protection is provided while VCC is within $UVLO_{VCC}$ and $UVLO_{Pre-OVP}$

This protection turns-on the low side MOSFETs as long as the VSEN pin voltage is greater than 1.800 V with a 350 mV hysteresis. When set, the protection drives the LS MOSFET with a gate-to-source voltage depending on the voltage applied to VCC. This protection depends also on the OUTEN pin status as detailed in [Figure 23](#).

A simple way to provide protection to the output in all conditions when the device is OFF (then avoiding the unprotected red region in [Figure 23-Left](#)) consists in supplying the controller through the 5 V_{SB} bus as shown in [Figure 23-Right](#): 5 V_{SB} is always present before +12 V and, in case of HS short, the LS MOSFET is driven with 5 V assuring a reliable protection of the load.

Figure 23. Output voltage protections and typical principle connections

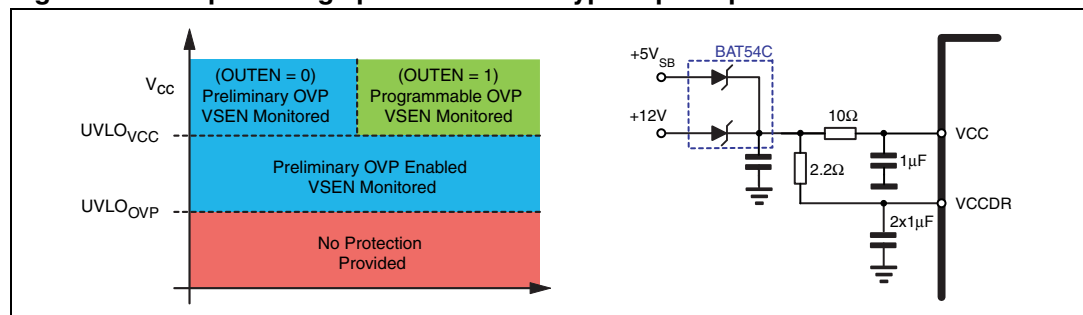

Note: The device turns ON only LS MOSFETs of Phase1-Phase3 if the Pre-OVP is detected before that VCC is higher than $UVLO_{VCC}$. (The device reads PWM4 information if the VCC is higher than $UVLO_{VCC}$).

18.3 Overvoltage and programmable OVP

Once VCC crosses the turn-ON threshold and the device is enabled (OUTEN = 1), L6716 provides an overvoltage protection: when the voltage sensed by VSEN overcomes the OVP threshold (OVP_{TH}), the controller:

- Permanently turns OFF all the high-side MOSFETs.
- Permanently turns ON all the low-side MOSFETs (PWM4 is forced low when external driver is used) in order to protect the load.
- Drives the OSC/ FAULT pin high (3.3 V typ).
- Power supply or OUTEN pin cycling is required to restart operations.

The OVP threshold can be also programmed through the OVP pin: leaving the pin floating, it is internally pulled-up and the OVP threshold is set to VID+150 mV (typ).

Connecting the OVP pin to SGND through a resistor R_{OVP} the OVP threshold becomes the voltage present at the pin. Since the OVP pin sources a constant I_{OVP} = 20 μA current (see Table 5), the programmed voltage becomes:

$$OVP_{TH} = R_{OVP} \cdot 20\mu A \Rightarrow R_{OVP} = \frac{OVP_{TH}}{20\mu A}$$

Filter OVP pin with 100 pF (max) vs. SGND.

Table 9. Overvoltage protection threshold

OVP pin	Thresholds	OVP threshold
Floating	Tracking	OVP _{TH} = VID + 175 mV (typ)
R _{OVP} to SGND	Fixed	OVP _{TH} = R _{OVP} * 20 μA (typ)

Overvoltage protections is always active during the soft-start, as shown in the following picture:

Figure 24. OVP threshold during soft-start for tracking (left) and fixed (right) mode

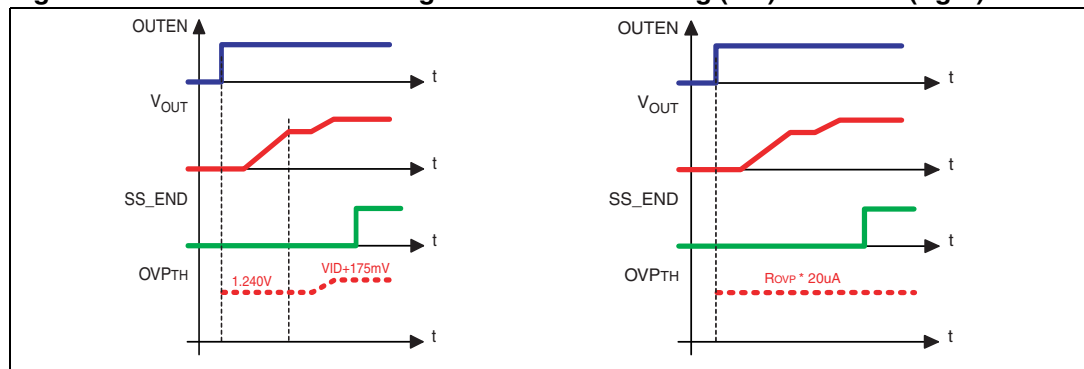

Note: When VR10/VR11 table is selected (OVP pin to SGND) the OVP threshold becomes 1.800 V (typ) fixed.

18.4 Overcurrent protection

The device limits the peak the inductor current entering in constant current until setting UVP as below explained.

The overcurrent threshold has to be programmed, by designing the R_{OCSET} resistors as shown in the [Figure 25](#), to a safe value, in order to be sure that the device doesn't enter OCP during normal operation of the device. This value must take into consideration also the extra current needed during the Dynamic VID Transition I_{D-VID} (See [“Dynamic VID transitions” Section](#) for details):

$$I_{OUT}^{OCP} > I_{OUT}^{MAX} + I_{D-VID}$$

The device detects an overcurrent when the I_{INFOx} overcome the threshold I_{OCTH} externally programmable through OCSET pin.

$$I_{OCTH} = \frac{V_{OCSET}}{R_{OCSET}} = \frac{1.240V(typ)}{R_{OCSET}}$$

$$I_{INFOx}^{OCP} = \frac{DCR}{R_g} \cdot \left(\frac{I_{OUT}^{OCP}}{N} + \frac{\Delta I_L}{2} \right)$$

where ΔI_L is the inductor ripple current (peak-to-peak).

Since the device always senses the current across the inductor, the I_{OCTH} crossing will happen during the HS conduction time: as a consequence of OCP detection, the device will turn OFF the HS MOSFET and turns ON the LSMOSFET of that phase until I_{INFOx} re-cross the threshold or until the next clock cycle. This implies that the device limits the peak of the inductor current.

In any case, the inductor current won't overcome the I_{OCPx} value and this will represent the maximum peak value to consider in the OC design.

The device works in constant-current, and the output voltage decreases as the load increase, until the output voltage reaches the UVP threshold. When this threshold is crossed, all MOSFETs are turned off and the device stops working. Cycle the power supply or the OUTEN pin to restart operation.

Figure 25. Overcurrent protection connection

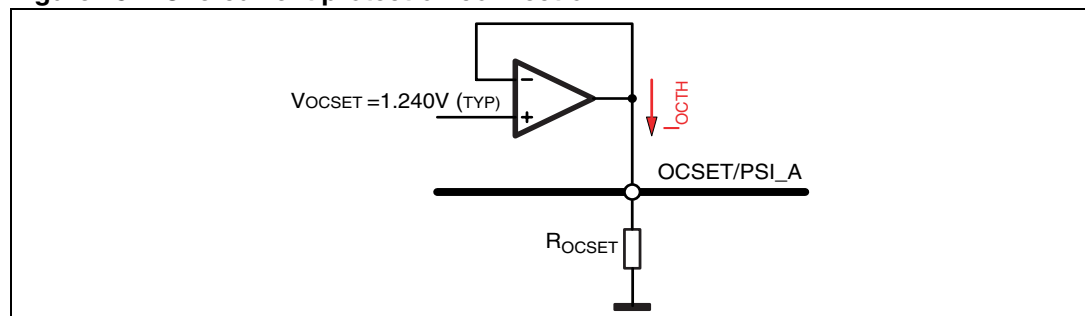

Note: In order to avoid the OCP intervention during the DVID, the device automatically increases the OCP threshold to 150% of the selected OCP threshold during every VID transition (adding an extra 15 μs of delay).

Since the device reads the current information across inductor DCR, the process spread and temperature variations of these sensing elements has to be considered. Also the programmable threshold spread (I_{OUTH} current spread as a consequence of V_{OCSET} spread, See “Electrical characteristics” Section) has to be considered for the R_{OCSET} design:

$$R_{OCSET} = \frac{V_{OCSET(MIN)}}{\frac{DCR(MAX)}{Rg} \cdot \left(\frac{I_{OUT(OCP)}}{N} + \frac{\Delta IL}{2} \right)}$$

The OCSET pin is also used to select the number of phases when PSI mode is asserted.

To select the desired OCP threshold and number of phase during PSI mode, refer to the following table.

Table 10. # phases when PSI is asserted

# phase normal mode (N)	# phase PSI mode (N_PSI)	Phases enabled	R _{OCSET}
4	1	PHASE1	$R_{OCSET} = \frac{V_{OCSET(MIN)}}{\left[\frac{DCR(MAX)}{Rg} \cdot \left(\frac{I_{OUT(OCP)}}{N} + \frac{\Delta IL}{2} \right) \right] + 77\mu A}$
	2	PHASE1 PHASE3	$R_{OCSET} = \frac{V_{OCSET(MIN)}}{\frac{DCR(MAX)}{Rg} \cdot \left(\frac{I_{OUT(OCP)}}{N} + \frac{\Delta IL}{2} \right)}$
3	1	PHASE1	$R_{OCSET} = \frac{V_{OCSET(MIN)}}{\frac{DCR(MAX)}{Rg} \cdot \left(\frac{I_{OUT(OCP)}}{N} + \frac{\Delta IL}{2} \right)}$
	2	PHASE1 PHASE3	$R_{OCSET} = \frac{V_{OCSET(MIN)}}{\left[\frac{DCR(MAX)}{Rg} \cdot \left(\frac{I_{OUT(OCP)}}{N} + \frac{\Delta IL}{2} \right) \right] + 77\mu A}$
2	1	PHASE1	$R_{OCSET} = \frac{V_{OCSET(MIN)}}{\frac{DCR(MAX)}{Rg} \cdot \left(\frac{I_{OUT(OCP)}}{N} + \frac{\Delta IL}{2} \right)}$
	2	N. A.	Do not use this condition (Not applicable)

18.5 Feedback disconnection

L6716 allows to protect the load from dangerous overvoltage also in case of feedback disconnection. The device is able to recognize both FB pin and FBG pin disconnections, as shown in the [Figure 26](#).

When VSEN pin is more than 500 mV higher than VPROG, the device recognize a FBG disconnections. Viceversa, when CS1- is more than 700 mV higher than VSEN, the device recognize a FB disconnection.

In both of the previous condition the device stops switching with all the MOSFETs permanently OFF and drives high the OSC/FAULT pin. The condition is latched until VCC or OUTEN cycled.

Figure 26. Feedback disconnection

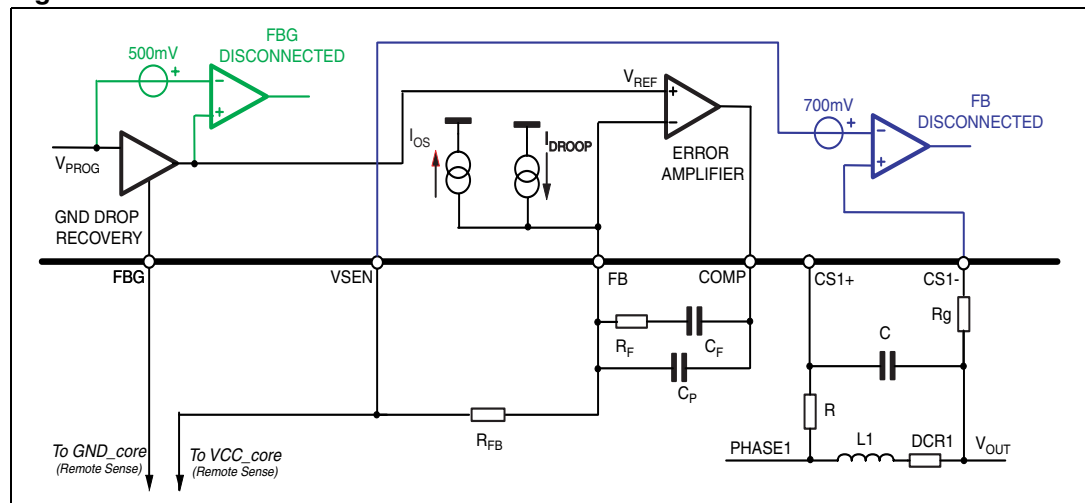

19 Low power state management and PSI#

The device is able to manage the low power state mode: when the PSI is driven low (PSI is active low) the device turns OFF some phase in order to increase the system efficiency.

The number of phases active when low power state is active depends on the OCSET/PSI_A pin (through R_{OCSET} versus SGND) as shown in the following table:

Table 11: # phases when PSI is asserted

# phase normal mode (N)	# phase PSI mode (N_PSI)	Phases enabled	R _{OCSET}
4	1	PHASE1	$R_{OCSET} = \frac{V_{OCSET(MIN)}}{\left[\frac{DCR(MAX)}{R_g} \cdot \left(\frac{I_{OUT(OCP)}}{N} + \frac{\Delta IL}{2} \right) \right] + 77\mu A}$
	2	PHASE1 PHASE3	$R_{OCSET} = \frac{V_{OCSET(MIN)}}{\frac{DCR(MAX)}{R_g} \cdot \left(\frac{I_{OUT(OCP)}}{N} + \frac{\Delta IL}{2} \right)}$
3	1	PHASE1	$R_{OCSET} = \frac{V_{OCSET(MIN)}}{\frac{DCR(MAX)}{R_g} \cdot \left(\frac{I_{OUT(OCP)}}{N} + \frac{\Delta IL}{2} \right)}$
	2	PHASE1 PHASE3	$R_{OCSET} = \frac{V_{OCSET(MIN)}}{\left[\frac{DCR(MAX)}{R_g} \cdot \left(\frac{I_{OUT(OCP)}}{N} + \frac{\Delta IL}{2} \right) \right] + 77\mu A}$
2	1	PHASE1	$R_{OCSET} = \frac{V_{OCSET(MIN)}}{\frac{DCR(MAX)}{R_g} \cdot \left(\frac{I_{OUT(OCP)}}{N} + \frac{\Delta IL}{2} \right)}$
	2	N. A.	Do not use this condition (Not applicable)

If DVID (dynamic VID change) happens during low power state (PSI low), the device turns on all the N phases in order to follow the DVID change reducing the over/under shoot of the output voltage.

Note: If the PSI is already low during the start-up, the device implements the soft-start using the N phases selected through PWM4 pin. When the soft-start is finished the device turns OFF some phases in according to the PSI strategy.

20 Oscillator

L6716 embeds two-to-four phase oscillator with optimized phase-shift (180°/120°/90° phase-shift) in order to reduce the input rms current and optimize the output filter definition.

The internal oscillator generates the triangular waveform for the PWM charging and discharging with a constant current an internal capacitor. The switching frequency for each channel, F_{SW} , is internally fixed at 200 kHz so that the resulting switching frequency at the load side results in being multiplied by N (number of phases).

The current delivered to the oscillator is typically 25 μ A (corresponding to the free running frequency $F_{SW} = 200$ kHz) and it may be varied using an external resistor (R_{OSC}) connected between the OSC/FAULT pin and SGND or VCC (or a fixed voltage greater than 1.24 V). Since the OSC/FAULT pin is fixed at 1.240 V, the frequency is varied proportionally to the current sunk (forced) from (into) the pin considering the internal gain of 9.1 kHz/ μ A.

In particular connecting R_{OSC} to SGND the frequency is increased (current is sunk from the pin), while connecting R_{OSC} to VCC = 12 V the frequency is reduced (current is forced into the pin), according the following relationships:

R_{OSC} vs. SGND

$$F_{SW} = 200(\text{kHz}) + \frac{1.240\text{V}}{R_{OSC}(\text{k}\Omega)} \cdot 9.1 \frac{\text{kHz}}{\mu\text{A}} = 200(\text{kHz}) + \frac{11.284 \cdot 10^3}{R_{OSC}(\text{k}\Omega)} \Rightarrow R_{OSC}(\text{k}\Omega) = \frac{11.284 \cdot 10^3}{F_{SW}(\text{kHz}) - 200(\text{kHz})} [\text{k}\Omega]$$

R_{OSC} vs. +12 V

$$F_{SW} = 200(\text{kHz}) - \frac{12\text{V} - 1.240\text{V}}{R_{OSC}(\text{k}\Omega)} \cdot 9.1 \frac{\text{kHz}}{\mu\text{A}} = 200(\text{kHz}) - \frac{9.7916 \cdot 10^4}{R_{OSC}(\text{k}\Omega)} \Rightarrow R_{OSC}(\text{k}\Omega) = \frac{9.7916 \cdot 10^4}{200(\text{kHz}) - F_{SW}(\text{kHz})} [\text{k}\Omega]$$

Maximum programmable switching frequency per phase must be limited to 1 MHz to avoid minimum T_{on} limitation. Anyway, device power dissipation must be checked prior to design high switching frequency systems.

Figure 27. R_{OSC} vs. switching frequency

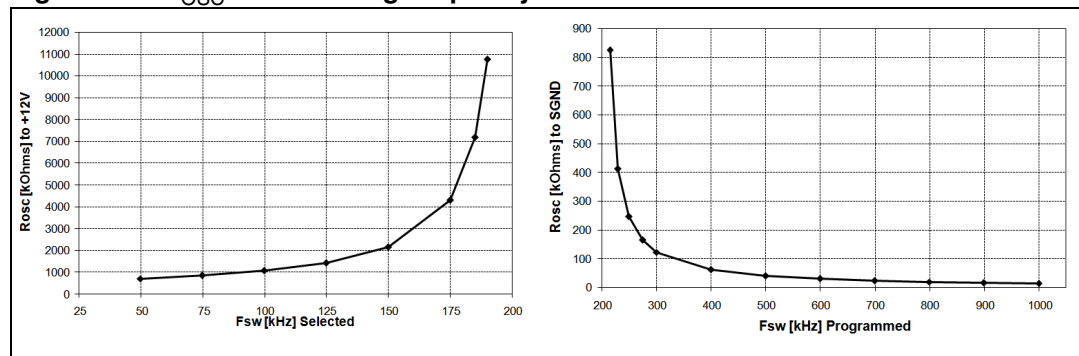

21 Driver section

The integrated high-current drivers allow using different types of power MOS (also multiple MOS to reduce the equivalent $R_{ds(ON)}$), maintaining fast switching transition.

The drivers for the high-side MOSFETs use BOOTx pins for supply and PHASEx pins for return. The drivers for the low-side MOSFETs use VCCDR pin for supply and PGND pin for return. A minimum voltage at VCCDR pin is required to start operations of the device.

The controller embodies a sophisticated anti-shoot-through system to minimize low side body diode conduction time maintaining good efficiency saving the use of Schottky diodes: when the high-side MOSFET turns off, the voltage on its source begins to fall; when the voltage reaches 2 V, the low-side MOSFET gate drive is suddenly applied. When the low-side MOSFET turns off, the voltage at LGATEx pin is sensed. When it drops below 1 V, the high-side MOSFET gate drive is suddenly applied.

If the current flowing in the inductor is negative, the source of high-side MOSFET will never drop. To allow the turning on of the low-side MOSFET even in this case, a watchdog controller is enabled: if the source of the high-side MOSFET doesn't drop, the low side MOSFET is switched on so allowing the negative current of the inductor to recirculate. This mechanism allows the system to regulate even if the current is negative.

The BOOTx and VCCDR pins are separated from IC's power supply (VCC pin) as well as signal ground (SGND pin) and power ground (PGND pin) in order to maximize the switching noise immunity.

22 System control loop compensation

The control loop is composed by the current sharing control loop (see [Figure 9](#)) and the average current mode control loop. Each loop gives, with a proper gain, the correction to the PWM in order to minimize the error in its regulation: the current sharing control loop equalize the currents in the inductors while the average current mode control loop fixes the output voltage equal to the reference programmed by VID. [Figure 28](#) shows the block diagram of the system control loop.

The system control loop is reported in [Figure 29](#). The current information I_{DROOP} sourced by the FB pin flows into R_{FB} implementing the dependence of the output voltage from the read current.

Figure 28. Main control loop

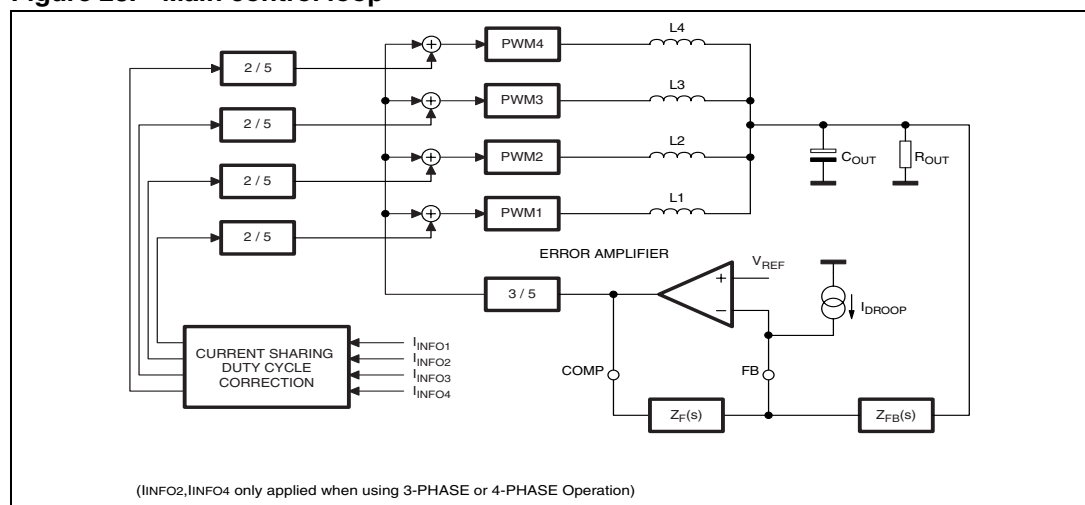

The system can be modeled with an equivalent single phase converter which only difference is the equivalent inductor L/N (where each phase has an L inductor). The control loop gain results (obtained opening the loop after the COMP pin):

$$G_{LOOP}(s) = -\frac{PWM \cdot Z_F(s) \cdot (R_{DROOP} + Z_P(s))}{[Z_P(s) + Z_L(s)] \cdot \left[\frac{Z_F(s)}{A(s)} + \left(1 + \frac{1}{A(s)}\right) \cdot R_{FB} \right]}$$

Where:

DCR is the inductor parasitic resistance;

is the equivalent output resistance determined by the droop function;

$$R_{DROOP} = \frac{DCR}{R_g} \cdot R_{FB}$$

$Z_P(s)$ is the impedance resulting by the parallel of the output capacitor (and its ESR) and the applied load R_O

$Z_F(s)$ is the compensation network impedance

$Z_L(s)$ is the parallel of the N inductor impedance

$A(s)$ is the error amplifier gain

$$PWM = \frac{3}{5} \cdot \frac{V_{IN}}{\Delta V_{OSC}}$$

is the PWM transfer function where ΔV_{OSC} is the oscillator ramp amplitude and has a typical value of 1.5 V.

Removing the dependence from the error amplifier gain, so assuming this gain high enough, and with further simplifications, the control loop gain results:

$$G_{LOOP}(s) = \frac{3}{5} \cdot \frac{V_{IN}}{\Delta V_{OSC}} \cdot \frac{Z_F(s)}{R_{FB}} \cdot \frac{R_O + R_{DROOP}}{R_O + \frac{R_L}{N}} \cdot \frac{1 + s \cdot C_O \cdot (R_{DROOP} // R_O + ESR)}{s^2 \cdot C_O \cdot \frac{L}{N} + s \cdot \left[\frac{L}{N \cdot R_O} + C_O \cdot ESR + C_O \cdot \frac{R_L}{N} \right] + 1}$$

The system control loop gain (see [Figure 28](#)) is designed in order to obtain a high DC gain to minimize static error and to cross the 0 dB axes with a constant -20 dB/dec slope with the desired crossover frequency ω_T . Neglecting the effect of $Z_F(s)$, the transfer function has one zero and two poles; both the poles are fixed once the output filter is designed (LC filter resonance ω_{LC}) and the zero (ω_{ESR}) is fixed by ESR and the Droop resistance.

Figure 29. Equivalent control loop block diagram (left) and bode diagram (right)

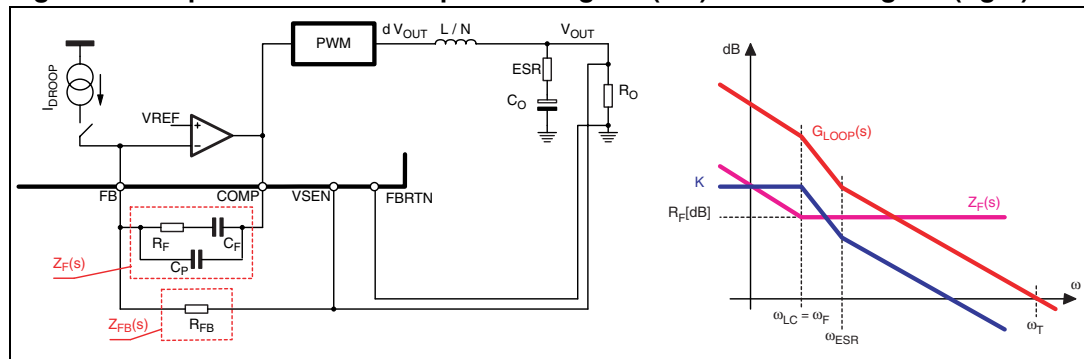

To obtain the desired shape an R_F - C_F series network is considered for the $Z_F(s)$ implementation. A zero at $\omega_F = 1/R_F C_F$ is then introduced together with an integrator. This integrator minimizes the static error while placing the zero ω_F in correspondence with the L-C resonance assures a simple -20 dB/dec shape of the gain.

In fact, considering the usual value for the output filter, the LC resonance results to be at frequency lower than the above reported zero.

Compensation network can be simply designed placing $\omega_F = \omega_{LC}$ and imposing the crossover frequency ω_T as desired obtaining (always considering that ω_T might be not higher than $1/10^{th}$ of the switching frequency F_{SW}):

$$R_F = \frac{R_{FB} \cdot \Delta V_{OSC}}{V_{IN}} \cdot \frac{5}{3} \cdot \omega_T \cdot \frac{L}{N \cdot (R_{DROOP} + ESR)} \quad C_F = \frac{\sqrt{C_O \cdot \frac{L}{N}}}{R_F}$$

Moreover, it is suggested to filter the high frequency ripple on the COMP pin adding also a capacitor between COMP pin and FB pin (it does not change the system bandwidth):

$$C_P = \frac{1}{2 \cdot \pi \cdot R_F \cdot N \cdot F_{SW}}$$

23 Tolerance band (TOB) definition

Output voltage load-line varies considering component process variation, system temperature extremes, and age degradation limits. Moreover, individual tolerance of the components also varies among designs: it is then possible to define a manufacturing tolerance band (TOB_{Manuf}) that defines the possible output voltage spread across the nominal load line characteristic.

TOB_{Manuf} can be sliced into different three main categories: controller tolerance, external current sense circuit tolerance and time constant matching error tolerance. All these parameters can be composed thanks to the RSS analysis so that the manufacturing variation on TOB results to be:

$$TOB_{\text{Manuf}} = \sqrt{TOB_{\text{Controller}}^2 + TOB_{\text{CurrSense}}^2 + TOB_{\text{TCMatching}}^2}$$

Output voltage ripple ($V_P=V_{PP}/2$) and temperature measurement error (V_{TC}) must be added to the manufacturing TOB in order to get the system tolerance band as follow:

$$TOB = TOB_{\text{Manuf}} + V_P + V_{TC}$$

All the component spreads and variations are usually considered at 3σ . Here follows an explanation on how to calculate these parameters for a reference L6716 application.

23.1 Controller tolerance ($TOB_{\text{Controller}}$)

It can be further sliced as follow:

Reference tolerance. L6716 is trimmed during the production stage to ensure the output voltage to be within $k_{VID} = \pm 0.5\%$ over temperature and line variations. In addition, the device automatically adds a -19 mV offset avoiding the use of any external component. This offset is already included during the trimming process in order to avoid the use of any external circuit to generate this offsets and, moreover, avoiding the introduction of any further error to be considered in the TOB calculation.

Current reading circuit. The device reads the current flowing across the inductor DCR by using its dedicated differential inputs. The current sourced by the VRD is then reproduced and sourced from the FB pin scaled down by a proper designed gain as follow:

$$I_{\text{DROOP}} = \frac{DCR}{R_g} \cdot I_{\text{OUT}}$$

This current multiplied by the R_{FB} resistor connected from FB pin vs. the load allows programming the droop function according to the selected DCR/R_g gain and R_{FB} resistor. Deviations in the current sourced due to errors in the current reading, impacts on the output voltage depending on the size of R_{FB} resistor. The device is trimmed during the production stage in order to guarantee a maximum deviation of $k_{IFB} = \pm 3 \mu\text{A}$ from the nominal value.

Controller tolerance results then to be:

$$TOB_{\text{Controller}} = \sqrt{[(VID - 19\text{mV}) \cdot k_{VID}]^2 + (k_{IDROOP} \cdot R_{FB})^2}$$

23.2 External current sense circuit tolerance ($TOB_{CurrSense}$)

It can be further sliced as follow:

Inductor DCR tolerance (k_{DCR}). Variations in the inductor DCR impacts on the output voltage since the device reads a current that is different from the real current flowing into the sense element. As a results, the controller will source a I_{DROOP} current different from the nominal. The results will be an AVP different from the nominal in the same percentage as the DCR is different from the nominal. Since all the sense elements results to be in parallel, the error related to the inductor DCR has to be divided by the number of phases (N).

Trans-conductance resistors tolerance (k_{Rg}). Variations in the Rg resistors impacts in the current reading circuit gain and so impacts on the output voltage. The results will be an AVP different from the nominal in the same percentage as the Rg is different from the nominal. Since all the sense elements results to be in parallel, and so the three current reading circuits, the error related to the Rg resistors has to be divided by the number of phases (N).

NTC Initial Accuracy (k_{NTC_0}). Variations in the NTC nominal value at room temperature used for the thermal compensation impacts on the AVP in the same percentage as before. In addition, the benefit of the division by the number of phases N cannot be applied in this case.

NTC temperature accuracy (k_{NTC}). NTC variations from room to hot also impacts on the output voltage positioning. The impact is bigger as big is the temperature variation from room to hot (ΔT).

All these parameters impacts the AVP, so they must be weighted on the maximum voltage swing from zero load up to the maximum electrical current (V_{AVP}). Total error from external current sense circuit results:

$$TOB_{CurrSense} = \sqrt{V_{AVP}^2 \cdot \left[\frac{k_{DCR}^2}{N} + \frac{k_{Rg}^2}{N} + k_{NTC0}^2 + \left(\frac{\alpha \cdot \Delta T \cdot k_{NTC}}{DCR} \right)^2 \right]}$$

23.3 Time constant matching error tolerance ($TOB_{TCMatching}$)

Inductance and capacitance tolerance (k_L, k_C). Variations in the inductance value and in the value of the capacitor used for the time constant matching causes over/under shoots after a load transient appliance. This impacts the output voltage and then the TOB. Since all the sense elements results to be in parallel, the error related to the time constant mismatch has to be divided by the number of phases (N).

Capacitance temperature variations (k_{Ct}). The capacitor used for time constant matching also vary with temperature (ΔT_C) impacting on the output voltage transients ad before. Since all the sense elements results to be in parallel, the error related to the time constant mismatch has to be divided by the number of phases (N).

All these parameters impact the dynamic AVP, so they must be weighted on the maximum dynamic voltage swing (I_{dyn}). Total error due to time constant mismatch results:

$$TOB_{TCMatching} = \sqrt{V_{AVPDyn}^2 \cdot \frac{k_L^2 + k_C^2 + (k_{Ct} \cdot \Delta T_C)^2}{N}}$$

23.4 Temperature measurement error (V_{TC})

Error in the measured temperature (for thermal compensation) impacts on the output regulated voltage since the correction from the compensation circuit is not what required to keep the output voltage flat.

The measurement error (ϵ_{Temp}) must be multiplied by the copper temp coefficient (α) and compared with the sensing resistance (R_{SENSE}): this percentage affects the AVP voltage as follow:

$$V_{TC} = \frac{\alpha \cdot \epsilon_{Temp}}{R_{SENSE}} \cdot V_{AVP}$$

24 Layout guidelines

Since the device manages control functions and high-current drivers, layout is one of the most important things to consider when designing such high current applications. A good layout solution can generate a benefit in lowering power dissipation on the power paths, reducing radiation and a proper connection between signal and power ground can optimize the performance of the control loops.

Two kind of critical components and connections have to be considered when laying out a VRM based on L6716: power components and connections and small signal components connections.

24.1 Power components and connections

These are the components and connections where switching and high continuous current flows from the input to the load. The first priority when placing components has to be reserved to this power section, minimizing the length of each connection and loop as much as possible. To minimize noise and voltage spikes (EMI and losses) these interconnections must be a part of a power plane and anyway realized by wide and thick copper traces: loop must be anyway minimized. The critical components, i.e. the power transistors, must be close one to the other. The use of multi-layer printed circuit board is recommended.

Figure 30 shows the details of the power connections involved and the current loops. The input capacitance (C_{IN}), or at least a portion of the total capacitance needed, has to be placed close to the power section in order to eliminate the stray inductance generated by the copper traces. Low ESR and ESL capacitors are preferred, MLCC are suggested to be connected near the HS drain.

Figure 30. Power connections and related connections layout (same for all phases)

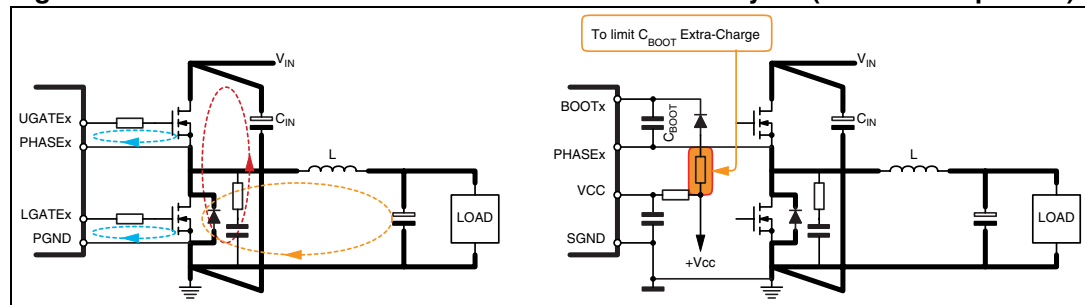

Note: *Boot capacitor extra charge. Systems that do not use Schottky diodes might show big negative spikes on the phase pin. This spike can be limited as well as the positive spike but has an additional consequence: it causes the bootstrap capacitor to be over-charged. This extra-charge can cause, in the worst case condition of maximum input voltage and during particular transients, that boot-to-phase voltage overcomes the abs. max. ratings also causing device failures. It is then suggested in this cases to limit this extra-charge by adding a small resistor in series to the boot diode (one resistor can be enough for all the three diodes if placed upstream the diode anode, see *Figure 30*) and by using standard and low-capacitive diodes.*

Use proper VIAs number when power traces have to move between different planes on the PCB in order to reduce both parasitic resistance and inductance. Moreover, reproducing the

same high-current trace on more than one PCB layer will reduce the parasitic resistance associated to that connection.

Connect output bulk capacitor as near as possible to the load, minimizing parasitic inductance and resistance associated to the copper trace also adding extra decoupling capacitors along the way to the load when this results in being far from the bulk capacitor bank.

Gate traces must be sized according to the driver RMS current delivered to the power MOSFET. The device robustness allows managing applications with the power section far from the controller without losing performances. External gate resistors help the device to dissipate power resulting in a general cooling of the device. When driving multiple MOSFETs in parallel, it is suggested to use one resistor for each MOSFET.

Device exposed pad is the power ground pin (LS drivers return path) as a consequence it has be tied to ground plane layer trough the lowest impedance connection. Connect it to the power ground plane using 5.2 x 5.2 mm square area on the PCB and with sixteen vias (uniformly distributed) to improve electrical and thermal conductivity, as shown in the [Figure 31](#).

Figure 31. Exposed pad VIAs number/location to ground plane

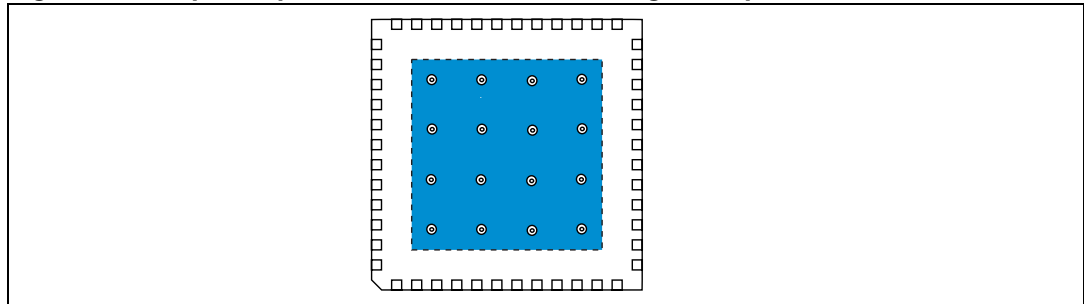

24.2 Small signal components and connections

These are small signal components and connections to critical nodes of the application as well as bypass capacitors for the device supply (see [Figure 30](#)). Locate the bypass capacitor (VCC and Bootstrap capacitor) close to the device and refer sensible components such as frequency set-up resistor R_{OSC} , overcurrent resistor R_{OCSET} . Star grounding is suggested: connect SGND to PGND plane in a single point to avoid that drops due to the high current delivered causes errors in the device behavior.

Remote sensing connection must be routed as parallel nets from the FBG/VSEN pins to the load in order to avoid the pick-up of any common mode noise. Connecting these pins in points far from the load will cause a non-optimum load regulation, increasing output tolerance.

Locate current reading components close to the device. The PCB traces connecting the reading point must use dedicated nets, routed as parallel traces in order to avoid the pick-up of any common mode noise. It's also important to avoid any offset in the measurement and, to get a better precision, to connect the traces as close as possible to the sensing elements. Small filtering capacitor can be added, near the controller, between V_{OUT} and SGND, on the CSx- line to allow higher layout flexibility.

25 Embedding L6716 - based VR

When embedding the VRD into the application, additional care must be taken since the whole VRD is a switching DC/DC regulator and the most common system in which it has to work is a digital system such as MB or similar. In fact, latest MB has become faster and powerful: high speed data bus are more and more common and switching-induced noise produced by the VRD can affect data integrity if not following additional layout guidelines. Few easy points must be considered mainly when routing traces in which high switching currents flow (high switching currents cause voltage spikes across the stray inductance of the trace causing noise that can affect the near traces):

Keep safe guarding distance between high current switching VRD traces and data buses, especially if high-speed data bus to minimize noise coupling.

Keep safe guard distance or filter properly when routing bias traces for I/O sub-systems that must walk near the VRD.

Possible causes of noise can be located in the PHASE connections, MOSFET gate drive and Input voltage path (from input bulk capacitors and HS drain). Also PGND connections must be considered if not insisting on a power ground plane. These connections must be carefully kept far away from noise-sensitive data bus.

Since the generated noise is mainly due to the switching activity of the VRM, noise emissions depend on how fast the current switches. To reduce noise emission levels, it is also possible, in addition to the previous guidelines, to reduce the current slope by properly tuning the HS gate resistor and the PHASE snubber network.

26 Package mechanical data

In order to meet environmental requirements, ST offers these devices in different grades of ECOPACK® packages, depending on their level of environmental compliance. ECOPACK® specifications, grade definitions and product status are available at: www.st.com. ECOPACK is an ST trademark.

Figure 32. VFQFPN-48 mechanical data and package dimensions

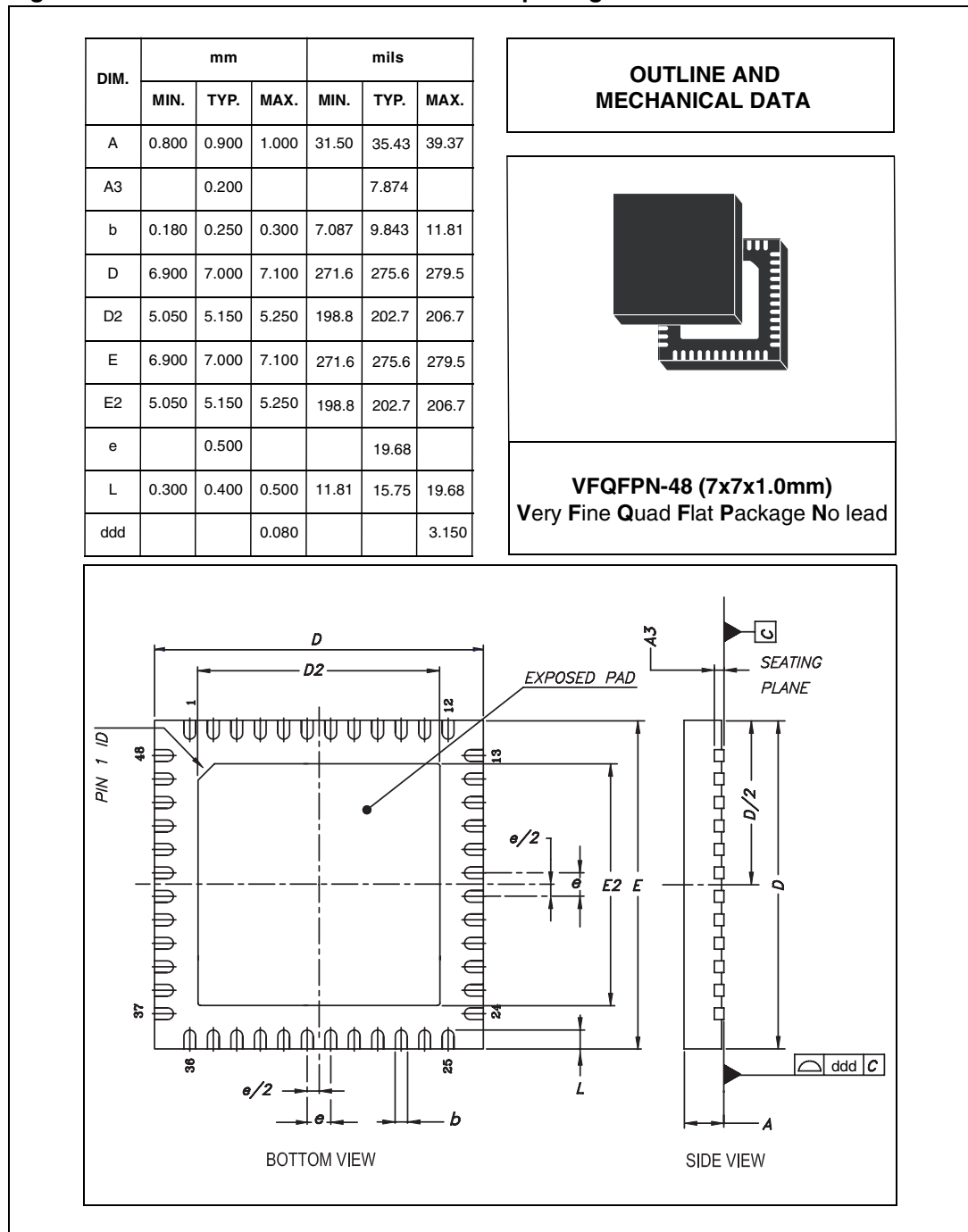

27 Revision history

Table 12. Document revision history

Date	Revision	Changes
28-May-2009	1	First release
12-Aug-2009	2	Updated <i>Table 3 on page 13</i> .
20-Jan-2010	3	Updated <i>Table 2 on page 8, Table 3 on page 13, Chapter 13 on page 29, Figure 14 on page 29 and Chapter 20 on page 45</i>

Please Read Carefully:

Information in this document is provided solely in connection with ST products. STMicroelectronics NV and its subsidiaries ("ST") reserve the right to make changes, corrections, modifications or improvements, to this document, and the products and services described herein at any time, without notice.

All ST products are sold pursuant to ST's terms and conditions of sale.

Purchasers are solely responsible for the choice, selection and use of the ST products and services described herein, and ST assumes no liability whatsoever relating to the choice, selection or use of the ST products and services described herein.

No license, express or implied, by estoppel or otherwise, to any intellectual property rights is granted under this document. If any part of this document refers to any third party products or services it shall not be deemed a license grant by ST for the use of such third party products or services, or any intellectual property contained therein or considered as a warranty covering the use in any manner whatsoever of such third party products or services or any intellectual property contained therein.

UNLESS OTHERWISE SET FORTH IN ST'S TERMS AND CONDITIONS OF SALE ST DISCLAIMS ANY EXPRESS OR IMPLIED WARRANTY WITH RESPECT TO THE USE AND/OR SALE OF ST PRODUCTS INCLUDING WITHOUT LIMITATION IMPLIED WARRANTIES OF MERCHANTABILITY, FITNESS FOR A PARTICULAR PURPOSE (AND THEIR EQUIVALENTS UNDER THE LAWS OF ANY JURISDICTION), OR INFRINGEMENT OF ANY PATENT, COPYRIGHT OR OTHER INTELLECTUAL PROPERTY RIGHT.

UNLESS EXPRESSLY APPROVED IN WRITING BY AN AUTHORIZED ST REPRESENTATIVE, ST PRODUCTS ARE NOT RECOMMENDED, AUTHORIZED OR WARRANTED FOR USE IN MILITARY, AIR CRAFT, SPACE, LIFE SAVING, OR LIFE SUSTAINING APPLICATIONS, NOR IN PRODUCTS OR SYSTEMS WHERE FAILURE OR MALFUNCTION MAY RESULT IN PERSONAL INJURY, DEATH, OR SEVERE PROPERTY OR ENVIRONMENTAL DAMAGE. ST PRODUCTS WHICH ARE NOT SPECIFIED AS "AUTOMOTIVE GRADE" MAY ONLY BE USED IN AUTOMOTIVE APPLICATIONS AT USER'S OWN RISK.

Resale of ST products with provisions different from the statements and/or technical features set forth in this document shall immediately void any warranty granted by ST for the ST product or service described herein and shall not create or extend in any manner whatsoever, any liability of ST.

ST and the ST logo are trademarks or registered trademarks of ST in various countries.

Information in this document supersedes and replaces all information previously supplied.

The ST logo is a registered trademark of STMicroelectronics. All other names are the property of their respective owners.

© 2010 STMicroelectronics - All rights reserved



STMicroelectronics group of companies

Australia - Belgium - Brazil - Canada - China - Czech Republic - Finland - France - Germany - Hong Kong - India - Israel - Italy - Japan - Malaysia - Malta - Morocco - Philippines - Singapore - Spain - Sweden - Switzerland - United Kingdom - United States of America





www.st.com

Looking for pricing, stock, or lifecycle information?

Click below to explore more details on WIN SOURCE:

-  [View L6716TR on WIN SOURCE](#)
-  [STMicroelectronics](#) Information

Optimize Your Supply Chain with WIN SOURCE Solutions

-  Global Sourcing Solution
-  Obsolete Management
-  Cost Control Management
-  Shortage Management
-  Alternative Solution
-  Excess Inventory Management