



THE DATASHEET OF L9951XP



Rear door actuator driver

Features

Type	Outputs ⁽¹⁾	R _{on} ⁽²⁾	I _{OUT}	V _S
L9951 L9951XP	OUT1	150 mΩ	7.4 A	28 V
	OUT2	200 mΩ	5 A	
	OUT3	200 mΩ	5 A	
	OUT4	800 mΩ	1.25 A	
	OUT5	800 mΩ	1.25 A	

1. See block diagram.

2. Typical values.

- One half bridge for 7.4 A load (R_{on} = 150 mΩ)
- Two half bridges for 5 A load (R_{on} = 200 mΩ)
- Two highside drivers for 1.25 A load (R_{on} = 800 mΩ)
- Programmable softstart function to drive loads with higher inrush currents (i.e. current > 7.4A, >5A, >1.25A)
- Very low current consumption in standby mode (I_S < 3μA, typ. T_j ≤ 85°C)
- All outputs short circuit protected
- Current monitor output for all highside drivers
- All outputs over temperature protected
- Open-load diagnostic for all outputs
- Overload diagnostic for all outputs
- Programmable PWM control of all outputs
- Charge pump output for reverse polarity protection

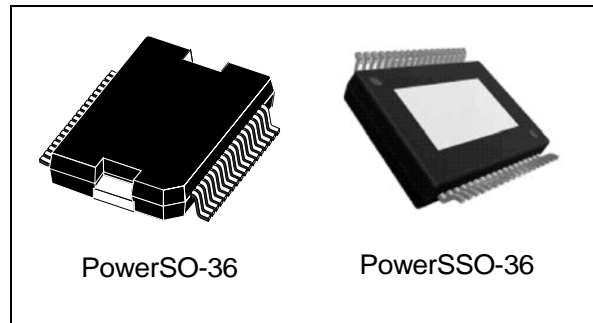

Applications

- Rear door actuator driver with bridges for door lock and safe lock and two 5W or 10W - light bulbs.

Description

The L9951 and L9951XP are microcontroller driven, multifunctional rear door actuator drivers for automotive applications. Up to two DC motors and two grounded resistive loads can be driven with three half bridges and two high side drivers. The integrated standard serial peripheral interface (SPI) controls all operation modes (forward, reverse, brake and high impedance). All diagnostic information is available via the SPI.

Table 1. Device summary

Package	Order codes	
	Tube	Tape and reel
PowerSO-36	L9951	L9951TR
PowerSSO-36	L9951XP	L9951XPTR

Contents

1	Block diagram and pin description	6
2	Electrical specifications	9
2.1	Absolute maximum ratings	9
2.2	ESD protection	9
2.3	Thermal data	9
2.4	Temperature warning and thermal shutdown	10
2.5	Electrical characteristics	10
2.6	SPI - electrical characteristics	14
3	Application information	19
3.1	Dual power supply: VS and VCC	19
3.2	Standby - mode	19
3.3	Inductive loads	19
3.4	Diagnostic functions	19
3.5	Over-voltage and under-voltage detection	20
3.6	Temperature warning and thermal shutdown	20
3.7	Open-load detection	20
3.8	Over load detection	20
3.9	Current monitor	20
3.10	PWM input	21
3.11	Cross-current protection	21
3.12	Programmable softstart function to drive loads with higher inrush current	21
4	Functional description of the SPI	22
4.1	Serial Peripheral Interface (SPI)	22
4.2	Chip Select Not (CSN)	22
4.3	Serial Data In (DI)	22
4.4	Serial Data Out (DO)	23
4.5	Serial clock (CLK)	23
4.6	Input data register	23
4.7	Status register	23

4.8	Test mode	23
5	Packages thermal data	28
6	Package and packing information	29
6.1	ECOPACK [®] packages	29
6.2	PowerSO-36 [™] package information	29
6.3	PowerSSO-36 [™] package information	31
6.4	PowerSO-36 [™] packing information	32
6.5	PowerSSO-36 [™] packing information	34
7	Revision history	35

List of tables

Table 1.	Device summary	1
Table 2.	Pin definitions and functions	7
Table 3.	Absolute maximum ratings	9
Table 4.	ESD protection	9
Table 5.	Thermal data	9
Table 6.	Temperature warning and thermal shutdown	10
Table 7.	Supply	10
Table 8.	Overvoltage and undervoltage detection	11
Table 9.	Current monitor output	11
Table 10.	Charge pump output	12
Table 11.	OUT 1 - OUT 5	12
Table 12.	Delay time from standby to active mode	14
Table 13.	Inputs: CSN, CLK, PWM1/2 and DI	14
Table 14.	DI timing	14
Table 15.	DO	15
Table 16.	DO timing	15
Table 17.	EN, CSN timing	16
Table 18.	Test mode	24
Table 19.	SPI - Input data and status register 0	24
Table 20.	SPI - Input data and status register 1	26
Table 21.	PowerSO-36™ mechanical data	29
Table 22.	PowerSSO-36™ mechanical data	31
Table 23.	Document revision history	35

List of figures

Figure 1.	Block diagram	6
Figure 2.	Configuration diagram (top view)	8
Figure 3.	SPI - transfer timing diagram	16
Figure 4.	SPI - input timing	16
Figure 5.	SPI - DO valid data delay time and valid time	17
Figure 6.	SPI - DO enable and disable time	17
Figure 7.	SPI - driver turn-on/off timing, minimum CSN HI time	18
Figure 8.	SPI - timing of status bit 0 (fault condition)	18
Figure 9.	Example of programmable softstart function for inductive loads	21
Figure 10.	Packages thermal data	28
Figure 11.	PowerSO-36™ package dimensions	29
Figure 12.	PowerSSO-36™ package dimensions	31
Figure 13.	PowerSO-36™ tube shipment (no suffix)	32
Figure 14.	PowerSO-36™ tape and reel shipment (suffix "TR")	33
Figure 15.	PowerSSO-36™ tube shipment (no suffix)	34
Figure 16.	PowerSSO-36™ tape and reel shipment (suffix "TR")	34

1 Block diagram and pin description

Figure 1. Block diagram

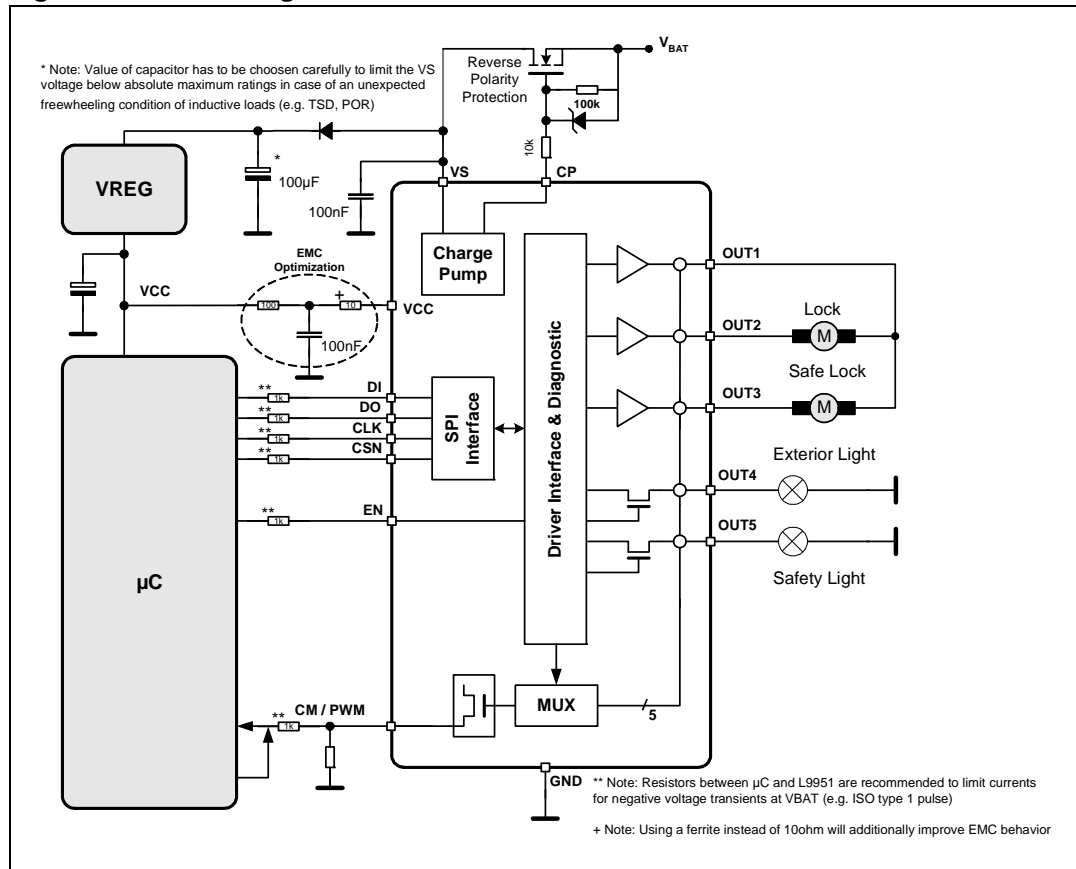

Table 2. Pin definitions and functions

Pin	Symbol	Function
1, 18, 19, 36	GND	Ground . Reference potential. Note: For the capability of driving the full current at the outputs all pins of GND must be externally connected.
6, 7, 14, 15, 23, 24, 29, 32	VS	Power supply voltage (external reverse protection required). For EMI reason a ceramic capacitor as close as possible to GND is recommended. Note: for the capability of driving the full current at the outputs all pins of VS must be externally connected.
3, 4, 34	OUT1	Half-bridge output 1. The output is built by a high side and a low side switch, which are internally connected. The output stage of both switches is a power DMOS transistor. Each driver has an internal reverse diode (bulk-drain-diode: high side driver from output to VS, low side driver from GND to output). This output is over-current and open-load protected. Note: for the capability of driving the full current at the outputs all pins of OUT1 must be externally connected.
8	DI	Serial data input. The input requires CMOS logic levels and receives serial data from the microcontroller. The data is a 16bit control word and the least significant bit (LSB, bit 0) is transferred first.
9	CM/PWM	Current monitor output/PWM input. Depending on the selected multiplexer bits (bit 9, 10, 11) of Input Data Register this output sources an image of the instant current through the corresponding high side driver with a ratio of 1/10.000. This pin is bidirectional. The microcontroller can overwrite the current monitor signal to provide a PWM input for all outputs. Testmode: If CSN is raised above 7.5V the device will enter the test mode. In test mode this output can be used to measure some internal signals (see Table 18).
10	CSN	Chip select not input / Testmode . This input is low active and requires CMOS logic levels. The serial data transfer between L9951 and micro controller is enabled by pulling the input CSN to low level. If an input voltage of more than 7.5V is applied to CSN pin the L9951 will be switched into a test mode.
11	DO	Serial data output . The diagnosis data is available via the SPI and this tristate-output. The output will remain in tristate, if the chip is not selected by the input CSN (CSN = high).
12	VCC	Logic supply voltage . For this input a ceramic capacitor as close as possible to GND is recommended.
13	CLK	Serial clock input . This input controls the internal shift register of the SPI and requires CMOS logic levels.

Table 2. Pin definitions and functions (continued)

Pin	Symbol	Function
16, 17	OUT2	Half-bridge output 2 (see OUT1 - pin 3, 4). Note: for the capability of driving the full current at the outputs all pins of OUT2 must be externally connected.
20, 21	OUT3	Half-bridge output 3 (see OUT1 - pin 3, 4). Note: for the capability of driving the full current at the outputs all pins of OUT3 must be externally connected.
26	CP	Charge Pump Output . This output is provided to drive the gate of an external n-channel power MOS used for reverse polarity protection (see Figure 1).
27	EN	Enable input. If Enable input is forced to GND the device will enter Standby-Mode. The outputs will be switched off and all registers will be cleared
33, 35	OUT4, OUT5	High side driver output 4, 5 . The output is built by a high side switch and is intended for resistive loads, hence the internal reverse diode from GND to the output is missing. For ESD reason a diode to GND is present but the energy which can be dissipated is limited. The high side driver is a power DMOS transistor with an internal reverse diode from the output to VS (bulk-drain-diode). The output is over-current and open-load protected.

Figure 2. Configuration diagram (top view)

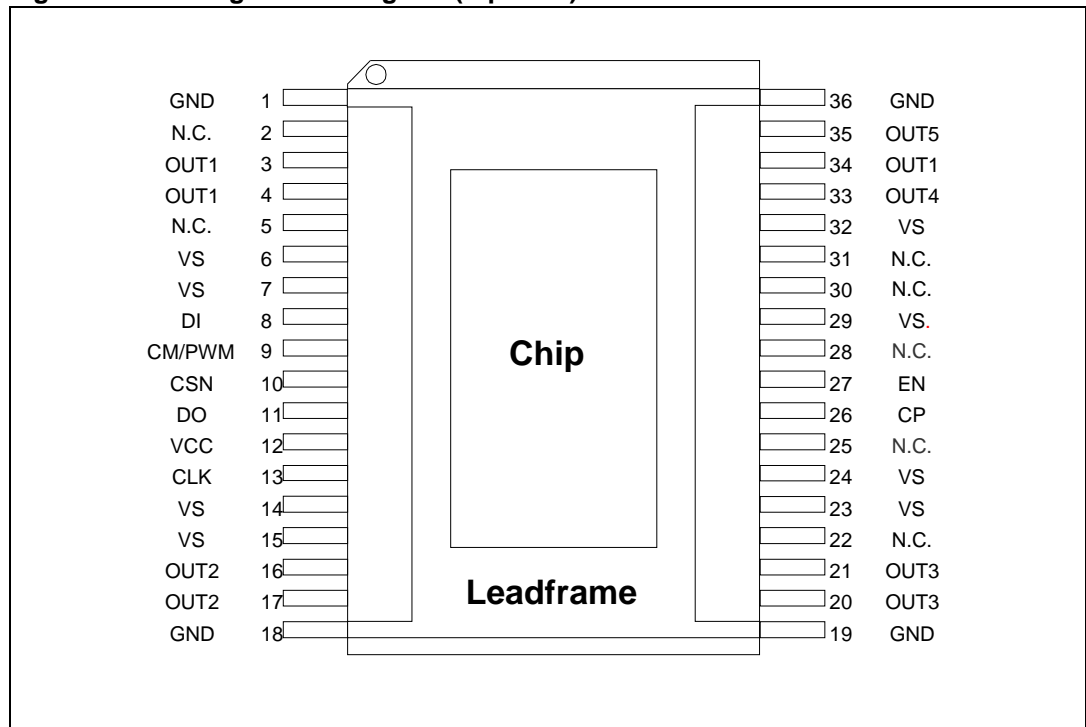

2 Electrical specifications

2.1 Absolute maximum ratings

Stressing the device above the rating listed in the “Absolute maximum ratings” table may cause permanent damage to the device. These are stress ratings only and operation of the device at these or any other conditions above those indicated in the operating sections of this specification is not implied. Exposure to absolute maximum rating conditions for extended periods may affect device reliability. Refer also to the STMicroelectronics sure program and other relevant quality document

Table 3. Absolute maximum ratings

Symbol	Parameter	Value	Unit
V_S	DC supply voltage	-0.3 to 28	V
	Single pulse $t_{max} < 400ms$	40	V
V_{CC}	Stabilized supply voltage, logic supply	-0.3 to 5.5	V
$V_{DI}, V_{DO}, V_{CLK}, V_{CSN}, V_{EN}$	Digital input / output voltage	-0.3 to $V_{CC} + 0.3$	V
V_{CM}	Current monitor output	-0.3 to $V_{CC} + 0.3$	V
V_{CP}	Charge pump output	-25 to $V_S + 11$	V
$I_{OUT1,2,3}$	Output current	± 10	A
$I_{OUT4,5}$	Output current	± 5	A

2.2 ESD protection

Table 4. ESD protection

Parameter	Value	Unit
All pins	$\pm 4^{(1)}$	kV
Output pins: OUT1 - OUT5	$\pm 8^{(2)}$	kV

1. HBM according to CDF-AEC-Q100-002.

2. HBM with all unzapped pins grounded.

2.3 Thermal data

Table 5. Thermal data

Symbol	Parameter	Value	Unit
T_j	Operating junction temperature	-40 to 150	°C

2.4 Temperature warning and thermal shutdown

Table 6. Temperature warning and thermal shutdown

Symbol	Parameter	Min.	Typ.	Max.	Unit
$T_{jTW\ ON}$	Temperature warning threshold junction temperature			150	°C
$T_{jTW\ OFF}$	Temperature warning threshold junction temperature	130			°C
$T_{jTW\ HYS}$	Temperature warning hysteresis		5		°K
$T_{jSD\ ON}$	Thermal shutdown threshold junction temperature			170	°C
$T_{jSD\ OFF}$	Thermal shutdown threshold junction temperature	150			°C
$T_{jSD\ HYS}$	Thermal shutdown hysteresis		5		°K

2.5 Electrical characteristics

$V_S = 8$ to 16 V, $V_{CC} = 4.5$ to 5.3 V, $T_j = -40$ to 150 °C, unless otherwise specified.

The voltages are referred to GND and currents are assumed positive, when the current flows into the pin.

Table 7. Supply

Symbol	Parameter	Test condition	Min.	Typ.	Max.	Unit
V_S	Operating supply voltage range		7		28	V
I_S	V_S DC supply current	$V_S = 13V$, $V_{CC} = 5.0V$ active mode OUT1 - OUT5 floating		7	20	mA
	V_S quiescent supply current	$V_S = 13V$, $V_{CC} = 0V$ standby mode OUT1 - OUT5 floating $T_{test} = -40^\circ C, 25^\circ C$		3	10	μA
		$T_{test} = 130^\circ C$			6	20

Table 7. Supply (continued)

Symbol	Parameter	Test condition	Min.	Typ.	Max.	Unit
I_{CC}	V_{CC} DC supply current	$V_S = 13V, V_{CC} = 5.0V$ CSN = V_{CC} active mode		1	3	mA
	V_{CC} quiescent supply current	$V_S = 13V, V_{CC} = 5.0V$ CSN = V_{CC} standby mode OUT1 - OUT5 floating		1	3	μA
$I_S + I_{CC}$	Sum quiescent supply current	$V_S = 13V, V_{CC} = 5.0V$ CSN = V_{CC} standby mode OUT1 - OUT5 floating		7	23	μA

Table 8. Overvoltage and undervoltage detection

Symbol	Parameter	Test condition	Min.	Typ.	Max.	Unit
$V_{SUV\ ON}$	VS UV-threshold voltage	V_S increasing	6.0		7.2	V
$V_{SUV\ OFF}$	VS UV-threshold voltage	V_S decreasing	5.4		6.5	V
$V_{SUV\ hyst}$	VS UV-hysteresis	$V_{SUV\ ON} - V_{SUV\ OFF}$		0.55		V
$V_{SOV\ OFF}$	VS OV-threshold voltage	V_S increasing	18		24.5	V
$V_{SOV\ ON}$	VS OV-threshold voltage	V_S decreasing	17.5			V
$V_{SOV\ hyst}$	VS OV-hysteresis	$V_{SOV\ OFF} - V_{SOV\ ON}$		0.5		V
$V_{POR\ OFF}$	Power-on-reset threshold	V_{CC} increasing			4.4	V
$V_{POR\ ON}$	Power-on-reset threshold	V_{CC} decreasing	3.1			V
$V_{POR\ hyst}$	Power-on-reset hysteresis	$V_{POR\ OFF} - V_{POR\ ON}$		0.3		V

Table 9. Current monitor output

Symbol	Parameter	Test condition	Min.	Typ.	Max.	Unit
V_{CM}	Functional voltage range	$V_{CC} = 5V$	0		4	V
$I_{CM,r}$	Current monitor output ratio: $I_{CM} / I_{OUT1,2,3,4,5}$	$0V \leq V_{CM} \leq 4V, V_{CC}=5V$		1:10000		-
$I_{CM\ acc}$	Current monitor accuracy	$0V \leq V_{CM} \leq 4V,$ $V_{CC}=5V,$ $I_{OUT1-5,low} = 500mA$ $I_{OUT1,high} = 6A$ $I_{OUT2,3,high} = 4.9A$ $I_{OUT4,5,high} = 1.2A$ (FS=full scale=600 μA)		4% + 1%FS	8% + 2%FS	-

Table 10. Charge pump output

Symbol	Parameter	Test condition	Min.	Typ.	Max.	Unit
V_{CP}	Charge pump output voltage	$V_S=8V, I_{CP} = -60\mu A$	6		13	V
		$V_S=10V, I_{CP} = -80\mu A$	8		13	V
		$V_S\geq 12V, I_{CP} = -100\mu A$	10		13	V
I_{CP}	Charge pump output current	$V_{CP} = V_S+10V$ $V_S = 13.5V$	100	150	300	μA

Table 11. OUT 1 - OUT 5

Symbol	Parameter	Test condition	Min.	Typ.	Max.	Unit
$R_{ON\ OUT1}$	On-resistance to supply or GND	$V_S = 13.5 V, T_J = 25\ ^\circ C,$ $I_{OUT1} = \pm 3 A$		150	200	m Ω
		$V_S = 13.5 V, T_J = 125\ ^\circ C,$ $I_{OUT1} = \pm 3 A$		225	300	m Ω
		$V_S = 8.0 V, T_J = 25\ ^\circ C,$ $I_{OUT1} = \pm 3 A$		150	200	m Ω
$R_{ON\ OUT2}$ $R_{ON\ OUT3}$	On-resistance to supply or GND	$V_S = 13.5 V, T_J = 25\ ^\circ C,$ $I_{OUT2,3} = \pm 3 A$		200	270	m Ω
		$V_S = 13.5 V, T_J = 125\ ^\circ C,$ $I_{OUT2,3} = \pm 3 A$		300	400	m Ω
		$V_S = 8.0 V, T_J = 25\ ^\circ C,$ $I_{OUT2,3} = \pm 3 A$		200	270	m Ω
$r_{ON\ OUT4},$ $r_{ON\ OUT5}$	On-resistance to supply or GND	$V_S = 13.5 V, T_J = 25\ ^\circ C,$ $I_{OUT4,5} = \pm 0.8 A$		800	1100	m Ω
		$V_S = 13.5 V, T_J = 125\ ^\circ C,$ $I_{OUT4,5} = \pm 0.8 A$		1250	1700	m Ω
		$V_S = 8.0 V, T_J = 25\ ^\circ C,$ $I_{OUT4,5} = \pm 0.8 A$		800	1100	m Ω
$ I_{OUT1} $	Output current limitation to supply or GND	Sink and source	7.4		15.5	A
$ I_{OUT2} ,$ $ I_{OUT3} $	Output current limitation to supply or GND	Sink and source	5.0		10.5	A
$ I_{OUT4} ,$ $ I_{OUT5} $	Output current limitation to GND	Source	1.25		2.6	A
$t_{d\ ON\ H}$	Output delay time, highside driver on	$V_S = 13.5 V,$ corresponding lowside driver is not active	20	40	90	μs
$t_{d\ OFF\ H}$	Output delay time, highside driver off	$V_S = 13.5 V$	80	200	300	μs
$t_{d\ ON\ L}$	Output delay time, lowside driver on	$V_S = 13.5 V,$ corresponding highside driver is not active	20	60	80	μs

Table 11. OUT 1 - OUT 5 (continued)

Symbol	Parameter	Test condition	Min.	Typ.	Max.	Unit
$t_{d\ OFF\ L}$	Output delay time, lowside driver off	$V_S = 13.5\ V$	80	150	300	μs
$t_{D\ HL}$	Cross current protection time, source to sink	$t_{d\ ON\ L} - t_{d\ OFF\ H,}$		200	400	μs
$t_{D\ LH}$	Cross current protection time, sink to source	$t_{d\ ON\ H} - t_{d\ OFF\ L}$		200	400	μs
I_{QLH}	Switched-off output current highside drivers of OUT1-5	$V_{OUT1-5} = 0V$, standby mode	0	-2	-5	μA
		$V_{OUT1-5} = 0V$, active mode	-40	-15	0	μA
I_{QLL}	Switched-off output current lowside drivers of OUT1-3	$V_{OUT1-3} = V_S$, standby mode	0	50	100	μA
		$V_{OUT1-3} = V_S$, active mode	-40	-15	0	μA
I_{OLD1}	Open-load detection current of OUT1		70	160	240	mA
I_{OLD23}	Open-load detection current of OUT2, OUT3		70	160	240	mA
I_{OLD45}	Open-load detection current of OUT4 and OUT5		5	15	40	mA
t_{dOL}	Minimum duration of open-load condition to set the status bit		500		3000	μs
t_{ISC}	Minimum duration of over-current condition to switch off the driver		10		100	μs
dV_{OUT1}/dt	Slew rate of OUT1	$V_S = 13.5\ V$ $I_{load} = \pm 1.5\ A$	0.1	0.2	0.4	$V/\mu s$
dV_{OUT23}/dt	Slew rate of OUT2, OUT3	$V_S = 13.5\ V$ $I_{load} = \pm 1.5\ A$	0.1	0.2	0.4	$V/\mu s$
dV_{OUT45}/dt	Slew rate of OUT4, OUT5	$V_S = 13.5\ V$ $I_{load} = -0.8\ A$	0.1	0.2	0.4	$V/\mu s$

2.6 SPI - electrical characteristics

($V_S = 8$ to 16 V, $V_{CC} = 4.5$ to 5.3 V, $T_j = -40$ to 150 °C, unless otherwise specified. The voltages are referred to GND and currents are assumed positive, when the current flows into the pin).

Table 12. Delay time from standby to active mode

Symbol	Parameter	Test condition	Min.	Typ.	Max.	Unit
t_{set}	Internal startup time	Switching from standby to active mode. Time until not Ready Bit goes low.		80	300	μ s

Table 13. Inputs: CSN, CLK, PWM1/2 and DI

Symbol	Parameter	Test condition	Min.	Typ.	Max.	Unit
V_{inL}	Input low level	$V_{CC} = 5V$	1.5	2.0		V
V_{inH}	Input high level	$V_{CC} = 5V$		3.0	3.5	V
V_{inHyst}	Input hysteresis	$V_{CC} = 5V$	0.5			V
$I_{CSN\ in}$	Pull up current at input CSN	$V_{CSN} = 3.5V$ $V_{CC} = 5V$	-50	-25	-10	μ A
$I_{CLK\ in}$	Pull down current at input CLK	$V_{CLK} = 1.5V$	10	25	50	μ A
$I_{DI\ in}$	Pull down current at input DI	$V_{DI} = 1.5V$	10	25	50	μ A
$I_{EN\ in}$	Pull down resistance at input EN		100	210	480	k Ω
C_{in}	Input capacitance at input CLK, DI and PWM	$V_{CC} = 0$ to $5.3V$		10	15	pF

Note: Value of input capacity is not measured in production test. Parameter guaranteed by design.

Table 14. DI timing⁽¹⁾

Symbol	Parameter	Test condition	Min.	Typ.	Max.	Unit
t_{CLK}	Clock period	$V_{CC} = 5V$	1000			ns
t_{CLKH}	Clock high time	$V_{CC} = 5V$	400			ns
t_{CLKL}	Clock low time	$V_{CC} = 5V$	400			ns
$t_{set\ CSN}$	CSN setup time, CSN low before rising edge of CLK	$V_{CC} = 5V$	400			ns
$t_{set\ CLK}$	CLK setup time, CLK high before rising edge of CSN	$V_{CC} = 5V$	400			ns
$t_{set\ DI}$	DI setup time	$V_{CC} = 5V$	200			ns
$t_{hold\ time}$	DI hold time	$V_{CC} = 5V$	200			ns

Table 14. DI timing⁽¹⁾ (continued)

Symbol	Parameter	Test condition	Min.	Typ.	Max.	Unit
$t_{r\ in}$	Rise time of input signal DI, CLK, CSN	$V_{CC} = 5V$			100	ns
$t_{f\ in}$	Fall time of input signal DI, CLK, CSN	$V_{CC} = 5V$			100	ns

1. See [Figure 3](#) and [Figure 4](#)

Note: *DI timing parameters tested in production by a passed/failed test:*
 $T_j = -40^{\circ}C/+25^{\circ}C$: SPI communication @2MHZ.
 $T_j = +125^{\circ}C$: SPI communication @1.25MHZ.

Table 15. DO

Symbol	Parameter	Test condition	Min.	Typ.	Max.	Unit
V_{DOL}	Output low level	$V_{CC} = 5V, I_D = -4mA$		0.2	0.4	V
V_{DOH}	Output high level	$V_{CC} = 5V, I_D = 4mA$	$V_{CC} - 0.4$	$V_{CC} - 0.2$		V
I_{DOLK}	Tristate leakage current	$V_{CSN} = V_{CC}, 0V < V_{DO} < V_{CC}$	-10		10	μA
$C_{DO}^{(1)}$	Tristate input capacitance	$V_{CSN} = V_{CC}, 0V < V_{CC} < 5.3V$		10	15	pF

1. Value of input capacity is not measured in production test. Parameter guaranteed by design.

Table 16. DO timing⁽¹⁾

Symbol	Parameter	Test condition	Min.	Typ.	Max.	Unit
$t_{r\ DO}$	DO rise time	$C_L = 100\ pF, I_{load} = -1mA$		80	140	ns
$t_{f\ DO}$	DO fall time	$C_L = 100\ pF, I_{load} = 1mA$		50	100	ns
$t_{en\ DO\ tri\ L}$	DO enable time from tristate to low level	$C_L = 100\ pF, I_{load} = 1mA$ pull-up load to V_{CC}		100	250	ns
$t_{dis\ DO\ L\ tri}$	DO disable time from low level to tristate	$C_L = 100\ pF, I_{load} = 4mA$ pull-up load to V_{CC}		380	450	ns
$t_{en\ DO\ tri\ H}$	DO enable time from tristate to high level	$C_L = 100\ pF, I_{load} = -1mA$ pull-down load to GND		100	250	ns
$t_{dis\ DO\ H\ tri}$	DO disable time from high level to tristate	$C_L = 100\ pF, I_{load} = -4mA$ pull-down load to GND		380	450	ns
$t_{d\ DO}$	DO delay time	$V_{DO} < 0.3V_{CC}, V_{DO} > 0.7V_{CC}, C_L = 100pF$		50	250	ns

1. See [Figure 5](#) and [Figure 6](#).

Table 17. EN, CSN timing⁽¹⁾

Symbol	Parameter	Test condition	Min.	Typ.	Max.	Unit
$t_{EN_CSN_LO}$	Minimum EN high before sending first SPI frame, i.e. CSN going low	Transfer of SPI-command to input register		20	50	μs
$t_{CSN_HI,min}$	Minimum CSN HI time between two SPI frames	Transfer of SPI-command to input register		2	4	μs

1. See [Figure 7](#)

Figure 3. SPI - transfer timing diagram

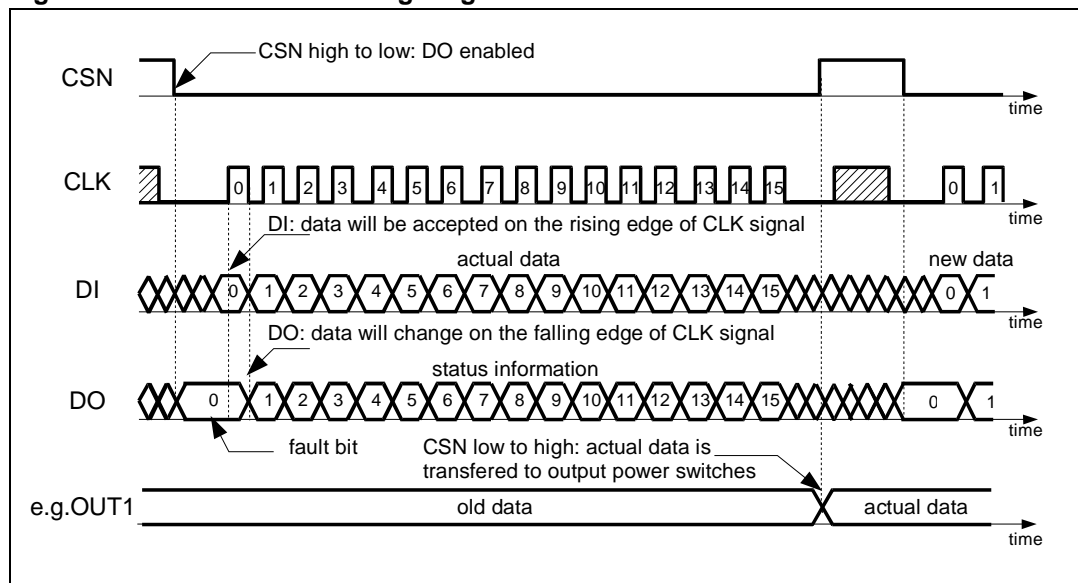

Figure 4. SPI - input timing

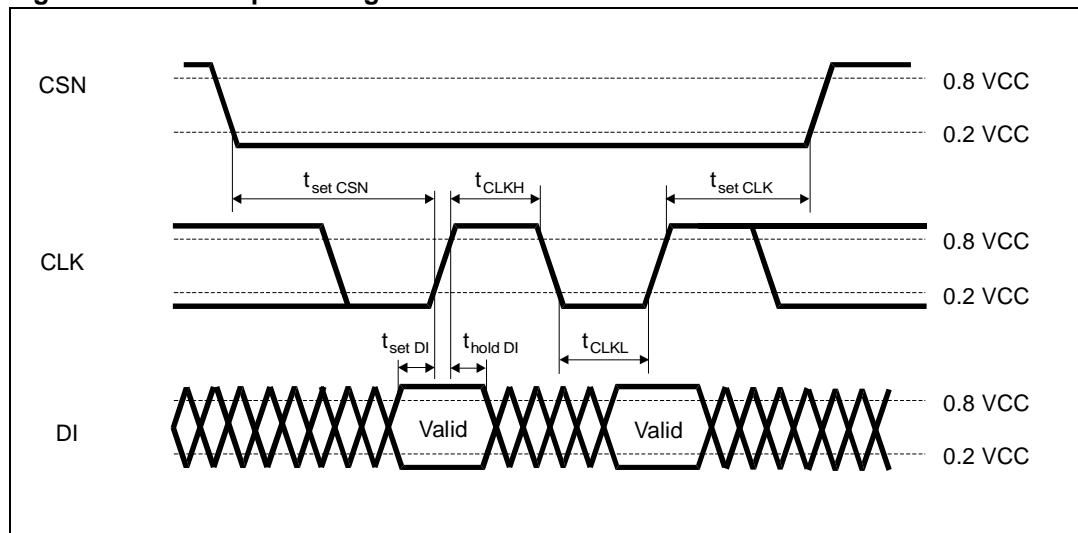

Figure 5. SPI - DO valid data delay time and valid time

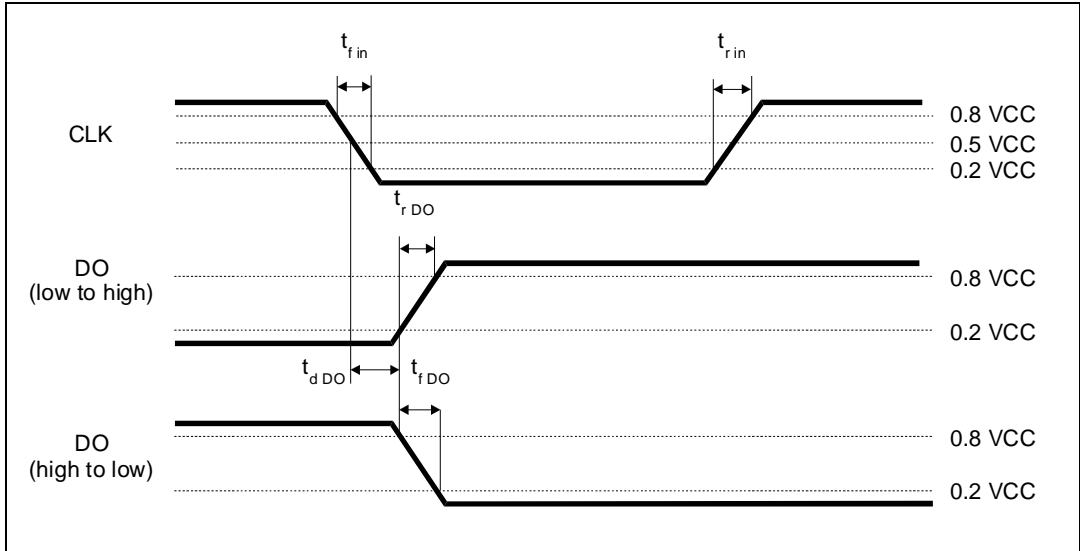

Figure 6. SPI - DO enable and disable time

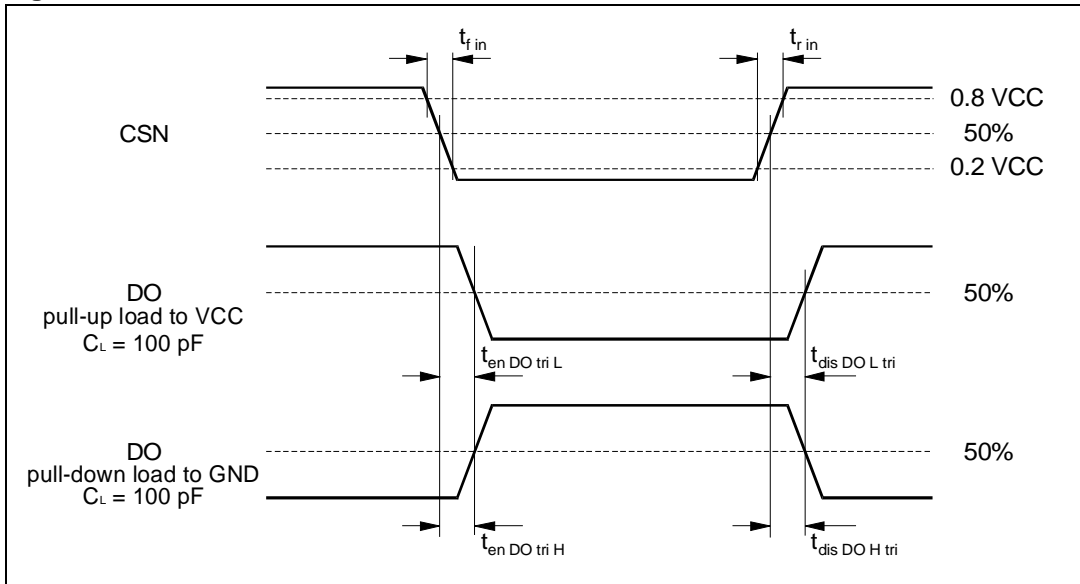

Figure 7. SPI - driver turn-on/off timing, minimum CSN HI time

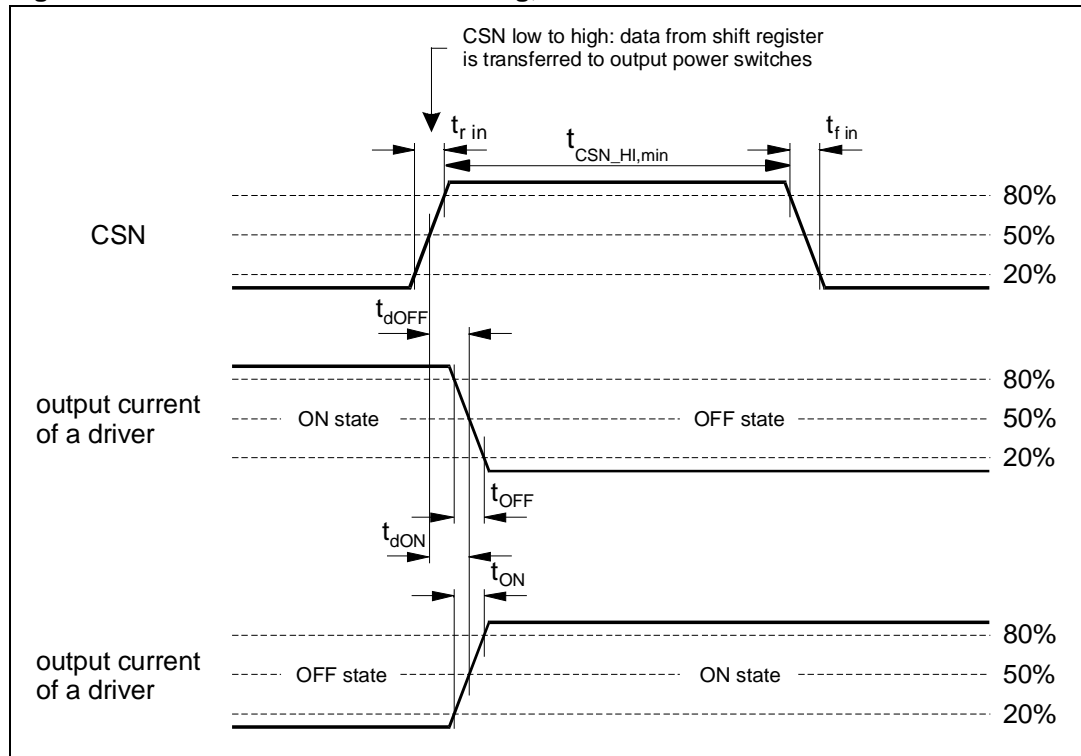
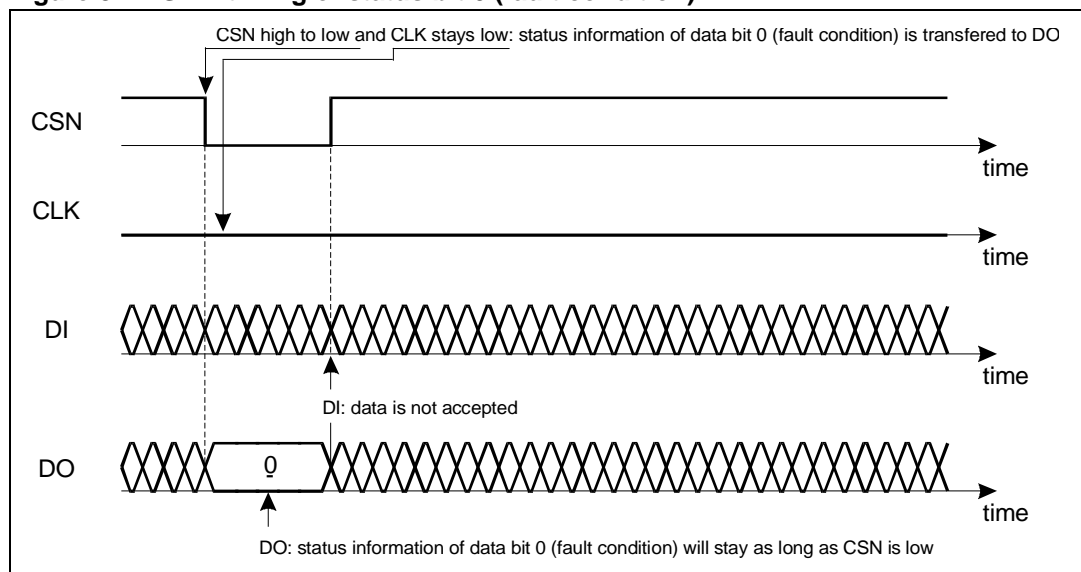

Figure 8. SPI - timing of status bit 0 (fault condition)



3 Application information

3.1 Dual power supply: V_S and V_{CC}

The power supply voltage V_S supplies the half bridges and the high side drivers. An internal charge-pump is used to drive the high side switches. The logic supply voltage V_{CC} (stabilized 5V) is used for the logic part and the SPI of the device. Due to the independent logic supply voltage the control and status information will not be lost, if there are temporary spikes or glitches on the power supply voltage. In case of power-on (V_{CC} increases from under voltage to $V_{POR\ OFF} = 4.0V$, typical) the circuit is initialized by an internally generated power-on-reset (POR).

If the voltage V_{CC} decreases under the minimum threshold ($V_{POR\ ON} = 3.6V$, typical), the outputs are switched to tristate (high impedance) and the status registers are cleared.

3.2 Standby - mode

The standby mode of the L9951 is activated by switching the EN input do GND. All latched data will be cleared and the inputs and outputs are switched to high impedance. In the standby mode the current at V_S (V_{CC}) is less than 3 μA (1 μA) for CSN = high (DO in tristate). If EN is switched to 5V the device will enter the active mode. In the active mode the charge-pump and the supervisor functions are activated.

3.3 Inductive loads

Each half bridge is built by an internally connected high side and a low side power DMOS transistor. Due to the built-in reverse diodes of the output transistors, inductive loads can be driven at the outputs OUT1 to OUT3 without external free-wheeling diodes. The high side drivers OUT4 to OUT5 are intended to drive resistive loads. Hence only a limited energy ($E < 0.5mJ$) can be dissipated by the internal ESD-diodes in freewheeling condition. For inductive loads ($L > 50\mu H$) an external free-wheeling diode connected to GND and the corresponding output is needed.

3.4 Diagnostic functions

All diagnostic functions (over/open-load, power supply over-/undervoltage, temperature warning and thermal shutdown) are internally filtered and the condition has to be valid for at least 32 μs (open-load: 1ms, respectively) before the corresponding status bit in the status registers will be set. The filters are used to improve the noise immunity of the device. Open-load and temperature warning function are intended for information purpose and will not change the state of the output drivers. On contrary, the over load and thermal shutdown condition will disable the corresponding driver (over load) or all drivers (thermal shutdown), respectively. Without setting the over-current recovery bit in the Input Data Register to logic high, the microcontroller has to clear the over-current status bit to reactivate the corresponding driver. Each driver has a corresponding over-current recovery bit. If this bit is set, the device will automatically switch-on the outputs again after a short recovery time. The duty cycle in over-current condition can be programmed by the SPI interface (12% or 25%). With this feature the device can drive loads with start-up currents higher than the over-current limits (e.g. inrush current of lamps, cold resistance of motors and heaters).

3.5 Over-voltage and under-voltage detection

If the power supply voltage V_S rises above the over-voltage threshold $V_{SOV\ OFF}$ (typical 21V), the outputs OUT1 to OUT5 are switched to high impedance state to protect the load and the internal charge-pump is turned-off. When the voltage V_S drops below the undervoltage threshold $V_{SUV\ OFF}$ (UV-switch-OFF voltage), the output stages are switched to the high impedance to avoid the operation of the power devices without sufficient gate driving voltage (increased power dissipation). If the supply voltage V_S recovers to normal operating voltage the output stages return to the programmed state (input register 0: bit 12=0). If the undervoltage / overvoltage recovery disable bit is set, the automatic turn-on of the drivers is deactivated. The microcontroller needs to clear the status bits to reactivate the drivers.

3.6 Temperature warning and thermal shutdown

If junction temperature rises above $T_{j\ TW}$ a temperature warning flag is set and is detectable via the SPI. If junction temperature increases above the second threshold $T_{j\ SD}$, the thermal shutdown bit will be set and power DMOS transistors of all output stages are switched off to protect the device. In order to reactivate the output stages the junction temperature must decrease below $T_{j\ SD} - T_{j\ SD\ HYS}$ and the thermal shutdown bit has to be cleared by the microcontroller.

3.7 Open-load detection

The open-load detection monitors the load current in each activated output stage. If the load current is below the open-load detection threshold for at least 1 ms (t_{dOL}) the corresponding open-load bit is set in the status register. Due to mechanical/electrical inertia of typical loads a short activation of the outputs (e.g. 3ms) can be used to test the open-load status without changing the mechanical/electrical state of the loads.

3.8 Over load detection

In case of an over-current condition a flag is set in the status register in the same way as open-load detection. If the over-current signal is valid for at least $t_{ISC}=32\mu s$, the over-current flag is set and the corresponding driver is switched off to reduce the power dissipation and to protect the integrated circuit. If the over-current recovery bit of the output is zero the microcontroller has to clear the status bits to reactivate the corresponding driver.

3.9 Current monitor

The current monitor output sources a current image at the current monitor output which has a fixed ratio (1/10000) of the instantaneous current of the selected high side driver. The bits 9, 10 and 11 of the input data register 0 control which of the outputs OUT1 to OUT5 will be multiplexed to the current monitor output. The current monitor output allows a more precise analysis of the actual state of the load rather than the detection of an open- or overload condition. For example this can be used to detect the motor state (starting, free-running, stalled). Moreover, it is possible to regulate the power of the defroster more precise by measuring the monitor current.

3.10 PWM input

Each driver has a corresponding PWM enable bit which can be programmed by the SPI interface. If the PWM enable bit is set, the outputs OUT1 to OUT5 are controlled by the logically AND-combination of the signal applied to the PWM input and the output control bit in input data register1.

3.11 Cross-current protection

The three half-bridges of the device are cross-current protected by an internal delay time. If one driver (LS or HS) is turned-off the activation of the other driver of the same half bridge will be automatically delayed by the cross-current protection time. After the cross-current protection time is expired the slew-rate limited switch-off phase of the driver will be changed to a fast turn-off phase and the opposite driver is turned-on with slew-rate limitation. Due to this behavior it is always guaranteed that the previously activated driver is totally turned-off before the opposite driver will start to conduct.

3.12 Programmable softstart function to drive loads with higher inrush current

Loads with start-up currents higher than the over-current limits (e.g. inrush current of lamps, start current of motors and cold resistance of heaters) can be driven by using the programmable softstart function (i.e. overcurrent recovery mode). Each driver has a corresponding over-current recovery bit. If this bit is set, the device will automatically switch-on the outputs again after a programmable recovery time. The duty cycle in over-current condition can be programmed by the SPI interface to be about 12% or 25%. The PWM modulated current will provide sufficient average current to power up the load (e.g. heat up the bulb) until the load reaches operating condition.

The device itself cannot distinguish between a real overload and a non linear load like a light bulb. A real overload condition can only be qualified by time. As an example the microcontroller can switch on light bulbs by setting the over-current Recovery bit for the first 50ms. After clearing the recovery bit the output will be automatically disabled if the overload condition still exists.

Figure 9. Example of programmable softstart function for inductive loads

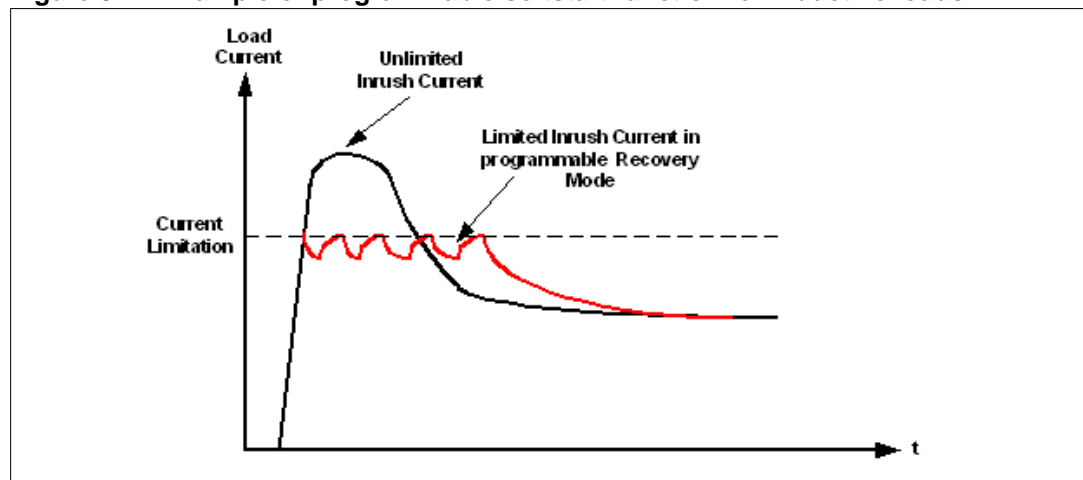

4 Functional description of the SPI

4.1 Serial Peripheral Interface (SPI)

This device uses a standard SPI to communicate with a microcontroller. The SPI can be driven by a microcontroller with its SPI peripheral running in following mode: CPOL = 0 and CPHA = 0.

For this mode, input data is sampled by the low to high transition of the clock CLK, and output data is changed from the high to low transition of CLK.

This device is not limited to microcontroller with a build-in SPI. Only three CMOS-compatible output pins and one input pin will be needed to communicate with the device. A fault condition can be detected by setting CSN to low. If CSN = 0, the DO-pin will reflect the status bit 0 (fault condition) of the device which is a logical-or of all bits in the status registers 0 and 1. The microcontroller can poll the status of the device without the need of a full SPI-communication cycle.

Note: In contrast to the SPI-standard the least significant bit (LSB) will be transferred first (see [Figure 3](#)).

4.2 Chip Select Not (CSN)

The input pin is used to select the serial interface of this device. When CSN is high, the output pin (DO) will be in high impedance state. A low signal will activate the output driver and a serial communication can be started.

The state when CSN is going low until the rising edge of CSN will be called a communication frame. If the CSN-input pin is driven above 7.5V, the L9951 will go into a test mode. In the test mode the DO will go from tristate to active mode.

4.3 Serial Data In (DI)

The input pin is used to transfer data serial into the device. The data applied to the DI will be sampled at the rising edge of the CLK signal and shifted into an internal 16 bit shift register. At the rising edge of the CSN signal the contents of the shift register will be transferred to Data Input Register.

The writing to the selected Data Input Register is only enabled if exactly 16 bits are transmitted within one communication frame (i.e. CSN low). If more or less clock pulses are counted within one frame the complete frame will be ignored. This safety function is implemented to avoid an activation of the output stages by a wrong communication frame.

Note: Due to this safety functionality a daisy chaining of SPI is not possible. Instead, a parallel operation of the SPI bus by controlling the CSN signal of the connected ICs is recommended.

4.4 Serial Data Out (DO)

The data output driver is activated by a logical low level at the CSN input and will go from high impedance to a low or high level depending on the status bit 0 (fault condition). The first rising edge of the CLK input after a high to low transition of the CSN pin will transfer the content of the selected status register into the data out shift register. Each subsequent falling edge of the CLK will shift the next bit out.

4.5 Serial clock (CLK)

The CLK input is used to synchronize the input and output serial bit streams. The data input (DI) is sampled at the rising edge of the CLK and the data output (DO) will change with the falling edge of the CLK signal.

4.6 Input data register

The device has two input registers. The first bit (bit 0) at the DI-input is used to select one of the two input registers. All bits are first shifted into an input shift register. After the rising edge of CSN the contents of the input shift register will be written to the selected input data register only if a frame of exact 16 data bits are detected. Depending on bit 0 the contents of the selected status register will be transferred to DO during the current communication frame. Bit 1-8 control the behavior of the corresponding driver. The bits 9,10 and 11 are used to control the current monitor multiplexer. Bit 15 is used to reset all status bits in both status registers. The bits in the status registers will be cleared after the current communication frame (rising edge of CSN).

4.7 Status register

This device uses two status registers to store and to monitor the state of the device. Bit 0 is used as a fault bit and is a logical-NOR combination of bits 1-14 in both status registers. The state of this bit can be polled by the microcontroller without the need of a full SPI-communication cycle (see [Figure 8](#)). If one of the over-current bits is set, the corresponding driver will be disabled. If the over-current recovery bit of the output is not set the microcontroller has to clear the over-current bit to enable the driver. If the thermal shutdown bit is set, all drivers will go into a high impedance state. Again the microcontroller has to clear the bit to enable the drivers.

4.8 Test mode

The test mode can be entered by rising the CSN input to a voltage higher than 7.5V. In the test mode the inputs CLK, DI, PWM and the internal 2MHz CLK can be multiplexed to data output DO for testing purpose. Furthermore the over-current thresholds are reduced by a factor of 4 to allow EWS testing at lower current. The internal logic prevents that the Hi-Side and Low-Side driver of the same half-bridge can be switched-on at the same time. In the test mode this combination is used to multiplex the desired signals to the CM output according to table 18 and 19.

Table 18. Test mode

LS1 HS1	LS2 HS2	LS3 HS3	DO	LS1 HS1	LS2 HS2	LS3 HS3	CM
! (both HI)	! (both HI)	! (both HI)	NoError	! (both HI)	! (both HI)	! (both HI)	N.C
both HI	! (both HI)	! (both HI)	DI	both HI	! (both HI)	! (both HI)	Tsense1
! (both HI)	both HI	! (both HI)	CLK	! (both HI)	both HI	! (both HI)	Tsense2
both HI	both HI	! (both HI)	INT_CLK	both HI	both HI	! (both HI)	Tsense3
! (both HI)	! (both HI)	both HI	PWM	! (both HI)	! (both HI)	both HI	Tsense4
				both HI	! (both HI)	both HI	N.C
				! (both HI)	both HI	both HI	5µA Iref
				both HI	both HI	both HI	Vbandgap

Table 19. SPI - Input data and status register 0

Input register 0 (write)			Status register 0 (read)	
Bit	Name	Comment	Name	Comment
15	Reset bit	If reset bit is set both status registers will be cleared after rising edge of CSN input.	Always 1	A broken VCC-or SPI-connection of the L9951 can be detected by the microcontroller, because all 16 bits low or high is not a valid frame.
14	Disable open-load	If the disable open-load bit is set, the open-load status bits will be ignored for the NonErrorBit calculation.	V _S over-voltage	In case of an over-voltage or undervoltage event the corresponding bit is set and the outputs are deactivated.
13	OC recovery duty cycle 0: 12% 1: 25%	This bit defines in combination with the over-current recovery bit (input register 1) the duty cycle in over-current condition of an activated driver. If temperature warning bit is set, L9951 will always use the lower duty cycle	V _S undervoltage	If VS voltage recovers to normal operating conditions outputs are reactivated automatically.
12	Overvoltage/under-voltage recovery disable	If this bit is set the microcontroller has to clear the status register after undervoltage/overvoltage event to enable the outputs.	Thermal shutdown	In case of a thermal shutdown all outputs are switched off. The microcontroller has to clear the TSD bit by setting the reset bit to reactivate the outputs.

Table 19. SPI - Input data and status register 0 (continued)

Input register 0 (write)				Status register 0 (read)																									
Bit	Name	Comment		Name	Comment																								
11	Current monitor select bits	Following current image (1/10.000) of the HS driver will be multiplexed to CM output: <table border="1" data-bbox="603 633 880 795"> <thead> <tr> <th>Bit 11</th> <th>Bit 10</th> <th>Bit 9</th> <th>Output</th> </tr> </thead> <tbody> <tr> <td>0</td> <td>0</td> <td>0</td> <td>OUT1</td> </tr> <tr> <td>0</td> <td>0</td> <td>1</td> <td>OUT2</td> </tr> <tr> <td>0</td> <td>1</td> <td>0</td> <td>OUT3</td> </tr> <tr> <td>0</td> <td>1</td> <td>1</td> <td>OUT4</td> </tr> <tr> <td>1</td> <td>0</td> <td>0</td> <td>OUT5</td> </tr> </tbody> </table>		Bit 11	Bit 10	Bit 9	Output	0	0	0	OUT1	0	0	1	OUT2	0	1	0	OUT3	0	1	1	OUT4	1	0	0	OUT5	Temperature warning	This bit is for information purpose only. It can be used for a thermal management by the microcontroller to avoid a thermal shutdown.
Bit 11				Bit 10	Bit 9	Output																							
0				0	0	OUT1																							
0	0	1	OUT2																										
0	1	0	OUT3																										
0	1	1	OUT4																										
1	0	0	OUT5																										
10	Not ready bit	After switching the device from standby mode to active mode an internal timer is started to allow charge pump to settle before the outputs can be activated. This bit is cleared automatically after start up time has finished. Since this bit is controlled by internal clock it can be used for synchronizing testing events (e.g. measuring filter times).																											
9			0	Not used																									
8	OUT5 - HS on/off	If a bit is set the selected output driver is switched on. If the corresponding PWM enable bit is set (Input Register 1) the driver is only activated if PWM input signal is high. The outputs of OUT1-OUT3 are half bridges. If the bits of HS- and LS-driver of the same half bridge are set, the internal logic prevents that both drivers of this output stage can be switched on simultaneously in order to avoid a high internal current from VS to GND.		OUT5-HS over - current	In case of an over-current event the corresponding status bit is set and the output driver is disabled. If the over-current recovery enable bit is set (Input Register 1) the output will be automatically reactivated after a delay time resulting in a PWM modulated current with a programmable duty cycle (Bit 13). If the over-current recovery bit is not set the microcontroller has to clear the over-current bit (reset bit) to reactivate the output driver.																								
7	OUT4 - HS on/off			OUT4-HS over - current																									
6	OUT3 - HS on/off			OUT3-HS over - current																									
5	OUT3 - LS on/off			OUT3-LS over - current																									
4	OUT2 - HS on/off			OUT2-HS over - current																									
3	OUT2 - LS on/off			OUT2-LS over - current																									
2	OUT1 - HS on/off			OUT1-HS over - current																									
1	OUT1 - LS on/off			OUT1-LS over - current																									
0		0	No error bit	A logical NOR-combination of all bits 1 to 14 in both status registers. If bit 14 (disable open-load) is set, the open-load status will be ignored.																									

Table 20. SPI - Input data and status register 1

Input register 1 (write)			Status register 1 (read)	
Bit	Name	Comment	Name	Comment
15	Not used		Always 1	A broken VCC-or SPI-connection of the L9951 can be detected by the microcontroller, because all 16 bits low or high is not a valid frame.
14	Not used		V _S over-voltage	In case of an over-voltage or undervoltage event the corresponding bit is set and the outputs are deactivated.
13	Not used		V _S undervoltage	In case of an over-voltage or undervoltage event the corresponding bit is set and the outputs are deactivated.
12	Not used		Thermal shutdown	In case of an thermal shutdown all outputs are switched off. The microcontroller has to clear the TSD bit by setting the reset bit to reactivate the outputs.
11	Not used		Temperature warning	This bit is for information purpose only. It can be used for a thermal management by the microcontroller to avoid a thermal shutdown.

Table 20. SPI - Input data and status register 1 (continued)

Input register 1 (write)			Status register 1 (read)	
Bit	Name	Comment	Name	Comment
10	OUT5 OC recovery enable	In case of an over-current event the over-current status bit (status register 0) is set and the output is switched off. If the over-current recovery enable bit is set the output will be automatically reactivated after a delay time resulting in a PWM modulated current with a programmable duty cycle (Bit 13 of Input data register 1).	Not ready bit	After switching the device from standby mode to active mode an internal timer is started to allow charge pump to settle before the outputs can be activated. This bit is cleared automatically after start up time has finished. Since this bit is controlled by internal clock it can be used for synchronizing testing events(e.g. measuring filter times).
9	OUT4 OC recovery enable	Depending on occurrence of overcurrent event and internal clock phase it is possible that one recovery cycle is executed even if this bit is set to zero.	0	Not used.
8	OUT3 OC recovery enable		OUT5-HS open-load	The open-load detection monitors the load current in each activated output stage. If the load current is below the open-load detection threshold for at least 1 ms (t_{dOL}) the corresponding open-load bit is set. Due to mechanical /electrical inertia of typical loads a short activation of the outputs (e.g. 3ms) can be used to test the open-load status without changing the mechanical/electrical state of the loads.
7	OUT2 OC recovery enable		OUT4-HS open-load	
6	OUT1 OC recovery enable		OUT3-HS open-load	
5	OUT5 PWM enable	If the PWM enable bit is set and the output is enabled (input register 0) the output is switched on if PWM input is high and switched off if PWM input is low.	OUT3-LS open-load	
4	OUT4 PWM enable		OUT2-HS open-load	
3	OUT3 PWM enable		OUT2-LS open-load	
2	OUT2 PWM enable		OUT1-HS open-load	
1	OUT1 PWM enable		OUT1-LS open-load	
0		1	No error bit	A logical NOR-combination of all bits 1 to 14 in both status registers. If bit 14 (Disable Open-Load) is set, the open-load status will be ignored

5 Packages thermal data

Figure 10. Packages thermal data

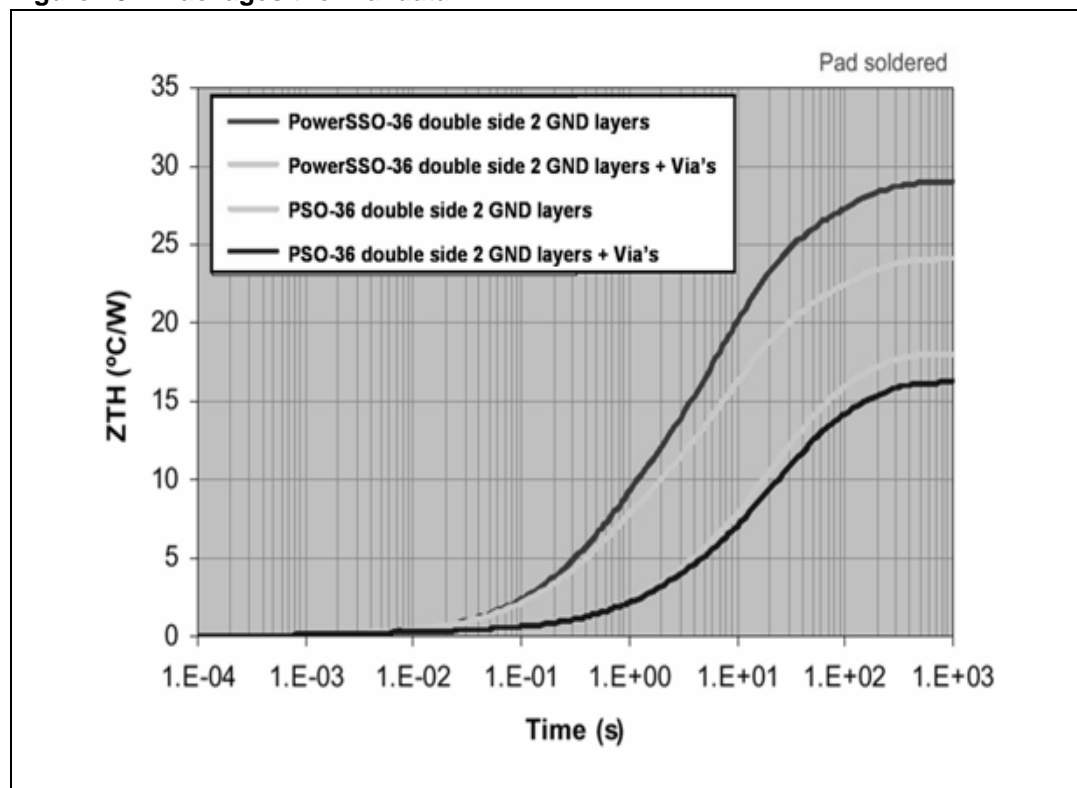

6 Package and packing information

6.1 ECOPACK[®] packages

In order to meet environmental requirements, ST offers these devices in different grades of ECOPACK[®] packages, depending on their level of environmental compliance. ECOPACK[®] specifications, grade definitions and product status are available at: www.st.com.

ECOPACK[®] is an ST trademark.

6.2 PowerSO-36[™] package information

Figure 11. PowerSO-36[™] package dimensions

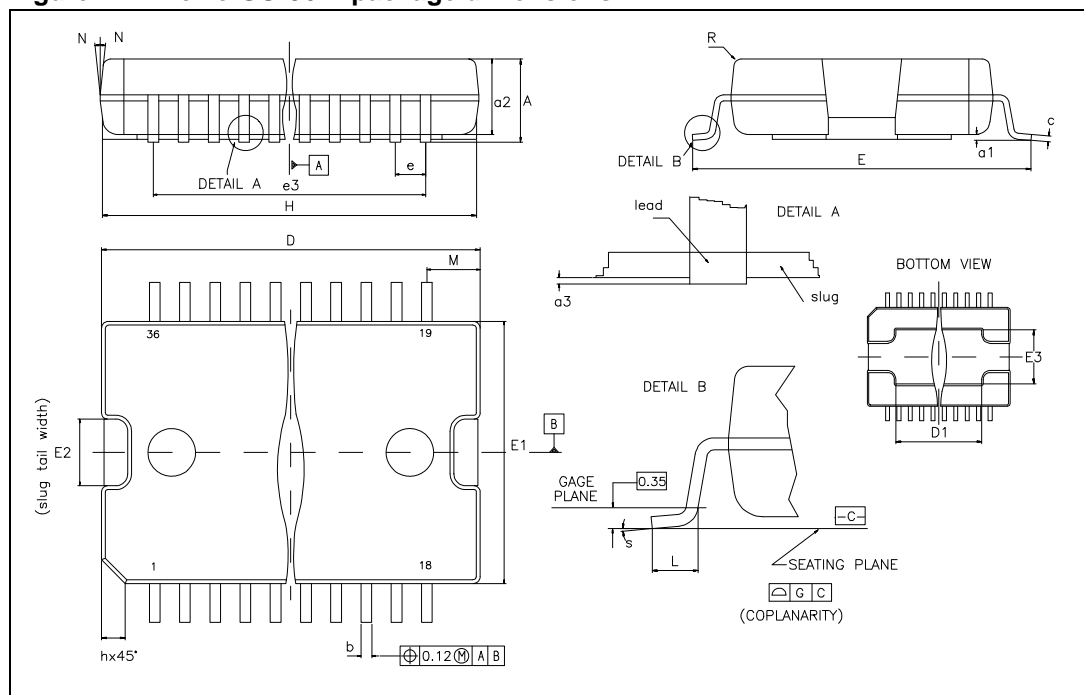

Table 21. PowerSO-36[™] mechanical data

Symbol	Millimeters		
	Min.	Typ.	Max.
A			3.60
a1	0.10		0.30
a2			3.30
a3	0		0.10
b	0.22		0.38
c	0.23		0.32

Table 21. PowerSO-36™ mechanical data (continued)

Symbol	Millimeters		
	Min.	Typ.	Max.
D *	15.80		16.00
D1	9.40		9.80
E	13.90		14.5
E1 *	10.90		11.10
E2			2.90
E3	5.80		6.20
e		0.65	
e3		11.05	
G	0		0.10
H	15.50		15.90
h			1.10
L	0.8		1.10
M			
N			10 deg
R			
s			8 deg

6.3 PowerSSO-36™ package information

Figure 12. PowerSSO-36™ package dimensions

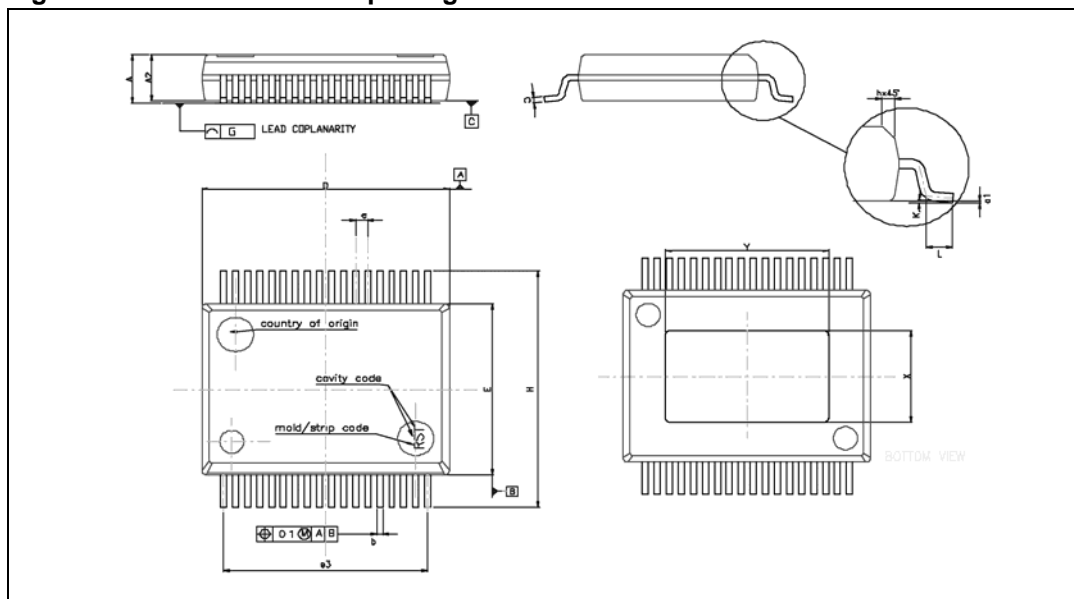
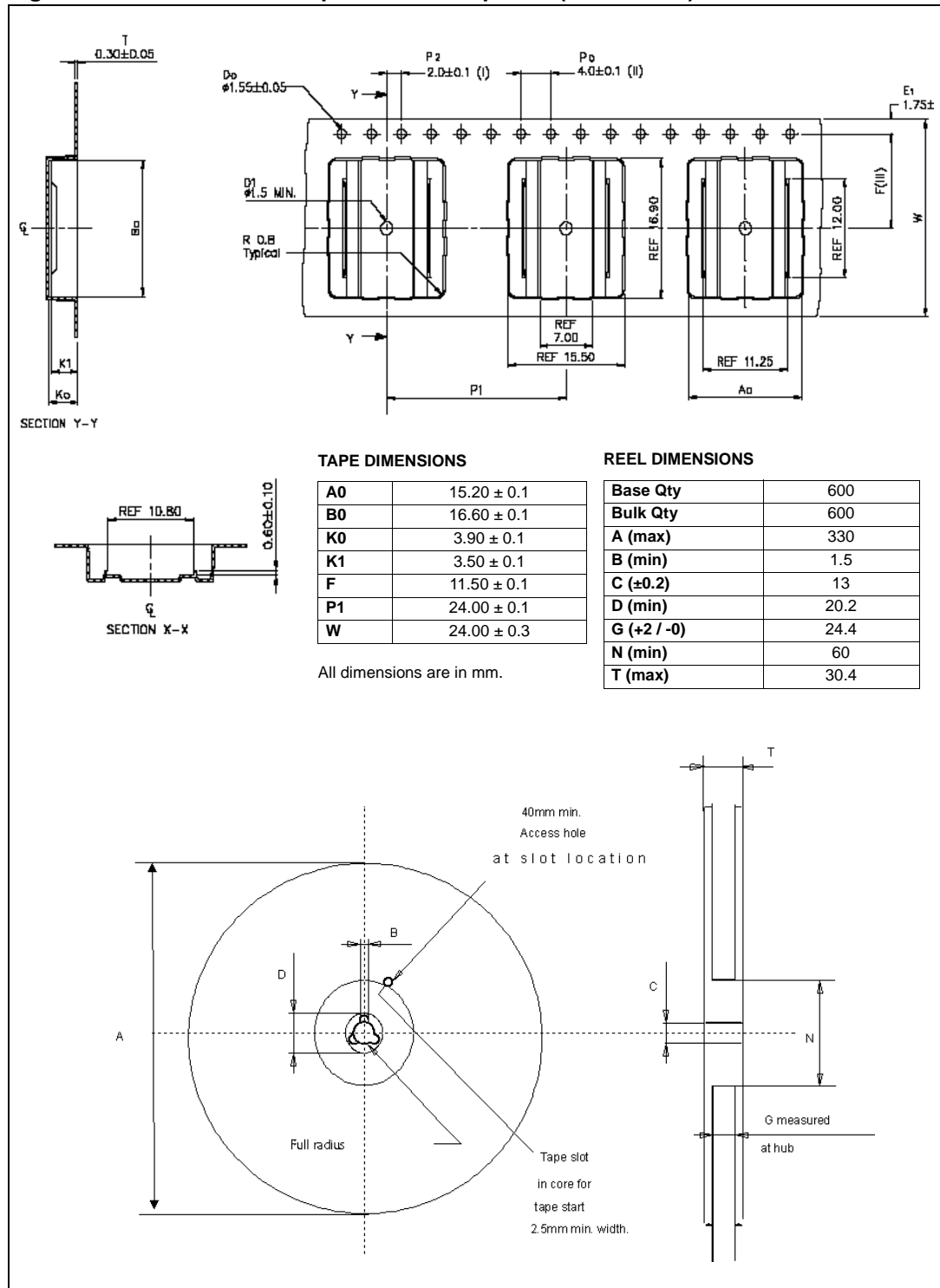

Table 22. PowerSSO-36™ mechanical data

Symbol	Millimeters		
	Min.	Typ.	Max.
A	-	-	2.45
A2	2.15	-	2.35
a1	0	-	0.1
b	0.18	-	0.36
c	0.23	-	0.32
D *	10.10	-	10.50
E *	7.4	-	7.6
e	-	0.5	-
e3	-	8.5	-
F	-	2.3	-
G	-	-	0.1
G1	-	-	0.06
H	10.1	-	10.5
h	-	-	0.4
k	0°	-	8°
L	0.55	-	0.85
N	-	-	10 deg

Figure 14. PowerSO-36™ tape and reel shipment (suffix “TR”)



6.5 PowerSSO-36™ packing information

Figure 15. PowerSSO-36™ tube shipment (no suffix)

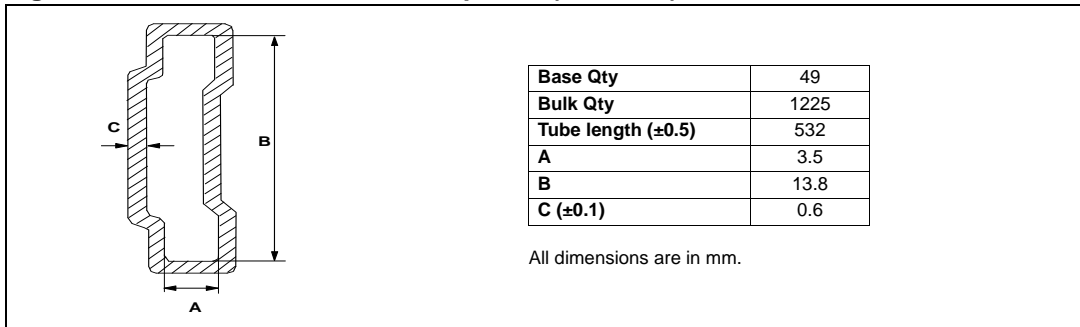
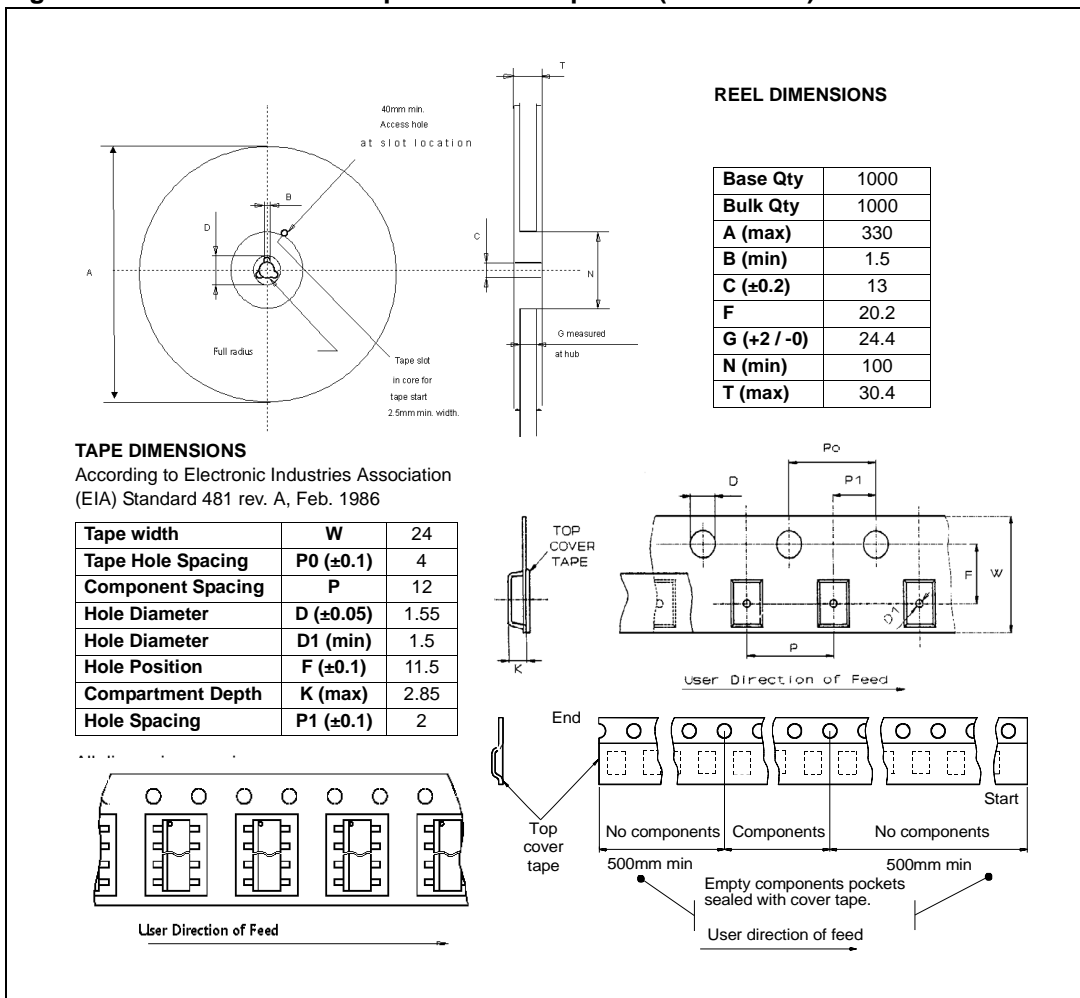

Figure 16. PowerSSO-36™ tape and reel shipment (suffix “TR”)



7 Revision history

Table 23. Document revision history

Date	Revision	Description of changes
Mar-2004	1	First issue
Jun-2005	2	Added <i>PowerSO-36™ package information</i> , <i>PowerSO-36™ package information</i> .
Jul-2005	3	Updated <i>Figure 1.: Block diagram</i> .
Sep-2005	4	Note 1 removal; Updated <i>Figure 10.: Packages thermal data</i> .
Feb-2006	5	Updated <i>Table 4.: ESD protection</i> .
15-Nov-2007	6	Document restructured and reformatted. Added <i>PowerSO-36™ packing information</i> and <i>PowerSSO-36™ packing information</i> .
24-Jun-2009	7	<i>Table 22: PowerSSO-36™ mechanical data:</i> – Deleted A (min) value – Changed A (max) value from 2.47 to 2.45 – Changed A2 (max) value from 2.40 to 2.35 – Changed a1 (max) value from 0.075 to 0.1 – Added F and k rows
14-May-2010	8	<i>Table 22: PowerSSO-36™ mechanical data:</i> – Changed X: minimum value from 4.1 to 4.3 and maximum value from 4.7 to 5.2 – Changed Y: minimum value from 6.5 to 6.9 and maximum value from 7.1 to 7.5
22-Sep-2013	9	Updated Disclaimer.

Please Read Carefully:

Information in this document is provided solely in connection with ST products. STMicroelectronics NV and its subsidiaries ("ST") reserve the right to make changes, corrections, modifications or improvements, to this document, and the products and services described herein at any time, without notice.

All ST products are sold pursuant to ST's terms and conditions of sale.

Purchasers are solely responsible for the choice, selection and use of the ST products and services described herein, and ST assumes no liability whatsoever relating to the choice, selection or use of the ST products and services described herein.

No license, express or implied, by estoppel or otherwise, to any intellectual property rights is granted under this document. If any part of this document refers to any third party products or services it shall not be deemed a license grant by ST for the use of such third party products or services, or any intellectual property contained therein or considered as a warranty covering the use in any manner whatsoever of such third party products or services or any intellectual property contained therein.

UNLESS OTHERWISE SET FORTH IN ST'S TERMS AND CONDITIONS OF SALE ST DISCLAIMS ANY EXPRESS OR IMPLIED WARRANTY WITH RESPECT TO THE USE AND/OR SALE OF ST PRODUCTS INCLUDING WITHOUT LIMITATION IMPLIED WARRANTIES OF MERCHANTABILITY, FITNESS FOR A PARTICULAR PURPOSE (AND THEIR EQUIVALENTS UNDER THE LAWS OF ANY JURISDICTION), OR INFRINGEMENT OF ANY PATENT, COPYRIGHT OR OTHER INTELLECTUAL PROPERTY RIGHT.

ST PRODUCTS ARE NOT DESIGNED OR AUTHORIZED FOR USE IN: (A) SAFETY CRITICAL APPLICATIONS SUCH AS LIFE SUPPORTING, ACTIVE IMPLANTED DEVICES OR SYSTEMS WITH PRODUCT FUNCTIONAL SAFETY REQUIREMENTS; (B) AERONAUTIC APPLICATIONS; (C) AUTOMOTIVE APPLICATIONS OR ENVIRONMENTS, AND/OR (D) AEROSPACE APPLICATIONS OR ENVIRONMENTS. WHERE ST PRODUCTS ARE NOT DESIGNED FOR SUCH USE, THE PURCHASER SHALL USE PRODUCTS AT PURCHASER'S SOLE RISK, EVEN IF ST HAS BEEN INFORMED IN WRITING OF SUCH USAGE, UNLESS A PRODUCT IS EXPRESSLY DESIGNATED BY ST AS BEING INTENDED FOR "AUTOMOTIVE, AUTOMOTIVE SAFETY OR MEDICAL" INDUSTRY DOMAINS ACCORDING TO ST PRODUCT DESIGN SPECIFICATIONS. PRODUCTS FORMALLY ESCC, QML OR JAN QUALIFIED ARE DEEMED SUITABLE FOR USE IN AEROSPACE BY THE CORRESPONDING GOVERNMENTAL AGENCY.

Resale of ST products with provisions different from the statements and/or technical features set forth in this document shall immediately void any warranty granted by ST for the ST product or service described herein and shall not create or extend in any manner whatsoever, any liability of ST.

ST and the ST logo are trademarks or registered trademarks of ST in various countries.

Information in this document supersedes and replaces all information previously supplied.

The ST logo is a registered trademark of STMicroelectronics. All other names are the property of their respective owners.

© 2013 STMicroelectronics - All rights reserved



STMicroelectronics group of companies

Australia - Belgium - Brazil - Canada - China - Czech Republic - Finland - France - Germany - Hong Kong - India - Israel - Italy - Japan - Malaysia - Malta - Morocco - Philippines - Singapore - Spain - Sweden - Switzerland - United Kingdom - United States of America

www.st.com

Looking for pricing, stock, or lifecycle information?

Click below to explore more details on WIN SOURCE:

-  [View L9951XP](#) on WIN SOURCE
-  [STMicroelectronics](#) Information

Optimize Your Supply Chain with WIN SOURCE Solutions

-  Global Sourcing Solution
-  Obsolete Management
-  Cost Control Management
-  Shortage Management
-  Alternative Solution
-  Excess Inventory Management