



THE DATASHEET OF LD1117-5.0



DESCRIPTION

The LD1117 is a positive low voltage dropout regulator; typical voltage dropout is only 1.2V at 1A.

LD1117 provides two versions: fixed and adjustable versions. VOUT has a tolerance of less than 1.5% for fixed versions 1.2V, 1.5V, 1.8V, 2.5V, 3.3V, 5.0V and adjustable version or 2% output accuracy for fixed version 1.2V.

The LD1117 offers some key features include thermal shutdown and current limiting. It is suitable for all electronic products.

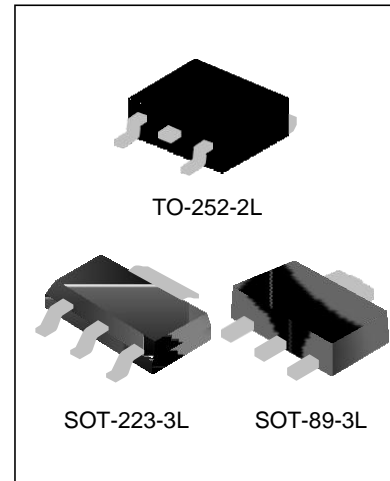

FEATURES

- ◆ 1.5% output accuracy for fixed versions 1.2V, 1.5V, 1.8V, 2.5V, 3.3V, 5.0V and adjustable version
- ◆ Adjustable output voltage
- ◆ Low Dropout Voltage: Typical 1.2V@1A
- ◆ Current Limiting
- ◆ Thermal Shutdown
- ◆ Temperature Range: -40°C to 125°C

APPLICATIONS

- ◆ Laptop, Palmtop, and Notebook Computers
- ◆ Battery Charger
- ◆ SCSI-II Active Terminator
- ◆ Cellular Phone
- ◆ Cordless Telephones
- ◆ Battery Powered Systems
- ◆ Portable Instrumentation
- ◆ SMPS Post-Regulator

NOMENCLATURE

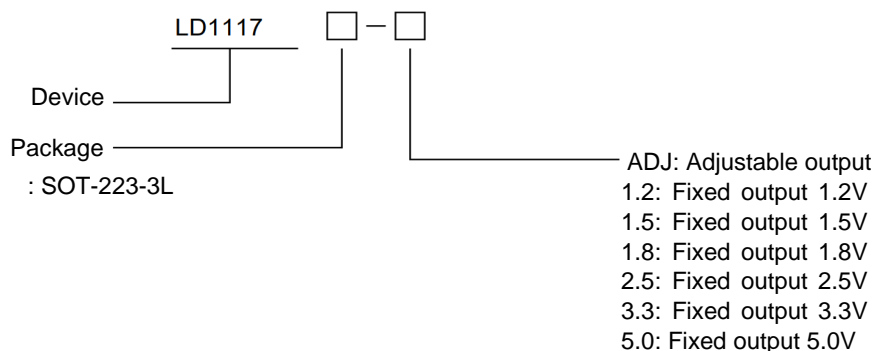

BLOCK DIAGRAM

1A LDO Voltage Regulator

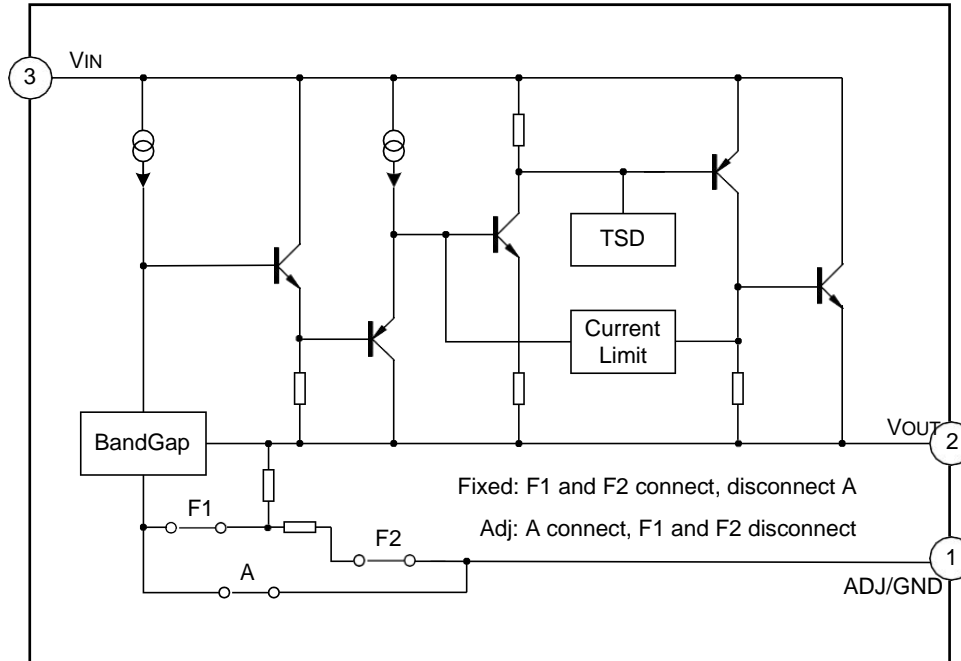

ABSOLUTE MAXIMUM RATINGS

Characteristics		Symbol	Rating	Unit
Input Supply Voltage		V_{IN}	15	V
Lead Temperature (Soldering, 5 seconds)		T_{Lead}	260	°C
Operating Junction Temperature Range		T_J	150	°C
Storage Temperature Range		T_{stg}	-65 ~ +150	V
Power Dissipation		P_D	Internally Limited (Note1)	mW
Thermal Resistance from Junction to Ambient	SOT-223-3L	R_{ja}	88	°C/W
	TO-252-2L		86	
	SOT-89-3L		102	
ESD Tolerance (Minimum)		ESD	2000	V

Note1: The maximum allowable power dissipation is a function of maximum operating junction temperature, T_J (max), the junction to ambient thermal resistance, R_{ja} , and the ambient temperature T_{amb} . The maximum allowable power dissipation at any ambient temperature is given: $P_{D(max)} = (T_J(max) - T_{amb}) / R_{ja}$, exceeding the maximum allowable power limit will result in excessive die temperature; thus, the regulator will go into thermal shutdown. The junction to ambient thermal resistance, θ_{JA} of some packages may be different, The value of θ_{JA} depends on mounting technique.

RECOMMENDED OPERATING CONDITIONS

Characteristics	Symbol	Rating	Unit
Input voltage	V_{IN}	12	V
Operating Junction Temperature Range	T_J	-40 ~ +125	°C

1A LDO Voltage Regulator
ELECTRICAL CHARACTERISTICS

Characteristics	Symbol	Conditions	Min.	Typ.	Max.	Unit
Reference Voltage	V_{REF}	LD1117-ADJ, $I_{OUT}=10mA, V_{IN}-V_{OUT}=2V, T_J=25^{\circ}C$ $10mA \leq I_{OUT} \leq 1A, 1.4V \leq V_{IN}-V_{OUT} \leq 10V$	1.231 1.225	1.250 1.250	1.268 1.275	V
Output Voltage	V_{OUT}	LD1117-1.2, $I_{OUT}=10mA, V_{IN}=3.2V, T_J=25^{\circ}C$ $10mA \leq I_{OUT} \leq 1A, 3.0V \leq V_{IN} \leq 10V$	1.176 1.152	1.2 1.2	1.224 1.248	V
		LD1117-1.5, $I_{OUT}=10mA, V_{IN}=3.5V, T_J=25^{\circ}C$ $10mA \leq I_{OUT} \leq 1A, 3.0V \leq V_{IN} \leq 10V$	1.477 1.470	1.500 1.500	1.5221 .530	V
		LD1117-1.8, $I_{OUT}=10mA, V_{IN}=3.8V, T_J=25^{\circ}C,$ $0 \leq I_{OUT} \leq 1A, 3.2V \leq V_{IN} \leq 10V$	1.7731 .746	1.800 1.800	1.827 1.854	V
		LD1117-2.5, $I_{OUT}=10mA, V_{IN}=4.5V, T_J=25^{\circ}C,$ $0 \leq I_{OUT} \leq 1A, 3.9V \leq V_{IN} \leq 10V$	2.462 2.450	2.500 2.500	2.538 2.550	V
		LD1117-3.3, $I_{OUT}=10mA, V_{IN}=5V, T_J=25^{\circ}C,$ $0 \leq I_{OUT} \leq 1A, 4.75V \leq V_{IN} \leq 10V$	3.250 3.235	3.300 3.300	3.349 3.365	V
		LD1117-5.0, $I_{OUT}=10mA, V_{IN}=7V, T_J=25^{\circ}C,$ $0 \leq I_{OUT} \leq 1A, 6.5V \leq V_{IN} \leq 12V$	4.925 4.900	5.000 5.000	5.075 5.10	V
Output Voltage Temperature Stability	TS_{OUT}		--	0.3	--	%
Line Regulation	R_{line}	$V_{INMIN} \leq V_{IN} \leq 12V,$ $V_{OUT}=\text{Fixed/Adj}, I_{OUT}=10mA$	--	9	18	mV
Load Regulation	R_{load}	$10mA \leq I_{OUT} \leq 1A, V_{OUT}=\text{Fixed/Adj}$	--	10	18	mV
Dropout Voltage	V_{drop}	$I_{OUT}=100mA$ $I_{OUT}=500mA$ $I_{OUT}=1A$	--	1.00 1.05 1.20	1.20 1.25 1.30	V
Quiescent Current	I_q	$4.25V \leq V_{IN} \leq 6.5V$	--	5	10	mA
Ripple Rejection	P_{SRR}	$f_{RIPPLE}=120Hz, (V_{IN}-V_{OUT})=3V,$ $V_{RIPPLE}=1V_{PP}$	60	75	--	dB
Adjust pin Current	I_{adj}		--	60	120	μA
Adjust pin Current Change		$0 \leq I_{OUT} \leq 1A, 1.4V \leq V_{IN}-V_{OUT} \leq 10V$	--	0.2	5	μA
Thermal shutdown	TSD		--	150	--	$^{\circ}C$
Current limiting	I_{limit}		2.1	--	2.5	A
Temperature Stability			--	0.5	--	%
Long Term Stability		$T_A=125^{\circ}C, 1000Hrs$	--	0.3	--	%

Characteristics	Symbol	Conditions	Min.	Typ.	Max.	Unit
RMS Output Noise		% of V_{OUT} , $10\text{Hz} \leq f \leq 10\text{kHz}$	--	0.003	--	%

PIN CONFIGURATION

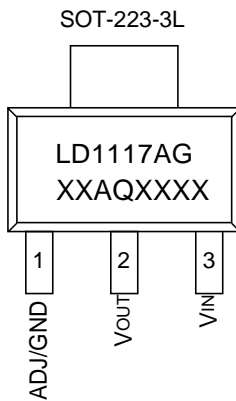

"XX": Voltage
 "XXXX": LOT NO.

PIN DESCRIPTION

Pin No.	Pin name	I/O	Functions
1	GND/ADJ	--/O	Ground/ADJ
2	VOUT	O	Output voltage
3	VIN	I	Input supply voltage

FUNCTION DESCRIPTION

The LD1117 is a LDO regulator, its pass transistor is made up of a single NPN transistor being driven by a PNP. The dropout voltage is defined as: $V_{DROP} = V_{BE} + V_{SAT}$.
 The LD1117 series of fixed and adjustable regulators are easy to use. Output voltages are 1.2V, 1.5V, 1.8V, 2.5V, 3.3V, and 5.0V. On-chip thermal shut down provides protection against any combination of overload and ambient temperature that would create excessive junction temperature.
 The LD1117 requires an output capacitor for device stability. Its value of 22μF tantalum covers all cases of bypassing the adjustment terminal. Without bypassing the adjustment terminal smaller capacitors can be used with equally good results which depend upon the application circuit. In general, linear regulator stability decreases with higher output currents.

TYPICAL APPLICATION CIRCUIT

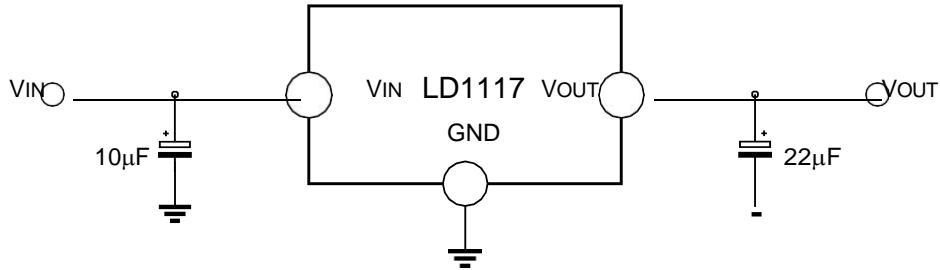

Figure 1. Typical Fixed Output Voltage

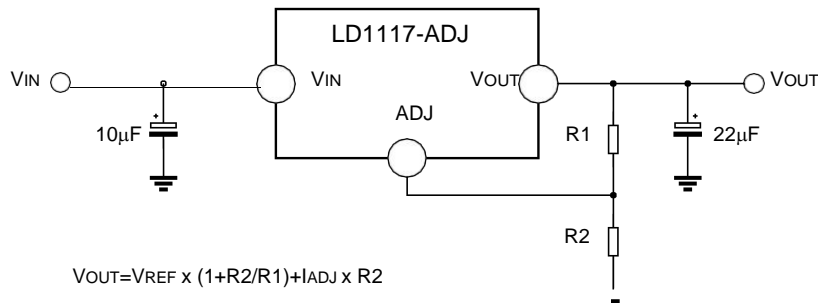
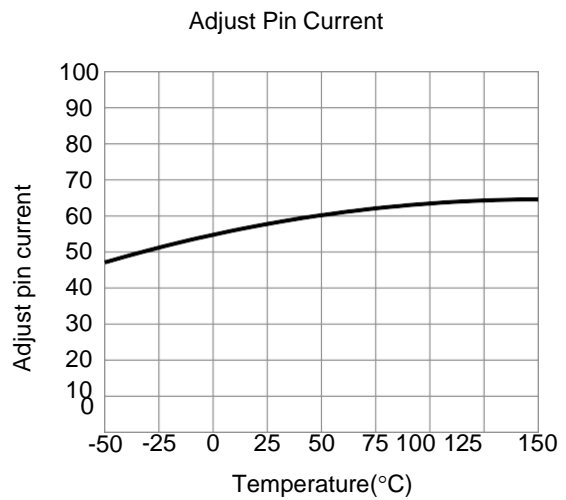
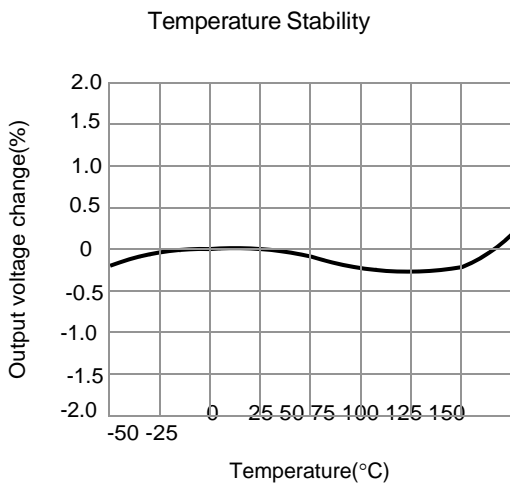

Figure 2. Typical Adjustable Output Voltage

Note: The circuit and parameters are reference only, please set the parameters of the real application circuit based on the real test.

TYPICAL CHARACTERISTICS



TYPICAL CHARACTERISTICS CURVES(continued)

$V_{OUT}=5\text{ V}$ Load Transient Response

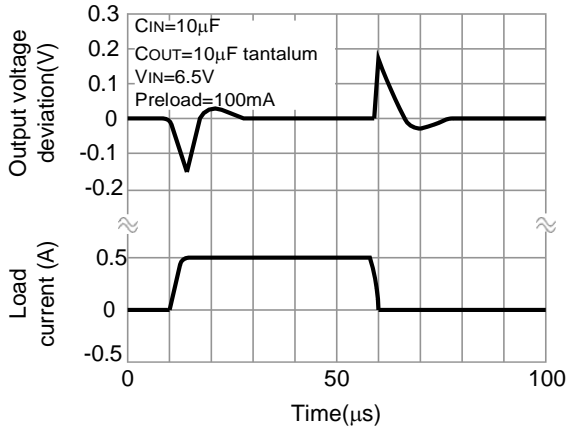

$V_{OUT}=5\text{ V}$ Line Transient Response

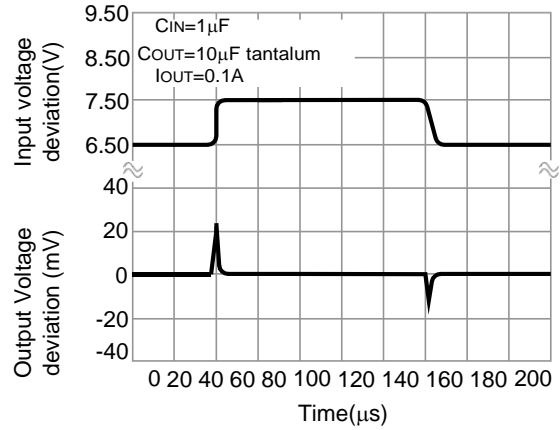

Ripple Rejection VS Current

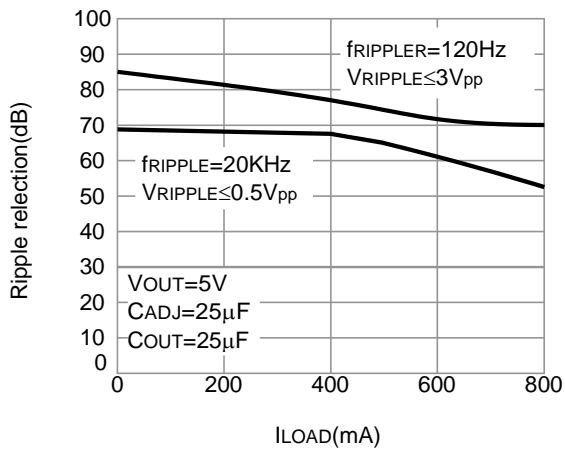

Power Dissipation VS Ambient Temperature(SOT-223)

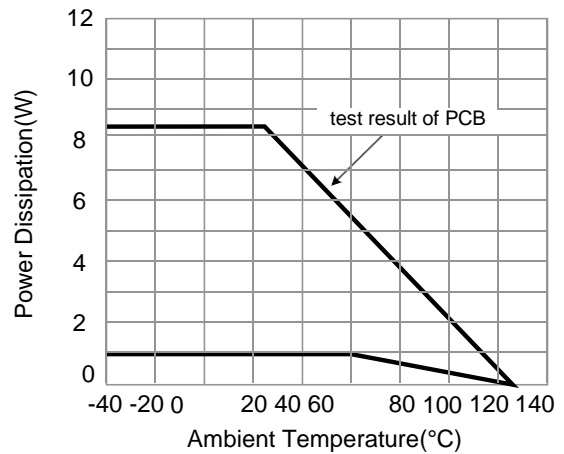

Power Dissipation VS Ambient Temperature(TO-252)

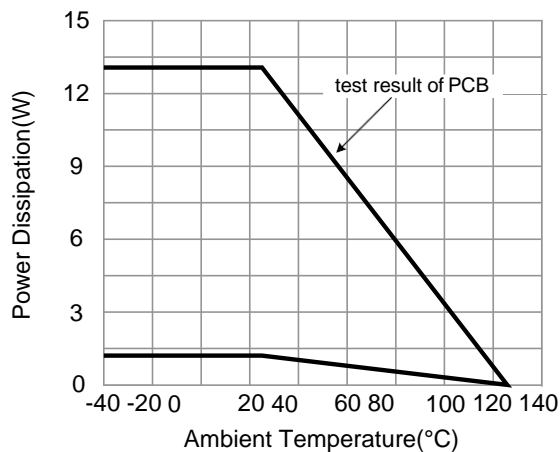

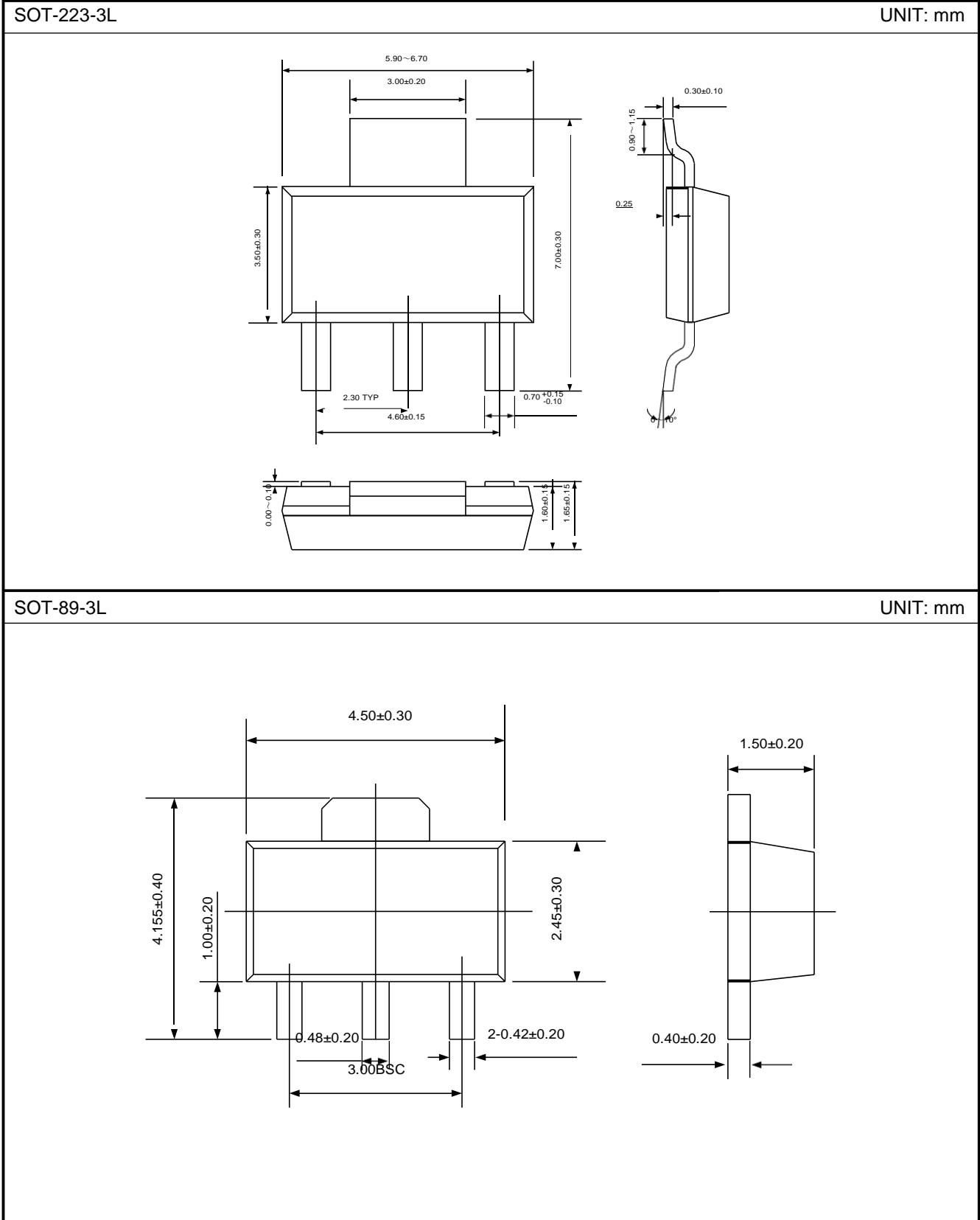

Looking for pricing, stock, or lifecycle information?

Click below to explore more details on WIN SOURCE:

- [View LD1117-5.0 on WIN SOURCE](#)
- [NXP / Nexperia Information](#)

Optimize Your Supply Chain with WIN SOURCE Solutions

- ✓ Global Sourcing Solution
- ✓ Obsolete Management
- ✓ Cost Control Management
- ✓ Shortage Management
- ✓ Alternative Solution
- ✓ Excess Inventory Management