



# THE DATASHEET OF LIS331DLFTR





# LIS331DLF

## MEMS digital output motion sensor ultra low-power high performance 3-axes “nano” accelerometer

### Features

- Wide supply voltage, 2.16 V to 3.6 V
- Low voltage compatible IOs, 1.8 V
- Ultra low-power mode consumption down to 10  $\mu$ A
- $\pm 2g/\pm 4g/\pm 8g$  dynamically selectable full-scale
- I<sup>2</sup>C/SPI digital output interface
- 6 bit resolution
- 2 independent programmable interrupt generators for free-fall and motion detection
- Sleep to wake-up function
- 6D orientation detection
- Embedded self-test
- 10000 g high shock survivability
- ECOPACK<sup>®</sup> RoHS and “Green” compliant (see [Section 8](#))

### Applications

- Display orientation
- Gaming
- User interface
- Motion activated functions
- Intelligent power saving for handheld devices
- Impact recognition and logging

### Description

The LIS331DLF is an ultra low-power high performance three axes linear accelerometer

**Table 1. Device summary**

Order codes	Temperature range [°C]	Package	Packaging
LIS331DLF	-40 to +85	LGA 16	Tray
LIS331DLFTR	-40 to +85	LGA 16	Tape and reel

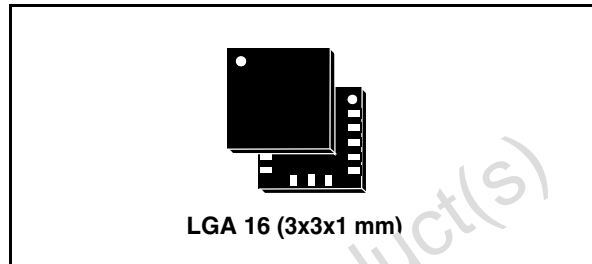

belonging to the “nano” family, with digital I<sup>2</sup>C/SPI serial interface standard output.

The device features ultra low-power operational modes that allow advanced power saving and smart sleep to wake-up functions.

The LIS331DLF has dynamically user selectable full scales of  $\pm 2g/\pm 4g/\pm 8g$  and it is capable of measuring accelerations with output data rates from 0.5 Hz to 400 Hz.

The self-test capability allows the user to check the functioning of the sensor in the final application.

The device may be configured to generate interrupt signal by inertial wake-up/free-fall events as well as by the position of the device itself. Thresholds and timing of interrupt generators are programmable by the end user on the fly.

The LIS331DLF is available in small thin plastic land grid array package (LGA) and it is guaranteed to operate over an extended temperature range from -40 °C to +85 °C.

# Contents

<b>1</b>	<b>Block diagram and pin description</b>	<b>6</b>
1.1	Block diagram	6
1.2	Pin description	6
<b>2</b>	<b>Mechanical and electrical specifications</b>	<b>8</b>
2.1	Mechanical characteristics	8
2.2	Electrical characteristics	9
2.3	Communication interface characteristics	10
2.3.1	SPI - serial peripheral interface	10
2.3.2	I2C - Inter IC control interface	11
2.4	Absolute maximum ratings	12
2.5	Terminology	13
2.5.1	Sensitivity	13
2.5.2	Zero-g level	13
2.5.3	Self-test	13
2.5.4	Sleep to wake-up	13
<b>3</b>	<b>Functionality</b>	<b>14</b>
3.1	Sensing element	14
3.2	IC interface	14
3.3	Factory calibration	14
<b>4</b>	<b>Application hints</b>	<b>15</b>
4.1	Soldering information	15
<b>5</b>	<b>Digital interfaces</b>	<b>16</b>
5.1	I2C serial interface	16
5.1.1	I2C operation	17
5.2	SPI bus interface	18
5.2.1	SPI read	19
5.2.2	SPI write	20
5.2.3	SPI read in 3-wires mode	21

<b>6</b>	<b>Register mapping</b> .....	<b>22</b>
<b>7</b>	<b>Register description</b> .....	<b>24</b>
7.1	WHO_AM_I (0Fh) .....	24
7.2	CTRL_REG1 (20h) .....	24
7.3	CTRL_REG2 (21h) .....	25
7.4	CTRL_REG3 [Interrupt CTRL register] (22h) .....	27
7.5	CTRL_REG4 (23h) .....	27
7.6	CTRL_REG5 (24h) .....	28
7.7	HP_FILTER_RESET (25h) .....	28
7.8	REFERENCE (26h) .....	28
7.9	STATUS_REG (27h) .....	29
7.10	OUT_X (29) .....	29
7.11	OUT_Y (2Bh) .....	29
7.12	OUT_Z (2Dh) .....	30
7.13	INT1_CFG (30h) .....	30
7.14	INT1_SRC (31h) .....	31
7.15	INT1_THS (32h) .....	31
7.16	INT1_DURATION (33h) .....	31
7.17	INT2_CFG (34h) .....	32
7.18	INT2_SRC (35h) .....	33
7.19	INT2_THS (36h) .....	33
7.20	INT2_DURATION (37h) .....	34
<b>8</b>	<b>Package information</b> .....	<b>35</b>
<b>9</b>	<b>Revision history</b> .....	<b>36</b>

## List of tables

Table 1.	Device summary	1
Table 2.	Pin description	6
Table 3.	Mechanical characteristics @ Vdd = 2.5 V, T = 25 °C unless otherwise noted	7
Table 4.	Electrical characteristics @ Vdd = 2.5 V, T = 25 °C unless otherwise noted	8
Table 5.	SPI slave timing values	9
Table 6.	I2C slave timing values	10
Table 7.	Absolute maximum ratings	11
Table 8.	Serial interface pin description	15
Table 9.	Serial interface pin description	15
Table 10.	SAD+Read/Write patterns	16
Table 11.	Transfer when master is writing one byte to slave	16
Table 12.	Transfer when master is writing multiple bytes to slave:	17
Table 13.	Transfer when master is receiving (reading) one byte of data from slave	17
Table 14.	Transfer when Master is receiving (reading) multiple bytes of data from slave	17
Table 15.	Register address map	21
Table 16.	WHO_AM_I register	23
Table 17.	CTRL_REG1 register	23
Table 18.	CTRL_REG1 description	23
Table 19.	Power mode and low-power output data rate configurations	24
Table 20.	Normal-mode output data rate configurations and low-pass cut-off frequencies	24
Table 21.	CTRL_REG2 register	24
Table 22.	CTRL_REG2 description	24
Table 23.	High-pass filter mode configuration	25
Table 24.	High-pass filter cut-off frequency configuration	25
Table 25.	CTRL_REG3 register	26
Table 26.	CTRL_REG3 description	26
Table 27.	Data signal on INT 1 and INT 2 pad	26
Table 28.	CTRL_REG4 register	26
Table 29.	CTRL_REG4 description	26
Table 30.	CTRL_REG5 register	27
Table 31.	CTRL_REG5 description	27
Table 32.	REFERENCE register	27
Table 33.	REFERENCE description	27
Table 34.	STATUS_REG register	28
Table 35.	STATUS_REG description	28
Table 36.	INT1_CFG register	29
Table 37.	INT1_CFG description	29
Table 38.	Interrupt 1 source configurations	29
Table 39.	INT1_SRC register	30
Table 40.	INT1_SRC description	30
Table 41.	INT1_THS register	30
Table 42.	INT1_THS description	30
Table 43.	INT1_DURATION register	30
Table 44.	INT2_DURATION description	31
Table 45.	INT2_CFG register	31
Table 46.	INT2_CFG description	31
Table 47.	Interrupt mode configuration	31
Table 48.	INT2_SRC register	32

---

Table 49.	INT2_SRC description .....	32
Table 50.	INT2_THS register .....	32
Table 51.	INT2_THS description .....	32
Table 52.	INT2_DURATION register .....	33
Table 53.	INT2_DURATION description .....	33
Table 54.	Document revision history .....	35

Obsolete Product(s) - Obsolete Product(s)

## List of figures

Figure 1.	Block diagram . . . . .	5
Figure 2.	Pin connection . . . . .	5
Figure 3.	SPI slave timing diagram (2). . . . .	9
Figure 4.	I2C Slave timing diagram . . . . .	10
Figure 5.	LIS331DLF electrical connection . . . . .	14
Figure 6.	Read and write protocol . . . . .	18
Figure 7.	SPI read protocol . . . . .	18
Figure 8.	Multiple bytes SPI read protocol (2 bytes example) . . . . .	19
Figure 9.	SPI write protocol . . . . .	19
Figure 10.	Multiple bytes SPI write protocol (2 bytes example) . . . . .	20
Figure 11.	SPI read protocol in 3-wires mode . . . . .	20
Figure 12.	LGA16: Mechanical data and package dimensions . . . . .	34

# 1 Block diagram and pin description

## 1.1 Block diagram

Figure 1. Block diagram

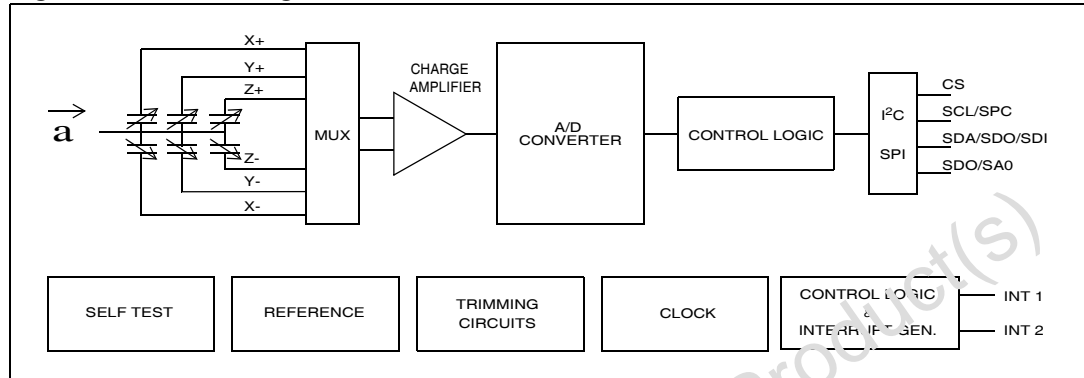

## 1.2 Pin description

Figure 2. Pin connection

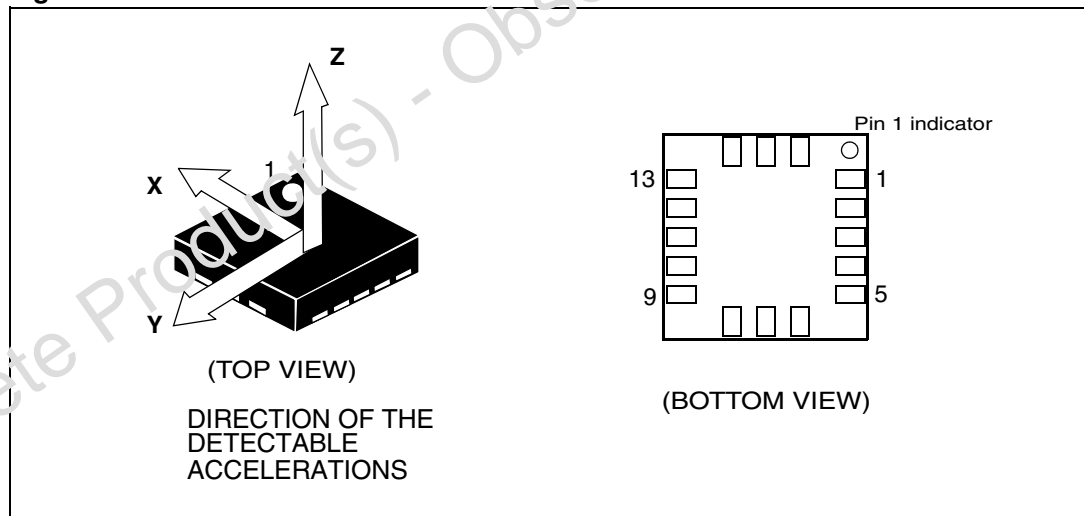

**Table 2. Pin description**

Pin#	Name	Function
1	Vdd_IO	Power supply for I/O pins
2	NC	Not connected
3	NC	Not connected
4	SCL SPC	I <sup>2</sup> C serial clock (SCL) SPI serial port clock (SPC)
5	GND	0 V supply
6	SDA SDI SDO	I <sup>2</sup> C serial data (SDA) SPI serial data input (SDI) 3-wire interface serial data output (SDO)
7	SDO SA0	SPI serial data output (SDO) I <sup>2</sup> C less significant bit of the device address (SA0)
8	CS	SPI enable I <sup>2</sup> C/SPI mode selection (1: I <sup>2</sup> C mode; 0: SPI enabled)
9	INT 2	Inertial interrupt 2
10	Reserved	Connect to GND
11	INT 1	Inertial interrupt 1
12	GND	0 V supply
13	GND	0 V supply
14	Vdd	Power supply
15	Reserved	Connect to Vdd
16	GND	0 V supply

## 2 Mechanical and electrical specifications

### 2.1 Mechanical characteristics

**Table 3. Mechanical characteristics @ Vdd = 2.5 V, T = 25 °C unless otherwise noted <sup>(1)</sup>**

Symbol	Parameter	Test conditions	Min.	Typ. <sup>(2)</sup>	Max.	Unit
FS	Measurement range <sup>(3)</sup>	FS bit set to 00		±2.0		g
		FS bit set to 01		±4.0		
		FS bit set to 11		±8.0		
So	Sensitivity	FS bit set to 00 6 bit representation		16		LSB/g
		FS bit set to 01 6 bit representation		8		
		FS bit set to 11 6 bit representation		4		
Dres	Device resolution	FS bit set to 00 ODR = 50 Hz		62.5		mg
TCSO	Sensitivity change vs temperature	FS bit set to 00		±0.01		%/°C
TyOff	Typical zero-g level offset accuracy <sup>(4),(5)</sup>	FS bit set to 00		±60		mg
TCOff	Zero-g level change vs temperature	Max delta from 25°C		±0.5		mg/°C
Vst	Self-test output change <sup>(6),(7),(8)</sup>	FS bit set to 00 X axis	1	5	8	LSb
		FS bit set to 00 Y axis	-1	-5	-8	LSb
		FS bit set to 00 Z axis	1	5	8	LSb
Toj	Operating temperature range		-40		+85	°C
Wn	Product weight			20		mgram

1. The product is factory calibrated at 2.5 V. The operational power supply range is from 2.16 V to 3.6 V.
2. Typical specifications are not guaranteed
3. Verified by wafer level test and measurement of initial offset and sensitivity
4. Typical zero-g level offset value after MSL3 preconditioning
5. Offset can be eliminated by enabling the built-in high pass filter
6. The sign of "Self-test output change" is defined by CTRL\_REG4 STsign bit ([Table 28](#)), for all axes.
7. Self-test output changes with the power supply. "Self-test output change" is defined as  $OUTPUT[LSb]_{(CTRL\_REG4\ ST\ bit=1)} - OUTPUT[LSb]_{(CTRL\_REG4\ ST\ bit=0)}$ . 1LSb=4g/64 at 6 bit representation, ±2 g full-scale
8. Output data reach 99% of final value after 1/ODR+1 ms when enabling Self-test mode, due to device filtering

## 2.2 Electrical characteristics

**Table 4. Electrical characteristics @ Vdd = 2.5 V, T = 25 °C unless otherwise noted <sup>(1)</sup>**

Symbol	Parameter	Test conditions	Min.	Typ. <sup>(2)</sup>	Max.	Unit
Vdd	Supply voltage		2.16	2.5	3.6	V
Vdd_IO	I/O pins supply voltage <sup>(3)</sup>		1.71		Vdd+0.1	V
Idd	Current consumption in normal mode			250		µA
IddLP	Current consumption in low-power mode			10		µA
IddPdn	Current consumption in power-down mode			1		µA
VIH	Digital high level input voltage		0.8*Vdd_IO			V
VIL	Digital low level input voltage				0.2*Vdd_IO	V
VOH	High level output voltage		0.9*Vdd_IO			V
VOL	Low level output voltage				0.1*Vdd_IO	V
ODR	Output data rate in normal mode	DR bit set to 00		50		Hz
		DR bit set to 01		100		
		DR bit set to 10		400		
ODR <sub>LP</sub>	Output data rate in low-power mode	PM bit set to 010		0.5		Hz
		PM bit set to 011		1		
		PM bit set to 100		2		
		PM bit set to 101		5		
		PM bit set to 110		10		
BW	System bandwidth <sup>(4)</sup>			ODR/2		Hz
Ton	Turn on time <sup>(5)</sup>	ODR = 100 Hz		1/ODR+1ms		s
Top	Operating temperature range		-40		+85	°C

1. The product is factory calibrated at 2.5 V. The operational power supply range is from 2.16 V to 3.6 V.
2. Typical specification are not guaranteed
3. It is possible to remove Vdd maintaining Vdd\_IO without blocking the communication busses, in this condition the measurement chain is powered off.
4. Refer to [Table 20](#) for filter cut-off frequency
5. Time to obtain valid data after exiting power-down mode

## 2.3 Communication interface characteristics

### 2.3.1 SPI - serial peripheral interface

Subject to general operating conditions for Vdd and Top.

**Table 5. SPI slave timing values**

Symbol	Parameter	Value <sup>(1)</sup>		Unit
		Min.	Max.	
tc(SPC)	SPI clock cycle	100		ns
fc(SPC)	SPI clock frequency		10	MHz
tsu(CS)	CS setup time	6		ns
th(CS)	CS hold time	8		
tsu(SI)	SDI input setup time	5		
th(SI)	SDI input hold time	15		
tv(SO)	SDO valid output time		50	
th(SO)	SDO output hold time	9		
tdis(SO)	SDO output disable time		50	

**Figure 3. SPI slave timing diagram <sup>(2)</sup>**

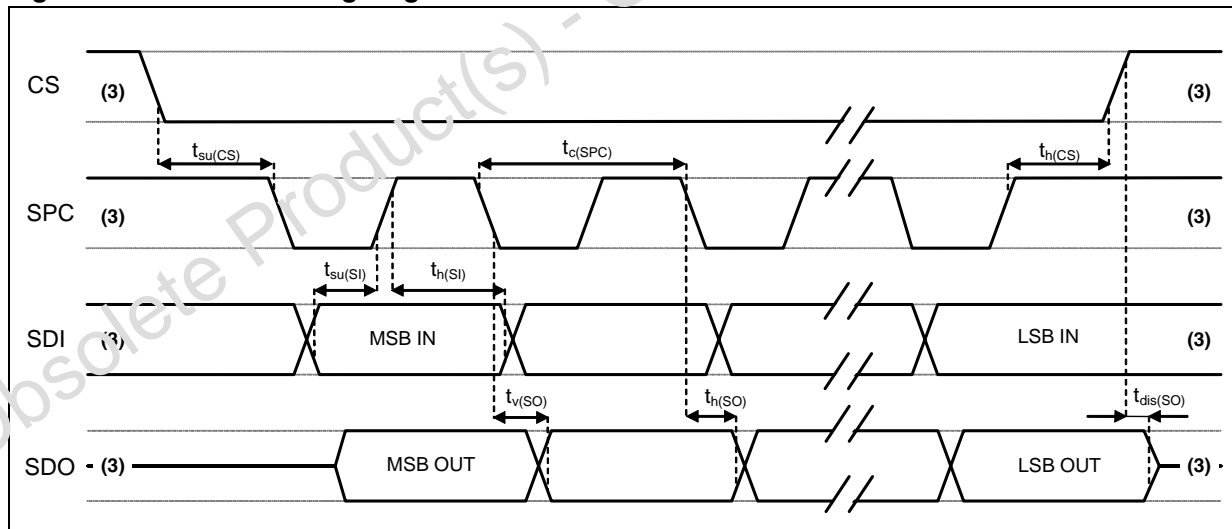

1. Values are guaranteed at 10 MHz clock frequency for SPI with both 4 and 3 wires, based on characterization results, not tested in production
2. Measurement points are done at 0.2·Vdd\_IO and 0.8·Vdd\_IO, for both Input and output port
3. When no communication is on-going, data on CS, SPC, SDI and SDO are driven by internal pull-up resistors

### 2.3.2 I<sup>2</sup>C - Inter IC control interface

Subject to general operating conditions for Vdd and top.

**Table 6. I<sup>2</sup>C slave timing values**

Symbol	Parameter	I <sup>2</sup> C standard mode (1)		I <sup>2</sup> C fast mode (1)		Unit
		Min	Max	Min	Max	
f <sub>(SCL)</sub>	SCL clock frequency	0	100	0	400	KHz
t <sub>w(SCLL)</sub>	SCL clock low time	4.7		1.3		μs
t <sub>w(SCLH)</sub>	SCL clock high time	4.0		0.6		
t <sub>su(SDA)</sub>	SDA setup time	250		100		ns
t <sub>h(SDA)</sub>	SDA data hold time	0.01	3.45	0.01	0.9	μs
t <sub>r(SDA)</sub> t <sub>r(SCL)</sub>	SDA and SCL rise time		1000	20 + 0.1C <sub>b</sub> (2)	300	ns
t <sub>f(SDA)</sub> t <sub>f(SCL)</sub>	SDA and SCL fall time		300	20 + 0.1C <sub>b</sub> (2)	300	
t <sub>h(ST)</sub>	START condition hold time	4		0.6		μs
t <sub>su(SR)</sub>	Repeated START condition setup time	4.7		0.6		
t <sub>su(SP)</sub>	STOP condition setup time			0.6		
t <sub>w(SP:SR)</sub>	Bus free time between STOP and START condition	4.7		1.3		

1. Data based on standard I<sup>2</sup>C protocol requirement, not tested in production
2. C<sub>b</sub> = total capacitance of one bus line in pF

**Figure 4. I<sup>2</sup>C Slave timing diagram (a)**

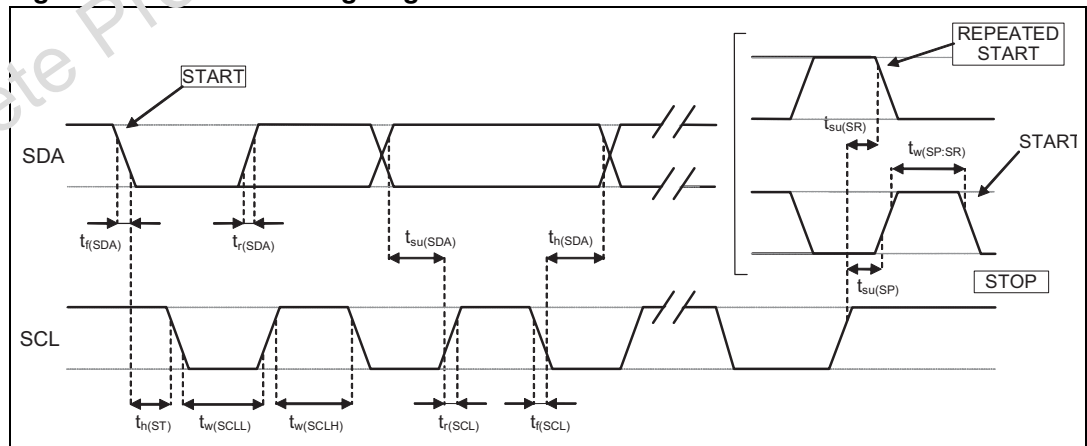

a. Measurement points are done at 0.2·Vdd\_IO and 0.8·Vdd\_IO, for both port

## 2.4 Absolute maximum ratings

Stresses above those listed as “absolute maximum ratings” may cause permanent damage to the device. This is a stress rating only and functional operation of the device under these conditions is not implied. Exposure to maximum rating conditions for extended periods may affect device reliability.

**Table 7. Absolute maximum ratings**

Symbol	Ratings	Maximum value	Unit
V <sub>dd</sub>	Supply voltage	-0.3 to 6	V
V <sub>dd_IO</sub>	I/O pins supply voltage	-0.3 to 6	V
V <sub>in</sub>	Input voltage on any control pin (CS, SCL/SPC, SDA/SDI/SDO, SDO/SA0)	-0.3 to V <sub>dd_IO</sub> +0.3	V
A <sub>POW</sub>	Acceleration (any axis, powered, V <sub>dd</sub> = 2.5 V)	3000 g for 0.5 ms 10000 g for 0.1 ms	
A <sub>UNP</sub>	Acceleration (any axis, unpowered)	3000 g for 0.5 ms 10000 g for 0.1 ms	
T <sub>OP</sub>	Operating temperature range	-40 to +85	°C
T <sub>STG</sub>	Storage temperature range	-40 to +125	°C
ESD	Electrostatic discharge protection	4 (HBM)	kV
		1.5 (CDM)	kV
		200 (MM)	V

**Note:** Supply voltage on any pin should never exceed 6.0 V



This is a mechanical shock sensitive device, improper handling can cause permanent damages to the part



This is an ESD sensitive device, improper handling can cause permanent damages to the part

## 2.5 Terminology

### 2.5.1 Sensitivity

Sensitivity describes the gain of the sensor and can be determined e.g. by applying 1 *g* acceleration to it. As the sensor can measure DC accelerations this can be done easily by pointing the axis of interest towards the center of the earth, noting the output value, rotating the sensor by 180 degrees (pointing to the sky) and noting the output value again. By doing so,  $\pm 1$  *g* acceleration is applied to the sensor. Subtracting the larger output value from the smaller one, and dividing the result by 2, leads to the actual sensitivity of the sensor. This value changes very little over temperature and also time. The Sensitivity Tolerance describes the range of Sensitivities of a large population of sensors.

### 2.5.2 Zero-*g* level

Zero-*g* level offset (TyOff) describes the deviation of an actual output signal from the ideal output signal if no acceleration is present. A sensor in a steady state on a horizontal surface will measure 0 *g* in X axis and 0 *g* in Y axis whereas the Z axis will measure 1 *g*. The output is ideally in the middle of the dynamic range of the sensor (content of OUT registers 00h, data expressed as 2's complement number). A deviation from ideal value in this case is called Zero-*g* offset. Offset is to some extent a result of stress to MEMS sensor and therefore the offset can slightly change after mounting the sensor onto a printed circuit board or exposing it to extensive mechanical stress. Offset changes little over temperature, see "Zero-*g* level change vs. temperature". The Zero-*g* level tolerance (TyOff) describes the Standard deviation of the range of Zero-*g* levels of a population of sensors.

### 2.5.3 Self-test

Self-test allows to check the sensor functionality without moving it. The Self-test function is off when the self-test bit (ST) of CTRL\_REG4 (control register 4) is programmed to '0'. When the self-test bit of CTRL\_REG4 is programmed to '1' an actuation force is applied to the sensor, simulating a definite input acceleration. In this case the sensor outputs will exhibit a change in their DC levels which are related to the selected full scale through the device sensitivity. When self-test is activated, the device output level is given by the algebraic sum of the signals produced by the acceleration acting on the sensor and by the electrostatic test-force. If the output signals change within the amplitude specified inside [Table 3](#), then the sensor is working properly and the parameters of the interface chip are within the defined specifications.

### 2.5.4 Sleep to wake-up

The "sleep to wake-up" function, in conjunction with low-power mode, allows to further reduce the system power consumption and develop new smart applications.

LIS331DLF may be set in a low-power operating mode, characterized by lower data rates refreshments. In this way the device, even if sleeping, keep on sensing acceleration and generating interrupt requests.

When the "sleep to wake-up" function is activated, LIS331DLF is able to automatically wake-up as soon as the interrupt event has been detected, increasing the output data rate and bandwidth.

With this feature the system may be efficiently switched from low-power mode to full-performance depending on user-selectable positioning and acceleration events, thus ensuring power saving and flexibility.

## 3 Functionality

The LIS331DLF is a “nano”, low-power, digital output 3-axis linear accelerometer packaged in a LGA package. The complete device includes a sensing element and an IC interface able to take the information from the sensing element and to provide a signal to the external world through an I<sup>2</sup>C/SPI serial interface.

### 3.1 Sensing element

A proprietary process is used to create a surface micro-machined accelerometer. The technology allows to carry out suspended silicon structures which are attached to the substrate in a few points called anchors and are free to move in the direction of the sensed acceleration. To be compatible with the traditional packaging techniques a cap is placed on top of the sensing element to avoid blocking the moving parts during the moulding phase of the plastic encapsulation.

When an acceleration is applied to the sensor the proof mass displaces from its nominal position, causing an imbalance in the capacitive half-bridge. This imbalance is measured using charge integration in response to a voltage pulse applied to the capacitor.

At steady state the nominal value of the capacitors are few pF and when an acceleration is applied the maximum variation of the capacitive load is in the fF range.

### 3.2 IC interface

The complete measurement chain is composed by a low-noise capacitive amplifier which converts the capacitive unbalancing of the MEMS sensor into an analog voltage that is finally available to the user by an analog-to-digital converter.

The acceleration data may be accessed through an I<sup>2</sup>C/SPI interface thus making the device particularly suitable for direct interfacing with a microcontroller.

The LIS331DLF features a data-ready signal (RDY) which indicates when a new set of measured acceleration data is available thus simplifying data synchronization in the digital system that uses the device.

The LIS331DLF may also be configured to generate an inertial wake-up and free-fall interrupt signal accordingly to a programmed acceleration event along the enabled axes. Both Free-Fall and Wake-Up can be available simultaneously on two different pins.

### 3.3 Factory calibration

The IC interface is factory calibrated for sensitivity (S<sub>0</sub>) and Zero-g level (T<sub>yOff</sub>).

The trimming values are stored inside the device in a non volatile memory. Any time the device is turned on, the trimming parameters are downloaded into the registers to be used during the active operation. This allows to use the device without further calibration.

## 4 Application hints

**Figure 5. LIS331DLF electrical connection**

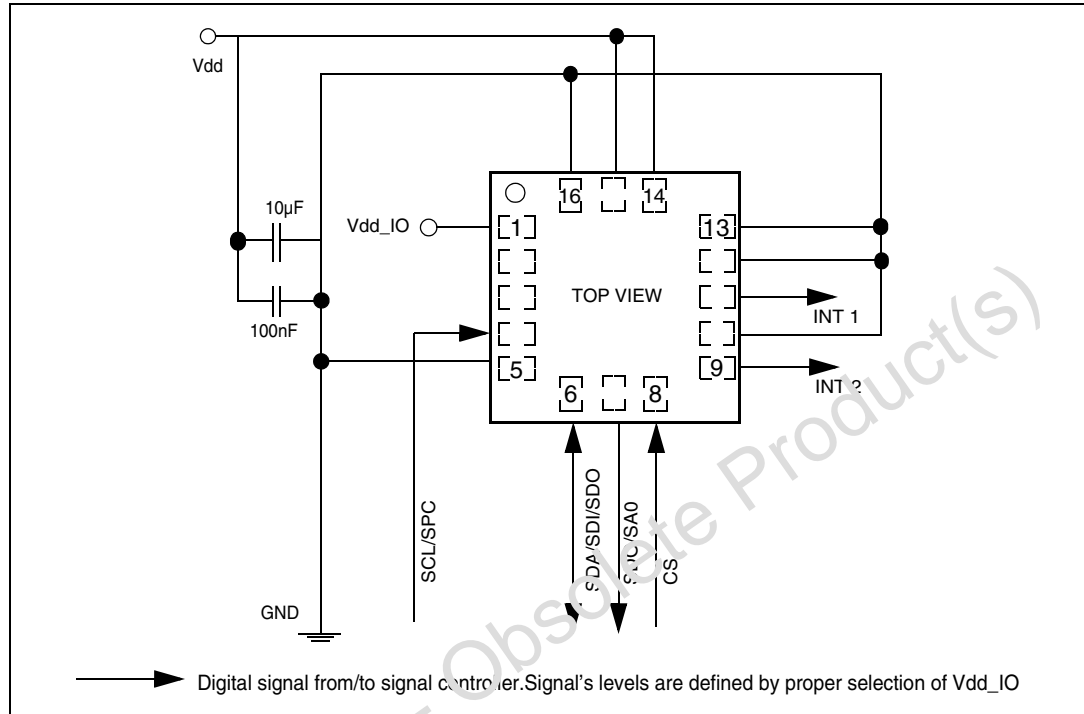

The device core is supplied through Vdd line while the I/O pads are supplied through Vdd\_IO line. Power supply decoupling capacitors (100 nF ceramic, 10 µF Aluminum) should be placed as near as possible to the pin 14 of the device (common design practice).

All the voltage and ground supplies must be present at the same time to have proper behavior of the IC (refer to *Figure 5*). It is possible to remove Vdd maintaining Vdd\_IO without blocking the communication bus, in this condition the measurement chain is powered off.

The functionality of the device and the measured acceleration data is selectable and accessible through the I<sup>2</sup>C or SPI interfaces. When using the I<sup>2</sup>C, CS must be tied high.

The functions, the threshold and the timing of the two interrupt pins (INT 1 and INT 2) can be completely programmed by the user through the I<sup>2</sup>C/SPI interface.

### 4.1 Soldering information

The LGA package is compliant with the ECOPACK<sup>®</sup>, RoHS and “Green” standard. It is qualified for soldering heat resistance according to JEDEC J-STD-020C.

Leave “pin 1 indicator” unconnected during soldering.

Land pattern and soldering recommendations are available at [www.st.com](http://www.st.com).

## 5 Digital interfaces

The registers embedded inside the LIS331DLF may be accessed through both the I<sup>2</sup>C and SPI serial interfaces. The latter may be SW configured to operate either in 3-wire or 4-wire interface mode.

The serial interfaces are mapped onto the same pads. To select/exploit the I<sup>2</sup>C interface, CS line must be tied high (i.e. connected to Vdd\_IO).

**Table 8. Serial interface pin description**

Pin name	Pin description
CS	SPI enable I <sup>2</sup> C/SPI mode selection (1: I <sup>2</sup> C mode; 0: SPI enabled)
SCL	I <sup>2</sup> C serial clock (SCL)
SPC	SPI serial port clock (SPC)
SDA	I <sup>2</sup> C serial data (SDA)
SDI	SPI serial data input (SDI)
SDO	3-wire interface serial data output (SDO)
SA0	I <sup>2</sup> C less significant bit of the device address (SA0)
SDO	SPI serial data output (SDO)

### 5.1 I<sup>2</sup>C serial interface

The LIS331DLF I<sup>2</sup>C is a bus slave. The I<sup>2</sup>C is employed to write data into registers whose content can also be read back.

The relevant I<sup>2</sup>C terminology is given in the table below.

**Table 9. Serial interface pin description**

Term	Description
Transmitter	The device which sends data to the bus
Receiver	The device which receives data from the bus
Master	The device which initiates a transfer, generates clock signals and terminates a transfer
Slave	The device addressed by the master

There are two signals associated with the I<sup>2</sup>C bus: the serial clock line (SCL) and the serial data line (SDA). The latter is a bidirectional line used for sending and receiving the data to/from the interface. Both the lines are connected to Vdd\_IO through a pull-up resistor embedded inside the LIS331DLF. When the bus is free both the lines are high.

The I<sup>2</sup>C interface is compliant with fast mode (400 kHz) I<sup>2</sup>C standards as well as with the normal mode.

### 5.1.1 I<sup>2</sup>C operation

The transaction on the bus is started through a START (ST) signal. A START condition is defined as a HIGH to LOW transition on the data line while the SCL line is held HIGH. After this has been transmitted by the Master, the bus is considered busy. The next byte of data transmitted after the start condition contains the address of the slave in the first 7 bits and the eighth bit tells whether the Master is receiving data from the slave or transmitting data to the slave. When an address is sent, each device in the system compares the first seven bits after a start condition with its address. If they match, the device considers itself addressed by the Master.

The slave address (SAD) associated to the LIS331DLF is 010100xb. **SDO/SA0** pad can be used to modify less significant bit of the device address. If SA0 pad is connected to voltage supply, LSb is '1' (address 0101001b) else if SA0 pad is connected to ground, LSb value is '0' (address 0101000b). This solution permits to connect and address two different accelerometers to the same I<sup>2</sup>C lines.

Data transfer with acknowledge is mandatory. The transmitter must release the SDA line during the acknowledge pulse. The receiver must then pull the data line LOW so that it remains stable low during the HIGH period of the acknowledge clock pulse. A receiver which has been addressed is obliged to generate an acknowledge after each byte of data received.

The I<sup>2</sup>C embedded inside the LIS331DLF behaves like a slave device and the following protocol must be adhered to. After the start condition (ST) a slave address is sent, once a slave acknowledge (SAK) has been returned, a 8-bit sub-address (SUB) is transmitted: the 7 LSb represent the actual register address while the MSB enables address auto increment. If the MSb of the SUB field is '1', the SUB (register address) is automatically increased to allow multiple data read/write.

The slave address is completed with a Read/Write bit. If the bit was '1' (Read), a repeated START (SR) condition must be issued after the two sub-address bytes; if the bit is '0' (Write) the Master will transmit to the slave with direction unchanged. [Table 10](#) explains how the SAD+Read/Write bit pattern is composed, listing all the possible configurations.

**Table 10. SAD+Read/Write patterns**

Command	SAD[6:1]	SAD[0] = SA0	R/W	SAD+R/W
Read	010100	0	1	01010001 (51h)
Write	010100	0	0	01010000 (50h)
Read	010100	1	1	01010011 (53h)
Write	010100	1	0	01010010 (52h)

**Table 11. Transfer when master is writing one byte to slave**

Master	ST	SAD + W		SUB		DATA		SP
Slave			SAK		SAK		SAK	

**Table 12. Transfer when master is writing multiple bytes to slave:**

Master	ST	SAD + W		SUB		DATA		DATA		SP
Slave			SAK		SAK		SAK		SAK	

**Table 13. Transfer when master is receiving (reading) one byte of data from slave:**

Master	ST	SAD + W		SUB		SR	SAD + R			NMAK	SP
Slave			SAK		SAK			SAK	DATA		

**Table 14. Transfer when Master is receiving (reading) multiple bytes of data from slave:**

Master	ST	SAD+W		SUB		SR	SAD+R			MAK		MAK		NMAK	SP
Slave			SAK		SAK			SAK	DATA		DATA		DATA		

Data are transmitted in byte format (DATA). Each data transfer contains 8 bits. The number of bytes transferred per transfer is unlimited. Data is transferred with the Most Significant bit (MSb) first. If a receiver can't receive another complete byte of data until it has performed some other function, it can hold the clock line, SCL LOW to force the transmitter into a wait state. Data transfer only continues when the receiver is ready for another byte and releases the data line. If a slave receiver doesn't acknowledge the slave address (i.e. it is not able to receive because it is performing some real time function) the data line must be left HIGH by the slave. The Master can then abort the transfer. A LOW to HIGH transition on the SDA line while the SCL line is HIGH is defined as a STOP condition. Each data transfer must be terminated by the generation of a STOP (SP) condition.

In order to read multiple bytes, it is necessary to assert the most significant bit of the sub-address field. In other words, SUB(7) must be equal to 1 while SUB(6-0) represents the address of first register to be read.

In the presented communication format MAK is master acknowledge and NMAK is no master acknowledge.

## 5.2 SPI bus interface

The LIS331DLF SPI is a bus slave. The SPI allows to write and read the registers of the device.

The Serial Interface interacts with the outside world with 4 wires: **CS**, **SPC**, **SDI** and **SDO**.

**Figure 6. Read and write protocol**

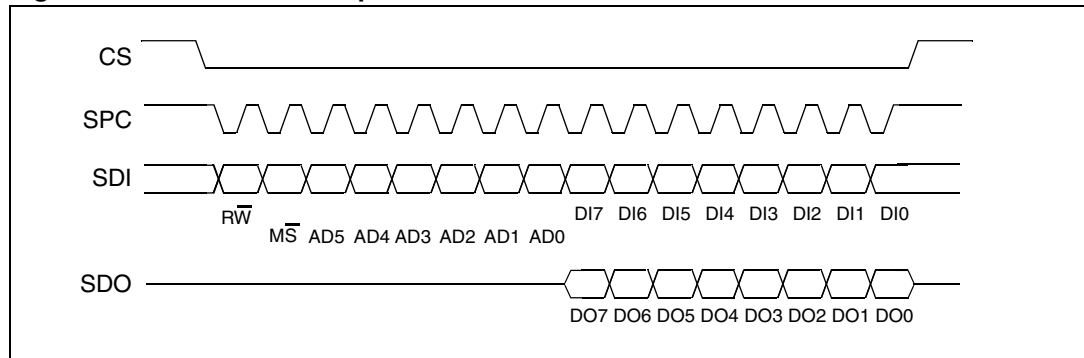

**CS** is the serial port enable and it is controlled by the SPI master. It goes low at the start of the transmission and goes back high at the end. **SPC** is the Serial Port Clock and it is controlled by the SPI master. It is stopped high when **CS** is high (no transmission). **SDI** and **SDO** are respectively the serial port data input and output. Those lines are driven at the falling edge of **SPC** and should be captured at the rising edge of **SPC**.

Both the Read Register and Write Register commands are completed in 16 clock pulses or in multiple of 8 in case of multiple bytes read/write. Bit duration is the time between two falling edges of **SPC**. The first bit (bit 0) starts at the first falling edge of **SPC** after the falling edge of **CS** while the last bit (bit 15, bit 23, ...) starts at the last falling edge of **SPC** just before the rising edge of **CS**.

**bit 0:**  $\overline{RW}$  bit. When 0, the data DI(7:0) is written into the device. When 1, the data DO(7:0) from the device is read. In latter case, the chip will drive **SDO** at the start of bit 8.

**bit 1:**  $\overline{MS}$  bit. When 0, the address will remain unchanged in multiple read/write commands. When 1, the address is auto incremented in multiple read/write commands.

**bit 2-7:** address AD(5:0). This is the address field of the indexed register.

**bit 8-15:** data DI(7:0) (write mode). This is the data that is written into the device (MSb first).

**bit 8-15:** data DO(7:0) (read mode). This is the data that is read from the device (MSb first).

In multiple read/write commands further blocks of 8 clock periods will be added. When  $\overline{MS}$  bit is '0' the address used to read/write data remains the same for every block. When  $\overline{MS}$  bit is '1' the address used to read/write data is increased at every block.

The function and the behavior of **SDI** and **SDO** remain unchanged.

### 5.2.1 SPI read

**Figure 7. SPI read protocol**

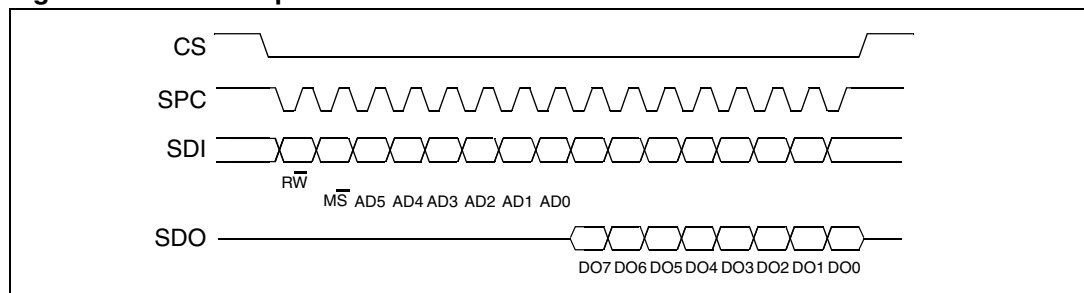

The SPI read command is performed with 16 clock pulses. Multiple byte read command is performed adding blocks of 8 clock pulses at the previous one.

**bit 0:** READ bit. The value is 1.

**bit 1:**  $\overline{MS}$  bit. When 0 do not increment address, when 1 increment address in multiple reading.

**bit 2-7:** address AD(5:0). This is the address field of the indexed register.

**bit 8-15:** data DO(7:0) (read mode). This is the data that will be read from the device (MSb first).

**bit 16-...** : data DO(...-8). Further data in multiple byte reading.

**Figure 8. Multiple bytes SPI read protocol (2 bytes example)**

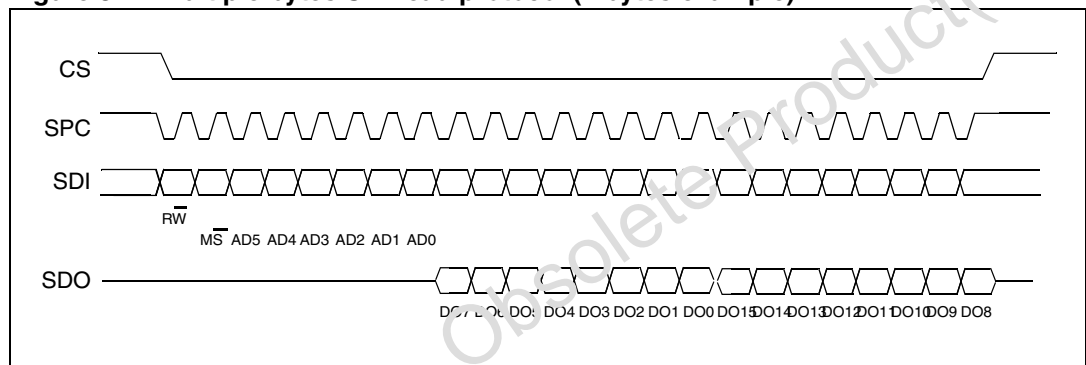

### 5.2.2 SPI write

**Figure 9. SPI write protocol**

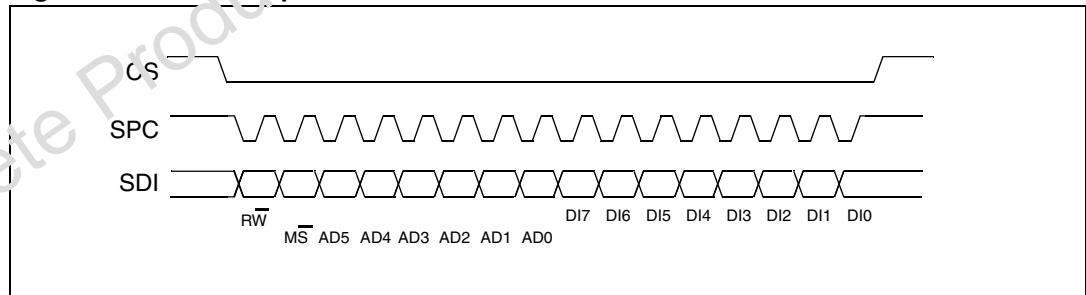

The SPI Write command is performed with 16 clock pulses. Multiple byte write command is performed adding blocks of 8 clock pulses at the previous one.

**bit 0:** WRITE bit. The value is 0.

**bit 1:**  $\overline{MS}$  bit. When 0 do not increment address, when 1 increment address in multiple writing.

**bit 2 -7:** address AD(5:0). This is the address field of the indexed register.

**bit 8-15:** data DI(7:0) (write mode). This is the data that will be written inside the device (MSb first).

**bit 16-...** : data DI(...-8). Further data in multiple byte writing.

**Figure 10. Multiple bytes SPI write protocol (2 bytes example)**

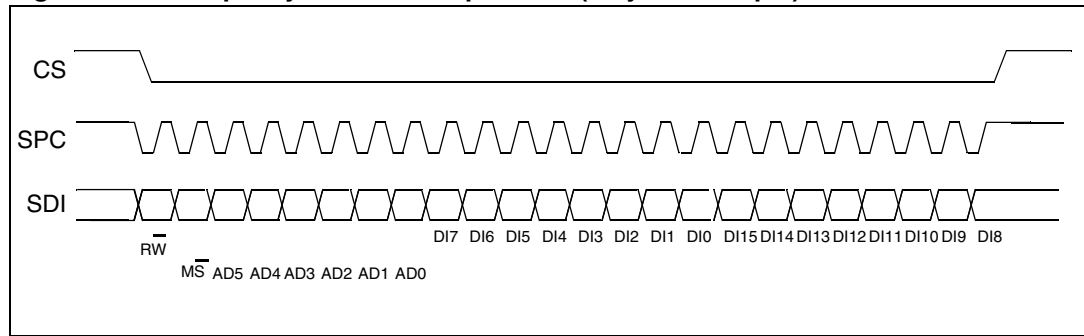

### 5.2.3 SPI read in 3-wires mode

3-wires mode is entered by setting to '1' bit SIM (SPI serial interface mode selection) in CTRL\_REG4.

**Figure 11. SPI read protocol in 3-wires mode**

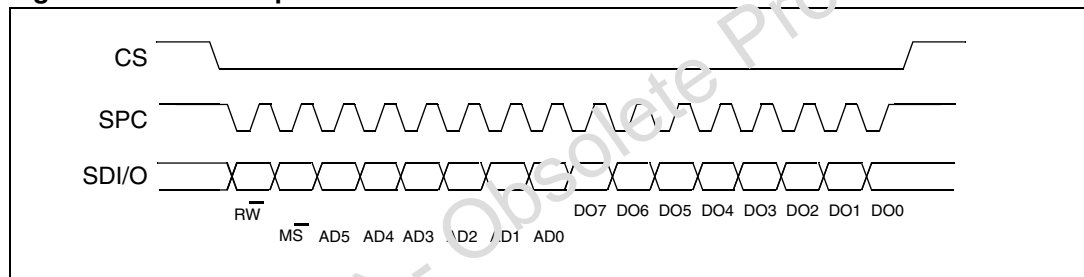

The SPI Read command is performed with 16 clock pulses:

**bit 0:** READ bit. The value is 1.

**bit 1:**  $\overline{MS}$  bit. When 0 do not increment address, when 1 increment address in multiple reading.

**bit 2-7:** address AD(5:0). This is the address field of the indexed register.

**bit 8-15:** data DO(7:0) (read mode). This is the data that is read from the device (MSb first).

Multiple read command is also available in 3-wires mode.

## 6 Register mapping

The table given below provides a listing of the 8 bit registers embedded in the device and the related addresses:

**Table 15. Register address map**

Name	Type	Register address		Default	Comment
		Hex	Binary		
Reserved (do not modify)		00 - 0E			Reserved
WHO_AM_I	r	0F	000 1111	01010010	Dummy register
Reserved (do not modify)		10 - 1F			Reserved
CTRL_REG1	rw	20	010 0000	00000111	
CTRL_REG2	rw	21	010 0001	00000000	
CTRL_REG3	rw	22	010 0010	00000000	
CTRL_REG4	rw	23	010 0011	00000000	
CTRL_REG5	rw	24	010 0100	00000000	
HP_FILTER_RESET	r	25	010 0101		Dummy register
REFERENCE	rw	26	010 0110	00000000	
STATUS_REG	r	27	010 0111	00000000	
--	r	28	010 1000	00000000	Not used
OUT_X	r	29	010 1001	output	
--	r	2A	010 1010	00000000	Not used
OUT_Y	r	2B	010 1011	output	
--	r	2C	010 1100	00000000	Not used
OUT_Z	r	2D	010 1101	output	
Reserved (do not modify)		2E - 2F			Reserved
INT1_CFG	rw	30	011 0000	00000000	
INT1_SOURCE	r	31	011 0001	00000000	
INT1_THS	rw	32	011 0010	00000000	
INT1_DURATION	rw	33	011 0011	00000000	
INT2_CFG	rw	34	011 0100	00000000	
INT2_SOURCE	r	35	011 0101	00000000	
INT2_THS	rw	36	011 0110	00000000	
INT2_DURATION	rw	37	011 0111	00000000	
Reserved (do not modify)		38 - 3F			Reserved

Registers marked as *Reserved* must not be changed. The writing to those registers may cause permanent damages to the device.

The content of the registers that are loaded at boot should not be changed. They contain the factory calibration values. Their content is automatically restored when the device is powered-up.

Obsolete Product(s) - Obsolete Product(s)

## 7 Register description

The device contains a set of registers which are used to control its behavior and to retrieve acceleration data. The registers address, made of 7 bits, is used to identify them and to write the data through serial interface.

### 7.1 WHO\_AM\_I (0Fh)

**Table 16. WHO\_AM\_I register**

0	1	0	1	0	0	1	0
---	---	---	---	---	---	---	---

Device identification register.

This register contains the device identifier that for LIS331DLF is set to 52h.

### 7.2 CTRL\_REG1 (20h)

**Table 17. CTRL\_REG1 register**

PM2	PM1	PM0	DR1	DR0	Zen	Yen	Xen
-----	-----	-----	-----	-----	-----	-----	-----

**Table 18. CTRL\_REG1 description**

PM2 - PM0	Power mode selection. Default value: 000 (000: Power-down; Others: refer to <a href="#">Table 19</a> )
DR1, DR0	Data rate selection. Default value: 00 (00:50 Hz; Others: refer to <a href="#">Table 20</a> )
Zen	Z axis enable. Default value: 1 (0: Z axis disabled; 1: Z axis enabled)
Yen	Y axis enable. Default value: 1 (0: Y axis disabled; 1: Y axis enabled)
Xen	X axis enable. Default value: 1 (0: X axis disabled; 1: X axis enabled)

**PM** bits allow to select between power-down and two operating active modes. The device is in power-down mode when PD bits are set to “000” (default value after boot). [Table 19](#) shows all the possible power mode configurations and respective output data rates. Output data in the low-power modes are computed with low-pass filter cut-off frequency defined by DR1, DR0 bits.

**DR** bits, in the normal-mode operation, select the data rate at which acceleration samples are produced. In low-power mode they define the output data resolution. [Table 20](#) shows all the possible configuration for DR1 and DR0 bits.

**Table 19. Power mode and low-power output data rate configurations**

PM2	PM1	PM0	Power mode selection	Output data rate [Hz] ODR <sub>LP</sub>
0	0	0	Power-down	--
0	0	1	Normal mode	ODR
0	1	0	Low-power	0.5
0	1	1	Low-power	1
1	0	0	Low-power	2
1	0	1	Low-power	5
1	1	0	Low-power	10

**Table 20. Normal-mode output data rate configurations and low-pass cut-off frequencies**

DR1 <sup>(1)</sup>	DR0 <sup>(1)</sup>	Output data rate [Hz] ODR	Low-pass filter cut-off frequency [Hz]
0	0	50	37
0	1	100	74
1	0	400	292

1. "11" bit configuration is not allowed and may cause incorrect device functionality.

### 7.3 CTRL\_REG2 (21h)

**Table 21. CTRL\_REG2 register**

BOOT	HPM1	HPM0	FDS	HPen2	HPen1	HPCF1	HPCF0
------	------	------	-----	-------	-------	-------	-------

**Table 22. CTRL\_REG2 description**

BOOT	Reboot memory content. Default value: 0 (0: normal mode; 1: reboot memory content)
HPM1, HPM0	High pass filter mode selection. Default value: 00 (00: normal mode; Others: refer to <a href="#">Table 23</a> )
FDS	Filtered data selection. Default value: 0 (0: internal filter bypassed; 1: data from internal filter sent to output register)
HPen2	High pass filter enabled for interrupt 2 source. Default value: 0 (0: filter bypassed; 1: filter enabled)

**Table 22. CTRL\_REG2 description (continued)**

HPen1	High pass filter enabled for interrupt 1 source. Default value: 0 (0: filter bypassed; 1: filter enabled)
HPCF1, HPCF0	High pass filter cut-off frequency configuration. Default value: 00 (00: HPC=8; 01: HPC=16; 10: HPC=32; 11: HPC=64)

**BOOT** bit is used to refresh the content of internal registers stored in the flash memory block. At the device power up the content of the flash memory block is transferred to the internal registers related to trimming functions to permit a good behavior of the device itself. If for any reason the content of trimming registers was changed it is sufficient to use this bit to restore correct values. When **BOOT** bit is set to '1' the content of internal flash is copied inside corresponding internal registers and it is used to calibrate the device. These values are factory trimmed and they are different for every accelerometer. They permit a good behavior of the device and normally they have not to be changed. At the end of the boot process the **BOOT** bit is set again to '0'.

**Table 23. High-pass filter mode configuration**

HPM1	HPM0	High-pass filter mode
0	0	Normal mode (reset reading HP_RESET_FILTER)
0	1	Reference signal for filtering
1	0	Normal mode (reset reading HP_RESET_FILTER)

**HPCF[1:0]**. These bits are used to configure high-pass filter cut-off frequency  $f_t$  which is given by:

$$f_t = \ln\left(1 - \frac{1}{\text{HPC}}\right) \cdot \frac{f_s}{2\pi}$$

The equation can be simplified to the following approximated equation:

$$f_t = \frac{f_s}{6 \cdot \text{HPC}}$$

**Table 24. High-pass filter cut-off frequency configuration**

HPcoeff2,1	$f_t$ [Hz] Data rate = 50 Hz	$f_t$ [Hz] Data rate = 100 Hz	$f_t$ [Hz] Data rate = 400 Hz
00	1	2	8
01	0.5	1	4
10	0.25	0.5	2
11	0.125	0.25	1

## 7.4 CTRL\_REG3 [Interrupt CTRL register] (22h)

**Table 25. CTRL\_REG3 register**

IHL	PP_OD	LIR2	I2_CFG1	I2_CFG0	LIR1	I1_CFG1	I1_CFG0
-----	-------	------	---------	---------	------	---------	---------

**Table 26. CTRL\_REG3 description**

IHL	Interrupt active high, low. Default value: 0 (0: active high; 1: active low)
PP_OD	Push-pull/Open drain selection on interrupt pad. Default value 0. (0: push-pull; 1: open drain)
LIR2	Latch interrupt request on INT2_SRC register, with INT2_SRC register cleared by reading INT2_SRC itself. Default value: 0. (0: interrupt request not latched; 1: interrupt request latched)
I2_CFG1, I2_CFG0	Data signal on INT 2 pad control bits. Default value: 00. (see table below)
LIR1	Latch interrupt request on INT1_SRC register, with INT1_SRC register cleared by reading INT1_SRC register. Default value: 0. (0: interrupt request not latched; 1: interrupt request latched)
I1_CFG1, I1_CFG0	Data signal on INT 1 pad control bits. Default value: 00. (see table below)

**Table 27. Data signal on INT 1 and INT 2 pad**

I1(2)_CFG1	I1(2)_CFG0	INT 1(2) Pad
0	0	Interrupt 1 (2) source
0	1	Interrupt 1 source OR Interrupt 2 source
1	0	Data ready
1	1	Boot running

## 7.5 CTRL\_REG4 (23h)

**Table 28. CTRL\_REG4 register**

0	0	FS1	FS0	STsign	0	ST	SIM
---	---	-----	-----	--------	---	----	-----

**Table 29. CTRL\_REG4 description**

FS1, FS0	Full-scale selection. Default value: 00. (00: $\pm 2 g$ ; 01: $\pm 4 g$ ; 11: $\pm 8 g$ )
STsign	Self-test sign. Default value: 00. (0: self-test plus; 1 self-test minus)
ST	Self-test enable. Default value: 0. (0: self-test disabled; 1: self-test enabled)
SIM	SPI serial interface mode selection. Default value: 0. (0: 4-wire interface; 1: 3-wire interface)

## 7.6 CTRL\_REG5 (24h)

**Table 30. CTRL\_REG5 register**

0	0	0	0	0	0	TurnOn1	TurnOn0
---	---	---	---	---	---	---------	---------

**Table 31. CTRL\_REG5 description**

TurnOn1, TurnOn0	Turn-on mode selection for sleep to wake function. Default value: 00.
---------------------	---

TurnOn bits are used for turning on the **sleep to wake** function.

## 7.7 HP\_FILTER\_RESET (25h)

Dummy register. Reading at this address zeroes instantaneously the content of the internal high pass-filter. If the high pass filter is enabled all three axes are instantaneously set to 0g. This allows to overcome the settling time of the high pass filter.

## 7.8 REFERENCE (26h)

**Table 32. REFERENCE register**

Ref7	Ref6	Ref5	Ref4	Ref3	Ref2	Ref1	Ref0
------	------	------	------	------	------	------	------

**Table 33. REFERENCE description**

Ref7 - Ref0	Reference value for high-pass filter. Default value: 00h.
-------------	---

This register sets the acceleration value taken as a reference for the high-pass filter output.

When filter is turned on (at least one of FDS, HPen2, or HPen1 bit is equal to '1') and HPM bits are set to "01", filter out is generated taking this value as a reference.

## 7.9 STATUS\_REG (27h)

**Table 34. STATUS\_REG register**

ZYXOR	ZOR	YOR	XOR	ZYXDA	ZDA	YDA	XDA
-------	-----	-----	-----	-------	-----	-----	-----

**Table 35. STATUS\_REG description**

ZYXOR	X, Y and Z axis data overrun. Default value: 0 (0: no overrun has occurred; 1: new data has overwritten the previous one before it was read)
ZOR	Z axis data overrun. Default value: 0 (0: no overrun has occurred; 1: a new data for the Z-axis has overwritten the previous one)
YOR	Y axis data overrun. Default value: 0 (0: no overrun has occurred; 1: a new data for the Y-axis has overwritten the previous one)
XOR	X axis data overrun. Default value: 0 (0: no overrun has occurred; 1: a new data for the X-axis has overwritten the previous one)
ZYXDA	X, Y and Z axis new data available. Default value: 0 (0: a new set of data is not yet available; 1: a new set of data is available)
ZDA	Z axis new data available. Default value: 0 (0: a new data for the Z-axis is not yet available; 1: a new data for the Z-axis is available)
YDA	Y axis new data available. Default value: 0 (0: a new data for the Y-axis is not yet available; 1: a new data for the Y-axis is available)
XDA	X axis new data available. Default value: 0 (0: a new data for the X-axis is not yet available; 1: a new data for the X-axis is available)

### 7.10 OUT\_X (29)

X-axis acceleration data. The value is expressed as two's complement with 6 bit data representation right justified.

### 7.11 OUT\_Y (2Bh)

Y-axis acceleration data. The value is expressed as two's complement with 6 bit data representation right justified.

### 7.12 OUT\_Z (2Dh)

Z-axis acceleration data. The value is expressed as two's complement with 6 bit data representation right justified.

## 7.13 INT1\_CFG (30h)

**Table 36. INT1\_CFG register**

AOI	6D	ZHIE	ZLIE	YHIE	YLIE	XHIE	XLIE
-----	----	------	------	------	------	------	------

**Table 37. INT1\_CFG description**

AOI	AND/OR combination of Interrupt events. Default value: 0. (See <a href="#">Table 38</a> )
6D	6 direction detection function enable. Default value: 0. (See <a href="#">Table 38</a> )
ZHIE	Enable interrupt generation on Z high event. Default value: 0 (0: disable interrupt request; 1: enable interrupt request on measured accel. value higher than preset threshold)
ZLIE	Enable interrupt generation on Z low event. Default value: 0 (0: disable interrupt request; 1: enable interrupt request on measured accel. value lower than preset threshold)
YHIE	Enable interrupt generation on Y high event. Default value: 0 (0: disable interrupt request; 1: enable interrupt request on measured accel. value higher than preset threshold)
YLIE	Enable interrupt generation on Y low event. Default value: 0 (0: disable interrupt request; 1: enable interrupt request on measured accel. value lower than preset threshold)
XHIE	Enable interrupt generation on X high event. Default value: 0 (0: disable interrupt request; 1: enable interrupt request on measured accel. value higher than preset threshold)
XLIE	Enable interrupt generation on X low event. Default value: 0 (0: disable interrupt request; 1: enable interrupt request on measured accel. value lower than preset threshold)

Configuration register for Interrupt 1 source.

**Table 38. Interrupt 1 source configurations**

AOI	6D	Interrupt mode
0	0	OR combination of interrupt events
0	1	6 direction movement recognition
1	0	AND combination of interrupt events
1	1	6 direction position recognition

## 7.14 INT1\_SRC (31h)

**Table 39. INT1\_SRC register**

0	IA	ZH	ZL	YH	YL	XH	XL
---	----	----	----	----	----	----	----

**Table 40. INT1\_SRC description**

IA	Interrupt active. Default value: 0 (0: no interrupt has been generated; 1: one or more interrupts have been generated)
ZH	Z high. Default value: 0 (0: no interrupt, 1: Z high event has occurred)
ZL	Z low. Default value: 0 (0: no interrupt; 1: Z low event has occurred)
YH	Y high. Default value: 0 (0: no interrupt, 1: Y high event has occurred)
YL	Y low. Default value: 0 (0: no interrupt, 1: Y low event has occurred)
XH	X high. Default value: 0 (0: no interrupt, 1: X high event has occurred)
XL	X low. Default value: 0 (0: no interrupt, 1: X low event has occurred)

Interrupt 1 source register. Read only register.

Reading at this address clears INT1\_SRC IA bit (and the interrupt signal on INT 1 pin) and allows the refreshment of data in the INT1\_SRC register if the latched option was chosen.

## 7.15 INT1\_THS (32h)

**Table 41. INT1\_THS register**

0	THS6	THS5	THS4	THS3	THS2	THS1	THS0
---	------	------	------	------	------	------	------

**Table 42. INT1\_THS description**

THS6 - THS0	Interrupt 1 threshold. Default value: 000 0000
-------------	--

## 7.16 INT1\_DURATION (33h)

**Table 43. INT1\_DURATION register**

0	D6	D5	D4	D3	D2	D1	D0
---	----	----	----	----	----	----	----

**Table 44. INT2\_DURATION description**

D6 - D0	Duration value. Default value: 000 0000
---------	---

**D6 - D0** bits set the minimum duration of the Interrupt 2 event to be recognized. Duration steps and maximum values depend on the ODR chosen.

## 7.17 INT2\_CFG (34h)

**Table 45. INT2\_CFG register**

AOI	6D	ZHIE	ZLIE	YHIE	YLIE	XHIE	XLIE
-----	----	------	------	------	------	------	------

**Table 46. INT2\_CFG description**

AOI	AND/OR combination of Interrupt events. Default value: 0. (See table below)
6D	6 direction detection function enable. Default value: 0. (See table below)
ZHIE	Enable interrupt generation on Z high event. Default value: 0 (0: disable interrupt request; 1: enable interrupt request on measured accel. value higher than preset threshold)
ZLIE	Enable interrupt generation on Z low event. Default value: 0 (0: disable interrupt request; 1: enable interrupt request on measured accel. value lower than preset threshold)
YHIE	Enable interrupt generation on Y high event. Default value: 0 (0: disable interrupt request; 1: enable interrupt request on measured accel. value higher than preset threshold)
YLIE	Enable interrupt generation on Y low event. Default value: 0 (0: disable interrupt request; 1: enable interrupt request on measured accel. value lower than preset threshold)
XHIE	Enable interrupt generation on X high event. Default value: 0 (0: disable interrupt request; 1: enable interrupt request on measured accel. value higher than preset threshold)
XLIE	Enable interrupt generation on X low event. Default value: 0 (0: disable interrupt request; 1: enable interrupt request on measured accel. value lower than preset threshold)

Configuration register for Interrupt 2 source.

**Table 47. Interrupt mode configuration**

AOI	6D	Interrupt mode
0	0	OR combination of interrupt events
0	1	6 direction movement recognition

**Table 47. Interrupt mode configuration (continued)**

AOI	6D	Interrupt mode
1	0	AND combination of interrupt events
1	1	6 direction position recognition

## 7.18 INT2\_SRC (35h)

**Table 48. INT2\_SRC register**

0	IA	ZH	ZL	YH	YL	XH	XL
---	----	----	----	----	----	----	----

**Table 49. INT2\_SRC description**

IA	Interrupt active. Default value: 0 (0: no interrupt has been generated; 1: one or more interrupts have been generated)
ZH	Z high. Default value: 0 (0: no interrupt, 1: Z high event has occurred)
ZL	Z low. Default value: 0 (0: no interrupt; 1: Z low event has occurred)
YH	Y high. Default value: 0 (0: no interrupt, 1: Y high event has occurred)
YL	Y low. Default value: 0 (0: no interrupt, 1: Y low event has occurred)
XH	X high. Default value: 0 (0: no interrupt, 1: X high event has occurred)
XL	X low. Default value: 0 (0: no interrupt, 1: X low event has occurred)

Interrupt 2 source register. Read only register.

Reading at this address clears INT2\_SRC IA bit (and the interrupt signal on INT 2 pin) and allows the refreshment of data in the INT2\_SRC register if the latched option was chosen.

## 7.19 INT2\_THS (36h)

**Table 50. INT2\_THS register**

0	THS6	THS5	THS4	THS3	THS2	THS1	THS0
---	------	------	------	------	------	------	------

**Table 51. INT2\_THS description**

THS6 - THS0	Interrupt 1 threshold. Default value: 000 0000
-------------	--

## 7.20 INT2\_DURATION (37h)

Table 52. INT2\_DURATION register

0	D6	D5	D4	D3	D2	D1	D0
---	----	----	----	----	----	----	----

Table 53. INT2\_DURATION description

D6 - D0	Duration value. Default value: 000 0000
---------	---

**D6 - D0** bits set the minimum duration of the Interrupt 2 event to be recognized. Duration time steps and maximum values depend on the ODR chosen.

# 8 Package information

In order to meet environmental requirements, ST offers these devices in different grades of ECOPACK® packages, depending on their level of environmental compliance. ECOPACK® specifications, grade definitions and product status are available at: [www.st.com](http://www.st.com). ECOPACK is an ST trademark.

**Figure 12. LGA16: mechanical data and package dimensions**

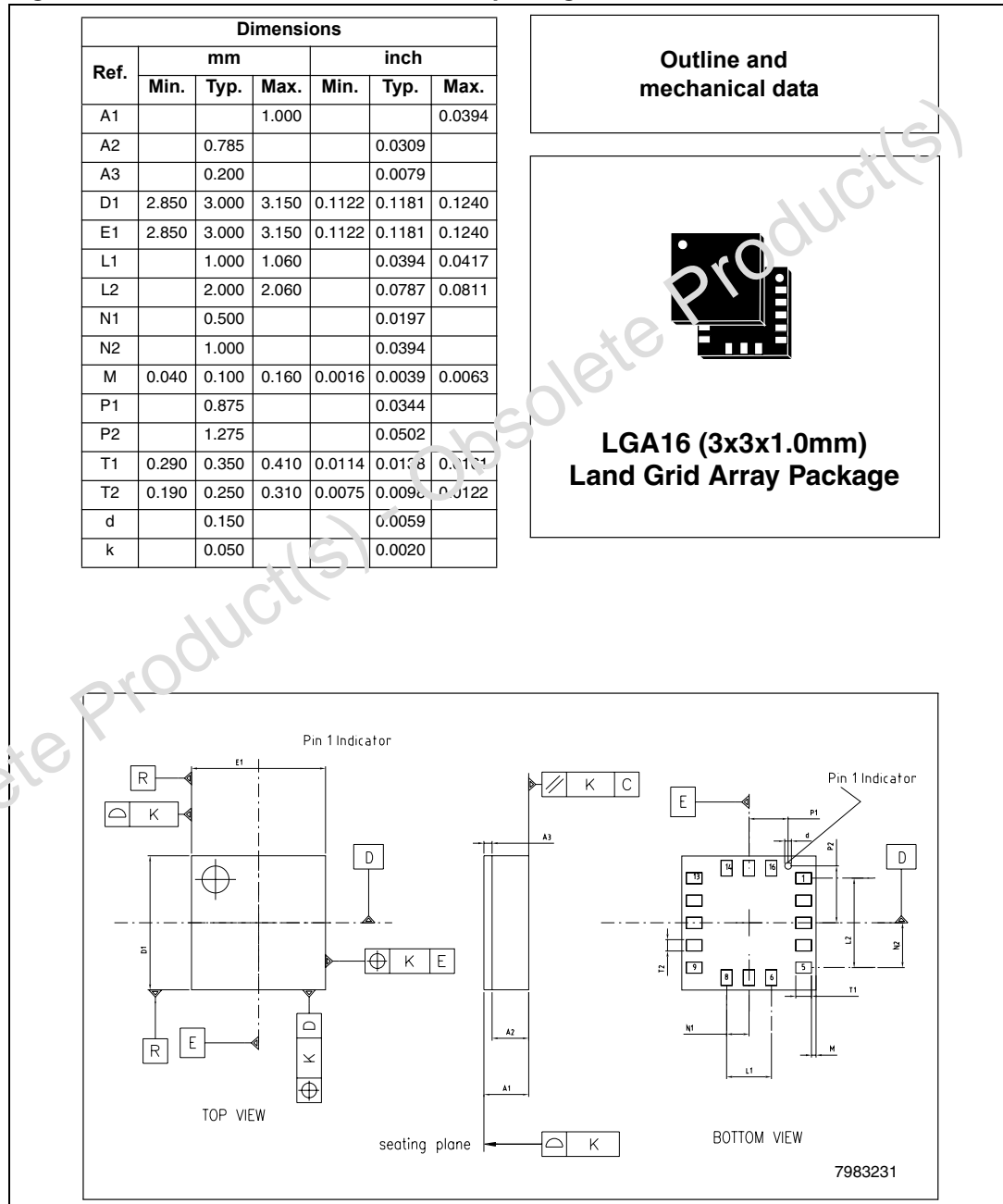

## 9 Revision history

**Table 54. Document revision history**

Date	Revision	Changes
16-Oct-2008	1	Initial release
03-Nov-2008	2	<a href="#">Table 10</a> , <a href="#">15</a> , <a href="#">16</a> have been updated
21-Nov-2008	3	Updated <a href="#">Table 4 on page 10</a>
10-Jul-2009	4	Updated: <a href="#">Table 3 on page 9</a> , <a href="#">Table 4 on page 10</a> , <a href="#">Table 6 on page 12</a> , <a href="#">Table 7 on page 13</a> , <a href="#">Table 28 on page 28</a> , <a href="#">Table 29 on page 29</a> Minor text changes to improve readability

**Please Read Carefully:**

Information in this document is provided solely in connection with ST products. STMicroelectronics NV and its subsidiaries ("ST") reserve the right to make changes, corrections, modifications or improvements, to this document, and the products and services described herein at any time, without notice.

All ST products are sold pursuant to ST's terms and conditions of sale.

Purchasers are solely responsible for the choice, selection and use of the ST products and services described herein, and ST assumes no liability whatsoever relating to the choice, selection or use of the ST products and services described herein.

No license, express or implied, by estoppel or otherwise, to any intellectual property rights is granted under this document. If any part of this document refers to any third party products or services it shall not be deemed a license grant by ST for the use of such third party products or services, or any intellectual property contained therein or considered as a warranty covering the use in any manner whatsoever of such third party products or services or any intellectual property contained therein.

**UNLESS OTHERWISE SET FORTH IN ST'S TERMS AND CONDITIONS OF SALE ST DISCLAIMS ANY EXPRESS OR IMPLIED WARRANTY WITH RESPECT TO THE USE AND/OR SALE OF ST PRODUCTS INCLUDING WITHOUT LIMITATION IMPLIED WARRANTIES OF MERCHANTABILITY, FITNESS FOR A PARTICULAR PURPOSE (AND THEIR EQUIVALENTS UNDER THE LAWS OF ANY JURISDICTION), OR INFRINGEMENT OF ANY PATENT, COPYRIGHT OR OTHER INTELLECTUAL PROPERTY RIGHT.**

**UNLESS EXPRESSLY APPROVED IN WRITING BY AN AUTHORIZED ST REPRESENTATIVE, ST PRODUCTS ARE NOT RECOMMENDED, AUTHORIZED OR WARRANTED FOR USE IN MILITARY, AIR CRAFT, SPACE, LIFE SAVING, OR LIFE SUSTAINING APPLICATIONS, NOR IN PRODUCTS OR SYSTEMS WHERE FAILURE OR MALFUNCTION MAY RESULT IN PERSONAL INJURY, DEATH, OR SEVERE PROPERTY OR ENVIRONMENTAL DAMAGE. ST PRODUCTS WHICH ARE NOT SPECIFIED AS "AUTOMOTIVE GRADE" MAY ONLY BE USED IN AUTOMOTIVE APPLICATIONS AT USER'S OWN RISK.**

Resale of ST products with provisions different from the statements and/or technical features set forth in this document shall immediately void any warranty granted by ST for the ST product or service described herein and shall not create or extend in any manner whatsoever, any liability of ST.

ST and the ST logo are trademarks or registered trademarks of ST in various countries.

Information in this document supersedes and replaces all information previously supplied.

The ST logo is a registered trademark of STMicroelectronics. All other names are the property of their respective owners.

© 2009 STMicroelectronics - All rights reserved

STMicroelectronics group of companies

Australia - Belgium - Brazil - Canada - China - Czech Republic - Finland - France - Germany - Hong Kong - India - Israel - Italy - Japan - Malaysia - Malta - Morocco - Philippines - Singapore - Spain - Sweden - Switzerland - United Kingdom - United States of America

[www.st.com](http://www.st.com)

## Looking for pricing, stock, or lifecycle information?

Click below to explore more details on WIN SOURCE:

- ⊖ [View LIS331DLFTR on WIN SOURCE](#)
- ⊖ [STMicroelectronics Information](#)

## Optimize Your Supply Chain with WIN SOURCE Solutions

- ✓ Global Sourcing Solution
- ✓ Obsolete Management
- ✓ Cost Control Management
- ✓ Shortage Management
- ✓ Alternative Solution
- ✓ Excess Inventory Management