



THE DATASHEET OF LM13700MX/NOPB



LM13700 Dual Operational Transconductance Amplifiers With Linearizing Diodes and Buffers

1 Features

- g_m Adjustable Over 6 Decades
- Excellent g_m Linearity
- Excellent Matching Between Amplifiers
- Linearizing Diodes for reduced output distortion
- High Impedance Buffers
- High Output Signal-to-Noise Ratio

2 Applications

- Current-Controlled Amplifiers
- Stereo Audio Amplifiers
- Current-Controlled Impedances
- Current-Controlled Filters
- Current-Controlled Oscillators
- Multiplexers
- Timers
- Sample-and-Hold Circuits

3 Description

The LM13700 series consists of two current-controlled transconductance amplifiers, each with differential inputs and a push-pull output. The two amplifiers share common supplies but otherwise operate independently. Linearizing diodes are provided at the inputs to reduce distortion and allow higher input levels. The result is a 10-dB signal-to-noise improvement referenced to 0.5 percent THD. High impedance buffers are provided which are especially designed to complement the dynamic range of the amplifiers. The output buffers of the LM13700 differ from those of the LM13600 in that their input bias currents (and thus their output DC levels) are independent of I_{ABC} . This may result in performance superior to that of the LM13600 in audio applications.

Device Information⁽¹⁾

PART NUMBER	PACKAGE	BODY SIZE (NOM)
LM13700	SOIC (16)	3.91 mm × 9.90 mm
	PDIP (16)	6.35 mm × 19.304 mm

(1) For all available packages, see the orderable addendum at the end of the data sheet.

Connection Diagram

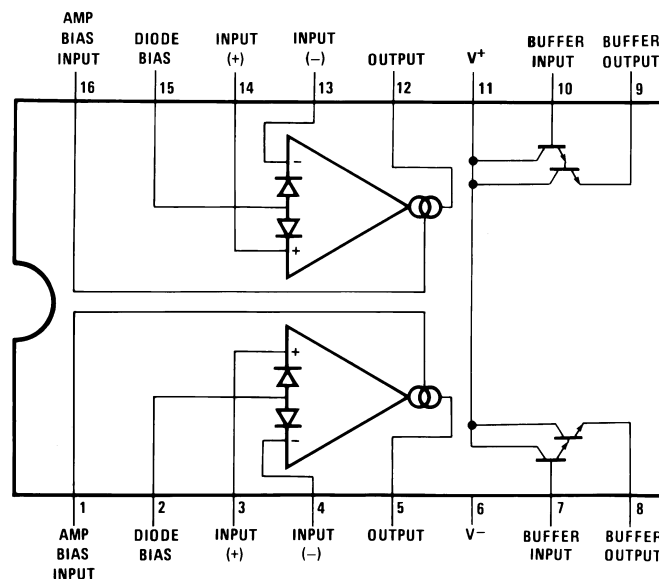

Table of Contents

1 Features 1 2 Applications 1 3 Description 1 4 Revision History 2 5 Pin Configuration and Functions 3 6 Specifications 4 6.1 Absolute Maximum Ratings 4 6.2 Recommended Operating Conditions 4 6.3 Thermal Information 4 6.4 Electrical Characteristics 5 6.5 Typical Characteristics 6 7 Detailed Description 9 7.1 Overview 9 7.2 Functional Block Diagram 9 7.3 Feature Description 9	7.4 Device Functional Modes 10 8 Application and Implementation 11 8.1 Application Information 11 8.2 Typical Application 11 8.3 System Examples 12 9 Power Supply Recommendations 29 10 Layout 29 10.1 Layout Guidelines 29 10.2 Layout Example 29 11 Device and Documentation Support 30 11.1 Community Resources 30 11.2 Trademarks 30 11.3 Electrostatic Discharge Caution 30 11.4 Glossary 30 12 Mechanical, Packaging, and Orderable Information 30
--	--

4 Revision History

NOTE: Page numbers for previous revisions may differ from page numbers in the current version.

Changes from Revision E (March 2013) to Revision F	Page
• Added <i>ESD Ratings</i> table, <i>Feature Description</i> section, <i>Device Functional Modes</i> , <i>Application and Implementation</i> section, <i>Power Supply Recommendations</i> section, <i>Layout</i> section, <i>Device and Documentation Support</i> section, and <i>Mechanical, Packaging, and Orderable Information</i> section.	1
• Removed soldering information in <i>Absolute Maximum Ratings</i> table	4

Changes from Revision D (March 2013) to Revision E	Page
• Changed layout of National Data Sheet to TI format	27

5 Pin Configuration and Functions

**D or NFG Package
16-Pin SOIC or PDIP
Top View**

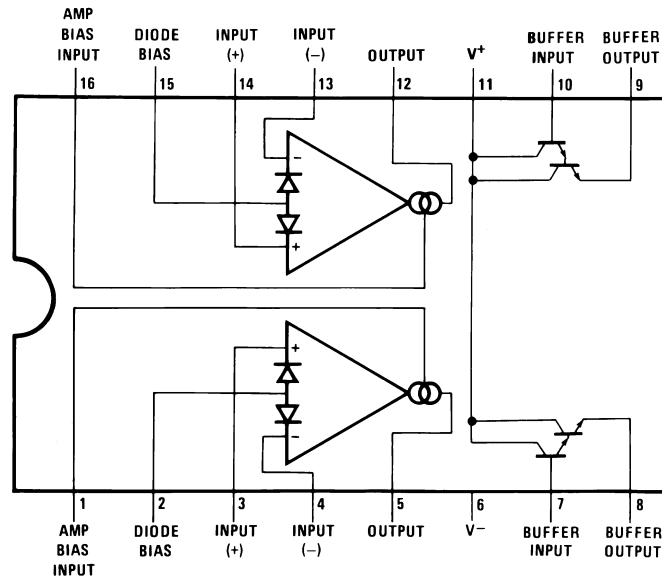

Pin Functions

PIN		I/O	DESCRIPTION
NAME	NO.		
Amp bias input	1, 16	A	Current bias input
Buffer input	7, 10	A	Buffer amplifier input
Buffer output	8, 9	A	Buffer amplifier output
Diode bias	2, 15	A	Linearizing diode bias input
Input+	3, 14	A	Positive input
Input-	4, 13	A	Negative input
Output	5, 12	A	Unbuffered output
V ⁺	11	P	Positive power supply
V ⁻	6	P	Negative power supply

6 Specifications

6.1 Absolute Maximum Ratings

over operating free-air temperature range (unless otherwise noted)⁽¹⁾

	MIN	MAX	UNIT
Supply voltage		36 V _{DC} or ±18	V
DC input voltage	+V _S	-V _S	V
Differential input voltage		±5	V
Diode bias current (I _D)		2	mA
Amplifier bias current (I _{ABC})		2	mA
Buffer output current ⁽²⁾		20	mA
Power dissipation ⁽³⁾ T _A = 25°C – LM13700N		570	mW
Output short circuit duration		Continuous	
Storage temperature, T _{stg}	-65	150	°C

- (1) Stresses beyond those listed under *Absolute Maximum Ratings* may cause permanent damage to the device. These are stress ratings only, which do not imply functional operation of the device at these or any other conditions beyond those indicated under *Recommended Operating Conditions*. Exposure to absolute-maximum-rated conditions for extended periods may affect device reliability.
- (2) Buffer output current should be limited so as to not exceed package dissipation.
- (3) For operation at ambient temperatures above 25°C, the device must be derated based on a 150°C maximum junction temperature and a thermal resistance, junction to ambient, as follows: LM13700N, 90°C/W; LM13700M, 110°C/W.

6.2 Recommended Operating Conditions

over operating free-air temperature range (unless otherwise noted)

		MIN	MAX	UNIT
V+ (single-supply configuration)		9.5	32	V
V+ (dual-supply configuration)		4.75	16	V
V- (dual-supply configuration)		-16	-4.75	V
Operating temperature, T _A	LM13700N	0	70	°C

6.3 Thermal Information

THERMAL METRIC ⁽¹⁾		LM13700		UNIT
		D (SOIC)	NFG (PDIP)	
		16 PINS	16 PINS	
R _{θJA}	Junction-to-ambient thermal resistance	83.0	43.8	°C/W
R _{θJC(top)}	Junction-to-case (top) thermal resistance	44.0	34.9	°C/W
R _{θJB}	Junction-to-board thermal resistance	40.5	28.3	°C/W
Ψ _{JT}	Junction-to-top characterization parameter	11.5	19.1	°C/W
Ψ _{JB}	Junction-to-board characterization parameter	40.2	28.2	°C/W

- (1) For more information about traditional and new thermal metrics, see the *Semiconductor and IC Package Thermal Metrics* application report, [SPRA953](#).

6.4 Electrical Characteristics

These specifications apply for $V_S = \pm 15\text{ V}$, $T_A = 25^\circ\text{C}$, amplifier bias current (I_{ABC}) = 500 μA , pins 2 and 15 open unless otherwise specified. The inputs to the buffers are grounded and outputs are open.

PARAMETER	TEST CONDITIONS	MIN	TYP	MAX	UNIT
Input offset voltage (V_{OS})	Over specified temperature range		0.4	4	mV
	$I_{ABC} = 5\ \mu\text{A}$		0.3	4	
V_{OS} including diodes	Diode bias current (I_D) = 500 μA		0.5	5	mV
Input offset change	$5\ \mu\text{A} \leq I_{ABC} \leq 500\ \mu\text{A}$		0.1	3	mV
Input offset current			0.1	0.6	μA
Input bias current			0.4	5	μA
	Over specified temperature range		1	8	
Forward transconductance (g_m)		6700	9600	13000	μS
	Over specified temperature range	5400			
g_m tracking			0.3		dB
Peak output current	$R_L = 0$, $I_{ABC} = 5\ \mu\text{A}$		5		μA
	$R_L = 0$, $I_{ABC} = 500\ \mu\text{A}$	350	500	650	
	$R_L = 0$, Over Specified Temp Range	300			
Supply current	$I_{ABC} = 500\ \mu\text{A}$, both channels		2.6		mA
CMRR		80	110		dB
Common-mode range		± 12	± 13.5		V
Crosstalk	Referred to input ⁽¹⁾ 20 Hz < f < 20 kHz		100		dB
Differential input current	$I_{ABC} = 0$, input = $\pm 4\text{ V}$		0.02	100	nA
Leakage current	$I_{ABC} = 0$ (refer to test circuit)		0.2	100	nA
Input resistance		10	26		k Ω
Open-loop bandwidth			2		MHz
Slew rate	Unity gain compensated		50		V/ μs
Buffer input current	See ⁽¹⁾		0.5	2	μA
Peak buffer output voltage	See ⁽¹⁾	10			V
PEAK OUTPUT VOLTAGE					
Positive	$R_L = \infty$, $5\ \mu\text{A} \leq I_{ABC} \leq 500\ \mu\text{A}$	12	14.2		V
Negative	$R_L = \infty$, $5\ \mu\text{A} \leq I_{ABC} \leq 500\ \mu\text{A}$	-12	-14.4		V
V_{OS} SENSITIVITY					
Positive	$\Delta V_{OS}/\Delta V^+$		20	150	$\mu\text{V}/\text{V}$
Negative	$\Delta V_{OS}/\Delta V^-$		20	150	$\mu\text{V}/\text{V}$

(1) These specifications apply for $V_S = \pm 15\text{ V}$, $I_{ABC} = 500\ \mu\text{A}$, $R_{OUT} = 5\text{-k}\Omega$ connected from the buffer output to $-V_S$ and the input of the buffer is connected to the transconductance amplifier output.

6.5 Typical Characteristics

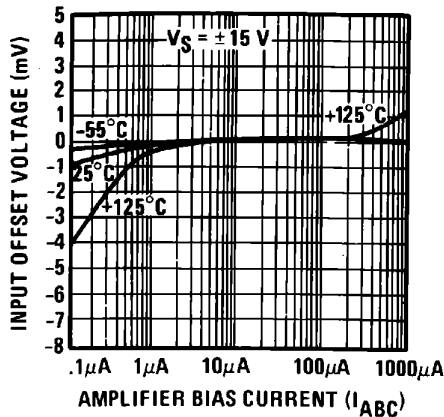

Figure 1. Input Offset Voltage

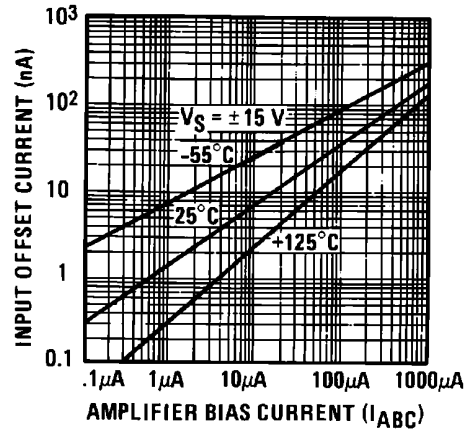

Figure 2. Input Offset Current

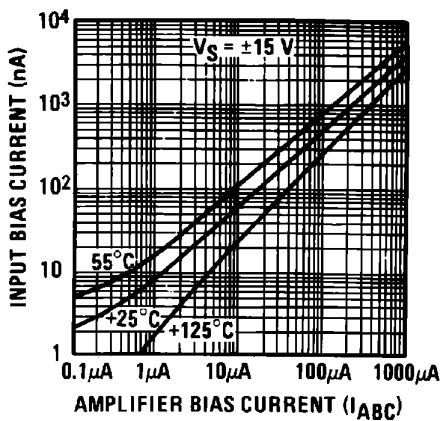

Figure 3. Input Bias Current

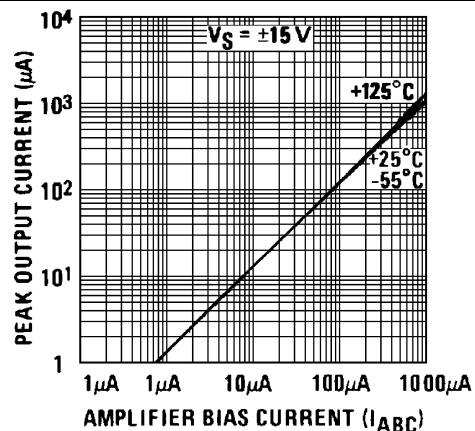

Figure 4. Peak Output Current

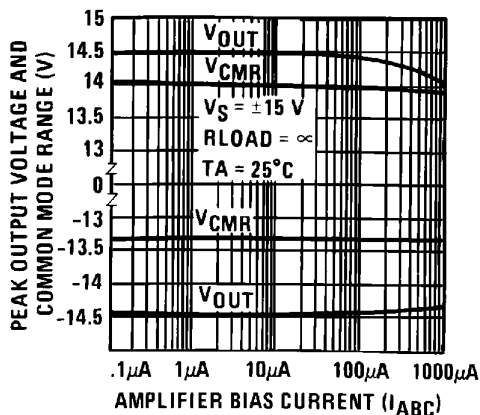

Figure 5. Peak Output Voltage and Common Mode Range

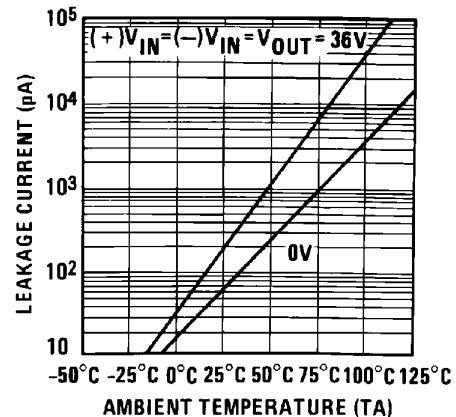

Figure 6. Leakage Current

Typical Characteristics (continued)

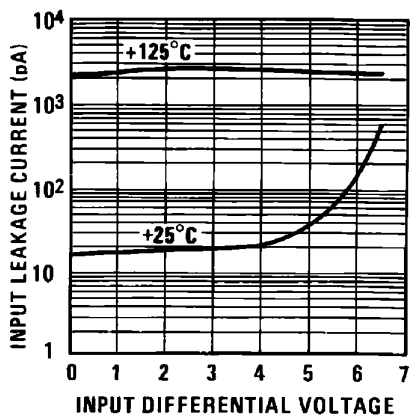

Figure 7. Input Leakage

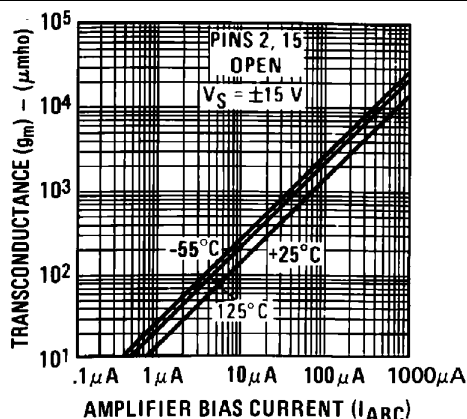

Figure 8. Transconductance

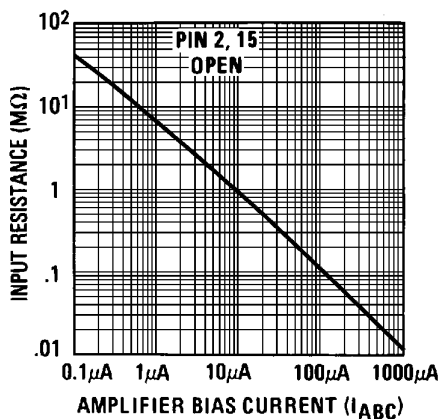

Figure 9. Input Resistance

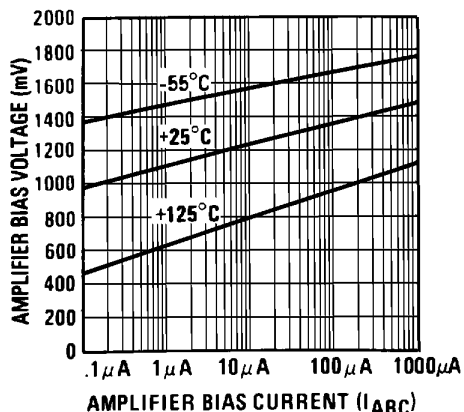

Figure 10. Amplifier Bias Voltage vs. Amplifier Bias Current

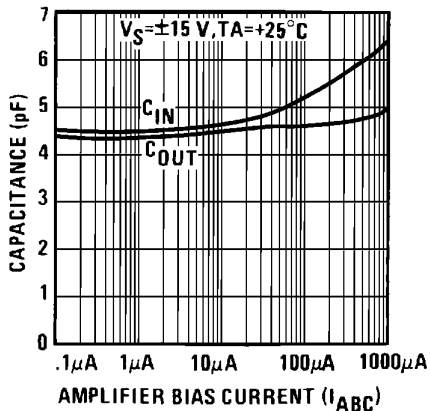

Figure 11. Input and Output Capacitance

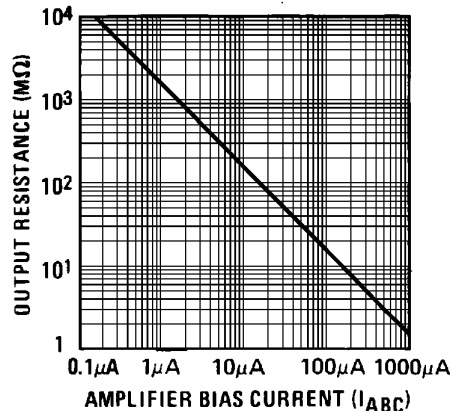

Figure 12. Output Resistance

Typical Characteristics (continued)

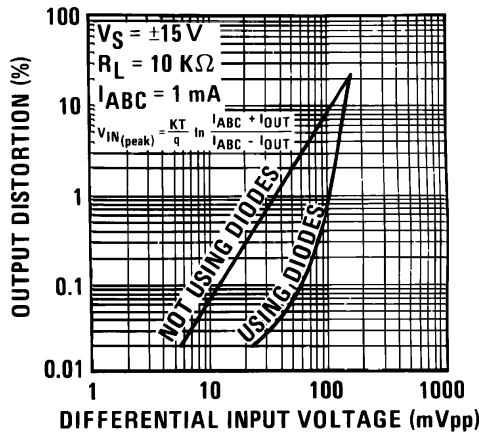

Figure 13. Distortion vs. Differential Input Voltage

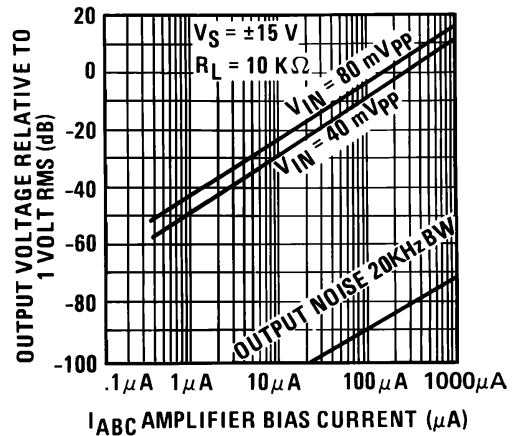

Figure 14. Voltage vs. Amplifier Bias Current

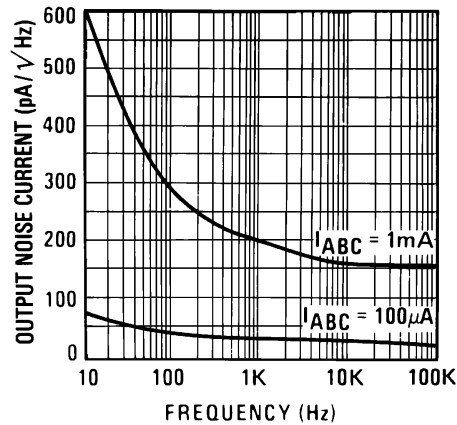

Figure 15. Output Noise vs Frequency

7 Detailed Description

7.1 Overview

The LM13700 is a two channel current controlled differential input transconductance amplifier with additional output buffers. The inputs include linearizing diodes to reduce distortion, and the output current is controlled by a dedicated pin. The outputs can sustain a continuous short to ground.

7.2 Functional Block Diagram

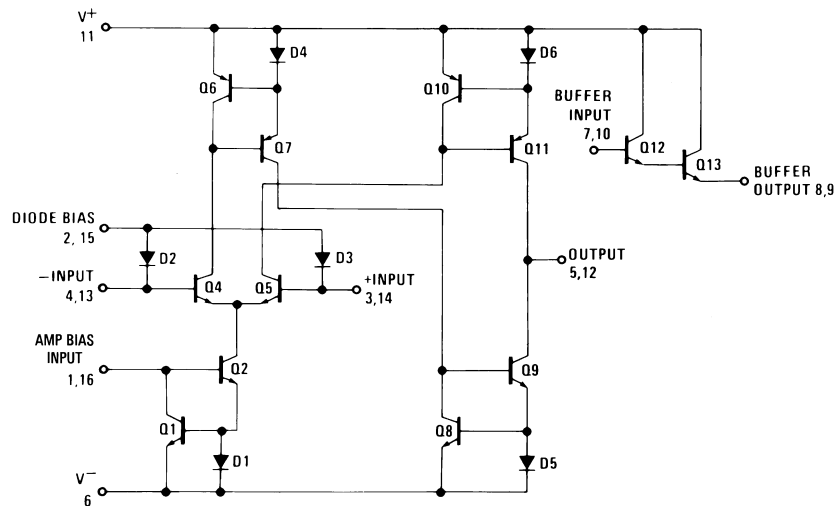

Figure 16. One Operational Transconductance Amplifier

7.3 Feature Description

7.3.1 Circuit Description

The differential transistor pair Q_4 and Q_5 form a transconductance stage in that the ratio of their collector currents is defined by the differential input voltage according to the transfer function:

$$V_{IN} = \frac{kT}{q} \ln \frac{I_5}{I_4} \quad (1)$$

where V_{IN} is the differential input voltage, kT/q is approximately 26 mV at 25°C and I_5 and I_4 are the collector currents of transistors Q_5 and Q_4 respectively. With the exception of Q_{12} and Q_{13} , all transistors and diodes are identical in size. Transistors Q_1 and Q_2 with Diode D_1 form a current mirror which forces the sum of currents I_4 and I_5 to equal I_{ABC} :

$$I_4 + I_5 = I_{ABC} \quad (2)$$

where I_{ABC} is the amplifier bias current applied to the gain pin.

For small differential input voltages the ratio of I_4 and I_5 approaches unity and the Taylor series of the \ln function is approximated as:

$$\frac{kT}{q} \ln \frac{I_5}{I_4} \approx \frac{kT}{q} \frac{I_5 - I_4}{I_4} \quad (3)$$

$$I_4 \approx I_5 \approx \frac{I_{ABC}}{2}$$

$$V_{IN} \left[\frac{I_{ABC}^2}{2kT} \right] = I_5 - I_4 \quad (4)$$

Feature Description (continued)

Collector currents I_4 and I_5 are not very useful by themselves and it is necessary to subtract one current from the other. The remaining transistors and diodes form three current mirrors that produce an output current equal to I_5 minus I_4 thus:

$$V_{IN} \left[\frac{I_{ABC}^q}{2kT} \right] = I_{OUT} \quad (5)$$

The term in brackets is then the transconductance of the amplifier and is proportional to I_{ABC} .

7.3.2 Linearizing Diodes

For differential voltages greater than a few millivolts, Equation 3 becomes less valid and the transconductance becomes increasingly nonlinear. Figure 19 demonstrates how the internal diodes can linearize the transfer function of the amplifier. For convenience assume the diodes are biased with current sources and the input signal is in the form of current I_S . Since the sum of I_4 and I_5 is I_{ABC} and the difference is I_{OUT} , currents I_4 and I_5 is written as follows:

$$I_4 = \frac{I_{ABC}}{2} - \frac{I_{OUT}}{2}, \quad I_5 = \frac{I_{ABC}}{2} + \frac{I_{OUT}}{2} \quad (6)$$

Since the diodes and the input transistors have identical geometries and are subject to similar voltages and temperatures, the following is true:

$$\frac{kT}{q} \ln \frac{\frac{I_D}{2} + I_S}{\frac{I_D}{2} - I_S} = \frac{kT}{q} \ln \frac{\frac{I_{ABC}}{2} + \frac{I_{OUT}}{2}}{\frac{I_{ABC}}{2} - \frac{I_{OUT}}{2}}$$

$$\therefore I_{OUT} = I_S \left(\frac{2I_{ABC}}{I_D} \right) \text{ for } |I_S| < \frac{I_D}{2} \quad (7)$$

Notice that in deriving Equation 7 no approximations have been made and there are no temperature-dependent terms. The limitations are that the signal current not exceed $I_D / 2$ and that the diodes be biased with currents. In practice, replacing the current sources with resistors will generate insignificant errors.

7.4 Device Functional Modes

Use in single ended or dual supply systems requires minimal changes. The outputs can support a sustained short to ground. Note that use of the LM13700 in ± 5 V supply systems requires will reduce signal dynamic range; this is due to the PNP transistors having a higher V_{BE} than the NPN transistors.

7.4.1 Output Buffers

Each channel includes a separate output buffer which consists of a Darlington pair transistor that can drive up to 20mA.

8 Application and Implementation

NOTE

Information in the following applications sections is not part of the TI component specification, and TI does not warrant its accuracy or completeness. TI's customers are responsible for determining suitability of components for their purposes. Customers should validate and test their design implementation to confirm system functionality.

8.1 Application Information

An OTA is a versatile building block analog component that can be considered an ideal transistor. The LM13700 can be used in a wide variety of applications, from voltage-controlled amplifiers and filters to VCOs. The 2 well-matched, independent channels make the LDC13700 well suited for stereo audio applications.

8.2 Typical Application

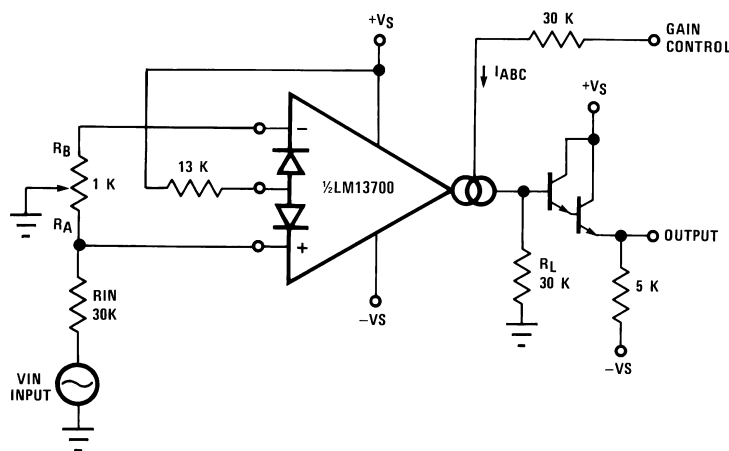

Figure 17. Voltage Controlled Amplifier

8.2.1 Design Requirements

For this example application, the system requirements provide a volume control for a 1 V_P input signal with a THD < 0.1% using ±15 V supplies. The volume control varies between -13 V and 15 V and needs to provide an adjustable gain range of >30dB.

8.2.2 Detailed Design Procedure

Using the linearizing diodes is recommended for most applications, as they greatly reduce the output distortion. It is required that the diode bias current, I_D be greater than twice the input current, I_S. As the input voltage has a DC level of 0 V, the Diode Bias input pins are 1 diode drop above 0 V, which is +0.7 V. Tying the bias to the clean V+ supply, results in a voltage drop of 14.3 V across R_D. Using the recommended 1mA for I_D is appropriate here, and with VS=+15 V, the voltage drop is 14.3 V, and so using the standard value of 13-kΩ is acceptable and will provide the desired gain control.

To obtain the <0.1% THD requirement, the differential input voltage must be <60mV_{pp} when the linearizing diodes are used. The input divider on the input will reduce the 1 V_P input to 33mV_{pp}, which is within the desired spec.

Next, set I_{BIAS}. The Bias Input pins (pins 1 or 16), are 2 diode drops above the negative supply, and therefore V_{BIAS} = 2(V_{BE}) + V₋, which for this application is -13.6 V. To set I_{BIAS} to 1ma when V_C = 15 V requires a 28.6-kΩ; 30-kΩ is a standard value and is used for this application. The gain will be linear with the applied voltage.

Typical Application (continued)

8.2.3 Application Curve

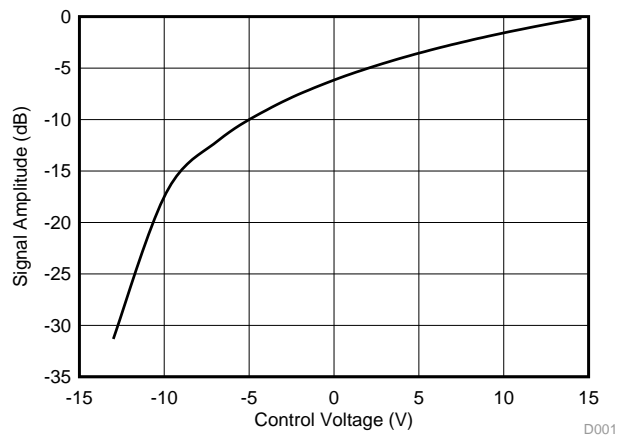

Figure 18. Signal Amplitude vs Control Voltage

8.3 System Examples

8.3.1 Voltage-Controlled Amplifiers

Figure 20 shows how the linearizing diodes is used in a voltage-controlled amplifier. To understand the input biasing, it is best to consider the 13-kΩ resistor as a current source and use a Thevenin equivalent circuit as shown in Figure 21. This circuit is similar to Figure 19 and operates the same. The potentiometer in Figure 20 is adjusted to minimize the effects of the control signal at the output.

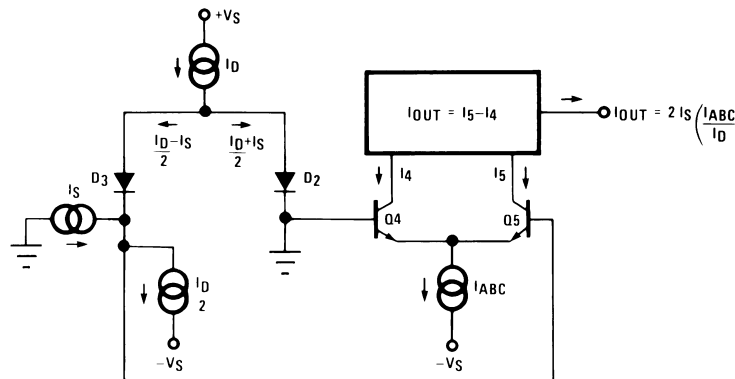

Figure 19. Linearizing Diodes

For optimum signal-to-noise performance, I_{ABC} should be as large as possible as shown by the Output Voltage vs Amplifier Bias Current graph. Larger amplitudes of input signal also improve the S/N ratio. The linearizing diodes help here by allowing larger input signals for the same output distortion as shown by the Distortion vs. Differential Input Voltage graph. S/N may be optimized by adjusting the magnitude of the input signal via R_{IN} (Figure 20) until the output distortion is below the desired level. The output voltage swing can then be set at any level by selecting R_L .

Although the noise contribution of the linearizing diodes is negligible relative to the contribution of the amplifier's internal transistors, I_D should be as large as possible. This minimizes the dynamic junction resistance of the diodes (r_e) and maximizes their linearizing action when balanced against R_{IN} . A value of 1 mA is recommended for I_D unless the specific application demands otherwise.

System Examples (continued)

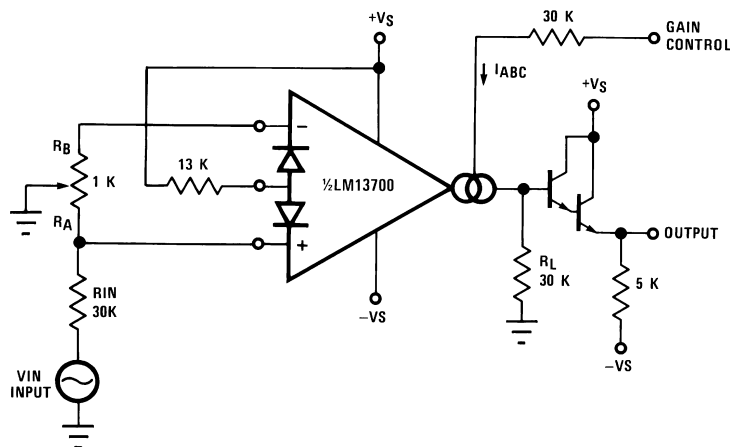

Figure 20. Voltage-Controlled Amplifier

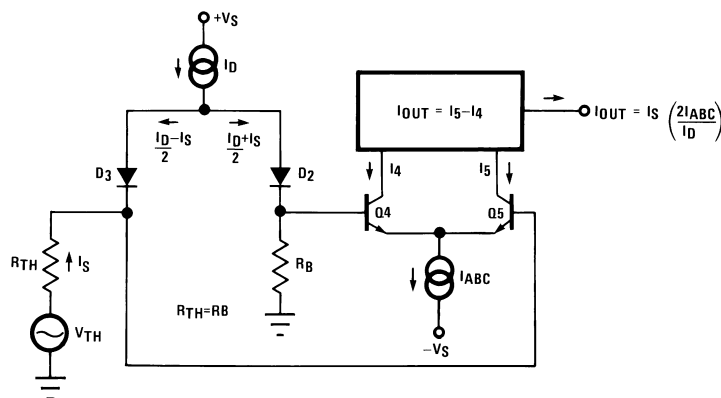

Figure 21. Equivalent VCA Input Circuit

8.3.2 Stereo Volume Control

The circuit of Figure 22 uses the excellent matching of the two LM13700 amplifiers to provide a Stereo Volume Control with a typical channel-to-channel gain tracking of 0.3 dB. R_P is provided to minimize the output offset voltage and may be replaced with two 510Ω resistors in AC-coupled applications. For the component values given, amplifier gain is derived for Figure 20 as being:

$$\frac{V_O}{V_{IN}} = 940 \times I_{ABC} \tag{8}$$

If V_C is derived from a second signal source then the circuit becomes an amplitude modulator or two-quadrant multiplier as shown in Figure 23, where:

$$I_O = \frac{-2I_S}{I_D} (I_{ABC}) = \frac{-2I_S}{I_D} \frac{V_{IN2}}{R_C} - \frac{2I_S}{I_D} \frac{(V^- + 1.4V)}{R_C} \tag{9}$$

The constant term in the above equation may be cancelled by feeding $I_S \times I_D R_C / 2(V^- + 1.4 V)$ into I_O . The circuit of Figure 24 adds R_M to provide this current, resulting in a four-quadrant multiplier where R_C is trimmed such that $V_O = 0 V$ for $V_{IN2} = 0 V$. R_M also serves as the load resistor for I_O .

System Examples (continued)

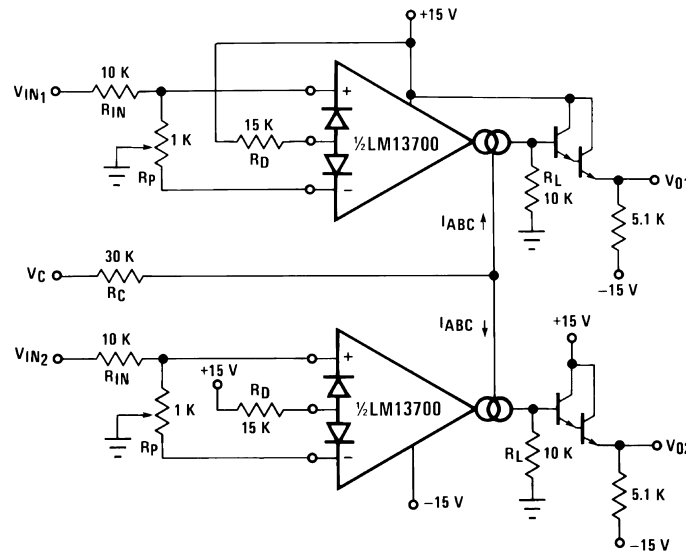

Figure 22. Stereo Volume Control

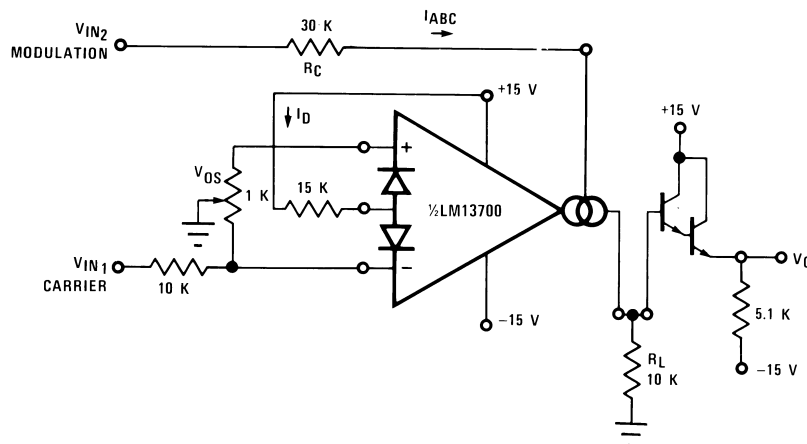

Figure 23. Amplitude Modulator

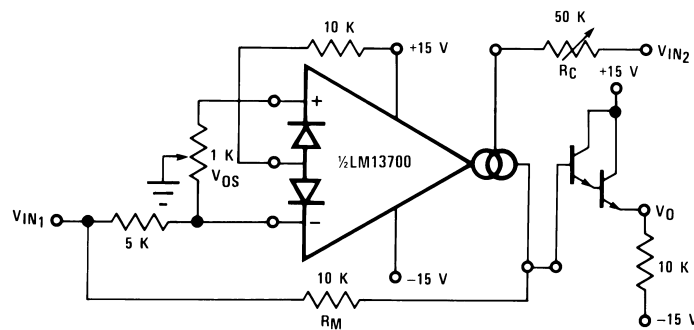

Figure 24. Four-Quadrant Multiplier

System Examples (continued)

Noting that the gain of the LM13700 amplifier of Figure 21 may be controlled by varying the linearizing diode current I_D as well as by varying I_{ABC} , Figure 25 shows an AGC Amplifier using this approach. As V_O reaches a high enough amplitude ($3 V_{BE}$) to turn on the Darlington transistors and the linearizing diodes, the increase in I_D reduces the amplifier gain so as to hold V_O at that level.

8.3.3 Voltage-Controlled Resistors

An Operational Transconductance Amplifier (OTA) may be used to implement a Voltage Controlled Resistor as shown in Figure 26. A signal voltage applied at R_X generates a V_{IN} to the LM13700 which is then multiplied by the g_m of the amplifier to produce an output current, thus:

$$R_X = \frac{R + R_A}{g_m R_A} \quad (10)$$

where $g_m \approx 19.2I_{ABC}$ at 25°C. Note that the attenuation of V_O by R and R_A is necessary to maintain V_{IN} within the linear range of the LM13700 input.

Figure 27 shows a similar VCR where the linearizing diodes are added, essentially improving the noise performance of the resistor. A floating VCR is shown in Figure 28, where each “end” of the “resistor” may be at any voltage within the output voltage range of the LM13700.

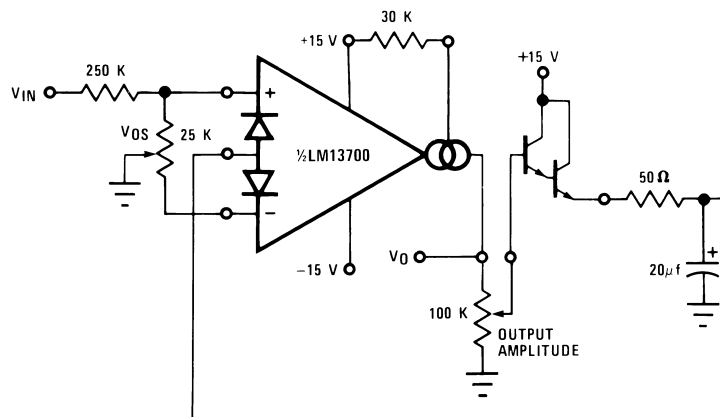

Figure 25. AGC Amplifier

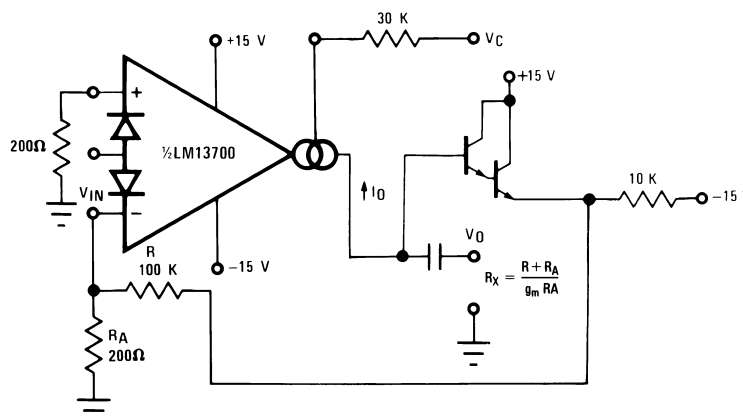
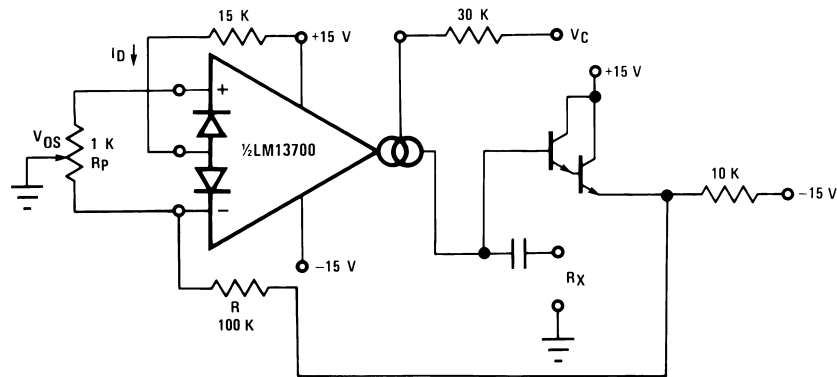
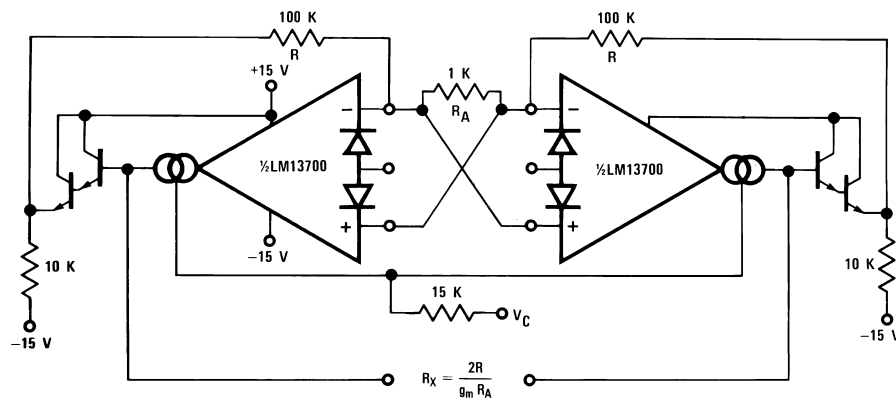

Figure 26. Voltage-Controlled Resistor, Single-Ended

System Examples (continued)

Figure 27. Voltage-Controlled Resistor with Linearizing Diodes
8.3.4 Voltage-Controlled Filters

OTA's are extremely useful for implementing voltage controlled filters, with the LM13700 having the advantage that the required buffers are included on the I.C. The VC Lo-Pass Filter of [Figure 29](#) performs as a unity-gain buffer amplifier at frequencies below cut-off, with the cut-off frequency being the point at which X_C/g_m equals the closed-loop gain of (R/R_A) . At frequencies above cut-off the circuit provides a single RC roll-off (6 dB per octave) of the input signal amplitude with a -3 dB point defined by the given equation, where g_m is again $19.2 \times I_{ABC}$ at room temperature. [Figure 30](#) shows a VC High-Pass Filter which operates in much the same manner, providing a single RC roll-off below the defined cut-off frequency.

Additional amplifiers may be used to implement higher order filters as demonstrated by the two-pole Butterworth Lo-Pass Filter of [Figure 31](#) and the state variable filter of [Figure 32](#). Due to the excellent g_m tracking of the two amplifiers, these filters perform well over several decades of frequency.

Figure 28. Floating Voltage-Controlled Resistor

System Examples (continued)

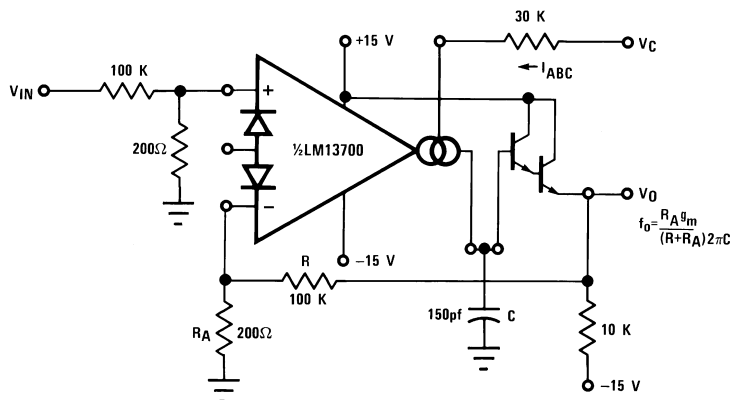
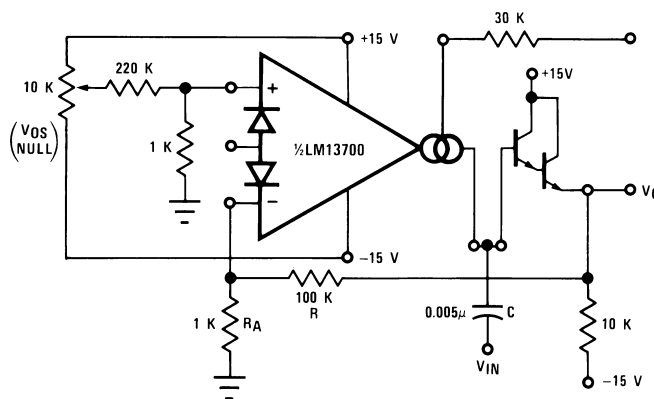

Figure 29. Voltage-Controlled Low-Pass Filter



$$f_0 = \frac{R_A g_m}{(R + R_A) 2\pi C}$$

Figure 30. Voltage-Controlled Hi-Pass Filter

System Examples (continued)

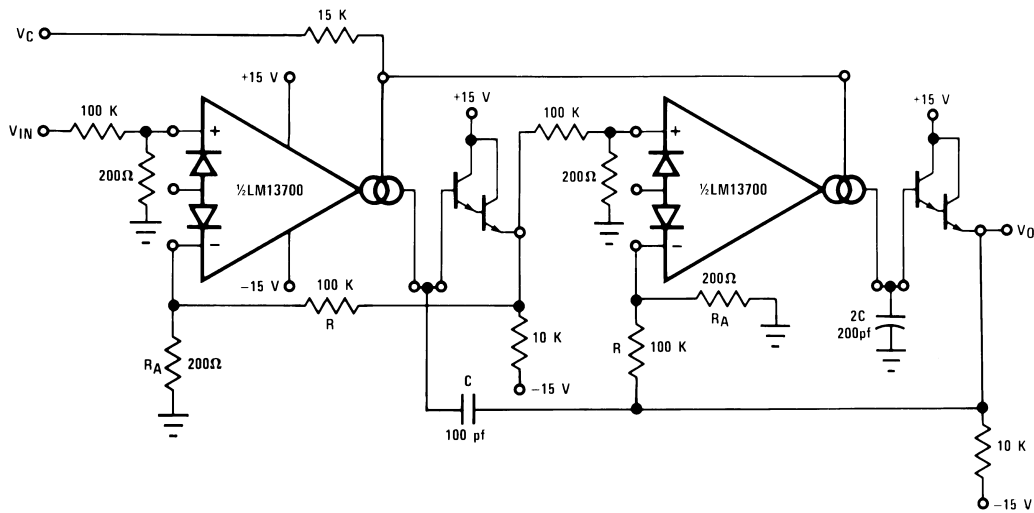

$$f_o = \frac{R_A g_m}{(R + R_A) 2\pi C}$$

Figure 31. Voltage-Controlled 2-Pole Butterworth Lo-Pass Filter

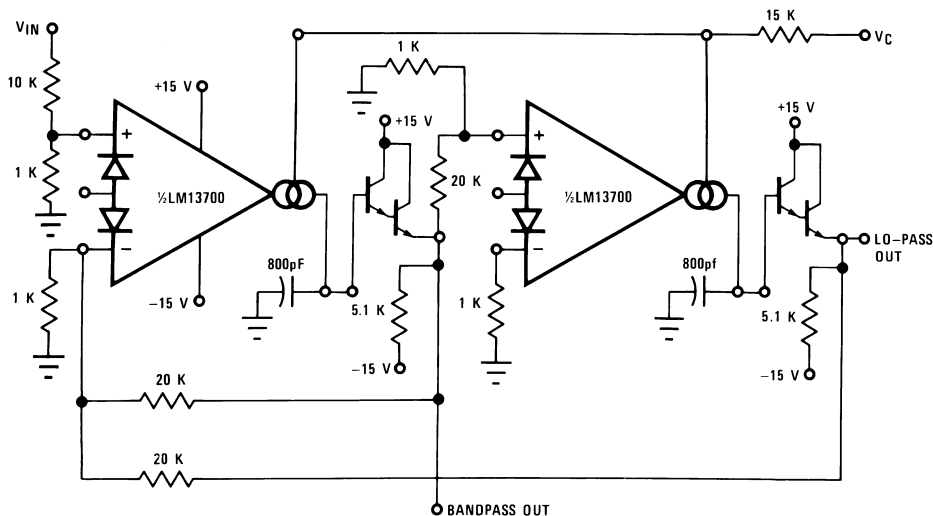

Figure 32. Voltage-Controlled State Variable Filter

8.3.5 Voltage-Controlled Oscillators

The classic Triangular/Square Wave VCO of Figure 33 is one of a variety of Voltage Controlled Oscillators which may be built utilizing the LM13700. With the component values shown, this oscillator provides signals from 200 kHz to below 2 Hz as I_C is varied from 1 mA to 10 nA. The output amplitudes are set by $I_A \times R_A$. Note that the peak differential input voltage must be less than 5 V to prevent zenering the inputs.

A few modifications to this circuit produce the ramp/pulse VCO of Figure 34. When V_{O2} is high, I_F is added to I_C to increase amplifier A1's bias current and thus to increase the charging rate of capacitor C. When V_{O2} is low, I_F goes to zero and the capacitor discharge current is set by I_C .

System Examples (continued)

The VC Lo-Pass Filter of Figure 29 may be used to produce a high-quality sinusoidal VCO. The circuit of Figure 34 employs two LM13700 packages, with three of the amplifiers configured as lo-pass filters and the fourth as a limiter/inverter. The circuit oscillates at the frequency at which the loop phase-shift is 360° or 180° for the inverter and 60° per filter stage. This VCO operates from 5 Hz to 50 kHz with less than 1% THD.

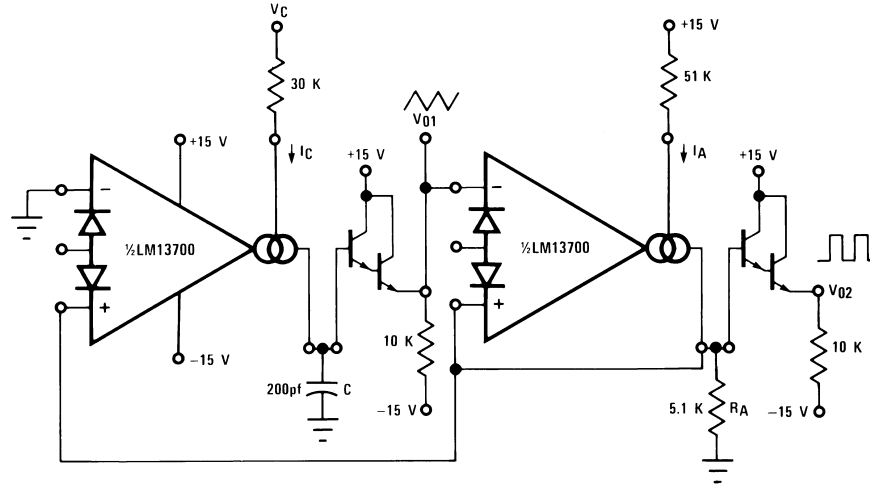

$$f_{osc} = \frac{I_C}{4C I_A R_A}$$

Figure 33. Triangular/Square-Wave VCO

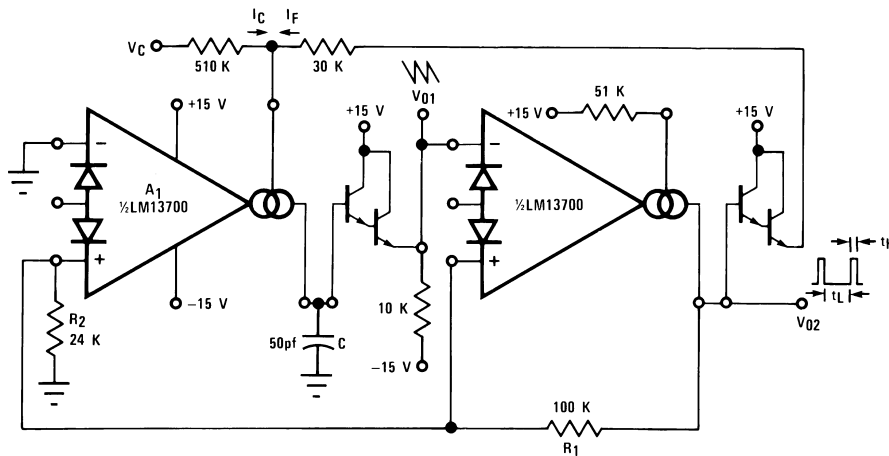

$$V_{PK} = \frac{(V^+ \pm 0.8V) R_2}{R_1 + R_2}$$

$$t_{H1} \approx \frac{2V_{PK}C}{I_F}$$

$$t_L = \frac{2V_{PK}C}{I_C}$$

$$f_0 \approx \frac{I_C}{2V_{PK}C} \text{ for } I_C \ll I_F$$

Figure 34. Ramp/Pulse VCO

System Examples (continued)

Figure 35. Sinusoidal VCO

Figure 36 shows how to build a VCO using one amplifier when the other amplifier is needed for another function.

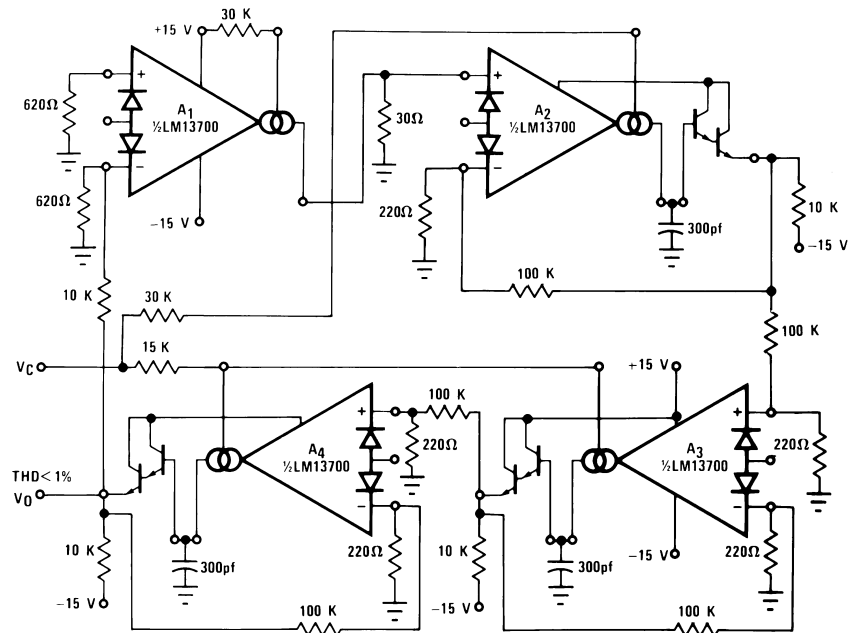
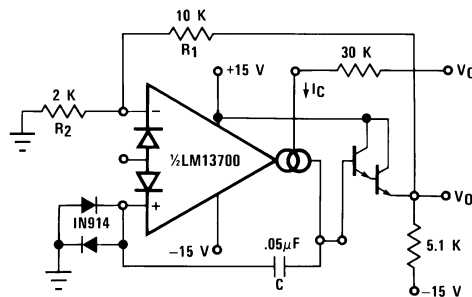

Figure 36. Single Amplifier VCO
8.3.6 Additional Applications

Figure 37 presents an interesting one-shot which draws no power supply current until it is triggered. A positive-going trigger pulse of at least 2 V amplitude turns on the amplifier through R_B and pulls the non-inverting input high. The amplifier regenerates and latches its output high until capacitor C charges to the voltage level on the non-inverting input. The output then switches low, turning off the amplifier and discharging the capacitor. The capacitor discharge rate is speeded up by shorting the diode bias pin to the inverting input so that an additional discharge current flows through D_1 when the amplifier output switches low. A special feature of this timer is that the other amplifier, when biased from V_O , can perform another function and draw zero stand-by power as well.

System Examples (continued)

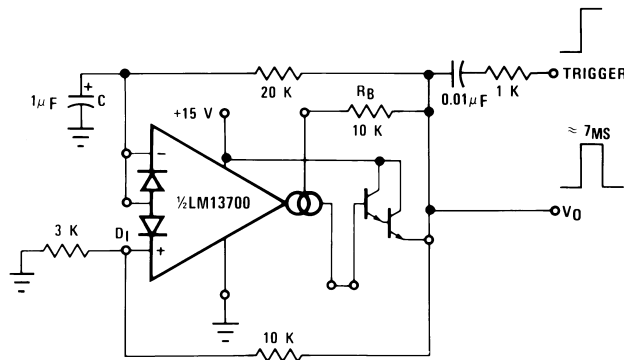

Figure 37. Zero Stand-By Power Timer

The operation of the multiplexer of Figure 38 is very straightforward. When A1 is turned on it holds V_O equal to V_{IN1} and when A2 is supplied with bias current then it controls V_O . C_C and R_C serve to stabilize the unity-gain configuration of amplifiers A1 and A2. The maximum clock rate is limited to about 200 kHz by the LM13700 slew rate into 150 pF when the $(V_{IN1}-V_{IN2})$ differential is at its maximum allowable value of 5 V.

The Phase-Locked Loop of Figure 39 uses the four-quadrant multiplier of Figure 24 and the VCO of Figure 36 to produce a PLL with a $\pm 5\%$ hold-in range and an input sensitivity of about 300 mV.

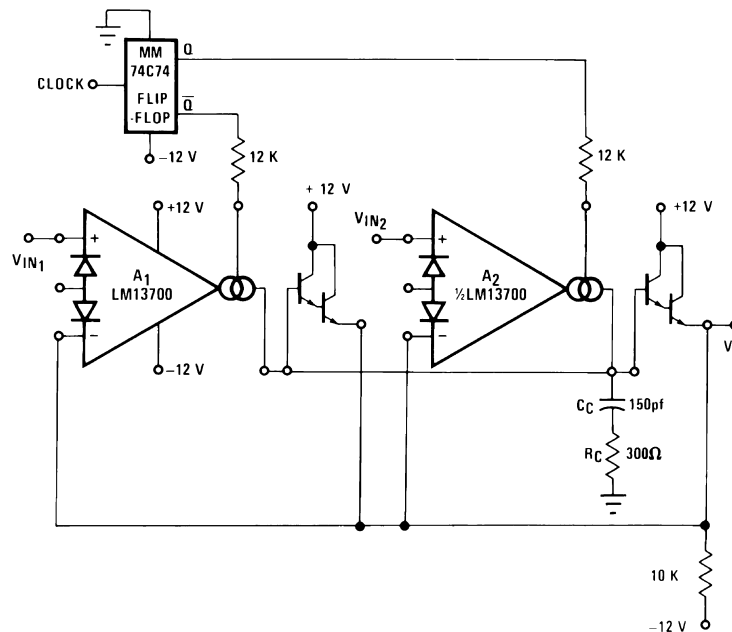
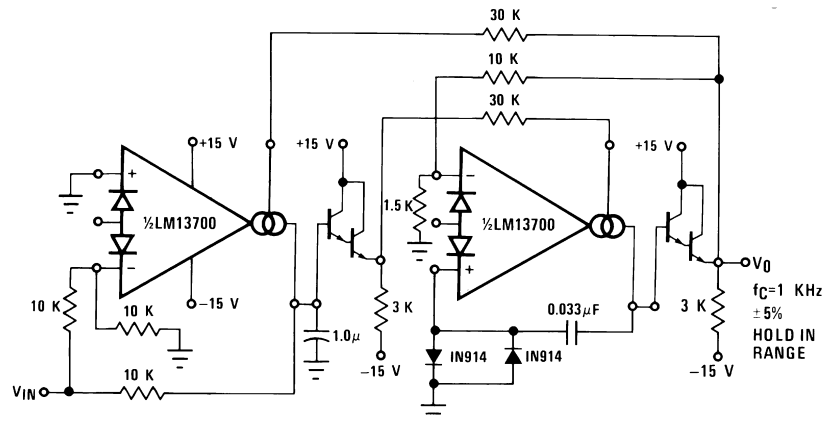
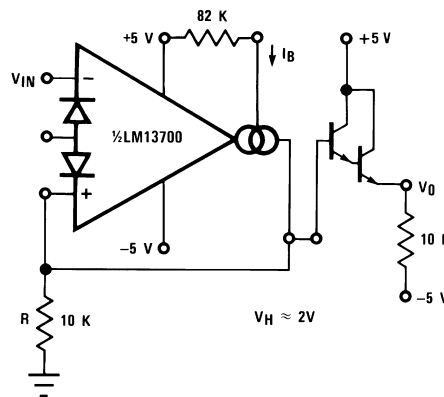

Figure 38. Multiplexer

System Examples (continued)

Figure 39. Phase Lock Loop

The Schmitt Trigger of [Figure 40](#) uses the amplifier output current into R to set the hysteresis of the comparator; thus $V_H = 2 \times R \times I_B$. Varying I_B will produce a Schmitt Trigger with variable hysteresis.

Figure 40. Schmitt Trigger

[Figure 41](#) shows a Tachometer or Frequency-to-Voltage converter. Whenever A1 is toggled by a positive-going input, an amount of charge equal to $(V_H - V_L) C_t$ is sourced into C_t and R_t . This once per cycle charge is then balanced by the current of V_O/R_t . The maximum F_{IN} is limited by the amount of time required to charge C_t from V_L to V_H with a current of I_B , where V_L and V_H represent the maximum low and maximum high output voltage swing of the LM13700. D1 is added to provide a discharge path for C_t when A1 switches low.

The Peak Detector of [Figure 42](#) uses A2 to turn on A1 whenever V_{IN} becomes more positive than V_O . A1 then charges storage capacitor C to hold V_O equal to V_{IN} PK. Pulling the output of A2 low through D1 serves to turn off A1 so that V_O remains constant.

System Examples (continued)

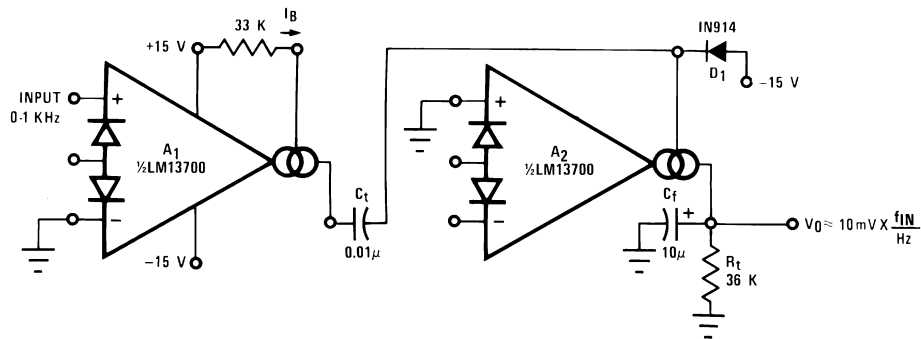

Figure 41. Tachometer

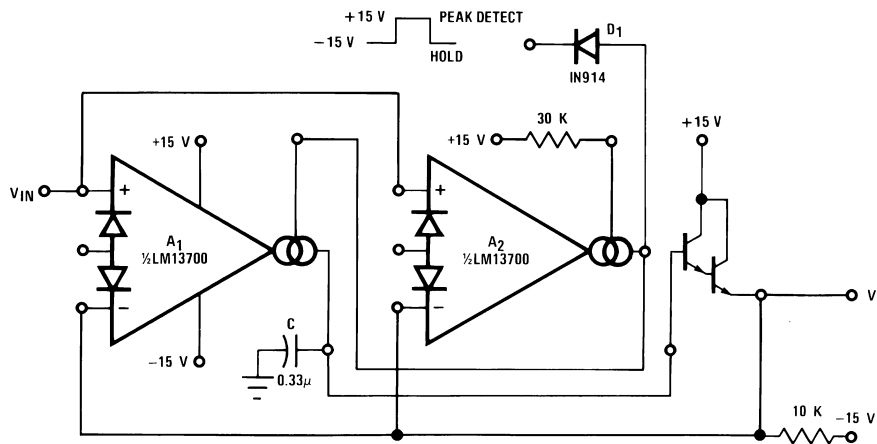

Figure 42. Peak Detector and Hold Circuit

The Ramp-and-Hold of [Figure 44](#) sources I_B into capacitor C whenever the input to A1 is brought high, giving a ramp-rate of about 1 V/ms for the component values shown.

The true-RMS converter of [Figure 45](#) is essentially an automatic gain control amplifier which adjusts its gain such that the AC power at the output of amplifier A1 is constant. The output power of amplifier A1 is monitored by squaring amplifier A2 and the average compared to a reference voltage with amplifier A3. The output of A3 provides bias current to the diodes of A1 to attenuate the input signal. Because the output power of A1 is held constant, the RMS value is constant and the attenuation is directly proportional to the RMS value of the input voltage. The attenuation is also proportional to the diode bias current. Amplifier A4 adjusts the ratio of currents through the diodes to be equal and therefore the voltage at the output of A4 is proportional to the RMS value of the input voltage. The calibration potentiometer is set such that V_O reads directly in RMS volts.

System Examples (continued)

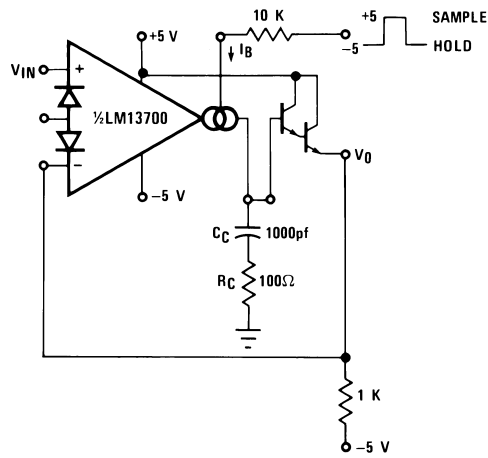

Figure 43. Sample-Hold Circuit

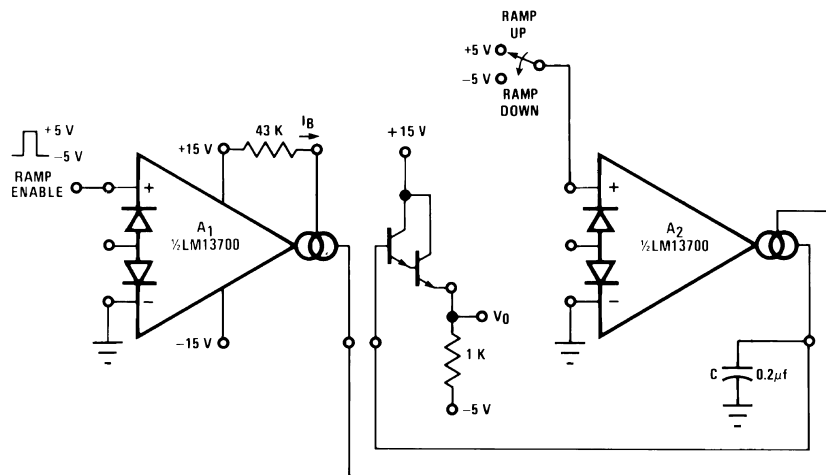

Figure 44. Ramp and Hold

System Examples (continued)

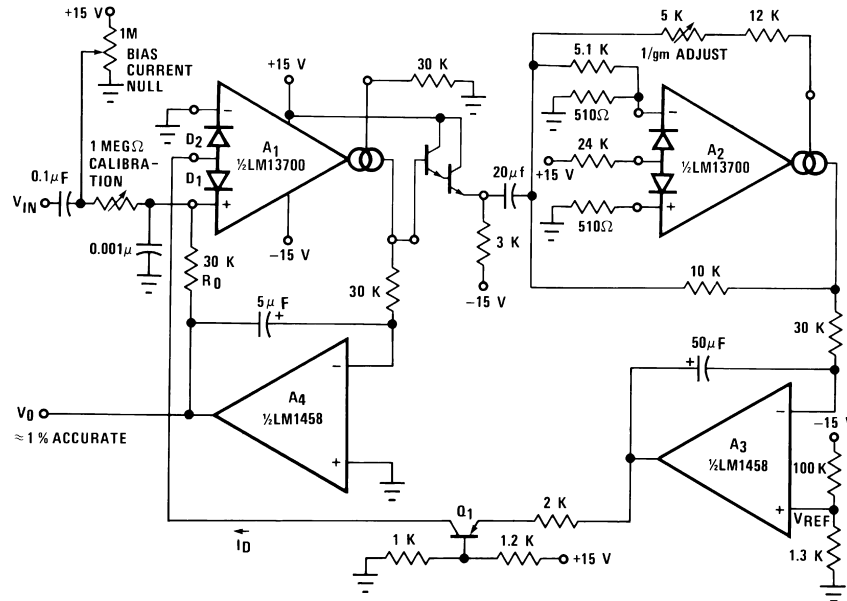

Figure 45. True RMS Converter

The circuit of Figure 46 is a voltage reference of variable Temperature Coefficient. The 100-kΩ potentiometer adjusts the output voltage which has a positive TC above 1.2 V, zero TC at about 1.2 V, and negative TC below 1.2 V. This is accomplished by balancing the TC of the A2 transfer function against the complementary TC of D1.

The wide dynamic range of the LM13700 allows easy control of the output pulse width in the Pulse Width Modulator of Figure 47.

For generating I_{ABC} over a range of 4 to 6 decades of current, the system of Figure 48 provides a logarithmic current out for a linear voltage in.

Since the closed-loop configuration ensures that the input to A2 is held equal to 0 V, the output current of A1 is equal to $I_3 = -V_C/R_C$.

The differential voltage between Q1 and Q2 is attenuated by the R1,R2 network so that A1 may be assumed to be operating within its linear range. From Equation 5, the input voltage to A1 is:

$$V_{IN1} = \frac{-2kT I_3}{q I_2} = \frac{-2kT V_C}{q I_2 R_C} \tag{11}$$

The voltage on the base of Q1 is then

$$V_{B1} = \frac{(R_1 + R_2) V_{IN1}}{R_1} \tag{12}$$

The ratio of the Q1 and Q2 collector currents is defined by:

$$V_{B1} = \frac{kT}{q} \ln \frac{I_{C2}}{I_{C1}} \approx \frac{kT}{q} \ln \frac{I_{ABC}}{I_1} \tag{13}$$

Combining and solving for I_{ABC} yields:

$$I_{ABC} = I_1 \exp \frac{2(R_1 + R_2) V_C}{R_1 I_2 R_C} \tag{14}$$

This logarithmic current is used to bias the circuit of Figure 22 to provide temperature independent stereo attenuation characteristic.

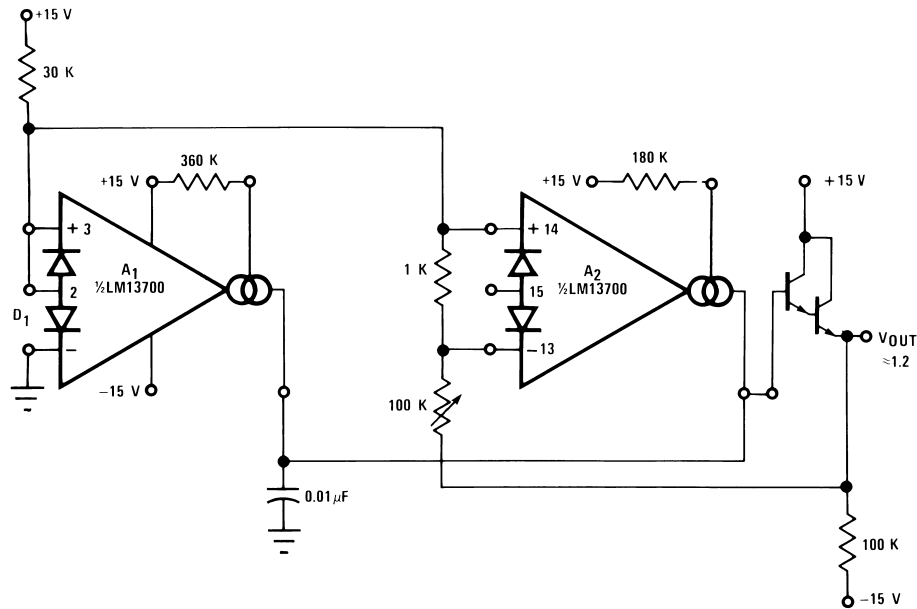
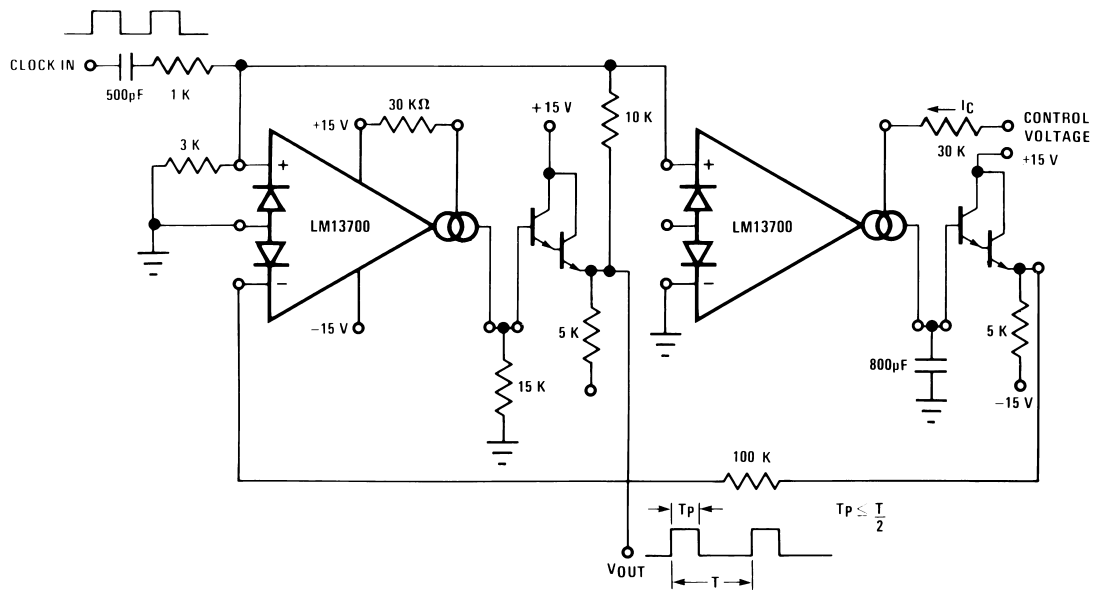
System Examples (continued)

Figure 46. Delta VBE Reference

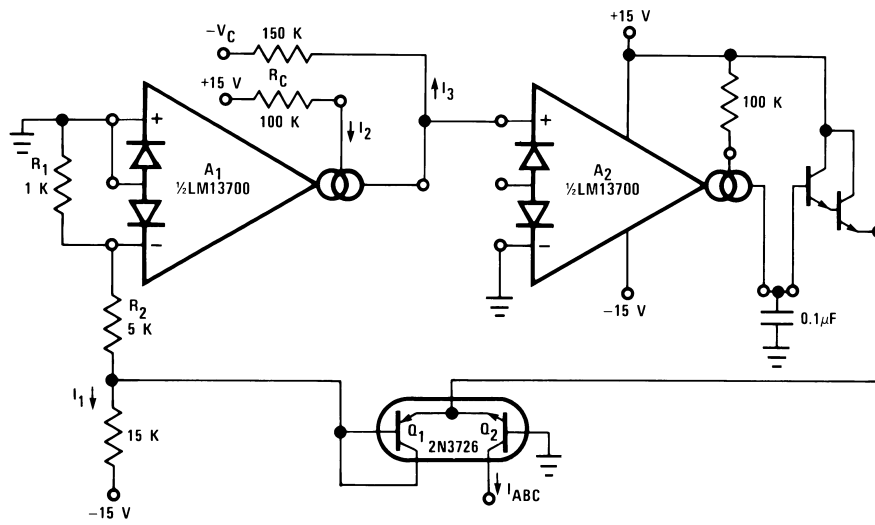
Figure 47. Pulse Width Modulator

System Examples (continued)



$$I_{ABC} = I_1 \exp \frac{-C I_3}{I_2}$$

Figure 48. Logarithmic Current Source

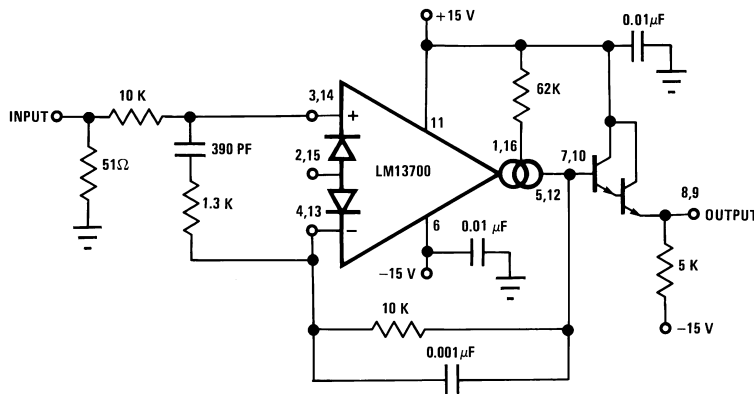

Figure 49. Unity Gain Follower

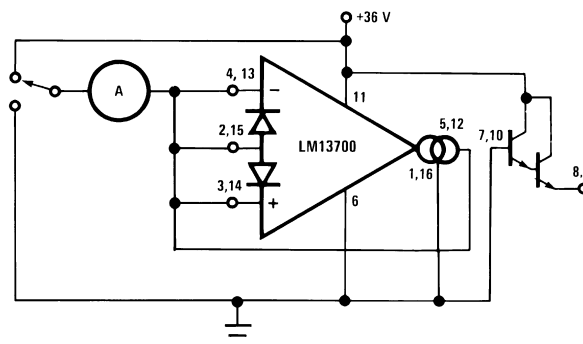

Figure 50. Leakage Current Test Circuit

System Examples (continued)

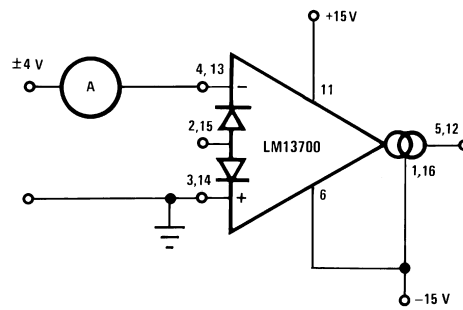

Figure 51. Differential Input Current Test Circuit

9 Power Supply Recommendations

The LM13700 can operate with either a single-ended supply or a dual supplies. The supplies should be low impedance sources with sufficient bypassing. Use of low-ESR sufficiently rated voltage ceramic capacitors is recommended. When bypassing dual supply configurations, the supply bypass capacitors should couple to ground.

10 Layout

10.1 Layout Guidelines

Place supply bypass capacitors as close to the appropriate supply pins as possible. When multiple bypass capacitors are used, the smallest value capacitor should be closest to the supply pin.

Use of a ground plane to minimize ground impedance and provide constant signal impedance is recommended. Avoid routing signal traces over any gaps in the ground plane.

Feedback components and passives should be placed close to the device pins to minimize parasitic impedances. When using capacitors to limit bandwidth, the capacitor should be closer to the device pin than any ballasting or gain resistors.

10.2 Layout Example

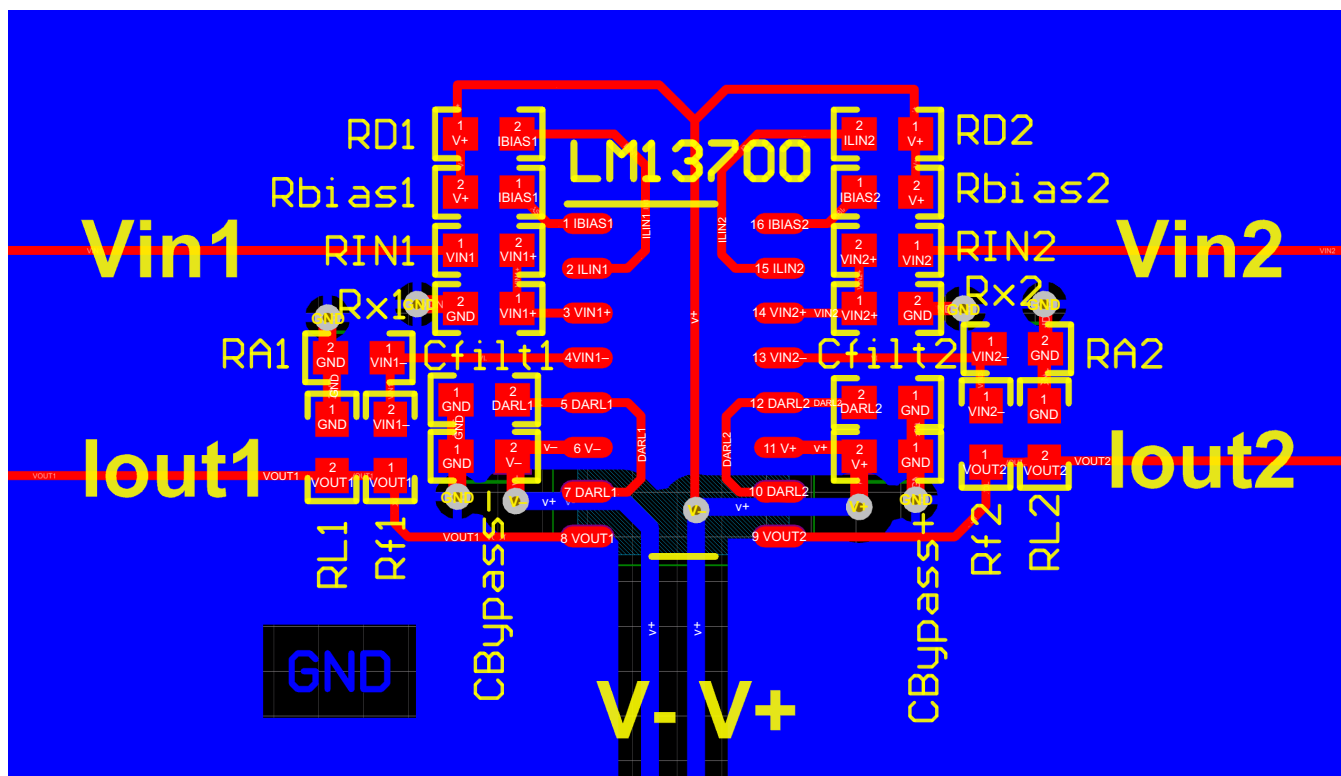

Figure 52. Layout Recommendation

11 Device and Documentation Support

11.1 Community Resources

The following links connect to TI community resources. Linked contents are provided "AS IS" by the respective contributors. They do not constitute TI specifications and do not necessarily reflect TI's views; see TI's [Terms of Use](#).

TI E2E™ Online Community *TI's Engineer-to-Engineer (E2E) Community*. Created to foster collaboration among engineers. At e2e.ti.com, you can ask questions, share knowledge, explore ideas and help solve problems with fellow engineers.

Design Support *TI's Design Support* Quickly find helpful E2E forums along with design support tools and contact information for technical support.

11.2 Trademarks

E2E is a trademark of Texas Instruments.
All other trademarks are the property of their respective owners.

11.3 Electrostatic Discharge Caution



These devices have limited built-in ESD protection. The leads should be shorted together or the device placed in conductive foam during storage or handling to prevent electrostatic damage to the MOS gates.

11.4 Glossary

[SLYZ022](#) — *TI Glossary*.

This glossary lists and explains terms, acronyms, and definitions.

12 Mechanical, Packaging, and Orderable Information

The following pages include mechanical, packaging, and orderable information. This information is the most current data available for the designated devices. This data is subject to change without notice and revision of this document. For browser-based versions of this data sheet, refer to the left-hand navigation.

PACKAGING INFORMATION

Orderable Device	Status (1)	Package Type	Package Drawing	Pins	Package Qty	Eco Plan (2)	Lead/Ball Finish (6)	MSL Peak Temp (3)	Op Temp (°C)	Device Marking (4/5)	Samples
LM13700M/NOPB	ACTIVE	SOIC	D	16	48	Green (RoHS & no Sb/Br)	CU SN	Level-1-260C-UNLIM	0 to 70	LM13700M	Samples
LM13700MX/NOPB	ACTIVE	SOIC	D	16	2500	Green (RoHS & no Sb/Br)	CU SN	Level-1-260C-UNLIM	0 to 70	LM13700M	Samples
LM13700N/NOPB	ACTIVE	PDIP	NFG	16	25	Pb-Free (RoHS)	CU SN	Level-1-NA-UNLIM	0 to 70	LM13700N	Samples

(1) The marketing status values are defined as follows:

ACTIVE: Product device recommended for new designs.

LIFEBUY: TI has announced that the device will be discontinued, and a lifetime-buy period is in effect.

NRND: Not recommended for new designs. Device is in production to support existing customers, but TI does not recommend using this part in a new design.

PREVIEW: Device has been announced but is not in production. Samples may or may not be available.

OBSOLETE: TI has discontinued the production of the device.

(2) **RoHS:** TI defines "RoHS" to mean semiconductor products that are compliant with the current EU RoHS requirements for all 10 RoHS substances, including the requirement that RoHS substance do not exceed 0.1% by weight in homogeneous materials. Where designed to be soldered at high temperatures, "RoHS" products are suitable for use in specified lead-free processes. TI may reference these types of products as "Pb-Free".

RoHS Exempt: TI defines "RoHS Exempt" to mean products that contain lead but are compliant with EU RoHS pursuant to a specific EU RoHS exemption.

Green: TI defines "Green" to mean the content of Chlorine (Cl) and Bromine (Br) based flame retardants meet JS709B low halogen requirements of <=1000ppm threshold. Antimony trioxide based flame retardants must also meet the <=1000ppm threshold requirement.

(3) MSL, Peak Temp. - The Moisture Sensitivity Level rating according to the JEDEC industry standard classifications, and peak solder temperature.

(4) There may be additional marking, which relates to the logo, the lot trace code information, or the environmental category on the device.

(5) Multiple Device Markings will be inside parentheses. Only one Device Marking contained in parentheses and separated by a "~" will appear on a device. If a line is indented then it is a continuation of the previous line and the two combined represent the entire Device Marking for that device.

(6) Lead/Ball Finish - Orderable Devices may have multiple material finish options. Finish options are separated by a vertical ruled line. Lead/Ball Finish values may wrap to two lines if the finish value exceeds the maximum column width.

Important Information and Disclaimer:The information provided on this page represents TI's knowledge and belief as of the date that it is provided. TI bases its knowledge and belief on information provided by third parties, and makes no representation or warranty as to the accuracy of such information. Efforts are underway to better integrate information from third parties. TI has taken and continues to take reasonable steps to provide representative and accurate information but may not have conducted destructive testing or chemical analysis on incoming materials and chemicals. TI and TI suppliers consider certain information to be proprietary, and thus CAS numbers and other limited information may not be available for release.

In no event shall TI's liability arising out of such information exceed the total purchase price of the TI part(s) at issue in this document sold by TI to Customer on an annual basis.

TAPE AND REEL INFORMATION



QUADRANT ASSIGNMENTS FOR PIN 1 ORIENTATION IN TAPE



*All dimensions are nominal

Device	Package Type	Package Drawing	Pins	SPQ	Reel Diameter (mm)	Reel Width W1 (mm)	A0 (mm)	B0 (mm)	K0 (mm)	P1 (mm)	W (mm)	Pin1 Quadrant
LM13700MX/NOPB	SOIC	D	16	2500	330.0	16.4	6.5	10.3	2.3	8.0	16.0	Q1

TAPE AND REEL BOX DIMENSIONS



*All dimensions are nominal

Device	Package Type	Package Drawing	Pins	SPQ	Length (mm)	Width (mm)	Height (mm)
LM13700MX/NOPB	SOIC	D	16	2500	367.0	367.0	35.0

N0016E

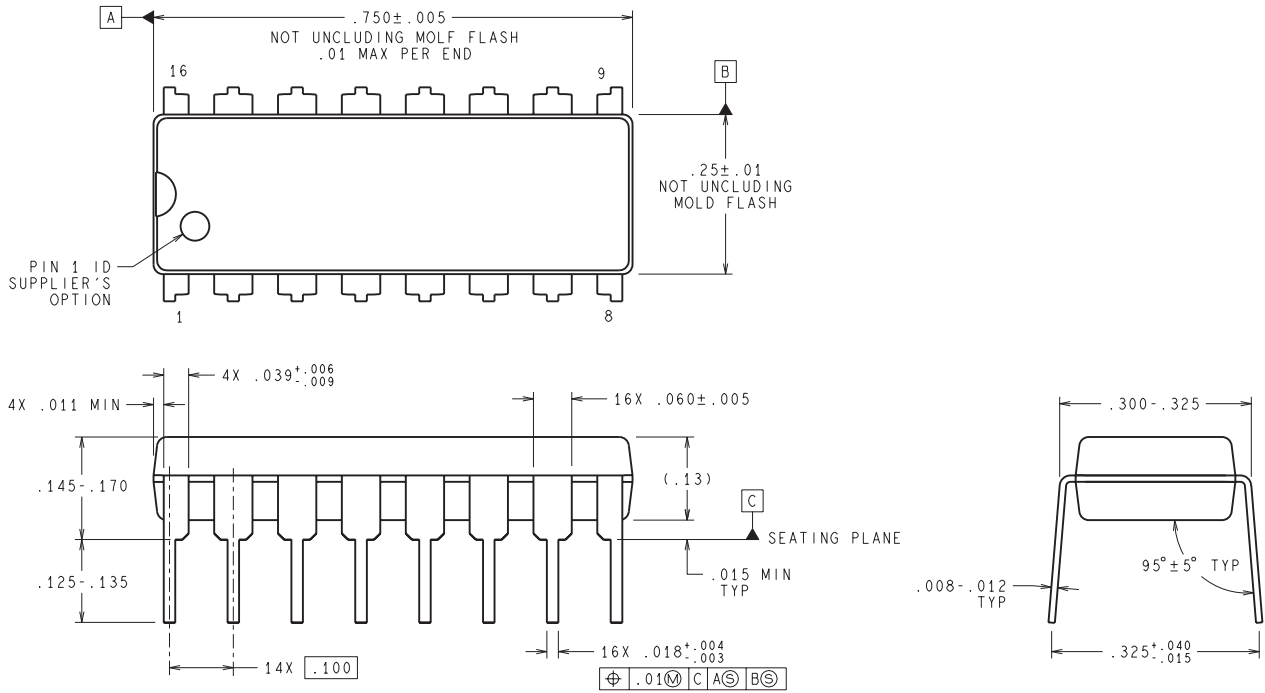

DIMENSIONS ARE IN INCHES
DIMENSIONS IN () FOR REFERENCE ONLY



N16E (Rev G)

D (R-PDSO-G16)

PLASTIC SMALL OUTLINE



4040047-6/M 06/11

- NOTES:
- A. All linear dimensions are in inches (millimeters).
 - B. This drawing is subject to change without notice.
 -  Body length does not include mold flash, protrusions, or gate burrs. Mold flash, protrusions, or gate burrs shall not exceed 0.006 (0,15) each side.
 -  Body width does not include interlead flash. Interlead flash shall not exceed 0.017 (0,43) each side.
 - E. Reference JEDEC MS-012 variation AC.

IMPORTANT NOTICE AND DISCLAIMER

TI PROVIDES TECHNICAL AND RELIABILITY DATA (INCLUDING DATASHEETS), DESIGN RESOURCES (INCLUDING REFERENCE DESIGNS), APPLICATION OR OTHER DESIGN ADVICE, WEB TOOLS, SAFETY INFORMATION, AND OTHER RESOURCES "AS IS" AND WITH ALL FAULTS, AND DISCLAIMS ALL WARRANTIES, EXPRESS AND IMPLIED, INCLUDING WITHOUT LIMITATION ANY IMPLIED WARRANTIES OF MERCHANTABILITY, FITNESS FOR A PARTICULAR PURPOSE OR NON-INFRINGEMENT OF THIRD PARTY INTELLECTUAL PROPERTY RIGHTS.

These resources are intended for skilled developers designing with TI products. You are solely responsible for (1) selecting the appropriate TI products for your application, (2) designing, validating and testing your application, and (3) ensuring your application meets applicable standards, and any other safety, security, or other requirements. These resources are subject to change without notice. TI grants you permission to use these resources only for development of an application that uses the TI products described in the resource. Other reproduction and display of these resources is prohibited. No license is granted to any other TI intellectual property right or to any third party intellectual property right. TI disclaims responsibility for, and you will fully indemnify TI and its representatives against, any claims, damages, costs, losses, and liabilities arising out of your use of these resources.

TI's products are provided subject to TI's Terms of Sale (www.ti.com/legal/termsofsale.html) or other applicable terms available either on ti.com or provided in conjunction with such TI products. TI's provision of these resources does not expand or otherwise alter TI's applicable warranties or warranty disclaimers for TI products.

Mailing Address: Texas Instruments, Post Office Box 655303, Dallas, Texas 75265
Copyright © 2018, Texas Instruments Incorporated

Looking for pricing, stock, or lifecycle information?

Click below to explore more details on WIN SOURCE:

 [View LM13700MX/NOPB on WIN SOURCE](#)

 [Texas Instruments](#) Information

Optimize Your Supply Chain with WIN SOURCE Solutions

-  Global Sourcing Solution
-  Obsolete Management
-  Cost Control Management
-  Shortage Management
-  Alternative Solution
-  Excess Inventory Management