



THE DATASHEET OF LM148J



LM148/LM248/LM348 Quad 741 Op Amps

 Check for Samples: [LM148-N](#), [LM248-N](#), [LM348-N](#)

FEATURES

- 741 Op Amp Operating Characteristics
- Class AB Output Stage—No Crossover Distortion
- Pin Compatible With the LM124
- Overload Protection for Inputs and Outputs
- Low Supply Current Drain: 0.6 mA/Amplifier
- Low Input Offset Voltage: 1 mV
- Low Input Offset Current: 4 nA
- Low Input Bias Current 30 nA
- High Degree of Isolation Between Amplifiers: 120 dB
- Gain Bandwidth Product
 - LM148 (Unity Gain): 1.0 MHz

DESCRIPTION

The LM148 series is a true quad 741. It consists of four independent, high gain, internally compensated, low power operational amplifiers which have been designed to provide functional characteristics identical to those of the familiar 741 operational amplifier. In addition the total supply current for all four amplifiers is comparable to the supply current of a single 741 type op amp. Other features include input offset currents and input bias current which are much less than those of a standard 741. Also, excellent isolation between amplifiers has been achieved by independently biasing each amplifier and using layout techniques which minimize thermal coupling.

The LM148 can be used anywhere multiple 741 or 1558 type amplifiers are being used and in applications where amplifier matching or high packing density is required. For lower power refer to LF444.

Schematic Diagram

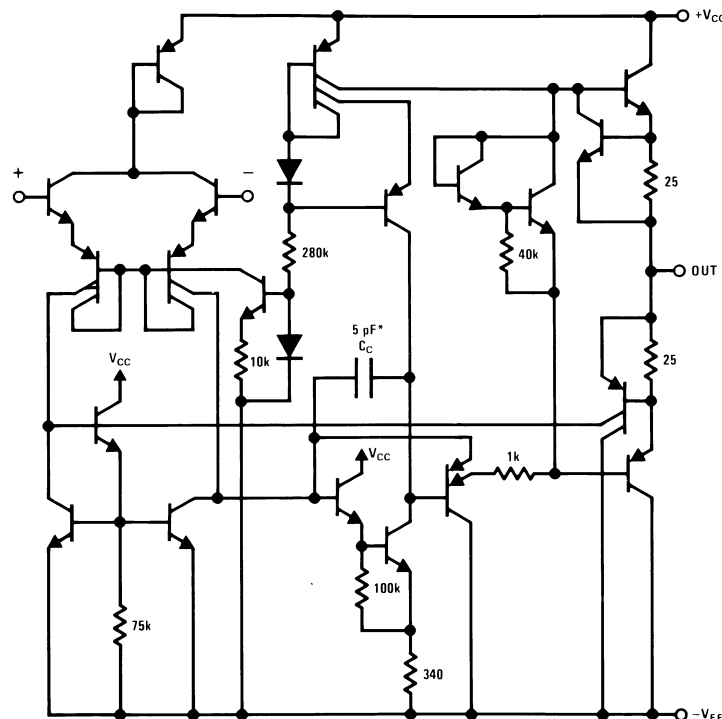

* 1 pF in the LM149



Please be aware that an important notice concerning availability, standard warranty, and use in critical applications of Texas Instruments semiconductor products and disclaimers thereto appears at the end of this data sheet.

All trademarks are the property of their respective owners.



These devices have limited built-in ESD protection. The leads should be shorted together or the device placed in conductive foam during storage or handling to prevent electrostatic damage to the MOS gates.

Absolute Maximum Ratings⁽¹⁾⁽²⁾

	LM148	LM248	LM348	
Supply Voltage	±22V	±18V	±18V	
Differential Input Voltage	±44V	±36V	±36V	
Output Short Circuit Duration ⁽³⁾	Continuous	Continuous	Continuous	
Power Dissipation (P _d at 25°C) and Thermal Resistance (θ _{J(A)}) ⁽⁴⁾				
PDIP (NFF) P _d	—	—	750 mW	
θ _{JA}	—	—	100°C/W	
CDIP (J) P _d	1100 mW	800 mW	700 mW	
θ _{JA}	110°C/W	110°C/W	110°C/W	
Maximum Junction Temperature (T _{JMAX})	150°C	110°C	100°C	
Operating Temperature Range	-55°C ≤ T _A ≤ +125°C	-25°C ≤ T _A ≤ +85°C	0°C ≤ T _A ≤ +70°C	
Storage Temperature Range	-65°C to +150°C	-65°C to +150°C	-65°C to +150°C	
Lead Temperature (Soldering, 10 sec.) Ceramic	300°C	300°C	300°C	
Lead Temperature (Soldering, 10 sec.) Plastic			260°C	
Soldering Information				
Dual-In-Line Package	Soldering (10 seconds)	260°C	260°C	260°C
Small Outline Package	Vapor Phase (60 seconds)	215°C	215°C	215°C
	Infrared (15 seconds)	220°C	220°C	220°C
ESD tolerance ⁽⁵⁾	500V	500V	500V	

- (1) Refer to RETS 148X for LM148 military specifications.
- (2) If Military/Aerospace specified devices are required, please contact the TI Sales Office/Distributors for availability and specifications.
- (3) Any of the amplifier outputs can be shorted to ground indefinitely; however, more than one should not be simultaneously shorted as the maximum junction temperature will be exceeded.
- (4) The maximum power dissipation for these devices must be derated at elevated temperatures and is dictated by T_{JMAX}, θ_{JA}, and the ambient temperature, T_A. The maximum available power dissipation at any temperature is P_d = (T_{JMAX} - T_A)/θ_{JA} or the 25°C P_{DMAX}, whichever is less.
- (5) Human body model, 1.5 kΩ in series with 100 pF.

Electrical Characteristics

These specifications apply for V_S = ±15V and over the absolute maximum operating temperature range (T_L ≤ T_A ≤ T_H) unless otherwise noted.

Parameter	Conditions	LM148			LM248			LM348			Units
		Min	Typ	Max	Min	Typ	Max	Min	Typ	Max	
Input Offset Voltage	T _A = 25°C, R _S ≤ 10 kΩ		1.0	5.0		1.0	6.0		1.0	6.0	mV
Input Offset Current	T _A = 25°C		4	25		4	50		4	50	nA
Input Bias Current	T _A = 25°C		30	100		30	200		30	200	nA
Input Resistance	T _A = 25°C	0.8	2.5		0.8	2.5		0.8	2.5		MΩ
Supply Current All Amplifiers	T _A = 25°C, V _S = ±15V		2.4	3.6		2.4	4.5		2.4	4.5	mA
Large Signal Voltage Gain	T _A = 25°C, V _S = ±15V V _{OUT} = ±10V, R _L ≥ 2 kΩ	50	160		25	160		25	160		V/mV
Amplifier to Amplifier Coupling	T _A = 25°C, f = 1 Hz to 20 kHz (Input Referred) See Crosstalk Test Circuit		-120			-120			-120		dB
Small Signal Bandwidth	T _A = 25°C, LM148 Series		1.0			1.0			1.0		MHz
Phase Margin	T _A = 25°C, LM148 Series (A _V = 1)		60			60			60		degrees

Electrical Characteristics (continued)

These specifications apply for $V_S = \pm 15V$ and over the absolute maximum operating temperature range ($T_L \leq T_A \leq T_H$) unless otherwise noted.

Parameter	Conditions	LM148			LM248			LM348			Units
		Min	Typ	Max	Min	Typ	Max	Min	Typ	Max	
Slew Rate	$T_A = 25^\circ C$, LM148 Series ($A_V = 1$)		0.5			0.5			0.5		V/ μs
Output Short Circuit Current	$T_A = 25^\circ C$		25			25			25		mA
Input Offset Voltage	$R_S \leq 10\text{ k}\Omega$			6.0			7.5			7.5	mV
Input Offset Current				75			125			100	nA
Input Bias Current				325			500			400	nA
Large Signal Voltage Gain	$V_S = \pm 15V$, $V_{OUT} = \pm 10V$, $R_L > 2\text{ k}\Omega$	25			15			15			V/mV
Output Voltage Swing	$V_S = \pm 15V$, $R_L = 10\text{ k}\Omega$	± 12	± 13		± 12	± 13		± 12	± 13		V
	$R_L = 2\text{ k}\Omega$	± 10	± 12		± 10	± 12		± 10	± 12		V
Input Voltage Range	$V_S = \pm 15V$	± 12			± 12			± 12			V
Common-Mode Rejection Ratio	$R_S \leq 10\text{ k}\Omega$	70	90		70	90		70	90		dB
Supply Voltage Rejection	$R_S \leq 10\text{ k}\Omega$, $\pm 5V \leq V_S \leq \pm 15V$	77	96		77	96		77	96		dB

CROSS TALK TEST CIRCUIT

$V_S = \pm 15V$

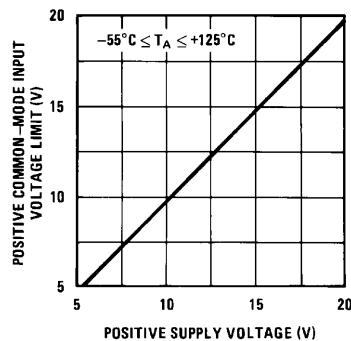
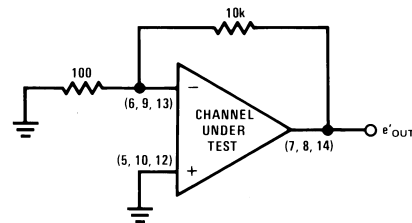
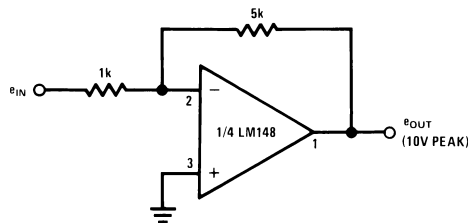

Typical Performance Characteristics

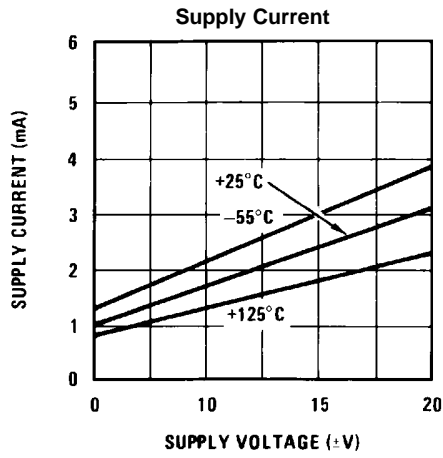

Figure 1.

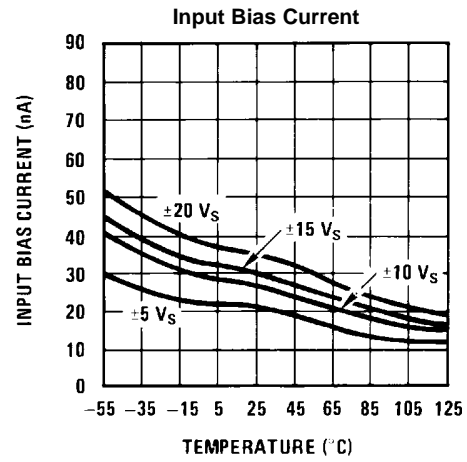

Figure 2.

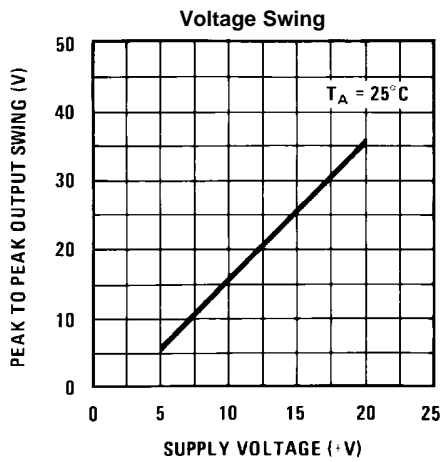

Figure 3.

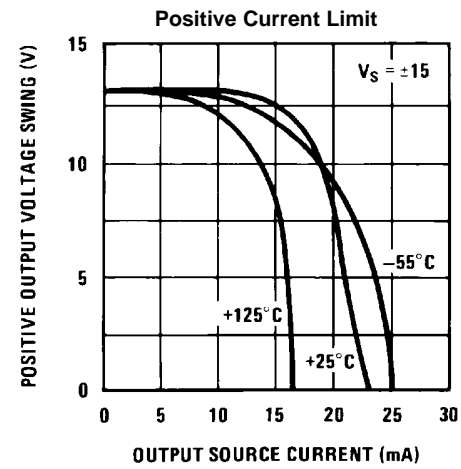

Figure 4.

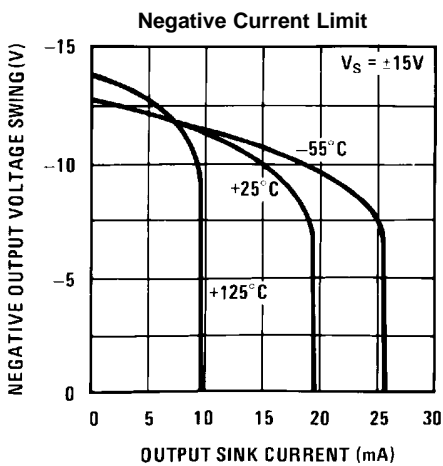

Figure 5.

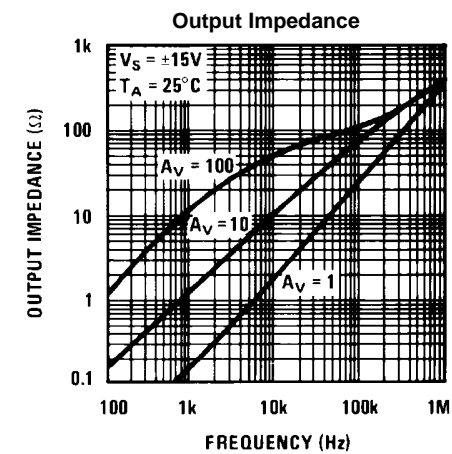

Figure 6.

Typical Performance Characteristics (continued)

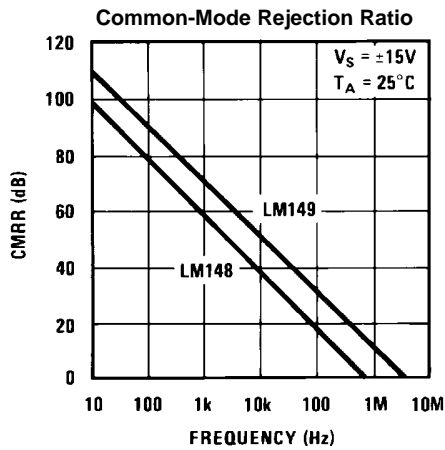

Figure 7.

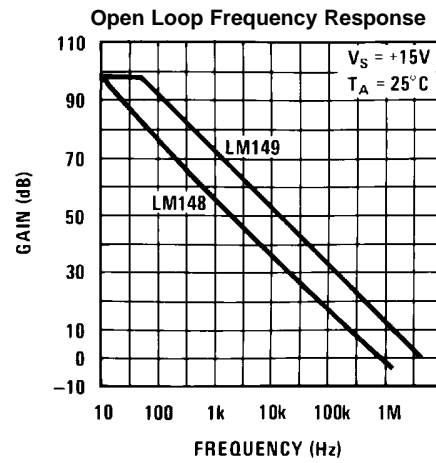

Figure 8.

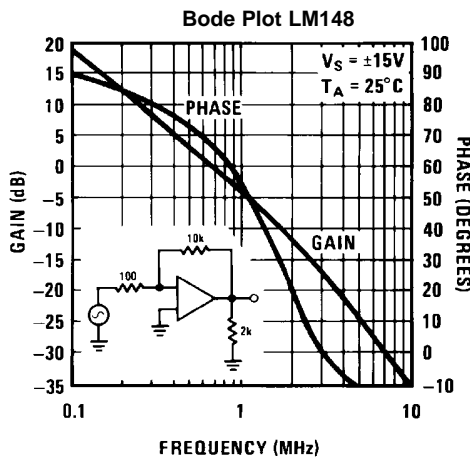

Figure 9.

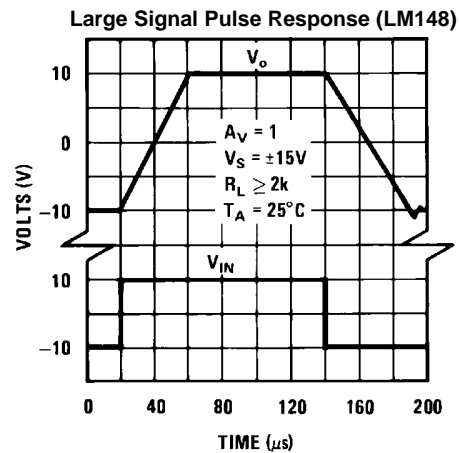

Figure 10.

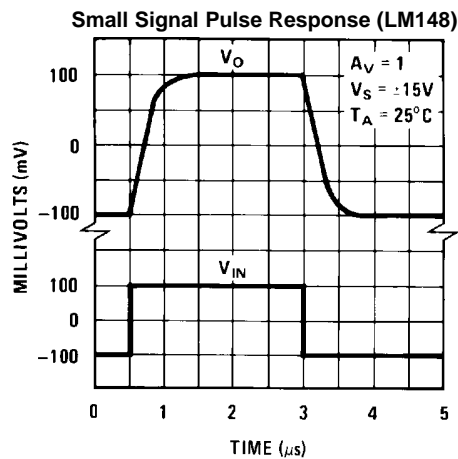

Figure 11.

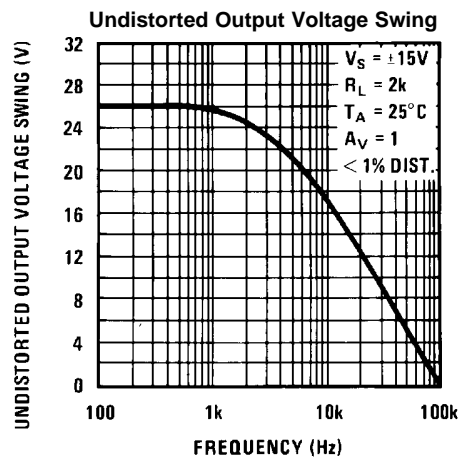

Figure 12.

Typical Performance Characteristics (continued)

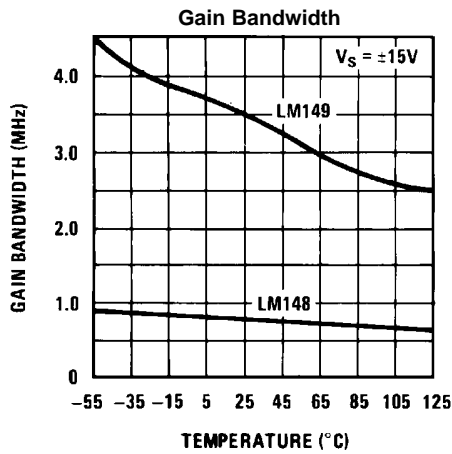

Figure 13.

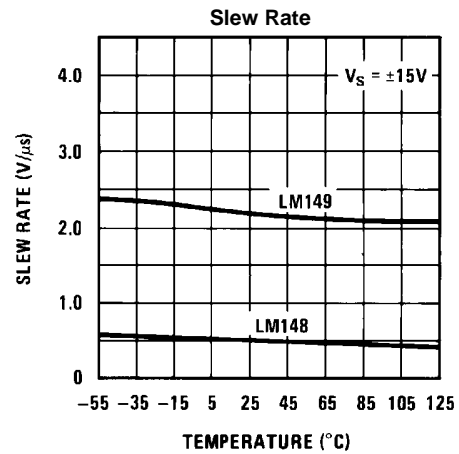

Figure 14.

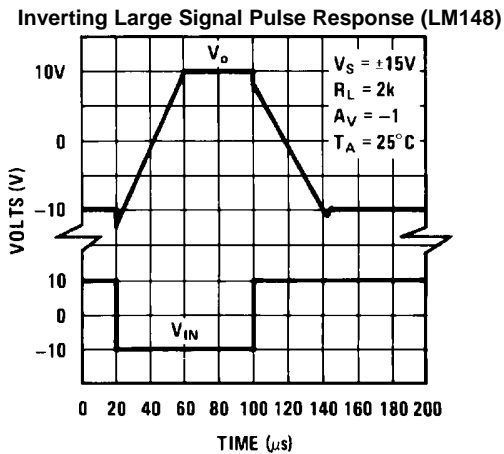

Figure 15.

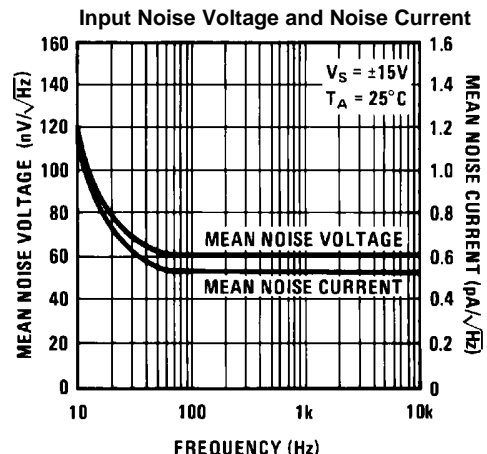

Figure 16.

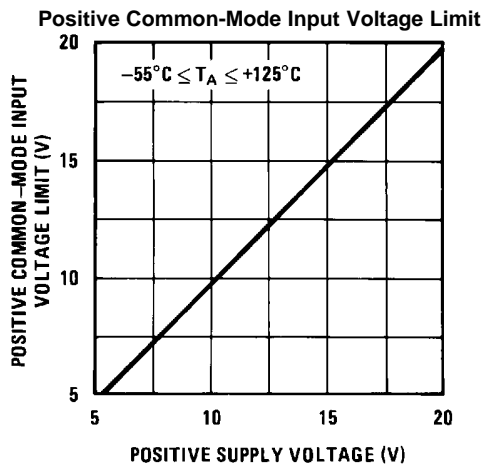

Figure 17.

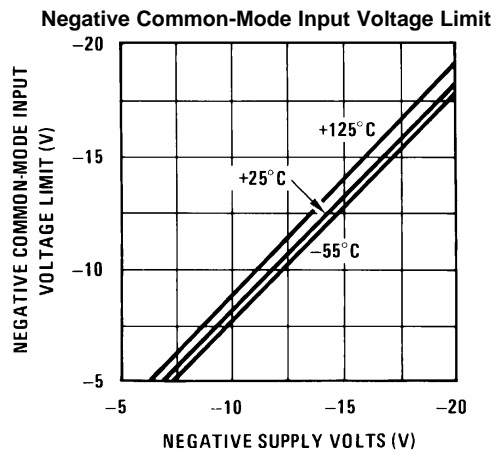

Figure 18.

APPLICATION HINTS

The LM148 series are quad low power 741 op amps. In the proliferation of quad op amps, these are the first to offer the convenience of familiar, easy to use operating characteristics of the 741 op amp. In those applications where 741 op amps have been employed, the LM148 series op amps can be employed directly with no change in circuit performance.

The package pin-outs are such that the inverting input of each amplifier is adjacent to its output. In addition, the amplifier outputs are located in the corners of the package which simplifies PC board layout and minimizes package related capacitive coupling between amplifiers.

The input characteristics of these amplifiers allow differential input voltages which can exceed the supply voltages. In addition, if either of the input voltages is within the operating common-mode range, the phase of the output remains correct. If the negative limit of the operating common-mode range is exceeded at both inputs, the output voltage will be positive. For input voltages which greatly exceed the maximum supply voltages, either differentially or common-mode, resistors should be placed in series with the inputs to limit the current.

Like the LM741, these amplifiers can easily drive a 100 pF capacitive load throughout the entire dynamic output voltage and current range. However, if very large capacitive loads must be driven by a non-inverting unity gain amplifier, a resistor should be placed between the output (and feedback connection) and the capacitance to reduce the phase shift resulting from the capacitive loading.

The output current of each amplifier in the package is limited. Short circuits from an output to either ground or the power supplies will not destroy the unit. However, if multiple output shorts occur simultaneously, the time duration should be short to prevent the unit from being destroyed as a result of excessive power dissipation in the IC chip.

As with most amplifiers, care should be taken lead dress, component placement and supply decoupling in order to ensure stability. For example, resistors from the output to an input should be placed with the body close to the input to minimize "pickup" and maximize the frequency of the feedback pole which capacitance from the input to ground creates.

A feedback pole is created when the feedback around any amplifier is resistive. The parallel resistance and capacitance from the input of the device (usually the inverting input) to AC ground set the frequency of the pole. In many instances the frequency of this pole is much greater than the expected 3 dB frequency of the closed loop gain and consequently there is negligible effect on stability margin. However, if the feedback pole is less than approximately six times the expected 3 dB frequency a lead capacitor should be placed from the output to the input of the op amp. The value of the added capacitor should be such that the RC time constant of this capacitor and the resistance it parallels is greater than or equal to the original feedback pole time constant.

Typical Applications—LM148

Figure 19. One Decade Low Distortion Sinewave Generator

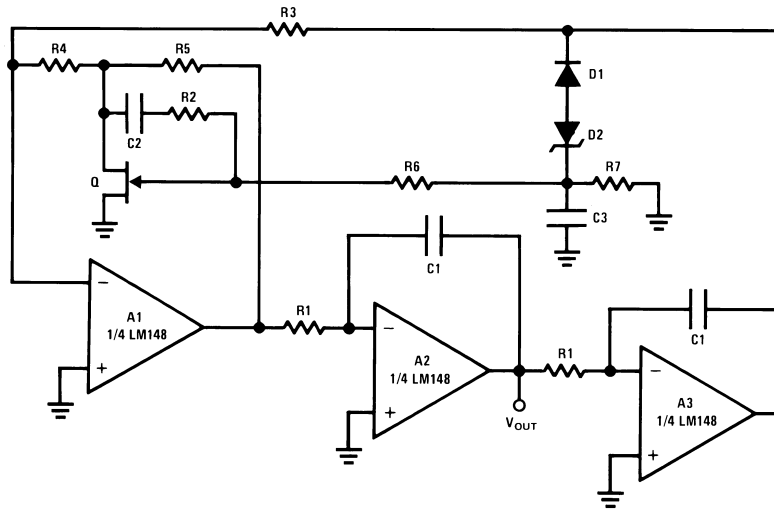

$$f = \frac{1}{2\pi R_1 C_1} \times \sqrt{K}, K = \frac{R_4 R_5}{R_3} \left(\frac{1}{r_{DS}} + \frac{1}{R_4} + \frac{1}{R_5} \right), r_{DS} \approx \frac{R_{ON}}{\left(1 - \frac{V_{GS}}{V_P} \right)^{1/2}}$$

$f_{MAX} = 5 \text{ kHz}$, $THD \leq 0.03\%$
 $R_1 = 100\text{k pot}$, $C_1 = 0.0047 \mu\text{F}$, $C_2 = 0.01 \mu\text{F}$, $C_3 = 0.1 \mu\text{F}$, $R_2 = R_6 = R_7 = 1\text{M}$,
 $R_3 = 5.1\text{k}$, $R_4 = 12\Omega$, $R_5 = 240\Omega$, $Q = \text{NS5102}$, $D_1 = 1\text{N914}$, $D_2 = 3.6\text{V avalanche diode (ex. LM103)}$, $V_S = \pm 15\text{V}$

A simpler version with some distortion degradation at high frequencies can be made by using A1 as a simple inverting amplifier, and by putting back to back zeners in the feedback loop of A3.

Figure 20. Low Cost Instrumentation Amplifier

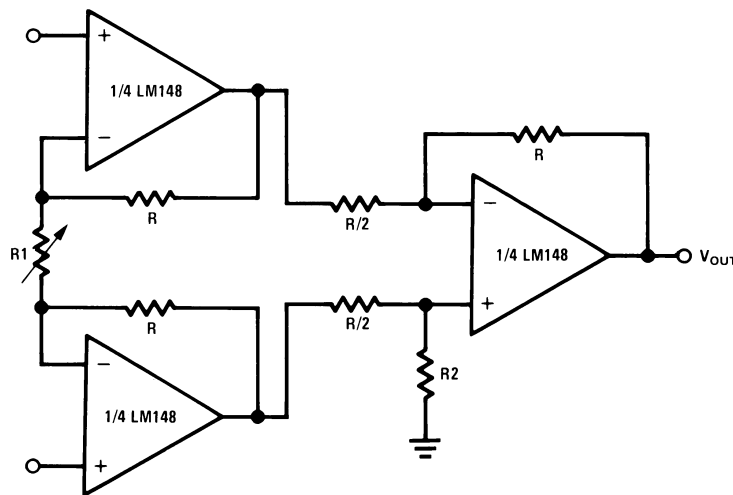

$$V_{OUT} = 2 \left(\frac{2R}{R_1} + 1 \right), V_S - 3\text{V} \leq V_{IN CM} \leq V_S^+ - 3\text{V}$$

$V_S = \pm 15\text{V}$
 $R = R_2$, trim R_2 to boost CMRR

Figure 21. Low Drift Peak Detector with Bias Current Compensation

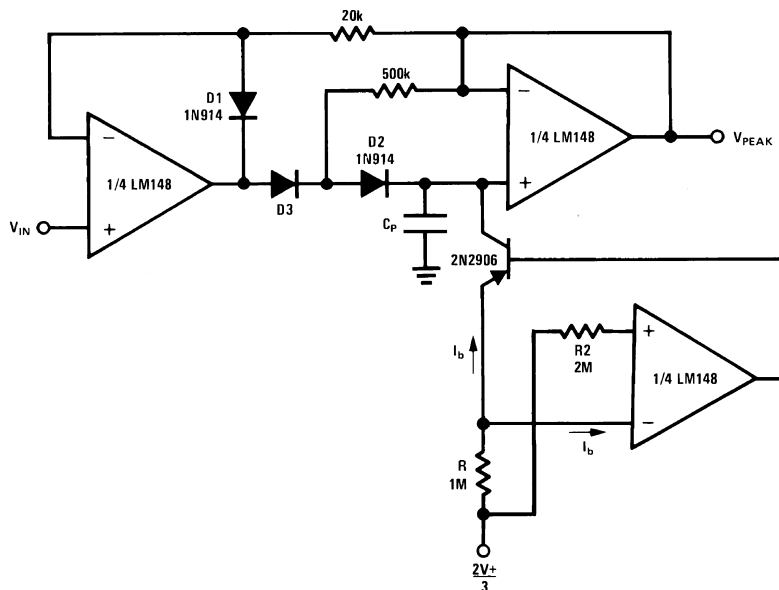

Adjust R for minimum drift
D3 low leakage diode
D1 added to improve speed
 $V_S = \pm 15V$

Figure 22. Universal State-Variable Filter

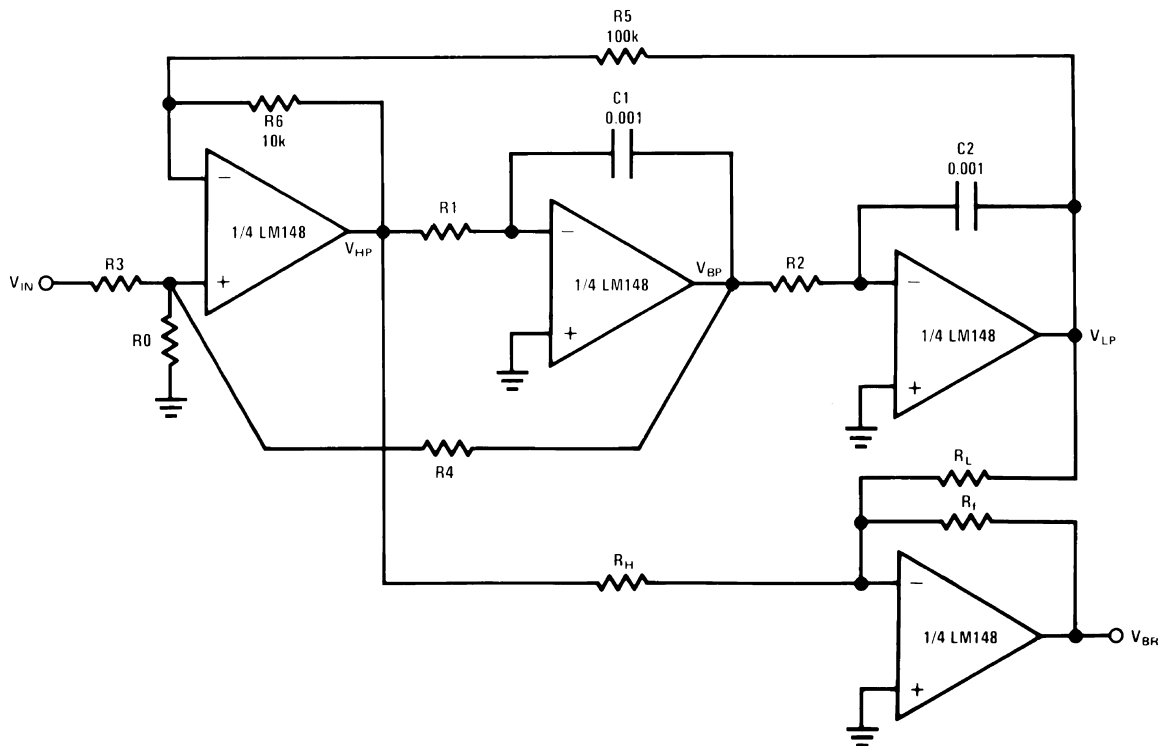

Tune Q through R0,
For predictable results: $f_0 Q \leq 4 \times 10^4$
Use Band Pass output to tune for Q

$$\frac{V(s)}{V_{IN}(s)} = \frac{N(s)}{D(s)}, D(s) = S^2 + \frac{S\omega_0}{Q} + \omega_0^2$$

$$N_{HP}(s) = S^2 H_{OHP}, N_{BP}(s) = \frac{-s\omega_0 H_{OBP}}{Q}, N_{LP} = \omega_0^2 H_{OLP}$$

$$f_o = \frac{1}{2\pi} \sqrt{\frac{R_6}{R_5}} \sqrt{\frac{1}{t_1 t_2}}, t_i = R_i C_i, Q = \left(\frac{1 + R_4/R_3 + R_4/R_0}{1 + R_6/R_5} \right) \left(\frac{R_6 t_1}{R_5 t_2} \right)^{1/2}$$

$$f_{NOTCH} = \frac{1}{2\pi} \left(\frac{R_H}{R_L t_1 t_2} \right)^{1/2}, H_{OHP} = \frac{1 + R_6/R_5}{1 + R_3/R_0 + R_3/R_4}, H_{OBP} = \frac{1 + R_4/R_3 + R_4/R_0}{1 + R_3/R_0 + R_3/R_4}$$

$$H_{OLP} = \frac{1 + R_5/R_6}{1 + R_3/R_0 + R_3/R_4}$$

Figure 23. A 1 kHz 4 Pole Butterworth

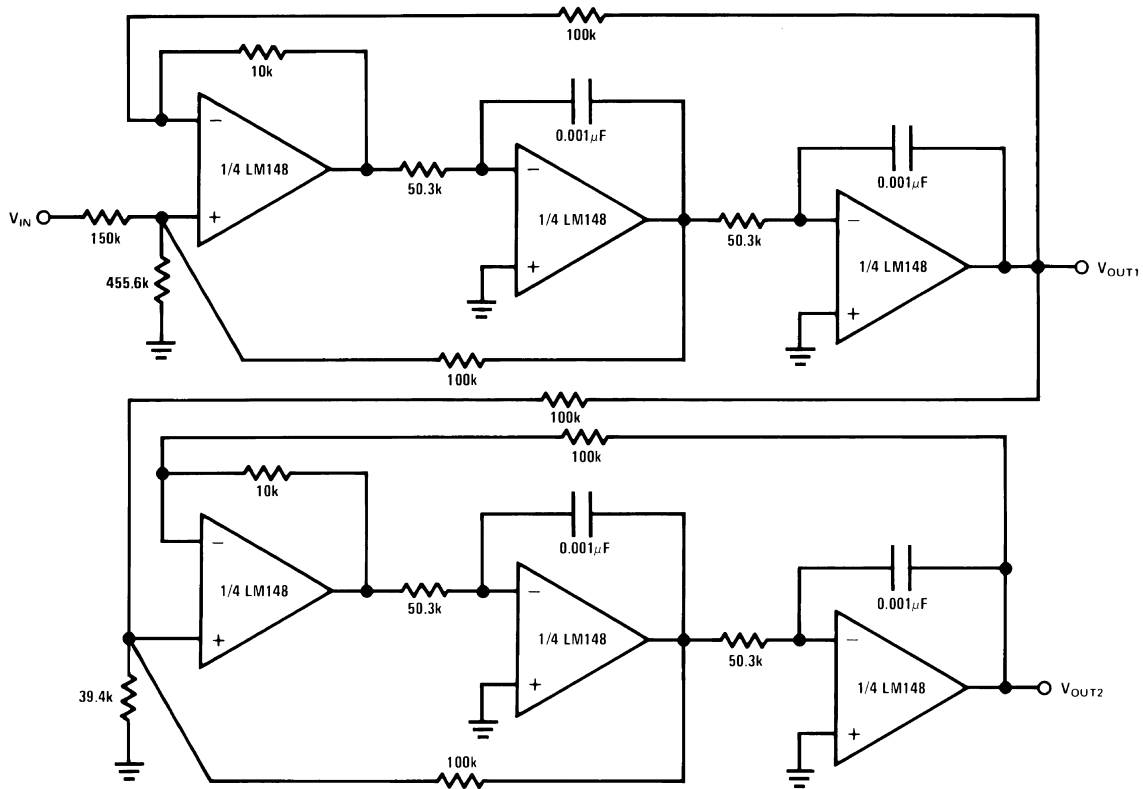

Use general equations, and tune each section separately

$Q_{1stSECTION} = 0.541, Q_{2ndSECTION} = 1.306$

The response should have 0 dB peaking

Figure 24. A 3 Amplifier Bi-Quad Notch Filter

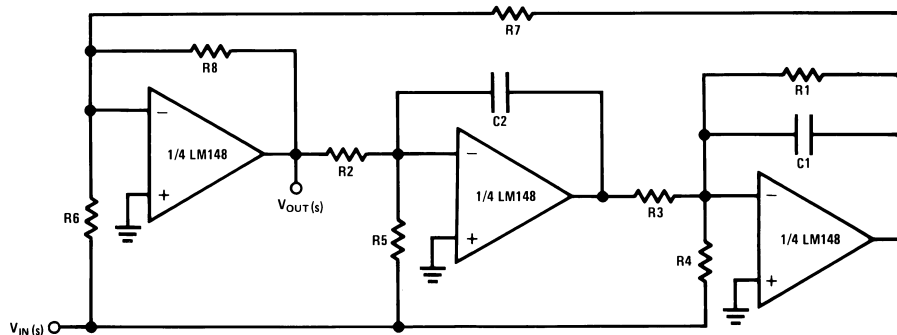

$$Q = \sqrt{\frac{R8}{R7}} \times \frac{R1C1}{\sqrt{R3C2R2C1}}, f_o = \frac{1}{2\pi} \sqrt{\frac{R8}{R7}} \times \frac{1}{\sqrt{R2R3C1C2}}, f_{NOTCH} = \frac{1}{2\pi} \sqrt{\frac{R6}{R3R5R7C1C2}}$$

Necessary condition for notch: $\frac{1}{R6} = \frac{R1}{R4R7}$

EX: $f_{NOTCH} = 3 \text{ kHz}$, $Q = 5$, $R1 = 270\text{k}$, $R2 = R3 = 20\text{k}$, $R4 = 27\text{k}$, $R5 = 20\text{k}$, $R6 = R8 = 10\text{k}$, $R7 = 100\text{k}$, $C1 = C2 = 0.001 \mu\text{F}$
 Better noise performance than the state-space approach.

Figure 25. A 4th Order 1 kHz Elliptic Filter (4 Poles, 4 Zeros)

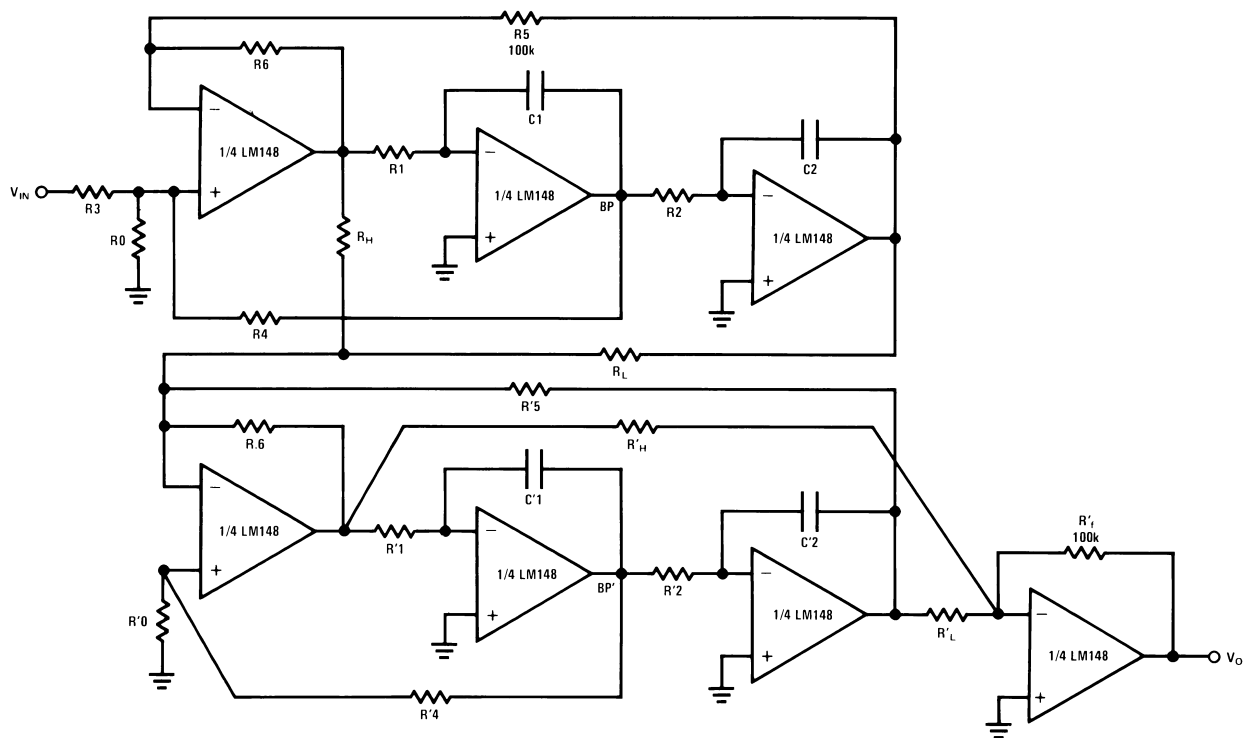

$R1C1 = R2C2 = t$
 $R'1C'1 = R'2C'2 = t'$
 $f_c = 1 \text{ kHz}$, $f_s = 2 \text{ kHz}$, $f_p = 0.543$, $f_z = 2.14$, $Q = 0.841$, $f'_p = 0.987$, $f'_z = 4.92$, $Q' = 4.403$, normalized to ripple BW

$$f = \frac{1}{2\pi R_1 C_1} \times \sqrt{K}, K = \frac{R_4 R_5}{R_3} \left(\frac{1}{r_{DS}} + \frac{1}{R_4} + \frac{1}{R_5} \right), r_{DS} \approx \frac{R_{ON}}{\left(1 - \frac{V_{GS}}{V_P} \right)^{1/2}}$$

Use the BP outputs to tune Q, Q', tune the 2 sections separately

R1 = R2 = 92.6k, R3 = R4 = R5 = 100k, R6 = 10k, R0 = 107.8k, RL = 100k, RH = 155.1k, R'1 = R'2 = 50.9k, R'4 = R'5 = 100k, R'6 = 10k, R'0 = 5.78k, R'L = 100k, R'H = 248.12k, R'f = 100k. All capacitors are 0.001 μF.

Figure 26. Lowpass Response

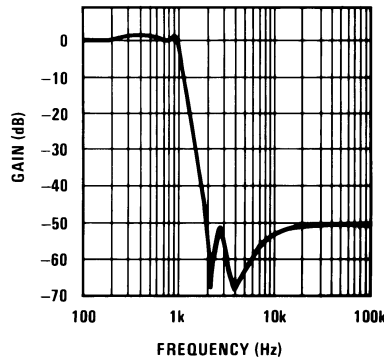

Typical Simulation

Figure 27. LM148, LM741 Macromodel for Computer Simulation

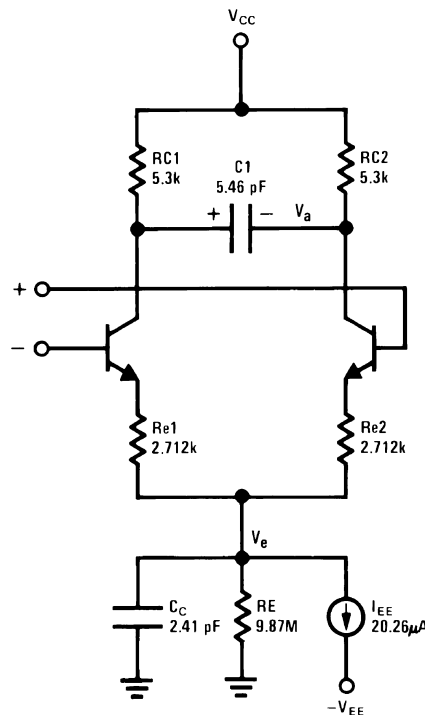

For more details, see IEEE Journal of Solid-State Circuits, Vol. SC-9, No. 6, December 1974

$$o_1 = 112I_S = 8 \times 10^{-16}$$

$$o_2 = 144 \cdot C_2 = 6 \text{ pF for LM149}$$

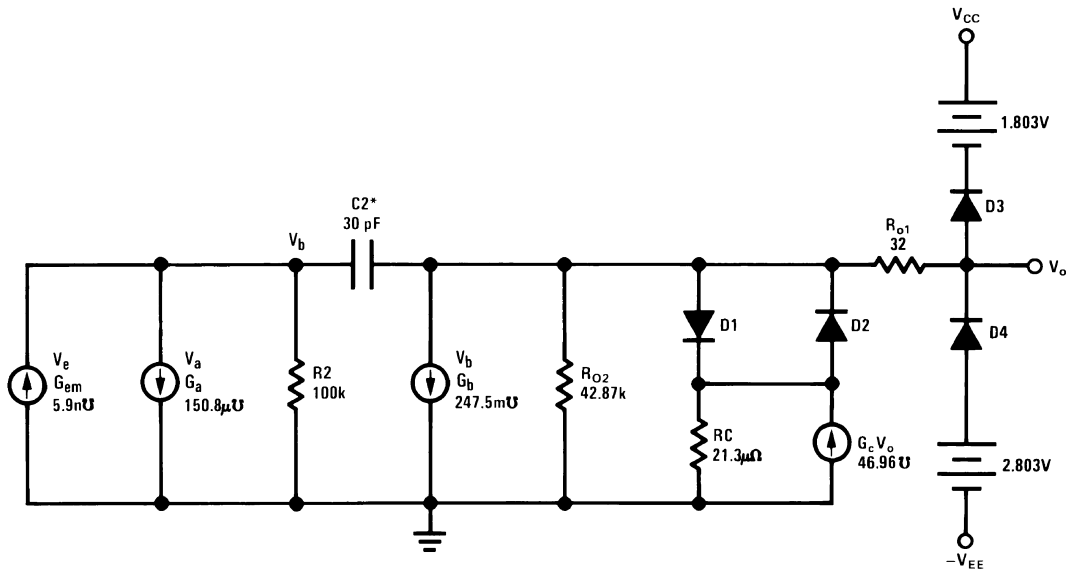

Connection Diagram

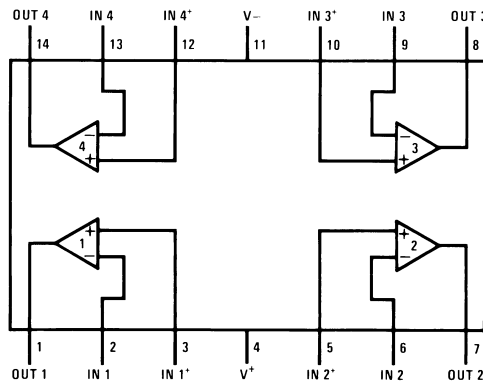



Figure 28. Top View
See Package Number J0014A, D0014A or NFF00014A

REVISION HISTORY

Changes from Revision D (March 2013) to Revision E	Page
• Changed layout of National Data Sheet to TI format	13

PACKAGING INFORMATION

Orderable Device	Status (1)	Package Type	Package Drawing	Pins	Package Qty	Eco Plan (2)	Lead finish/ Ball material (6)	MSL Peak Temp (3)	Op Temp (°C)	Device Marking (4/5)	Samples
LM148J/PB	ACTIVE	CDIP	J	14	25	Non-RoHS & Green	Call TI	Level-1-NA-UNLIM	-55 to 125	LM148J	

(1) The marketing status values are defined as follows:

ACTIVE: Product device recommended for new designs.

LIFEBUY: TI has announced that the device will be discontinued, and a lifetime-buy period is in effect.

NRND: Not recommended for new designs. Device is in production to support existing customers, but TI does not recommend using this part in a new design.

PREVIEW: Device has been announced but is not in production. Samples may or may not be available.

OBSOLETE: TI has discontinued the production of the device.

(2) **RoHS:** TI defines "RoHS" to mean semiconductor products that are compliant with the current EU RoHS requirements for all 10 RoHS substances, including the requirement that RoHS substance do not exceed 0.1% by weight in homogeneous materials. Where designed to be soldered at high temperatures, "RoHS" products are suitable for use in specified lead-free processes. TI may reference these types of products as "Pb-Free".

RoHS Exempt: TI defines "RoHS Exempt" to mean products that contain lead but are compliant with EU RoHS pursuant to a specific EU RoHS exemption.

Green: TI defines "Green" to mean the content of Chlorine (Cl) and Bromine (Br) based flame retardants meet JS709B low halogen requirements of <=100ppm threshold. Antimony trioxide based flame retardants must also meet the <=1000ppm threshold requirement.

(3) MSL, Peak Temp. - The Moisture Sensitivity Level rating according to the JEDEC industry standard classifications, and peak solder temperature.

(4) There may be additional marking, which relates to the logo, the lot trace code information, or the environmental category on the device.

(5) Multiple Device Markings will be inside parentheses. Only one Device Marking contained in parentheses and separated by a "-" will appear on a device. If a line is indented then it is a continuation of the previous line and the two combined represent the entire Device Marking for that device.

(6) Lead finish/Ball material - Orderable Devices may have multiple material finish options. Finish options are separated by a vertical ruled line. Lead finish/Ball material values may wrap to two lines if the finish value exceeds the maximum column width.

Important Information and Disclaimer:The information provided on this page represents TI's knowledge and belief as of the date that it is provided. TI bases its knowledge and belief on information provided by third parties, and makes no representation or warranty as to the accuracy of such information. Efforts are underway to better integrate information from third parties. TI has taken and continues to take reasonable steps to provide representative and accurate information but may not have conducted destructive testing or chemical analysis on incoming materials and chemicals. TI and TI suppliers consider certain information to be proprietary, and thus CAS numbers and other limited information may not be available for release.

In no event shall TI's liability arising out of such information exceed the total purchase price of the TI part(s) at issue in this document sold by TI to Customer on an annual basis.

TUBE

*All dimensions are nominal

Device	Package Name	Package Type	Pins	SPQ	L (mm)	W (mm)	T (μm)	B (mm)
LM148J/PB	J	CDIP	14	25	502	14	11938	4.32

J 14

GENERIC PACKAGE VIEW
CDIP - 5.08 mm max height
CERAMIC DUAL IN LINE PACKAGE



Images above are just a representation of the package family, actual package may vary.
Refer to the product data sheet for package details.

4040083-5/G

J0014A



PACKAGE OUTLINE

CDIP - 5.08 mm max height

CERAMIC DUAL IN LINE PACKAGE



4214771/A 05/2017

NOTES:

1. All controlling linear dimensions are in inches. Dimensions in brackets are in millimeters. Any dimension in brackets or parenthesis are for reference only. Dimensioning and tolerancing per ASME Y14.5M.
2. This drawing is subject to change without notice.
3. This package is hermetically sealed with a ceramic lid using glass frit.
4. Index point is provided on cap for terminal identification only and on press ceramic glass frit seal only.
5. Falls within MIL-STD-1835 and GDIP1-T14.

EXAMPLE BOARD LAYOUT

J0014A

CDIP - 5.08 mm max height

CERAMIC DUAL IN LINE PACKAGE



LAND PATTERN EXAMPLE
NON-SOLDER MASK DEFINED
SCALE: 5X



4214771/A 05/2017

IMPORTANT NOTICE AND DISCLAIMER

TI PROVIDES TECHNICAL AND RELIABILITY DATA (INCLUDING DATA SHEETS), DESIGN RESOURCES (INCLUDING REFERENCE DESIGNS), APPLICATION OR OTHER DESIGN ADVICE, WEB TOOLS, SAFETY INFORMATION, AND OTHER RESOURCES "AS IS" AND WITH ALL FAULTS, AND DISCLAIMS ALL WARRANTIES, EXPRESS AND IMPLIED, INCLUDING WITHOUT LIMITATION ANY IMPLIED WARRANTIES OF MERCHANTABILITY, FITNESS FOR A PARTICULAR PURPOSE OR NON-INFRINGEMENT OF THIRD PARTY INTELLECTUAL PROPERTY RIGHTS.

These resources are intended for skilled developers designing with TI products. You are solely responsible for (1) selecting the appropriate TI products for your application, (2) designing, validating and testing your application, and (3) ensuring your application meets applicable standards, and any other safety, security, regulatory or other requirements.

These resources are subject to change without notice. TI grants you permission to use these resources only for development of an application that uses the TI products described in the resource. Other reproduction and display of these resources is prohibited. No license is granted to any other TI intellectual property right or to any third party intellectual property right. TI disclaims responsibility for, and you will fully indemnify TI and its representatives against, any claims, damages, costs, losses, and liabilities arising out of your use of these resources.



TI's products are provided subject to [TI's Terms of Sale](#) or other applicable terms available either on ti.com or provided in conjunction with such TI products. TI's provision of these resources does not expand or otherwise alter TI's applicable warranties or warranty disclaimers for TI products.

TI objects to and rejects any additional or different terms you may have proposed.

Mailing Address: Texas Instruments, Post Office Box 655303, Dallas, Texas 75265
Copyright © 2022, Texas Instruments Incorporated

Looking for pricing, stock, or lifecycle information?

Click below to explore more details on WIN SOURCE:

-  [View LM148J on WIN SOURCE](#)
-  [Texas Instruments](#) Information

Optimize Your Supply Chain with WIN SOURCE Solutions

-  Global Sourcing Solution
-  Obsolete Management
-  Cost Control Management
-  Shortage Management
-  Alternative Solution
-  Excess Inventory Management