



**THE DATASHEET OF
LM1572MTC-3.3**



LM1572

1.5A, 500kHz Step-down Voltage Regulator

General Description

The LM1572 is a 500kHz step-down (buck) switching voltage regulator capable of driving up to 1.5A in to a load while occupying a very small PCB area. Current Mode Control results in superior transient response and regulation over a wider range of operating conditions. National's advanced analog bipolar, CMOS plus DMOS process enables high efficiency at high switching frequency, and the internal 150mΩ MOSFET switch provides more power from a smaller package.

The LM1572 has programmable soft-start and frequency foldback to limit the inrush current, and a TTL compatible shutdown for easy sequencing. It draws 2.3mA of supply current in standby mode, and only 26μA in shutdown mode. The LM1572 is available in a TSSOP-16 package with an adjustable output or fixed outputs of 5V and 3.3V. The adjustable version can be set between 2.42V and 5V.

Features

- 500kHz clock allows small, surface mount components
- 150mΩ MOSFET switch
- Guaranteed load current of 1.5A
- Current mode control
- Programmable soft-start
- Internally set slope compensation
- TTL compatible shutdown
- Fixed 5V, 3.3V or adjustable output
- Low shutdown supply current of 26μA
- Cycle-by-cycle current limit
- Short-circuit protection and thermal protection
- TSSOP-16 package

Applications

- LCD Monitors and TVs
- Set-Top Boxes
- Cable Modems
- Down conversion from 12V in local/distributed systems

Typical Applications (Fixed/Adjustable Voltage Parts)

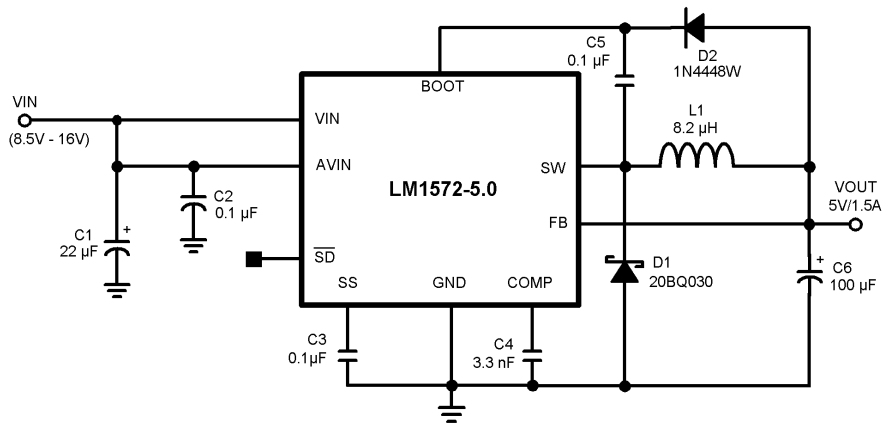

20033313

Absolute Maximum Ratings (Note 1)

If Military/Aerospace specified devices are required, please contact the National Semiconductor Sales Office/Distributors for availability and specifications.

ESD Tolerance (Note 2)	2kV
Input Voltage	17V
SD Pin Voltage	7V
FB Pin Voltage (All Options)	7V
Storage Temp. Range	-65°C to 150°C

Junction Temperature

150°C

Operating Ratings

Supply Voltage (V_{IN}) (Note 3)	8.5V to 16V
Junction Temperature Range	-40°C to +125°C
Package Thermal Resistance (TSSOP-16) (Note 4)	130°C/W

Electrical Characteristics

Unless otherwise specified, all limits are guaranteed for $T_A = 25^\circ\text{C}$, $V_{IN} = 15\text{V}$, $V_{COMP} = 1.5\text{V}$, $V_{SD} = 5\text{V}$, $I_{LOAD} = 0\text{A}$, unless otherwise noted. **Boldface** apply over the temperature extremes. ' V_{FB} low (high)' is 0.95 (1.05) times the nominal value at regulation.

Symbol	Parameter	Conditions	Min (Note 5)	Typ (Note 6)	Max (Note 5)	Units	
V_{FB_ADJ}	Voltage on Feedback pin (Adjustable version in regulation)		2.37 2.35	2.42	2.49 2.5	V	
V_{FB_5}	Voltage on Feedback pin (Fixed 5V version in regulation)		4.85 4.8	5.0	5.15 5.2	V	
$V_{FB_3.3}$	Voltage on Feedback pin (Fixed 3.3V version in regulation)		3.22 3.16	3.3	3.4 3.44	V	
$\Delta V_{FB}/V_{IN}$	Feedback Voltage Line Regulation	$V_{IN} = 8.5\text{V}$ to $V_{IN} = 16\text{V}$	-0.05	0	0.05	%/V	
I_{FB_REG}	Feedback Pin Bias Current (Adjustable Part)	V_{FB} at regulation	0	0.5	1.5	μA	
A_{V_ERROR}	Error Amplifier Voltage Gain (Note 7)			350			
$g_{m_{EA}}$	Error Amplifier Transconductance (Note 7)		1100 800	2000	2700 3200	μMho	
$g_{m_{COMP_SW}}$	Comp Pin to Switch Current Transconductance			2		A/V	
I_{EA_SOURCE}	Error Amplifier Source Current	V_{FB} low	50	200	300	μA	
I_{EA_SINK}	Error Amplifier Sink Current	V_{FB} high		2.4		mA	
V_{COMP_TH}	Comp Pin Switching Threshold	Duty Cycle = 0		0.9		V	
V_{COMP_LIM}	Comp Pin High Clamp			2		V	
I_{CLIM}	Switch Current Limit	$V_{BOOT} = V_{SW} + 5\text{V}$, Comp Open, V_{FB} low	$D \leq 0.5$	2.0	2.7	3.2	A
			$D = 0.8$	1.75	2.4	3	
R_{DS}	Switch ON Resistance	$I_{SW} = 1.5\text{A}$, $V_{BOOT} = V_{IN} + 5\text{V}$		0.15	0.4 0.5	Ω	
D_{MAX}	Maximum Duty Cycle (Note 8)	Comp Open, V_{FB} low	86	94		%	
f_{SW}	Switch Frequency	V_{FB} low, $V_{COMP} = 1\text{V}$, Full Temp. Range $-20^\circ\text{C} \leq T_J \leq 125^\circ\text{C}$		400	500	570	kHz
				440		560	
f_{REG}	Switch Frequency Line Regulation	$V_{IN} = 8.5\text{V}$ and $V_{IN} = 16\text{V}$, V_{FB} low, $V_{COMP} = 1\text{V}$		0.01		%/V	
$\Delta f_{FOLDBACK}$	Foldback Frequency shift (Adjustable part)	$V_{FB} = 0.8\text{V}$, $V_{COMP} = 1\text{V}$	20	90	160	kHz	

Electrical Characteristics (Continued)

Unless otherwise specified, all limits are guaranteed for $T_A = 25^\circ\text{C}$, $V_{IN} = 15\text{V}$, $V_{COMP} = 1.5\text{V}$, $V_{SD} = 5\text{V}$, $I_{LOAD} = 0\text{A}$, unless otherwise noted. **Boldface** apply over the temperature extremes. ' V_{FB} low (high)' is 0.95 (1.05) times the nominal value at regulation.

Symbol	Parameter	Conditions	Min (Note 5)	Typ (Note 6)	Max (Note 5)	Units
I_{SS}	Softstart Pin Current	$V_{SS} = 1\text{V}, V_{FB}=0\text{V}$	2.5	4.5	8	μA
I_{SD}	Shutdown Supply Current	$V_{SD} = 0\text{V}, V_{COMP} = 1\text{V}, V_{FB}$ low		26	52 75	μA
I_{STDBY}	Standby Supply Current	$V_{SD} = 1.5\text{V}$, Comp Open		2.3	4 4.3	mA
V_{UVLO}	Undervoltage Lockout Threshold	Comp Open, V_{FB} low	2.2	2.38	2.5	V
V_{SD}	Shutdown Threshold	Comp Open, $V_{COMP} = 1\text{V}$, V_{FB} low	0.75	1.0	1.28	V

Note 1: Absolute maximum ratings indicate limits beyond which damage to the device may occur. Operating ratings indicate conditions for which the device is intended to be functional, but specific performance is not guaranteed. For guaranteed specifications and the test conditions, see the Electrical Characteristics.

Note 2: This is for the human body model, which is a 100pF capacitor discharged through a 1.5k resistor into each pin.

Note 3: Minimum input voltage is defined as the voltage where internal bias lines are still regulated so that the reference voltage and oscillator remain constant. Actual minimum input voltage to maintain output in regulation depends on output voltage and load current. In particular, the required duty cycle must be less than the lowest possible upper duty cycle limit of the controller ($D_{MAX} = 0.86$). The maximum input voltage will also depend on output voltage and load current. In particular, the required duty cycle must be greater than the lowest possible duty cycle limit of the controller ($D_{MIN} = 0.15$), estimated from the typical minimum on-time, which is about 300ns.

Note 4: Junction to Ambient thermal resistance with the TSSOP-16 package soldered on a 1oz. printed circuit board with copper area of approximately 1in^2 .

Note 5: All limits guaranteed at room temperature (standard face type) and at **temperature extremes (bold face type)**. All room temperature limits are 100% production tested. All limits at **temperature extremes** are guaranteed via correlation using Statistical Quality Control (SQC) methods. All limits are used to calculate Average Outgoing Quality Level (AOQL).

Note 6: Typical numbers are at 25°C and represent the most likely norm.

Note 7: Transconductance and voltage gain refer to the internal amplifier, excluding any voltage divider as is present on the fixed voltage parts. To calculate the gain and transconductance for the fixed voltage parts, divide values shown in table by the ratio $V_{FB_5}/2.42 = 2.07$ for the 5V part and by $V_{FB_3.3}/2.42 = 1.36$ for the 3.3V part.

Note 8: To ensure stable operation, the maximum recommended operating duty cycle is 80%.

Physical Dimensions inches (millimeters) unless otherwise noted

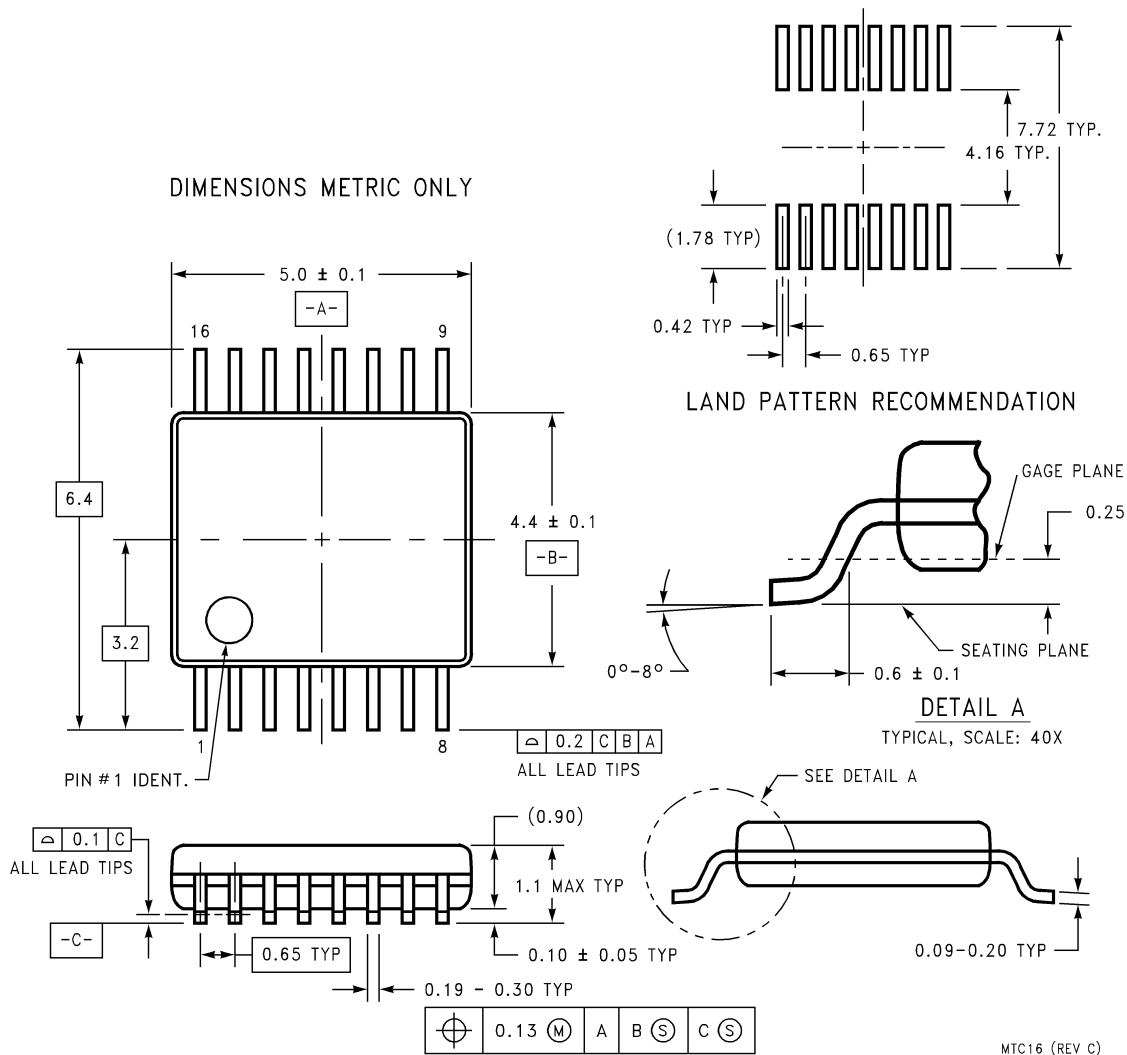

LIFE SUPPORT POLICY

NATIONAL'S PRODUCTS ARE NOT AUTHORIZED FOR USE AS CRITICAL COMPONENTS IN LIFE SUPPORT DEVICES OR SYSTEMS WITHOUT THE EXPRESS WRITTEN APPROVAL OF THE PRESIDENT AND GENERAL COUNSEL OF NATIONAL SEMICONDUCTOR CORPORATION. As used herein:

1. Life support devices or systems are devices or systems which, (a) are intended for surgical implant into the body, or (b) support or sustain life, and whose failure to perform when properly used in accordance with instructions for use provided in the labeling, can be reasonably expected to result in a significant injury to the user.
2. A critical component is any component of a life support device or system whose failure to perform can be reasonably expected to cause the failure of the life support device or system, or to affect its safety or effectiveness.

Looking for pricing, stock, or lifecycle information?

Click below to explore more details on WIN SOURCE:

 [View LM1572MTC-3.3 on WIN SOURCE](#)

 [Texas Instruments](#) Information

Optimize Your Supply Chain with WIN SOURCE Solutions

-  Global Sourcing Solution
-  Obsolete Management
-  Cost Control Management
-  Shortage Management
-  Alternative Solution
-  Excess Inventory Management