



**THE DATASHEET OF  
LM1770TMF/NOPB**



# LM1770 Low-Voltage SOT-23 Synchronous Buck Controller With No External Compensation

Check for Samples: [LM1770](#)

## FEATURES

- Input Voltage Range of 2.8V to 5.5V
- 0.8V Reference Voltage
- No Compensation Required
- Constant Frequency Across Input Range
- Low Quiescent Current of 400 $\mu$ A
- Internal Soft-start
- Short Circuit Protection
- 5-Pin SOT-23 Package

## APPLICATIONS

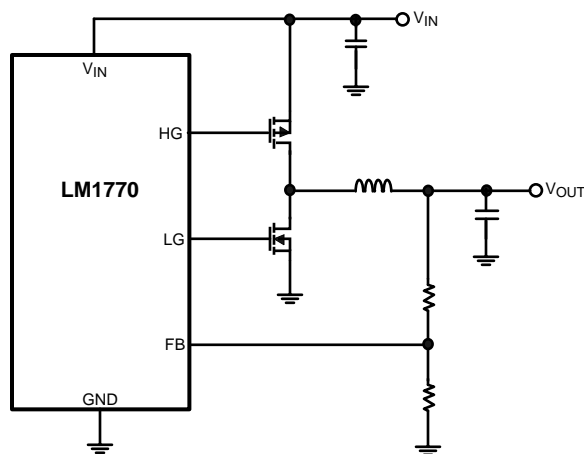
- Simple To Design, High Efficiency Step Down Switching Regulators
- Set-Top Boxes
- Cable Modems
- Printers
- Digital Video Recorders
- Servers

## DESCRIPTION

The LM1770 is an efficient synchronous buck switching controller in a tiny SOT-23 package. The constant on-time control scheme provides a simple design free of compensation components, allowing minimal component count and board space. It also incorporates a unique input feed-forward to maintain a constant frequency independent of the input voltage. The LM1770 is optimized for a low voltage input range of 2.8V to 5.5V and can provide an adjustable output as low as 0.8V. Driving an external high side PFET and low side NFET it can provide efficiencies as high as 95%.

Three versions of the LM1770 are available depending on the switching frequency desired for the application. Nominal switching frequencies are in the range of 100kHz to 1000kHz.

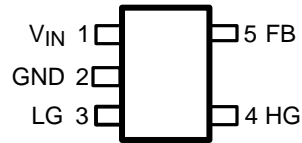
## Typical Application Circuit



Please be aware that an important notice concerning availability, standard warranty, and use in critical applications of Texas Instruments semiconductor products and disclaimers thereto appears at the end of this data sheet.

All trademarks are the property of their respective owners.

## Connection Diagram



**Figure 1. 5-Pin SOT-23 (Top View)**  
See DBV Package

## Pin Functions

**Table 1. Pin Descriptions**

Pin #	Name	Function
1	V <sub>IN</sub>	Input supply
2	GND	Ground
3	LG	NFET Gate Drive
4	HG	PFET Gate Drive
5	FB	Feedback Pin



These devices have limited built-in ESD protection. The leads should be shorted together or the device placed in conductive foam during storage or handling to prevent electrostatic damage to the MOS gates.

## Absolute Maximum Ratings <sup>(1) (2)</sup>

V <sub>IN</sub>	-0.3V to 6V
Storage Temperature Range	-65°C to 150°C
Junction Temperature	150°C
Lead Temperature (soldering, 10sec)	260°C
ESD Rating	2.5kV

- (1) [Absolute Maximum Ratings](#) indicate limits beyond which damage may occur to the device. [Operating Ratings](#) indicate conditions for which the device is intended to be functional, but do not ensure specific performance limits. For ensured specifications, see [Electrical Characteristics](#).
- (2) If Military/Aerospace specified devices are required, please contact the Texas Instruments Sales Office/ Distributors for availability and specifications.

## Operating Ratings <sup>(1)</sup>

V <sub>IN</sub> to GND	2.8V to 5.5V
Junction Temperature Range (T <sub>J</sub> )	-40°C to +125°C

- (1) [Absolute Maximum Ratings](#) indicate limits beyond which damage may occur to the device. [Operating Ratings](#) indicate conditions for which the device is intended to be functional, but do not ensure specific performance limits. For ensured specifications, see [Electrical Characteristics](#).

## Electrical Characteristics <sup>(1)</sup>

Specifications with standard typeface are for  $T_J = 25^\circ\text{C}$ , and those in **bold face type** apply over the full Junction Temperature Range ( $-40^\circ\text{C}$  to  $+125^\circ\text{C}$ ). Minimum and Maximum limits are specified through test, design or statistical correlation. Typical values represent the most likely parametric norm at  $T_J = 25^\circ\text{C}$  and are provided for reference purposes only. Unless otherwise specified  $V_{IN} = 3.3\text{V}$ .

Symbol	Parameter	Conditions	Min	Typ	Max	Unit
V <sub>FB</sub>	Feedback pin voltage	$V_{IN} = 3.3\text{V}$	<b>0.782</b>	0.80	<b>0.818</b>	V
		$V_{IN} = 5.0\text{V}$	<b>0.772</b>	0.79	<b>0.808</b>	
$\Delta V_{FB} / \Delta V_{IN}$	Line Regulation	$V_{IN} = 2.8\text{V}$ to $5.5\text{V}$		-5		mV/V
I <sub>Q</sub>	Operating Quiescent current	$V_{FB} = 0.9\text{V}$		400	<b>600</b>	μA
T <sub>ON</sub>	Switch On-Time	LM1770S - (500ns)	<b>0.4</b>	0.5	<b>0.6</b>	μs
		LM1770T - (1000ns)	<b>0.8</b>	1.0	<b>1.2</b>	
		LM1770U - (2000ns)	<b>1.6</b>	2.0	<b>2.4</b>	
T <sub>OFF_MIN</sub>	Minimum Off-Time	LM1770S - (500ns)		150	<b>250</b>	ns
		LM1770T - (1000ns)		135	<b>225</b>	
		LM1770U - (2000ns)		120	<b>220</b>	
T <sub>D</sub>	Gate Drive Dead-Time			70		ns
I <sub>FB</sub>	Feedback pin bias current	$V_{FB} = 0.9\text{V}$		50		nA
V <sub>UVLO</sub>	Under-voltage lock out	$V_{IN}$ Rising Edge		2.6	<b>2.8</b>	V
V <sub>UVLO_HYS</sub>	Under-voltage lock out hysteresis			30		mV
V <sub>SC_TH</sub>	Feedback pin Short Circuit Latch Threshold		<b>0.5</b>	0.55	<b>0.65</b>	V
R <sub>DS(ON) 1</sub>	HG FET driver pull-up On resistance	I <sub>HG</sub> = 20 mA		5		Ω
R <sub>DS(ON) 2</sub>	HG FET driver pull-down On resistance	I <sub>HG</sub> = 20 mA		9		Ω
R <sub>DS(ON) 3</sub>	LG FET driver pull-up On resistance	I <sub>LG</sub> = 20 mA		9		Ω
R <sub>DS(ON) 4</sub>	LG FET driver pull-down On resistance	I <sub>LG</sub> = 20 mA		5		Ω

- (1) [Absolute Maximum Ratings](#) indicate limits beyond which damage may occur to the device. [Operating Ratings](#) indicate conditions for which the device is intended to be functional, but do not ensure specific performance limits. For ensured specifications, see [Electrical Characteristics](#).

### Typical Performance Characteristics

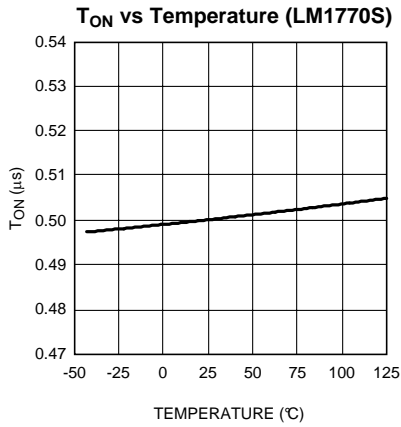


Figure 2.

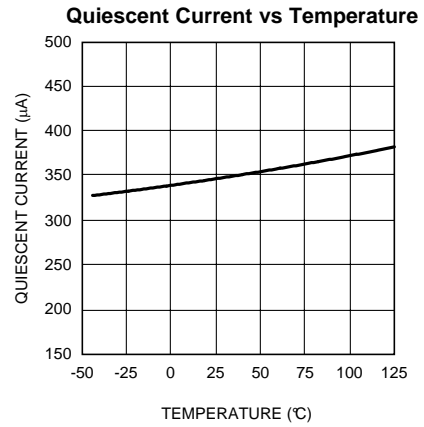


Figure 3.

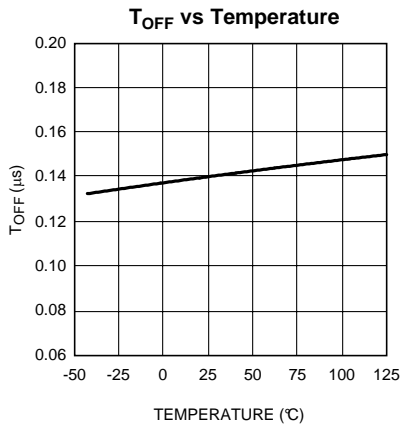


Figure 4.

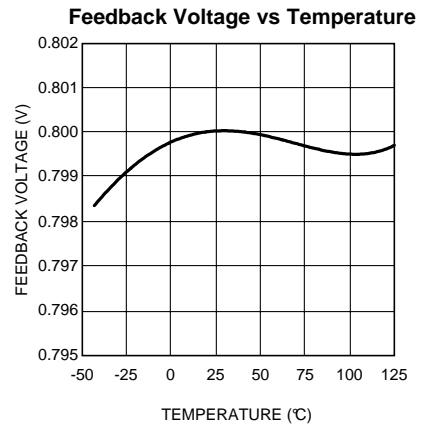


Figure 5.

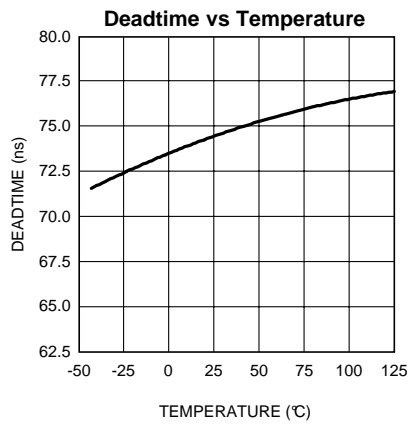


Figure 6.

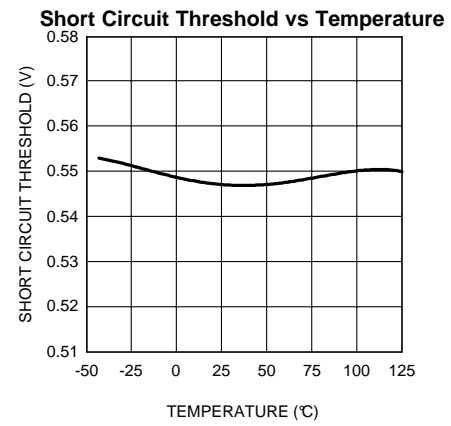


Figure 7.

Typical Performance Characteristics (continued)

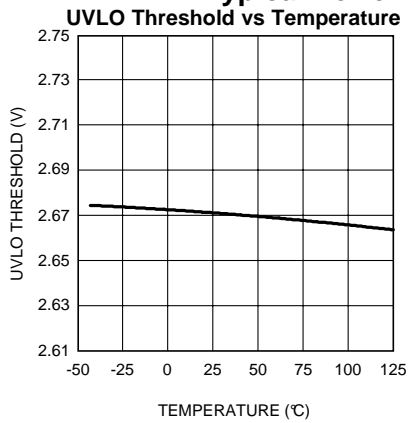


Figure 8.

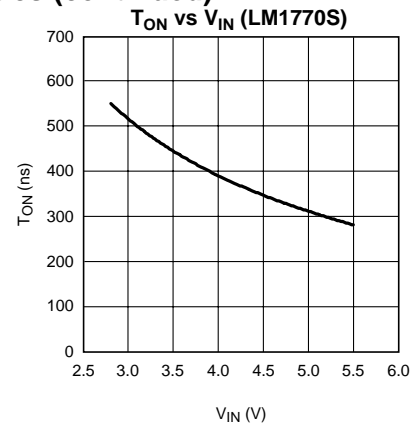


Figure 9.

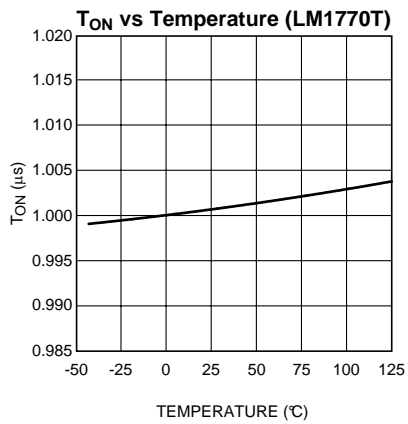


Figure 10.

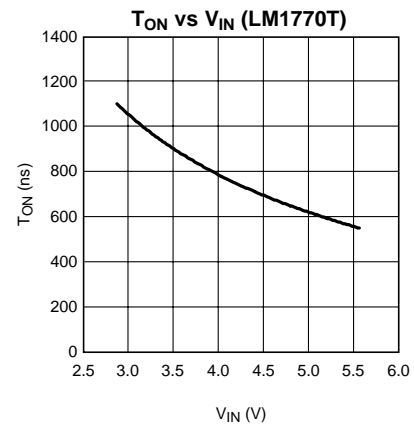


Figure 11.

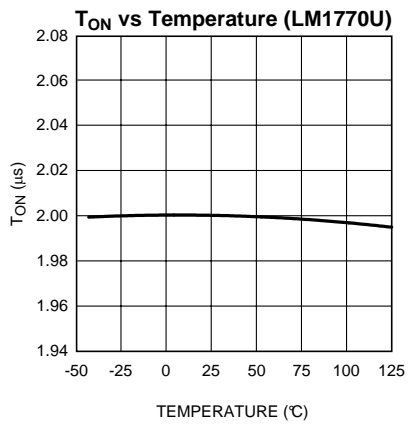


Figure 12.

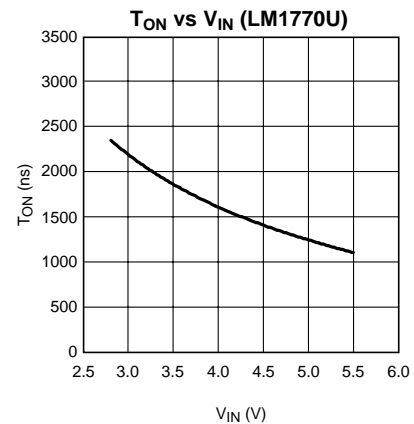
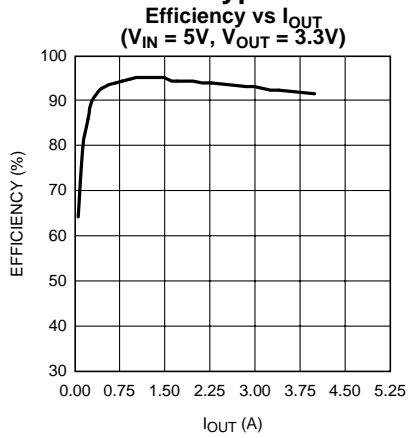
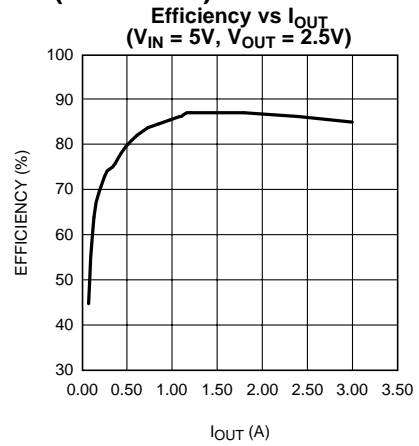


Figure 13.

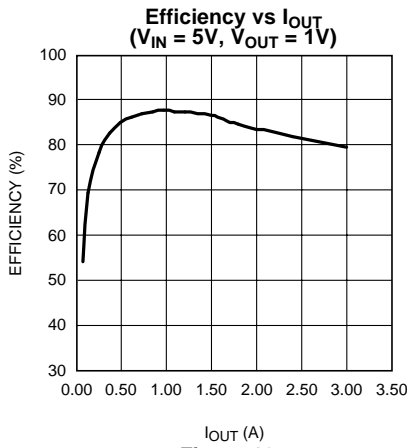
**Typical Performance Characteristics (continued)**



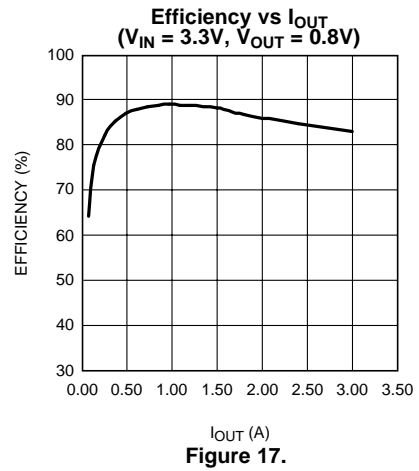
**Figure 14.**



**Figure 15.**

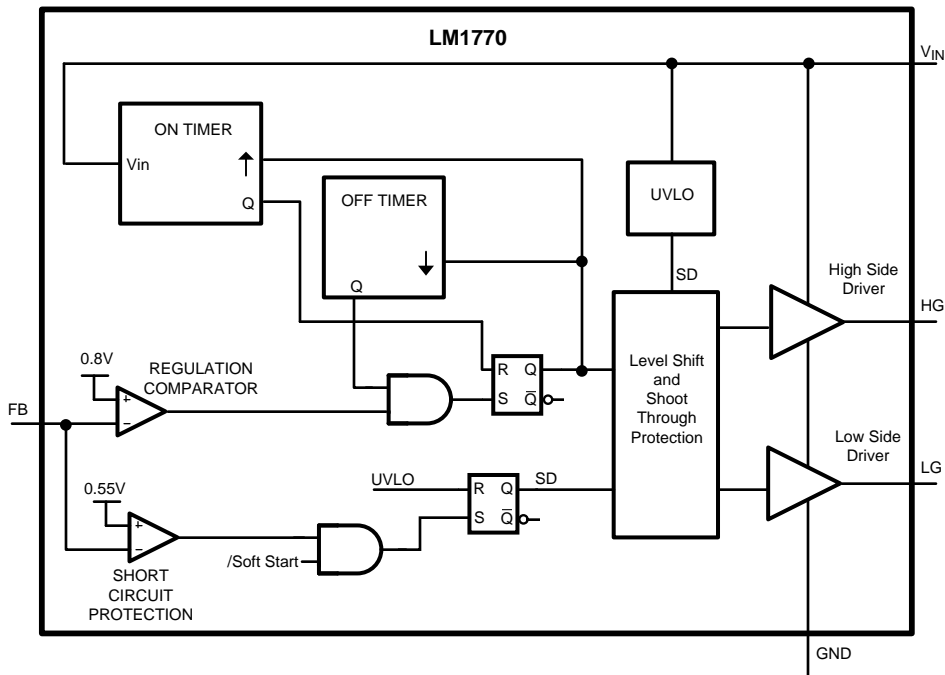


**Figure 16.**



**Figure 17.**

**BLOCK DIAGRAM**



## APPLICATION INFORMATION

### THEORY OF APPLICATION

The LM1770 synchronous buck switcher has a control scheme that is referred to as constant on-time control. This topology relies on a fixed switch on-time to regulate the output voltage. This on-time is internally set by EEPROM and is available with three different set-points to allow for different frequency options. The LM1770 automatically adjusts the on-time during operation inversely with the input voltage ( $V_{IN}$ ) to maintain a constant frequency. Therefore the switching frequency during continuous conduction mode is independent of the inductor and capacitor size unlike hysteretic switchers.

At the beginning of the cycle the LM1770 turns on the high side PFET for a fixed duration. This on-time is predetermined (internally set by EEPROM and adjusted by  $V_{IN}$ ) and the switch will not turn off until the timer has completed its period. The PFET will then turn off for a minimum pre-determined time period. This minimum  $T_{OFF}$  of 150ns is internally set and cannot be adjusted. This is to prevent false triggering from occurring on the comparator due to noise from the SW node transition. After the minimum  $T_{OFF}$  period has expired, the PFET will remain off until the comparator trip-point has been reached. Upon passing this trip-point (set at 0.8V at the feedback pin), the PFET will turn back on and the process will repeat, thus regulating the output.

The NFET control is complementary to the PFET control with the exception of a short dead-time to prevent shoot through from occurring.

### DEVICE OPERATION

#### Timing Opinion

Three versions of the LM1770 are available each with a predetermined  $T_{ON}$  set internally by EEPROM. This  $T_{ON}$  setting will determine the switching frequency for the application. Derivation and calculation of the switching frequency's dependence on  $V_{IN}$  and  $T_{ON}$  can be seen in the following section.

In a PWM buck switcher the following equations can be manipulated to obtain the switching frequency. [Equation 1](#) shows the standard duty-cycle equation given by the volts-seconds balance on the inductor with the following equations defining standard relationships:

$$D = \frac{V_{OUT}}{V_{IN}} \quad (1)$$

$$T_{ON} = D \times T_P \quad (2)$$

$$T_P = \frac{1}{f_{SW}} \quad (3)$$

Using this equation and solving for duty-cycle:

$$D = f_{SW} \times T_{ON} \quad (4)$$

Frequency can now be expressed as:

$$F = \frac{V_{OUT}}{V_{IN} \times T_{ON}} \quad (5)$$

Or simply written as:

$$f_{SW} = \frac{V_{OUT}}{\alpha} \quad (6)$$

where,

$$\alpha = V_{IN} \times T_{ON} \quad (7)$$

To maintain a set frequency in an application,  $\alpha$  is always held constant by varying  $T_{ON}$  inversely with  $V_{IN}$ . The three versions of the LM1770 are identified by the on times at a  $V_{IN}$  of 3.3V for consistency. For clarification see [Table 2](#):

**Table 2. LM1770 "ON" Times Identification**

Product ID	$T_{ON}$ @ 3.3V	$\alpha$ (V $\mu$ s)
LM1770S	0.5 $\mu$ s	1.65
LM1770T	1.0 $\mu$ s	3.3

**Table 2. LM1770 "ON" Times Identification (continued)**

Product ID	$T_{ON}$ @ 3.3V	$\alpha$ (V $\mu$ s)
LM1770U	2.0 $\mu$ s	6.6

The variation of  $T_{ON}$  versus  $V_{IN}$  can also be expressed graphically. These graphs can be found in the [Typical Performance Characteristics](#) section.

With  $\alpha$  being a constant regardless of the version of the LM1770 used, [Equation 6](#) shows that the only dependent variable remaining is  $V_{OUT}$ . Since  $V_{OUT}$  will be a constant in any application, the frequency will also remain constant. The switching frequency at which the application runs depends upon the  $V_{OUT}$  desired and the LM1770 version chosen. For any  $V_{OUT}$ , three frequency options (LM1770 versions) can be selected. This can be seen in [Table 3](#). The recommended frequency range of operation is 100kHz to 1000kHz.

**Table 3. LM1770  $V_{OUT}$  Frequency Option**

VOUT	Timing Options		
	500ns	1000ns	2000ns
0.8	485	242	121
1	606	303	152
1.2	727	364	182
1.5	909	455	227
1.8	1091	545	273
2.5	1515	758	379
3.3	2000	1000	500

## SHORT-CIRCUIT PROTECTION

The LM1770 has an internal short circuit comparator that constantly monitors the feedback node (except during soft-start). If the feedback voltage drops below 0.55V (equivalent to the output voltage dropping below 68% of nominal), the comparator will trip causing the part to latch off. The LM1770 will not resume switching until the input voltage is taken below the UVLO threshold and then brought back into its normal operating range. The purpose of this function is to prevent a severe short circuit from causing damage to the application. Due to the fast transient response of the LM1770 a severe short on the output causing the feedback to drop would only occur if the load applied had an effective resistance that approaches the PMOS  $R_{DS(ON)}$ .

## SOFT-START

To limit in-rush current and allow for a controlled startup the LM1770 incorporates an internal soft-start scheme. Every time the input voltage rises through the UVLO threshold the LM1770 goes through an adaptive soft-start that limits the on-time and expands the minimum off-time. In addition the part will only activate the PMOS allowing a discontinuous mode of operation enabling a pre-biased startup. The time spent in soft-start will depend on the load applied to the output, but is usually close to a set time that is dependent on the timing option. The approximate soft-start time can be seen in [Table 4](#) for each timing option.

**Table 4. Soft-Start Time Approximations**

Product ID	Timing	$T_{SS}$
LM1770S	0.5 $\mu$ s	1ms
LM1770T	1.0 $\mu$ s	1.2ms
LM1770U	2.0 $\mu$ s	1.8ms

It should be noted that as soon as soft-start terminates the short-circuit protection is enabled. This means that if the output voltage does not reach at least 68% of its final value the part will latch off. Therefore, if the input supply is extremely slow rising such that at the end of soft-start the input voltage is still near the UVLO threshold, a timing option should be chosen to ensure that maximum duty-cycle permits the output to meet the minimum condition. As a general recommendation it is advisable to use the 2000ns option (LM1770U) in conditions where the output voltage is 2.5V or greater to avoid false latch offs when there is concern regarding the input supply slew rate.

## JITTER

The LM1770 utilizes a constant on-time control scheme that relies on the output voltage ripple to provide a consistent switching frequency. Under certain conditions, excessive noise can couple onto the feedback pin causing the switch node to appear to have a slight amount of jitter. This is not indicative of an unstable design. The output voltage will still regulate to the exact same value. Careful component selection and layout should minimize any external influence.

In addition to any external noise that can add to the jitter seen on the switch node, the LM1770 will always have a slight amount of switch jitter. This is because the LM1770 makes a small alteration in the reference voltage every 128 cycles to improve its accuracy and long term performance. This has the effect of causing a change in the switching frequency at that instant. When viewed on an oscilloscope this can be seen as a jitter in the switch node. The change in feedback voltage or output voltage, however, is almost indistinguishable.

## DESIGN GUIDE

The following section walks the designer through the steps necessary to select the external components to build a fully functional power supply. As with any DC-DC converter numerous trade-offs are possible to optimize the design for efficiency, size or performance. These will be taken into account and highlighted throughout this discussion.

The first equation to calculate for any buck converter is duty-cycle. Ignoring conduction losses associated with the FETs and parasitic resistances it can be approximated by:

$$D = \frac{V_{OUT}}{V_{IN}} \quad (8)$$

A more accurate calculation for duty-cycle can be used that takes into account the voltage drops across the FETs. Equation 9 can be used to determine the slight load dependency on switch frequency if needed. Otherwise the simplified equation works well for component calculation.

$$D = \frac{V_{OUT} + V_{DS\_NMOS}}{V_{IN} + V_{DS\_NMOS} + V_{DS\_PMOS}} \quad (9)$$

### FREQUENCY SELECTION

The LM1770 is available with three preset timing options that select the on-time and hence determine the switching frequency of the application. Increasing the switching frequency has the effect of reducing the inductor size needed for the application while requiring a slight trade-off in efficiency. Table 5 shows the same frequency table as shown previously in Table 3, with the exception that the recommended timing option for each  $V_{OUT}$  is highlighted. It is not recommended to use a high switching frequency with  $V_{OUT}$  equal to or greater than 2.5V due to the maximum duty-cycle limitations of the device coupled with the internal startup.

**Table 5. LM1770 Recommended  $V_{OUT}$  Frequency Option**

$V_{OUT}$	Timing Options		
	500ns	1000ns	2000ns
0.8	485	242	-
1	606	303	-
1.2	727	364	-
1.5	909	455	227
1.8	-	545	273
2.5	-	-	379
3.3	-	-	500

### INDUCTOR SELECTION

The inductor selection is an iterative process likely requiring several passes before settling on a final value. The reason for this is because it influences the amount of ripple seen at the output, a critical component to ensure general stability of an adaptive on-time circuit. For the first pass at inductor selection the value can be obtained by targeting a maximum peak-to-peak ripple current equal to 30% of the maximum load current. The inductor current ripple ( $\Delta I_L$ ) can be calculated by:

$$\Delta I_L = \frac{(V_{IN} - V_{OUT}) \times D}{L \times f_{SW}} \quad (10)$$

Therefore, L can be initially set to the following by applying the 30% rule:

$$L = \frac{(V_{IN} - V_{OUT}) \times D}{0.3 \times f_{SW} \times I_{OUT}} \quad (11)$$

The other features of the inductor that can be selected besides inductance value are saturation current and core material. Because the LM1770 does not have a current limit, it is recommended to have a saturation current higher than the maximum output current to handle any ripple or momentary over-current events. The core material also influences the saturation characteristics as ferrite materials have a hard saturation curve and care should be taken such that they never saturate during normal use. A shielded inductor or low profile unshielded inductor is recommended to reduce EMI. This also helps prevent any spurious noise from picking up on the feedback node resulting in unexpected tripping of the feedback comparator.

## OUTPUT CAPACITOR

One of the most important components to select with the LM1770 is the output capacitor. This is because its size and ESR have a direct effect on the stability of the loop. A constant on-time control scheme works by sensing the output voltage ripple and switching the FETs appropriately. The output voltage ripple on a buck converter can be approximated by stating that the AC inductor ripple flows entirely into the output capacitor and is created by the ESR of the capacitor. This can be expressed in the following equation:

$$\Delta V_{OUT} = \Delta I_L \times R_{ESR} \quad (12)$$

To ensure stability, two constraints need to be met. The first is that there is sufficient ESR to create enough voltage ripple at the feedback pin. The recommendation is to have at least 10mV of ripple seen at the feedback pin. This can be calculated by multiplying the output voltage ripple by the gain seen through the feedback resistors. This gain, H, can be calculated below:

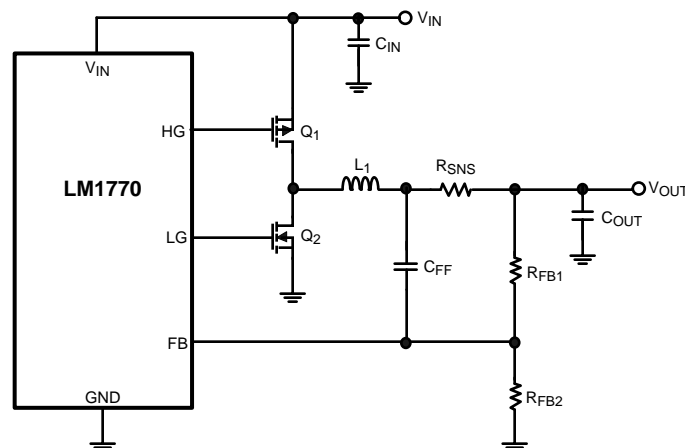
$$H = \frac{V_{FB}}{V_{OUT}} = \frac{0.8V}{V_{OUT}} \quad (13)$$

If the output voltage is fairly high, causing significant attenuation through the feedback resistors, a feed-forward capacitor can be used. This is actually recommended for most circuits as it improves performance. See the [Feed-Forward Capacitor](#) section for more details.

The second criteria is to ensure that there is sufficient ripple at the output that is in-phase with the switch. The problem exists that there is actually ripple caused by the capacitor charging and discharging, not only the ESR ripple. Since these are effectively out of phase, problems can exist. To avoid this issue it is recommended that the ratio of the two ripples ( $\beta$ ) is always greater than 5. To calculate the minimum ESR value needed, the following equation can be used.

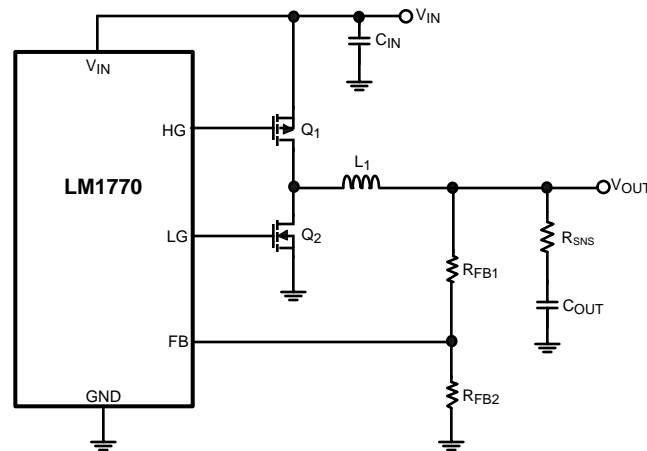
$$R_{ESR} \geq \frac{\beta \times t_p}{8 \times C} \quad (14)$$

In general the best capacitors to use are chemistries that have a known and consistent ESR across the entire operating temperature range. Tantalum capacitors or similar chemistries such as Niobium Oxide perform well along with certain families of Aluminum Electrolytics. Small value POSCAPs and SP CAPs also work as they have sufficient ESR. When used in conjunction with a low value inductor it is possible to have an extremely stable design. The only capacitors that require modification to the circuit are ceramic capacitors. Ceramic capacitors cause problems meeting both criteria because they have low ESR and low capacitance. Therefore, if they are to be used, an external ESR resistor ( $R_{SNS}$ ) should be added. This can be seen below in the following circuit.



This circuit uses an additional resistor in series with the inductor to add ripple at the output. It is placed in this location and used in combination with the feed-forward capacitor ( $C_{FF}$ ) to provide ripple to the feedback pin, without adding ripple or a DC offset to the output. The benefit of using a ceramic capacitor is still obtained with this technique. Because the addition of the resistor results in power loss, this circuit implementation is only recommended for low currents (2A and below). The power loss and rating of the resistor should be taken into account when selecting this component.

This circuit implementation utilizing the feed-forward capacitor begins to experience limitations when the output voltage is small. Previously the circuit relied on the  $C_{FF}$  for all the ripple at the feedback node by assuming that the resistor divider was negligible. As  $V_{OUT}$  decreases this can not be assumed. The resistor divider contributes a larger amount of ripple which is problematic as it is also out of phase. Therefore the resistor location should be changed to be in series with the output capacitor. This can be viewed as adding an effective ESR to the output capacitor.



## FEED-FORWARD CAPACITOR

The feed-forward capacitor is used across the top feedback resistor to provide a lower impedance path for the high frequency ripple without degrading the DC accuracy. Typically the value for this capacitor should be small enough to prevent load transient errors because of the discharging time, but large enough to prevent attenuation of the ripple voltage. In general a small ceramic capacitor in the range of 1nF to 10nF is sufficient.

If  $C_{FF}$  is used then it can be assumed that the ripple voltage seen at the feedback pin is the same as the ripple voltage at the output. The attenuation factor  $H$  no longer needs to be used. However, in these conditions, it is recommended to have a minimum of 20mV ripple at the feedback pin. The use of a  $C_{FF}$  capacitor is recommended as it improves the regulation and stability of the design. However, its benefit is diminished as  $V_{OUT}$  starts approaching  $V_{REF}$ , therefore it is not needed in this situation.

## INPUT CAPACITOR

The dominating factor that usually sets an input capacitors' size is the current handling ability. This is usually determined by the package size and ESR of the capacitor. If these two criteria are met then there usually should be enough capacitance to prevent impedance interactions with the source. In general it is recommended to use a ceramic capacitor for the input as they provide a low impedance and small footprint. One important note is to use a good dielectric for the ceramic capacitor such as X5R or X7R. These provide better over temperature performance and also minimize the DC voltage derating that occurs on Y5V capacitors. To calculate the input capacitor RMS current, the equation below can be used:

$$I_{CIN\_RMS} = I_{OUT} \sqrt{D \left( 1 - D + \frac{\Delta I_L^2}{12 \times I_{OUT}^2} \right)} \quad (15)$$

which can be approximated by,

$$I_{CIN\_RMS} = I_{OUT} \times \sqrt{D(1 - D)} \quad (16)$$

## MOSFET Selection

The two FETs used in the LM1770 requires attention to selection of parameters to ensure optimal performance of the power supply. The high side FET should be a PFET and the low side an NFET. These can be integrated in one package or as two separate packages. The criteria that matter in selection are listed below:

### VDS VOLTAGE RATING

The first selection criteria is to select FETs that have sufficient  $V_{DS}$  voltage ratings to handle the maximum voltage seen at the input plus any transient spikes that can occur from parasitic ringing. In general most FETs available for this application will have ratings from 8V to 20V. If a larger voltage rating is used then the performance will most likely be degraded because of higher gate capacitance.

### RDSON

The  $R_{DS(ON)}$  specification is important as it determines several attributes of the FET and the overall power supply. The first is that it sets the maximum current of the FET for a given package. A lower  $R_{DS(ON)}$  will permit a higher allowable current and reduce conduction losses, however, it will increase the gate capacitance and the switching losses.

### GATE DRIVE

The next step is to ensure that the FETs are capable of switching at the low  $V_{in}$  supplies used by the LM1770. The FET should have the  $R_{dson}$  specified at either 1.8V or 2.5V to ensure that it can switch effectively as soon as the LM1770 starts up.

### GATE CHARGE

Because the LM1770 utilizes a fixed dead-time scheme to prevent cross conduction, the FET transitions must occur in this time. The rise and fall time of the FETs gate can be influenced by several factors including the gate capacitance. Therefore the total gate charge of both FETs should be limited to less than 20nC at 4.5V  $V_{GS}$ . The lower the number the faster the FETs should switch and the better the efficiency.

### RISE / FALL TIMES

A better indication of the actual switching times of the FETs can be found in their [Electrical Characteristics](#) table. The rise and fall time should be specified and selected to be at a minimum. This helps improve efficiency and ensuring that shoot through does not occur.

### GATE CHARGE RATIO

Another consideration in selecting the FETs is to pay attention to the  $Q_{gd} / Q_{gs}$  ratio. The reason for this is that proper selection can prevent spurious turn on. If we look at the NFET for example, when the FET is turning off, the gate signal will pull to ground. Conversely the PFET will be turning on, causing the SW node to rise towards  $V_{IN}$ . The gate to drain capacitance of the NFET couples the SW node to the gate and will cause it to rise. If this voltage is excessive, then it could weakly turn on the low side FET causing an efficiency loss. However, this coupling is mitigated by having a large gate to source capacitance of the FET, which helps to hold the gate voltage down. Ideally, a very low  $Q_{gd} / Q_{gs}$  would be ideal, but in practice it is common to find the number around 1. As a general rule, the lower the ratio, the better.

If the above selection criteria have been met it is useful to generate a figure of merit to allow comparison between the FETs. One such method is to multiply the  $R_{DS(ON)}$  of the FET by the total gate charge. This allows an easy comparison of the different FETs available. Once again, the lower the product, the better.

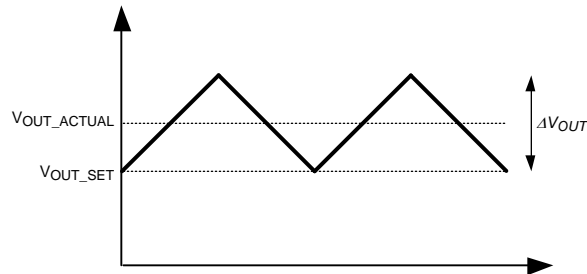
### FEEDBACK RESISTORS

The feedback resistors are used to scale the output voltage to the internal reference value such that the loop can be regulated. The feedback resistors should not be made arbitrarily large as this creates a high impedance node at the feedback pin that is more susceptible to noise. A combined value of 50k $\Omega$  for the two resistors is adequate. To calculate the resistor values use the equation below. Typically the low side resistor is initially set to a pre-determined value such as 10 k $\Omega$ .

$$R_{FB1} = R_{FB2} \left( \frac{V_{OUT}}{V_{FB}} - 1 \right) \quad (17)$$

$V_{FB}$  is the internal reference voltage that can be found in the [Electrical Characteristics](#) table or approximated by 0.8V.

The output voltage value can be set in a precise manner by taking into account the fact that the reference voltage is regulating the bottom of the output ripple as opposed to the average value. This relationship is shown in the figure below.



It can be seen that the average output voltage ( $V_{OUT\_ACTUAL}$ ) is higher than the output voltage ( $V_{OUT\_SET}$ ) that was calculated by the earlier equation by exactly half the output voltage ripple. The output voltage that is targeted for regulation may then be appended according to the voltage ripple. This can be seen below:

$$V_{OUT\_ACTUAL} = V_{OUT\_SET} + \frac{1}{2}\Delta V_{OUT} = V_{OUT\_SET} + \frac{1}{2}\Delta I_L \times R_{ESR} \quad (18)$$

### Efficiency Calculations

One of the most important parameters to calculate during the design stage is the expected efficiency of the system. This can help determine optimal FET selection and can be used to calculate expected temperature rise of the individual components. The individual losses of each component are broken down and the equations are listed below:

#### QUIESCENT CURRENT

The quiescent current consumed by the LM1770 is one of the major sources of loss within the controller. However, from a system standpoint this is usually less than 0.5% of the overall efficiency. Therefore, it could easily be omitted but is shown for completeness:

$$P_{IQ} = V_{IN} \times I_Q \quad (19)$$

#### CONDUCTION LOSS

There are three losses associated with the external FETs. From the DC standpoint there is the I-squared R loss, caused by the on resistance of the FET. This can be modeled for the PMOS by:

$$P_{P\_COND} = D \times R_{DSON\_PMOS} \times I_{OUT}^2 \quad (20)$$

and the NMOS by:

$$P_{N\_COND} = (1 - D) \times R_{DSON\_NMOS} \times I_{OUT}^2 \quad (21)$$

#### SWITCHING LOSS

The next loss is the switching loss that is caused by the need to charge and discharge the gate capacitance of the FETs every cycle. This can be approximated by:

$$P_{P\_SWITCH} = V_{IN} \times Q_{g\_PMOS} \times f_{SW} \quad (22)$$

for the PMOS, and the same approach can be adapted for the NMOS:

$$P_{N\_SWITCH} = V_{IN} \times Q_{g\_NMOS} \times f_{SW} \quad (23)$$

## TRANSITIONAL LOSS

The last FET power loss is the transitional loss. This is caused by switching the PMOS while it is conducting current. This approach only models the PMOS transition, the NMOS loss is considered negligible because it has minimal drain to source voltage when it switches due to the conduction of the body diode. Therefore the transitional loss of the PMOS can be modeled by:

$$P_{P\_TRANSITIONAL} = 0.5 \times V_{IN} \times I_{OUT} \times f_{SW} \times (t_r + t_f) \quad (24)$$

$t_r$  and  $t_f$  are the rise and fall times of the FET and can be found in their corresponding datasheet. Typically these numbers are simulated using a  $6\Omega$  drive, which corresponds well to the LM1770. Given this, no adjustment is needed.

## DCR LOSS

The last source of power loss in the system that needs to be calculated is the loss associated with the inductor resistance (DCR) which can be calculated by

$$P_{DCR} = R_{DCR} \times I_{OUT}^2 \quad (25)$$

## EFFICIENCY

The efficiency,  $\eta$ , can then be calculated by summing all the power losses and then using the equation below:

$$\eta = \frac{P_{OUT}}{P_{OUT} + P_{LOSSES}} \quad (26)$$

## Thermals

By breaking down the individual power loss in each component it makes it easy to determine the temperature rise of each component. Generally the expected temperature rise of the LM1770 is extremely low as it is not in the power path. Therefore the only two items of concern are the PMOS and the NMOS. The power loss in the PMOS is the sum of the conduction loss and transitional loss, while the NMOS only has conduction loss. It is assumed that any loss associated with the body diode conduction during the dead-time is negligible.

For completeness of design it is important to watch out for the temperature rise of the inductor. Assuming the inductor is kept out of saturation the predominant loss will be the DC copper resistance. At higher frequencies, depending on the core material, the core loss could approach or exceed the DCR losses. Consult with the inductor manufacturer for appropriate temp curves based on current.

## Layout

The LM1770, like all switching regulators, requires careful attention to layout to ensure optimal performance. The following steps should be taken to aid in the layout. For more information refer to Application Note AN-1299 [SNVA074](#).

1. Ensure that the ground connections of the input capacitor, output capacitor and NMOS are as close as possible. Ideally these should all be grounded together in close proximity on the component side of the board.
2. Keep the switch node small to minimize EMI without degrading thermal cooling of the FETs.
3. Locate the feedback resistors close to the IC and keep the feedback trace as short as possible. Do not run any feedback traces near the switch node.
4. Keep the gate traces short and keep them away from the switch node as much as possible.
5. If a small bypass capacitor is used on  $V_{IN}$  ( $0.1\mu\text{F}$ ) place it as close to the pin, with the ground connection as close to the chip ground as possible.

---

**REVISION HISTORY**

<b>Changes from Revision B (April 2013) to Revision C</b>	<b>Page</b>
<hr/> <ul style="list-style-type: none"><li>• Changed layout of National Data Sheet to TI format .....</li></ul>	<hr/> <a href="#">16</a>

**PACKAGING INFORMATION**

Orderable Device	Status (1)	Package Type	Package Drawing	Pins	Package Qty	Eco Plan (2)	Lead/Ball Finish (6)	MSL Peak Temp (3)	Op Temp (°C)	Device Marking (4/5)	Samples
LM1770SMF/NOPB	ACTIVE	SOT-23	DBV	5	1000	Green (RoHS & no Sb/Br)	CU SN	Level-1-260C-UNLIM	-40 to 125	SKJB	<a href="#">Samples</a>
LM1770TMF/NOPB	ACTIVE	SOT-23	DBV	5	1000	Green (RoHS & no Sb/Br)	CU SN	Level-1-260C-UNLIM	-40 to 125	SKKB	<a href="#">Samples</a>
LM1770TMFX/NOPB	ACTIVE	SOT-23	DBV	5	3000	Green (RoHS & no Sb/Br)	CU SN	Level-1-260C-UNLIM	-40 to 125	SKKB	<a href="#">Samples</a>
LM1770UMF/NOPB	ACTIVE	SOT-23	DBV	5	1000	Green (RoHS & no Sb/Br)	CU SN	Level-1-260C-UNLIM	-40 to 125	SKLB	<a href="#">Samples</a>
LM1770UMFX/NOPB	ACTIVE	SOT-23	DBV	5	3000	Green (RoHS & no Sb/Br)	CU SN	Level-1-260C-UNLIM	-40 to 125	SKLB	<a href="#">Samples</a>

(1) The marketing status values are defined as follows:

**ACTIVE:** Product device recommended for new designs.

**LIFEBUY:** TI has announced that the device will be discontinued, and a lifetime-buy period is in effect.

**NRND:** Not recommended for new designs. Device is in production to support existing customers, but TI does not recommend using this part in a new design.

**PREVIEW:** Device has been announced but is not in production. Samples may or may not be available.

**OBSOLETE:** TI has discontinued the production of the device.

(2) Eco Plan - The planned eco-friendly classification: Pb-Free (RoHS), Pb-Free (RoHS Exempt), or Green (RoHS & no Sb/Br) - please check <http://www.ti.com/productcontent> for the latest availability information and additional product content details.

**TBD:** The Pb-Free/Green conversion plan has not been defined.

**Pb-Free (RoHS):** TI's terms "Lead-Free" or "Pb-Free" mean semiconductor products that are compatible with the current RoHS requirements for all 6 substances, including the requirement that lead not exceed 0.1% by weight in homogeneous materials. Where designed to be soldered at high temperatures, TI Pb-Free products are suitable for use in specified lead-free processes.

**Pb-Free (RoHS Exempt):** This component has a RoHS exemption for either 1) lead-based flip-chip solder bumps used between the die and package, or 2) lead-based die adhesive used between the die and leadframe. The component is otherwise considered Pb-Free (RoHS compatible) as defined above.

**Green (RoHS & no Sb/Br):** TI defines "Green" to mean Pb-Free (RoHS compatible), and free of Bromine (Br) and Antimony (Sb) based flame retardants (Br or Sb do not exceed 0.1% by weight in homogeneous material)

(3) MSL, Peak Temp. - The Moisture Sensitivity Level rating according to the JEDEC industry standard classifications, and peak solder temperature.

(4) There may be additional marking, which relates to the logo, the lot trace code information, or the environmental category on the device.

(5) Multiple Device Markings will be inside parentheses. Only one Device Marking contained in parentheses and separated by a "~" will appear on a device. If a line is indented then it is a continuation of the previous line and the two combined represent the entire Device Marking for that device.

<sup>(6)</sup> Lead/Ball Finish - Orderable Devices may have multiple material finish options. Finish options are separated by a vertical ruled line. Lead/Ball Finish values may wrap to two lines if the finish value exceeds the maximum column width.

**Important Information and Disclaimer:**The information provided on this page represents TI's knowledge and belief as of the date that it is provided. TI bases its knowledge and belief on information provided by third parties, and makes no representation or warranty as to the accuracy of such information. Efforts are underway to better integrate information from third parties. TI has taken and continues to take reasonable steps to provide representative and accurate information but may not have conducted destructive testing or chemical analysis on incoming materials and chemicals. TI and TI suppliers consider certain information to be proprietary, and thus CAS numbers and other limited information may not be available for release.

In no event shall TI's liability arising out of such information exceed the total purchase price of the TI part(s) at issue in this document sold by TI to Customer on an annual basis.

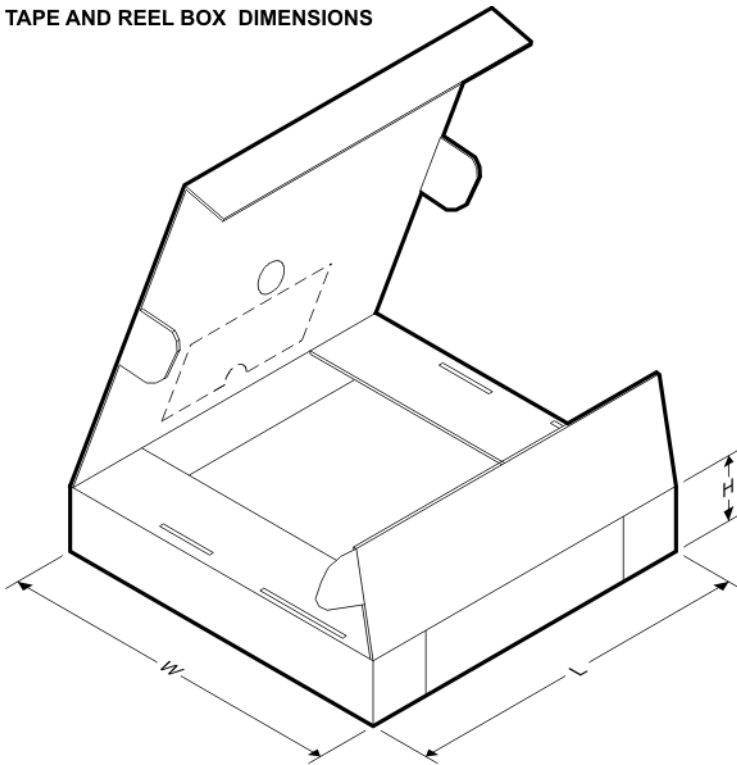
**TAPE AND REEL INFORMATION**

**QUADRANT ASSIGNMENTS FOR PIN 1 ORIENTATION IN TAPE**


\*All dimensions are nominal

Device	Package Type	Package Drawing	Pins	SPQ	Reel Diameter (mm)	Reel Width W1 (mm)	A0 (mm)	B0 (mm)	K0 (mm)	P1 (mm)	W (mm)	Pin1 Quadrant
LM1770SMF/NOPB	SOT-23	DBV	5	1000	178.0	8.4	3.2	3.2	1.4	4.0	8.0	Q3
LM1770TMF/NOPB	SOT-23	DBV	5	1000	178.0	8.4	3.2	3.2	1.4	4.0	8.0	Q3
LM1770TMFX/NOPB	SOT-23	DBV	5	3000	178.0	8.4	3.2	3.2	1.4	4.0	8.0	Q3
LM1770UMF/NOPB	SOT-23	DBV	5	1000	178.0	8.4	3.2	3.2	1.4	4.0	8.0	Q3
LM1770UMFX/NOPB	SOT-23	DBV	5	3000	178.0	8.4	3.2	3.2	1.4	4.0	8.0	Q3

**TAPE AND REEL BOX DIMENSIONS**



\*All dimensions are nominal

Device	Package Type	Package Drawing	Pins	SPQ	Length (mm)	Width (mm)	Height (mm)
LM1770SMF/NOPB	SOT-23	DBV	5	1000	210.0	185.0	35.0
LM1770TMF/NOPB	SOT-23	DBV	5	1000	210.0	185.0	35.0
LM1770TMFX/NOPB	SOT-23	DBV	5	3000	210.0	185.0	35.0
LM1770UMF/NOPB	SOT-23	DBV	5	1000	210.0	185.0	35.0
LM1770UMFX/NOPB	SOT-23	DBV	5	3000	210.0	185.0	35.0



# EXAMPLE BOARD LAYOUT

DBV0005A

SOT-23 - 1.45 mm max height

SMALL OUTLINE TRANSISTOR



LAND PATTERN EXAMPLE  
EXPOSED METAL SHOWN  
SCALE:15X



SOLDER MASK DETAILS

4214839/D 11/2018

NOTES: (continued)

- 5. Publication IPC-7351 may have alternate designs.
- 6. Solder mask tolerances between and around signal pads can vary based on board fabrication site.

# EXAMPLE STENCIL DESIGN

DBV0005A

SOT-23 - 1.45 mm max height

SMALL OUTLINE TRANSISTOR



SOLDER PASTE EXAMPLE  
BASED ON 0.125 mm THICK STENCIL  
SCALE:15X

4214839/D 11/2018

NOTES: (continued)

7. Laser cutting apertures with trapezoidal walls and rounded corners may offer better paste release. IPC-7525 may have alternate design recommendations.
8. Board assembly site may have different recommendations for stencil design.

## IMPORTANT NOTICE AND DISCLAIMER

TI PROVIDES TECHNICAL AND RELIABILITY DATA (INCLUDING DATASHEETS), DESIGN RESOURCES (INCLUDING REFERENCE DESIGNS), APPLICATION OR OTHER DESIGN ADVICE, WEB TOOLS, SAFETY INFORMATION, AND OTHER RESOURCES "AS IS" AND WITH ALL FAULTS, AND DISCLAIMS ALL WARRANTIES, EXPRESS AND IMPLIED, INCLUDING WITHOUT LIMITATION ANY IMPLIED WARRANTIES OF MERCHANTABILITY, FITNESS FOR A PARTICULAR PURPOSE OR NON-INFRINGEMENT OF THIRD PARTY INTELLECTUAL PROPERTY RIGHTS.

These resources are intended for skilled developers designing with TI products. You are solely responsible for (1) selecting the appropriate TI products for your application, (2) designing, validating and testing your application, and (3) ensuring your application meets applicable standards, and any other safety, security, or other requirements. These resources are subject to change without notice. TI grants you permission to use these resources only for development of an application that uses the TI products described in the resource. Other reproduction and display of these resources is prohibited. No license is granted to any other TI intellectual property right or to any third party intellectual property right. TI disclaims responsibility for, and you will fully indemnify TI and its representatives against, any claims, damages, costs, losses, and liabilities arising out of your use of these resources.

TI's products are provided subject to TI's Terms of Sale ([www.ti.com/legal/termsofsale.html](http://www.ti.com/legal/termsofsale.html)) or other applicable terms available either on [ti.com](http://ti.com) or provided in conjunction with such TI products. TI's provision of these resources does not expand or otherwise alter TI's applicable warranties or warranty disclaimers for TI products.

Mailing Address: Texas Instruments, Post Office Box 655303, Dallas, Texas 75265  
Copyright © 2019, Texas Instruments Incorporated

## Looking for pricing, stock, or lifecycle information?

Click below to explore more details on WIN SOURCE:

 [View LM1770TMF/NOPB on WIN SOURCE](#)

 [Texas Instruments](#) Information

## Optimize Your Supply Chain with WIN SOURCE Solutions

-  Global Sourcing Solution
-  Obsolete Management
-  Cost Control Management
-  Shortage Management
-  Alternative Solution
-  Excess Inventory Management