

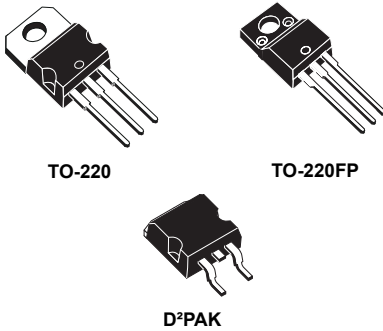

**THE DATASHEET OF  
LM217D2T-TR**



## 1.2 V to 37 V adjustable voltage regulators



### Features

- Output voltage range: 1.2 to 37 V
- Output current in excess of 1.5 A
- 0.1% line and load regulation
- Floating operation for high voltages
- Complete series of protections: current limiting, thermal shutdown and SOA control

### Description

The **LM217**, **LM317** are monolithic integrated circuits in TO-220, TO-220FP and D<sup>2</sup>PAK packages intended for use as positive adjustable voltage regulators.

They are designed to supply more than 1.5 A of load current with an output voltage adjustable over a 1.2 to 37 V range.

The nominal output voltage is selected by means of a resistive divider, making the device exceptionally easy to use and eliminating the stocking of many fixed regulators.

Product status link
<a href="#">LM217</a>
<a href="#">LM317</a>

# 1 Pin configuration

Figure 1. Pin connections (top view)

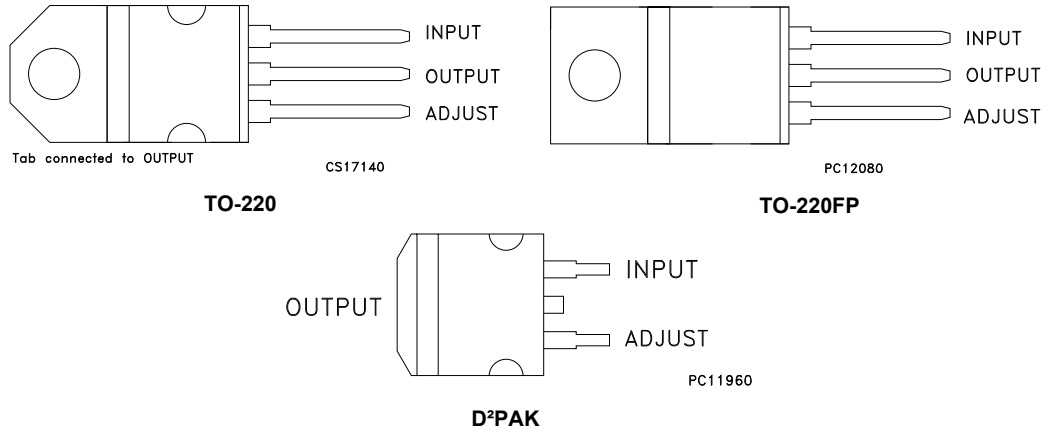

## 2 Maximum ratings

**Table 1. Absolute maximum ratings**

Symbol	Parameter	Value	Unit
$V_I - V_O$	Input-reference differential voltage	40	V
$I_O$	Output current	Internally limited	A
$T_{OP}$	Operating junction temperature for:	LM217	- 25 to 150
		LM317	0 to 125
		LM317B	-40 to 125
$P_D$	Power dissipation	Internally limited	
$T_{STG}$	Storage temperature	- 65 to 150	°C

*Note:* Absolute maximum ratings are those values beyond which damage to the device may occur. Functional operation under these condition is not implied.

**Table 2. Thermal data**

Symbol	Parameter	D <sup>2</sup> PAK	TO-220	TO-220FP	Unit
$R_{thJA}$	Thermal resistance junction-ambient	62.5	50	60	°C/W
$R_{thJC}$	Thermal resistance junction-case	3	5	5	°C/W

### 3 Diagram

Figure 2. Schematic diagram

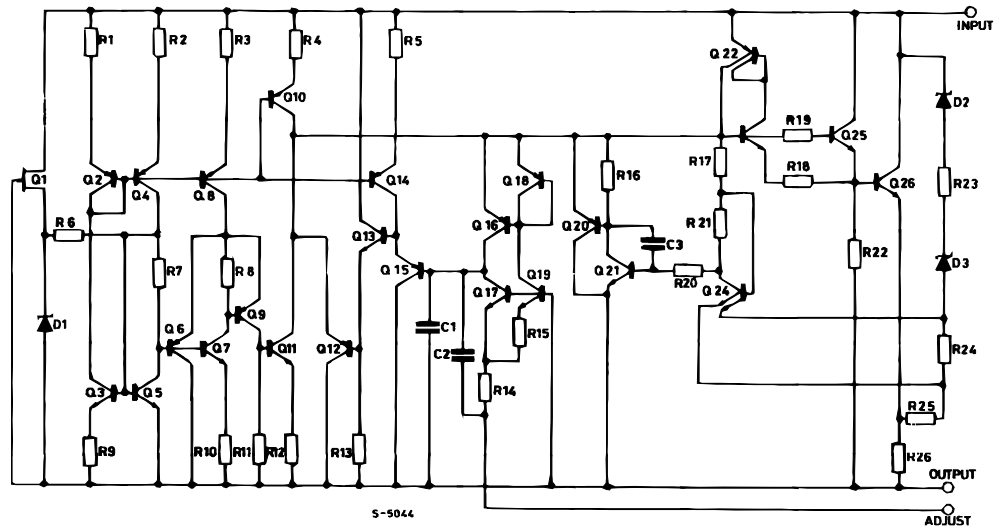

## 4 Electrical characteristics

$V_I - V_O = 5\text{ V}$ ,  $I_O = 500\text{ mA}$ ,  $I_{MAX} = 1.5\text{ A}$  and  $P_{MAX} = 20\text{ W}$ ,  $T_J = -25\text{ to }150\text{ }^\circ\text{C}$ , unless otherwise specified.

**Table 3. Electrical characteristics for LM217**

Symbol	Parameter	Test conditions	Min.	Typ.	Max.	Unit
$\Delta V_O$	Line regulation	$V_I - V_O = 3\text{ to }40\text{ V}$	$T_J = 25^\circ\text{C}$	0.01	0.02	%V
				0.02	0.05	
$\Delta V_O$	Load regulation	$V_O \leq 5\text{ V}$ $I_O = 10\text{ mA to }I_{MAX}$	$T_J = 25^\circ\text{C}$	5	15	mV
				20	50	
		$V_O \geq 5\text{ V}$ , $I_O = 10\text{ mA to }I_{MAX}$	$T_J = 25^\circ\text{C}$	0.1	0.3	%
				0.3	1	
$I_{ADJ}$	Adjustment pin current			50	100	$\mu\text{A}$
$\Delta I_{ADJ}$	Adjustment pin current	$V_I - V_O = 2.5\text{ to }40\text{ V}$ $I_O = 10\text{ mA to }I_{MAX}$		0.2	5	$\mu\text{A}$
$V_{REF}$	Reference voltage	$V_I - V_O = 2.5\text{ to }40\text{ V}$ $I_O = 10\text{ mA to }I_{MAX}$ $P_D \leq P_{MAX}$	1.2	1.25	1.3	V
$\Delta V_O/V_O$	Output voltage temperature stability			1		%
$I_{O(min)}$	Minimum load current	$V_I - V_O = 40\text{ V}$		3.5	5	mA
$I_{O(max)}$	Maximum load current	$V_I - V_O \leq 15\text{ V}$ , $P_D < P_{MAX}$	1.5	2.2		A
		$V_I - V_O = 40\text{ V}$ , $P_D < P_{MAX}$ , $T_J = 25^\circ\text{C}$		0.4		
eN	Output noise voltage (percentage of $V_O$ )	$B = 10\text{ Hz to }100\text{ kHz}$ , $T_J = 25^\circ\text{C}$		0.003		%
SVR	Supply voltage rejection <sup>(1)</sup>	$T_J = 25^\circ\text{C}$ , $f = 120\text{ Hz}$	$C_{ADJ} = 0$		65	dB
			$C_{ADJ} = 10\text{ }\mu\text{F}$	66	80	

1.  $C_{ADJ}$  is connected between adjust pin and ground.

$V_I - V_O = 5\text{ V}$ ,  $I_O = 500\text{ mA}$ ,  $I_{MAX} = 1.5\text{ A}$  and  $P_{MAX} = 20\text{ W}$ ,  $T_J = 0\text{ to }125\text{ }^\circ\text{C}$ , unless otherwise specified.

**Table 4. Electrical characteristics for LM317**

Symbol	Parameter	Test conditions	Min.	Typ.	Max.	Unit
$\Delta V_O$	Line regulation	$V_I - V_O = 3\text{ to }40\text{ V}$	$T_J = 25^\circ\text{C}$	0.01	0.04	%V
				0.02	0.07	
$\Delta V_O$	Load regulation	$V_O \leq 5\text{ V}$ $I_O = 10\text{ mA to }I_{MAX}$	$T_J = 25^\circ\text{C}$	5	25	mV
				20	70	
		$V_O \geq 5\text{ V}$ , $I_O = 10\text{ mA to }I_{MAX}$	$T_J = 25^\circ\text{C}$	0.1	0.5	%
				0.3	1.5	
$I_{ADJ}$	Adjustment pin current			50	100	$\mu\text{A}$
$\Delta I_{ADJ}$	Adjustment pin current	$V_I - V_O = 2.5\text{ to }40\text{ V}$ $I_O = 10\text{ mA to }I_{MAX}$		0.2	5	$\mu\text{A}$
$V_{REF}$	Reference voltage (between pin 3 and pin 1)	$V_I - V_O = 2.5\text{ to }40\text{ V}$ $I_O = 10\text{ mA to }I_{MAX}$ $P_D \leq P_{MAX}$	1.2	1.25	1.3	V
$\Delta V_O/V_O$	Output voltage temperature stability			1		%
$I_{O(min)}$	Minimum load current	$V_I - V_O = 40\text{ V}$		3.5	10	mA
$I_{O(max)}$	Maximum load current	$V_I - V_O \leq 15\text{ V}$ , $P_D < P_{MAX}$	1.5	2.2		A
		$V_I - V_O = 40\text{ V}$ , $P_D < P_{MAX}$ , $T_J = 25^\circ\text{C}$	0.4			
eN	Output noise voltage (percentage of $V_O$ )	$B = 10\text{ Hz to }100\text{ kHz}$ , $T_J = 25^\circ\text{C}$		0.003		%
SVR	Supply voltage rejection <sup>(1)</sup>	$T_J = 25^\circ\text{C}$ , $f = 120\text{ Hz}$	$C_{ADJ} = 0$		65	dB
			$C_{ADJ} = 10\text{ }\mu\text{F}$	66	80	

1.  $C_{ADJ}$  is connected between adjust pin and ground.

$V_I - V_O = 5\text{ V}$ ,  $I_O = 500\text{ mA}$ ,  $I_{MAX} = 1.5\text{ A}$  and  $P_{MAX} = 20\text{ W}$ ,  $T_J = -40\text{ to }125\text{ }^\circ\text{C}$ , unless otherwise specified.

**Table 5. Electrical characteristics for LM317B**

Symbol	Parameter	Test conditions	Min.	Typ.	Max.	Unit	
$\Delta V_O$	Line regulation	$V_I - V_O = 3\text{ to }40\text{ V}$		$T_J = 25^\circ\text{C}$	0.01	0.04	%V
					0.02	0.07	
$\Delta V_O$	Load regulation	$V_O \leq 5\text{ V}$ $I_O = 10\text{ mA to }I_{MAX}$		$T_J = 25^\circ\text{C}$	5	25	mV
					20	70	
		$V_O \geq 5\text{ V}$ , $I_O = 10\text{ mA to }I_{MAX}$		$T_J = 25^\circ\text{C}$	0.1	0.5	%
					0.3	1.5	
$I_{ADJ}$	Adjustment pin current			50	100	$\mu\text{A}$	
$\Delta I_{ADJ}$	Adjustment pin current	$V_I - V_O = 2.5\text{ to }40\text{ V}$ $I_O = 10\text{ mA to }500\text{ mA}$		0.2	5	$\mu\text{A}$	
$V_{REF}$	Reference voltage (between pin 3 and pin 1)	$V_I - V_O = 2.5\text{ to }40\text{ V}$ $I_O = 10\text{ mA to }500\text{ mA}$ $P_D \leq P_{MAX}$	1.2	1.25	1.3	V	
$\Delta V_O/V_O$	Output voltage temperature stability			1		%	
$I_{O(min)}$	Minimum load current	$V_I - V_O = 40\text{ V}$		3.5	10	mA	
$I_{O(max)}$	Maximum load current	$V_I - V_O \leq 15\text{ V}$ , $P_D < P_{MAX}$	1.5	2.2		A	
		$V_I - V_O = 40\text{ V}$ , $P_D < P_{MAX}$ , $T_J = 25^\circ\text{C}$	0.4				
eN	Output noise voltage (percentage of $V_O$ )	$B = 10\text{ Hz to }100\text{ kHz}$ , $T_J = 25^\circ\text{C}$		0.003		%	
SVR	Supply voltage rejection <sup>(1)</sup>	$T_J = 25^\circ\text{C}$ , $f = 120\text{ Hz}$	$C_{ADJ} = 0$		65	dB	
			$C_{ADJ} = 10\text{ }\mu\text{F}$	66	80		

1.  $C_{ADJ}$  is connected between adjust pin and ground.

## 5 Typical characteristics

Figure 3. Output current vs. input-output differential voltage

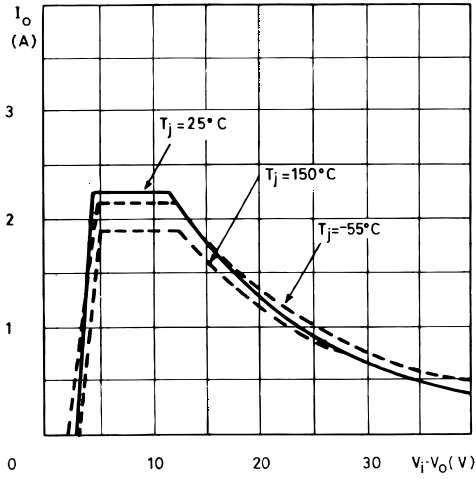

Figure 4. Dropout voltage vs. junction temperature

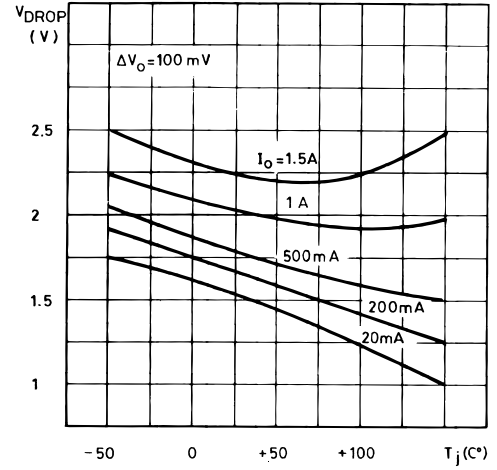

Figure 5. Reference voltage vs. junction

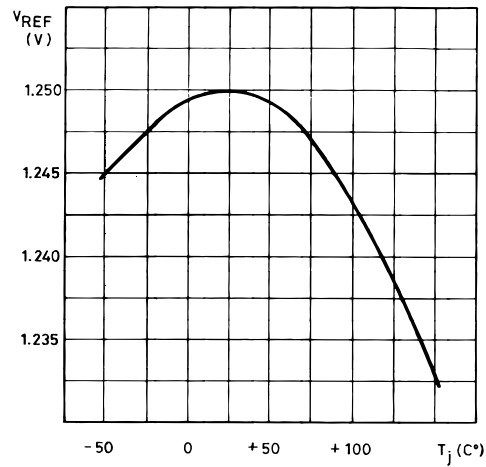
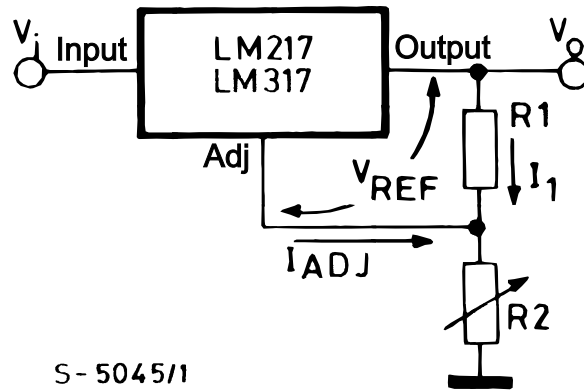

Figure 6. Basic adjustable regulator



S-5045/1

## 6 Application information

The LM217, LM317 provides an internal reference voltage of 1.25 V between the output and adjustments terminals. This is used to set a constant current flow across an external resistor divider (see [Figure 6. Basic adjustable regulator](#)), giving an output voltage  $V_O$  of:

$$V_O = V_{REF} (1 + R_2/R_1) + I_{ADJ} R_2$$

The device was designed to minimize the term  $I_{ADJ}$  (100  $\mu$ A max) and to maintain it very constant with line and load changes. Usually, the error term  $I_{ADJ} \times R_2$  can be neglected. To obtain the previous requirement, all the regulator quiescent current is returned to the output terminal, imposing a minimum load current condition. If the load is insufficient, the output voltage will rise. Since the LM217, LM317 is a floating regulator and "sees" only the input-to- output differential voltage, supplies of very high voltage with respect to ground can be regulated as long as the maximum input-to-output differential is not exceeded. Furthermore, programmable regulators are easily obtainable and, by connecting a fixed resistor between the adjustment and output, the device can be used as a precision current regulator. In order to optimize the load regulation, the current set resistor  $R_1$  (see [Figure 6. Basic adjustable regulator](#)) should be tied as close as possible to the regulator, while the ground terminal of  $R_2$  should be near the ground of the load to provide remote ground sensing. Performance may be improved with added capacitance as follow:

- An input bypass capacitor of 0.1  $\mu$ F
- An adjustment terminal to ground 10  $\mu$ F capacitor to improve the ripple rejection of about 15 dB ( $C_{ADJ}$ ).
- An 1  $\mu$ F tantalum (or 25  $\mu$ F Aluminium electrolytic) capacitor on the output to improve transient response. In addition to external capacitors, it is good practice to add protection diodes, as shown in figure below D1 protect the device against input short circuit, while D2 protect against output short circuit for capacitance discharging.

**Figure 7. Voltage regulator with protection diodes**

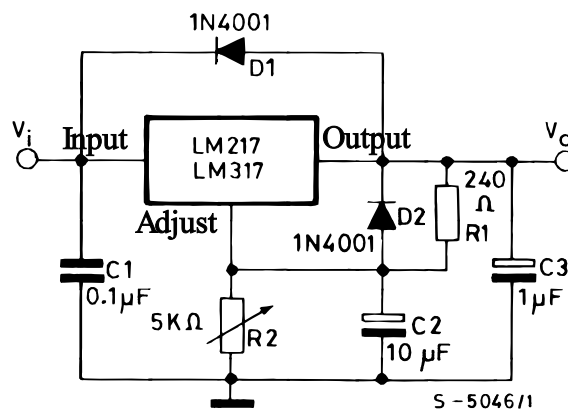

*Note:* D1 protect the device against input short circuit, while D2 protects against output short circuit for capacitors discharging.

Figure 8. Slow turn-on 15 V regulator

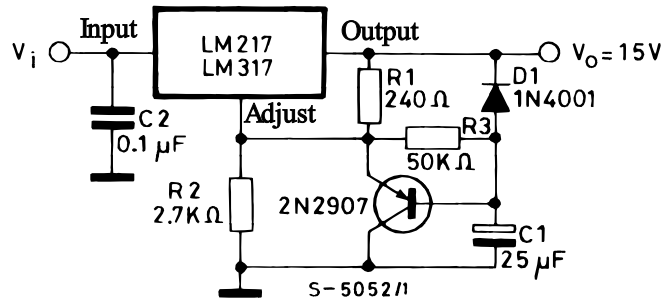
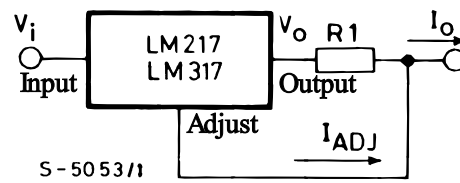

Figure 9. Current regulator



$$I_O = (V_{REF} / R_1) + I_{ADJ} = 1.25 \text{ V} / R_1$$

Figure 10. 5 V electronic shut-down regulator

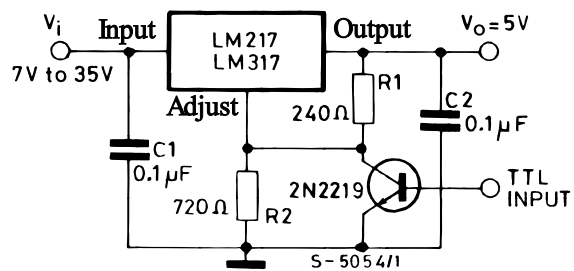
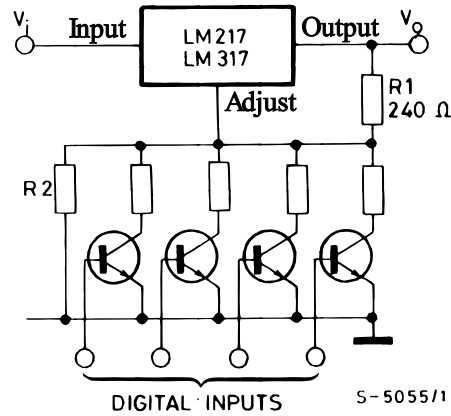
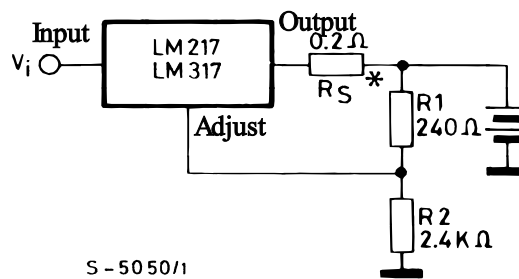

Figure 11. Digitally selected outputs



(R<sub>2</sub> sets maximum V<sub>O</sub>)

Figure 12. Battery charger (12 V)



\* R<sub>S</sub> sets output impedance of charger  $Z_O = R_S (1 + R_2 / R_1)$ . Use of R<sub>S</sub> allows low charging rates whit fully charged battery.

Figure 13. Current limited 6 V charger

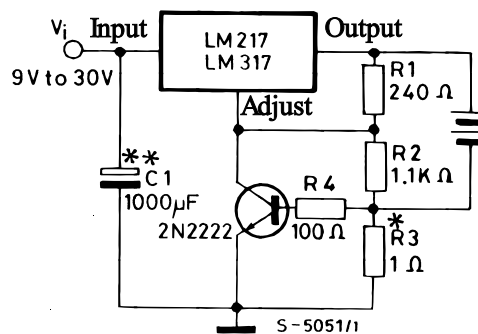

\* R<sub>3</sub> sets peak current (0.6 A for 10).

\*\* C<sub>1</sub> recommended to filter out input transients.

## 7 Device summary

Table 6. Device summary

Order codes			
TO-220 (single gauge)	TO-220 (double gauge)	D <sup>2</sup> PAK (tape and reel)	TO-220FP
LM217T	LM217T-DG	LM217D2T-TR	
LM317T	LM317T-DG	LM317D2T-TR	LM317P
LM317BT			

## 8 Package information

In order to meet environmental requirements, ST offers these devices in different grades of **ECOPACK** packages, depending on their level of environmental compliance. ECOPACK specifications, grade definitions and product status are available at: [www.st.com](http://www.st.com). ECOPACK is an ST trademark.

### 8.1 TO-220 (single gauge) package information

Figure 14. TO-220 (single gauge) package outline

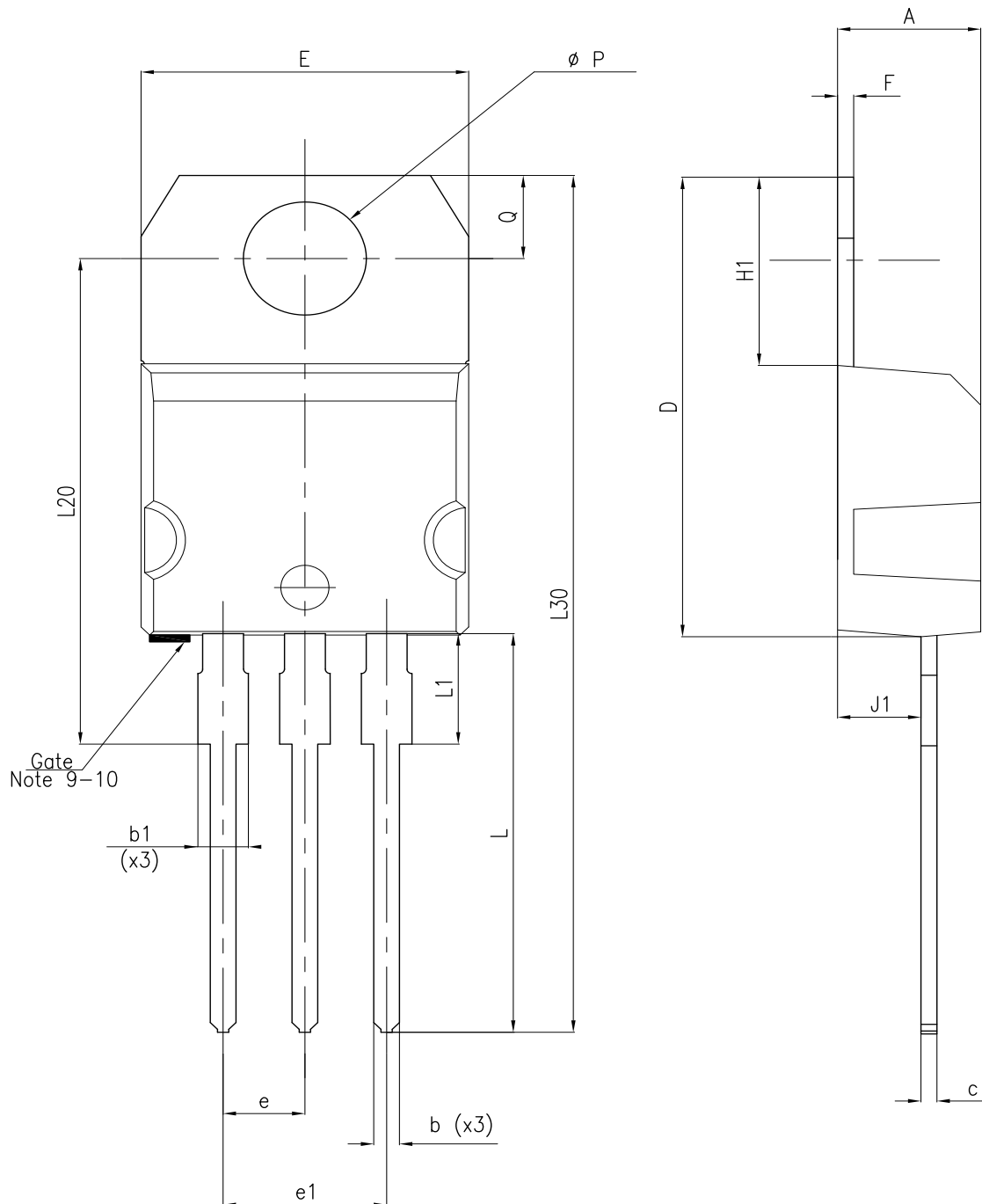

8174627\_5

**Table 7. TO-220 (single gauge) mechanical data**

Dim.	mm		
	Min.	Typ.	Max.
A	4.40		4.60
b	0.61		0.88
b1	1.14		1.70
c	0.48		0.70
D	15.25		15.75
E	10.00		10.40
e	2.40		2.70
e1	4.95		5.15
F	0.51		0.60
H1	6.20		6.60
J1	2.40		2.72
L	13.00		14.00
L1	3.50		3.93
L20		16.40	
L30		28.90	
ØP	3.75		3.85
Q	2.65		2.95

## 8.2 TO-220 (dual gauge) package information

Figure 15. TO-220 (dual gauge) package outline

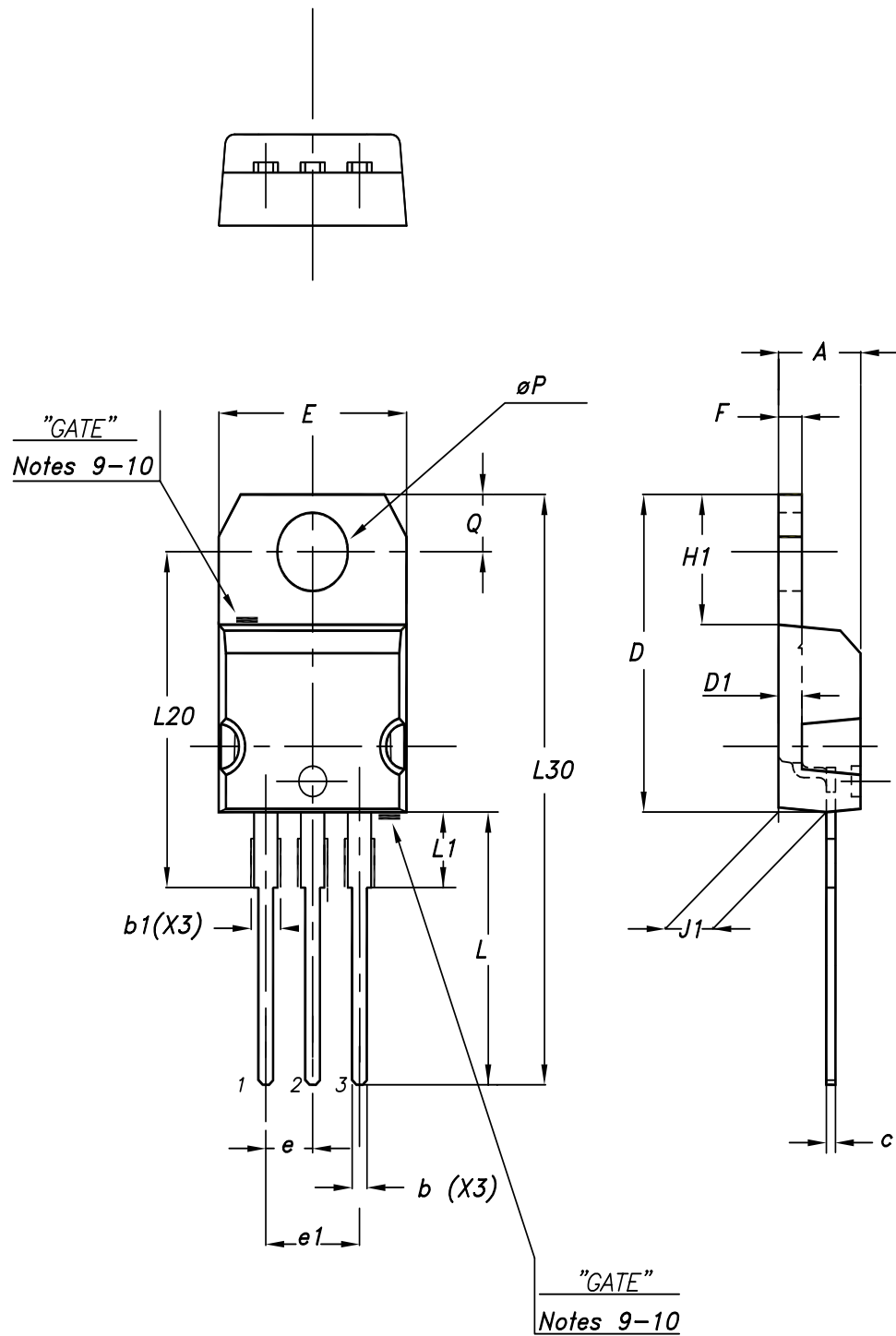

0015988\_21\_Type A

**Table 8. TO-220 (dual gauge) mechanical data**

Dim.	mm		
	Min.	Typ.	Max.
A	4.40		4.60
b	0.61		0.88
b1	1.14		1.70
c	0.48		0.70
D	15.25		15.75
D1		1.27	
E	10		10.40
e	2.40		2.70
e1	4.95		5.15
F	1.23		1.32
H1	6.20		6.60
J1	2.40		2.72
L	13		14
L1	3.50		3.93
L20		16.40	
L30		28.90	
ØP	3.75		3.85
Q	2.65		2.95

### 8.3 TO-220FP type A package information

Figure 16. TO-220FP package outline

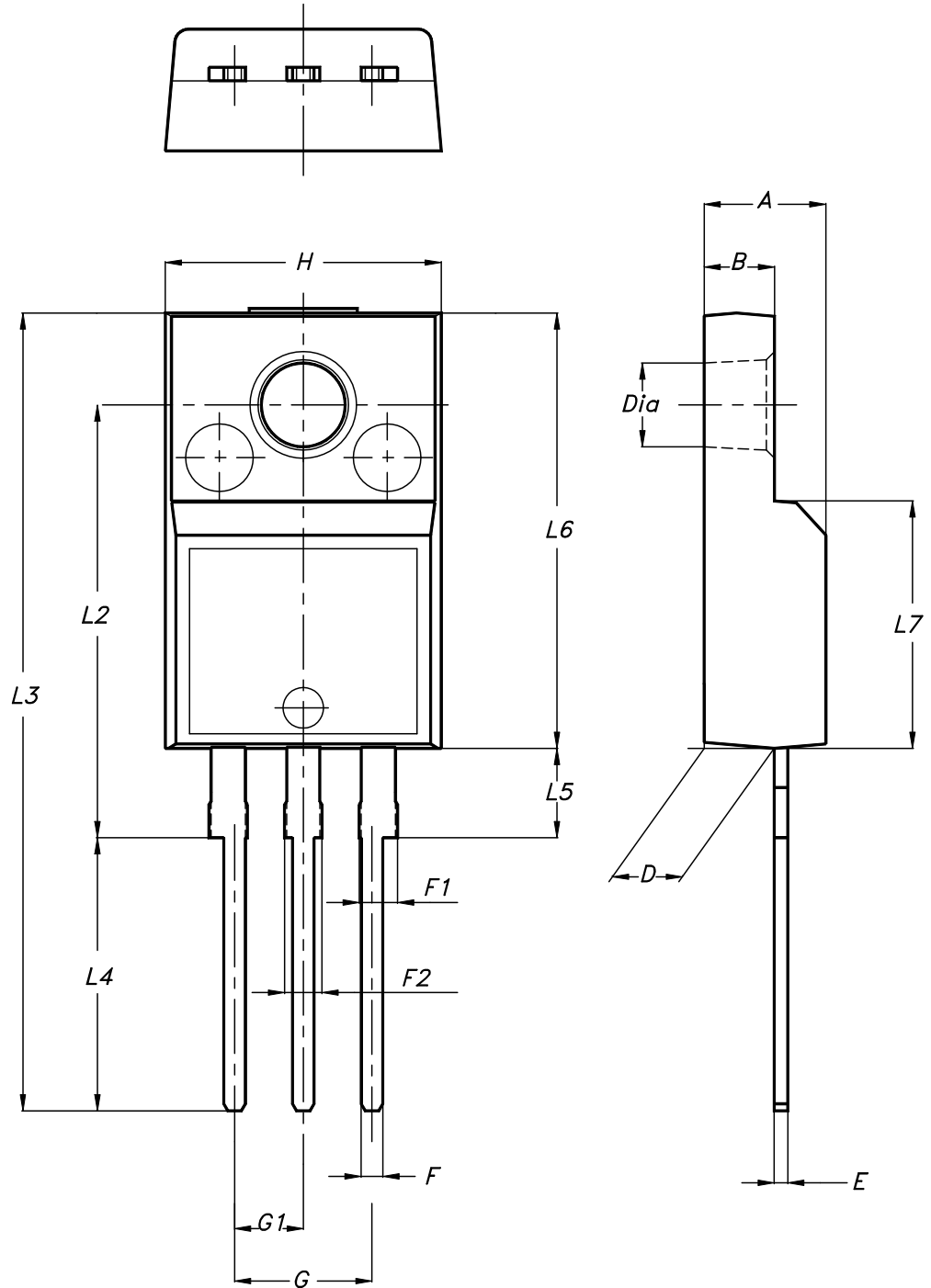

7012510\_type\_A

**Table 9. TO-220FP package mechanical data**

Dim.	mm		
	Min.	Typ.	Max.
A	4.4		4.6
B	2.5		2.7
D	2.5		2.75
E	0.45		0.7
F	0.75		1
F1	1.15		1.70
F2	1.15		1.70
G	4.95		5.2
G1	2.4		2.7
H	10		10.4
L2		16	
L3	28.6		30.6
L4	9.8		10.6
L5	2.9		3.6
L6	15.9		16.4
L7	9		9.3
Dia	3		3.2

### 8.4 D<sup>2</sup>PAK (SMD 2L STD-ST) type A package information

Figure 17. D<sup>2</sup>PAK (SMD 2L STD-ST) type A package outline

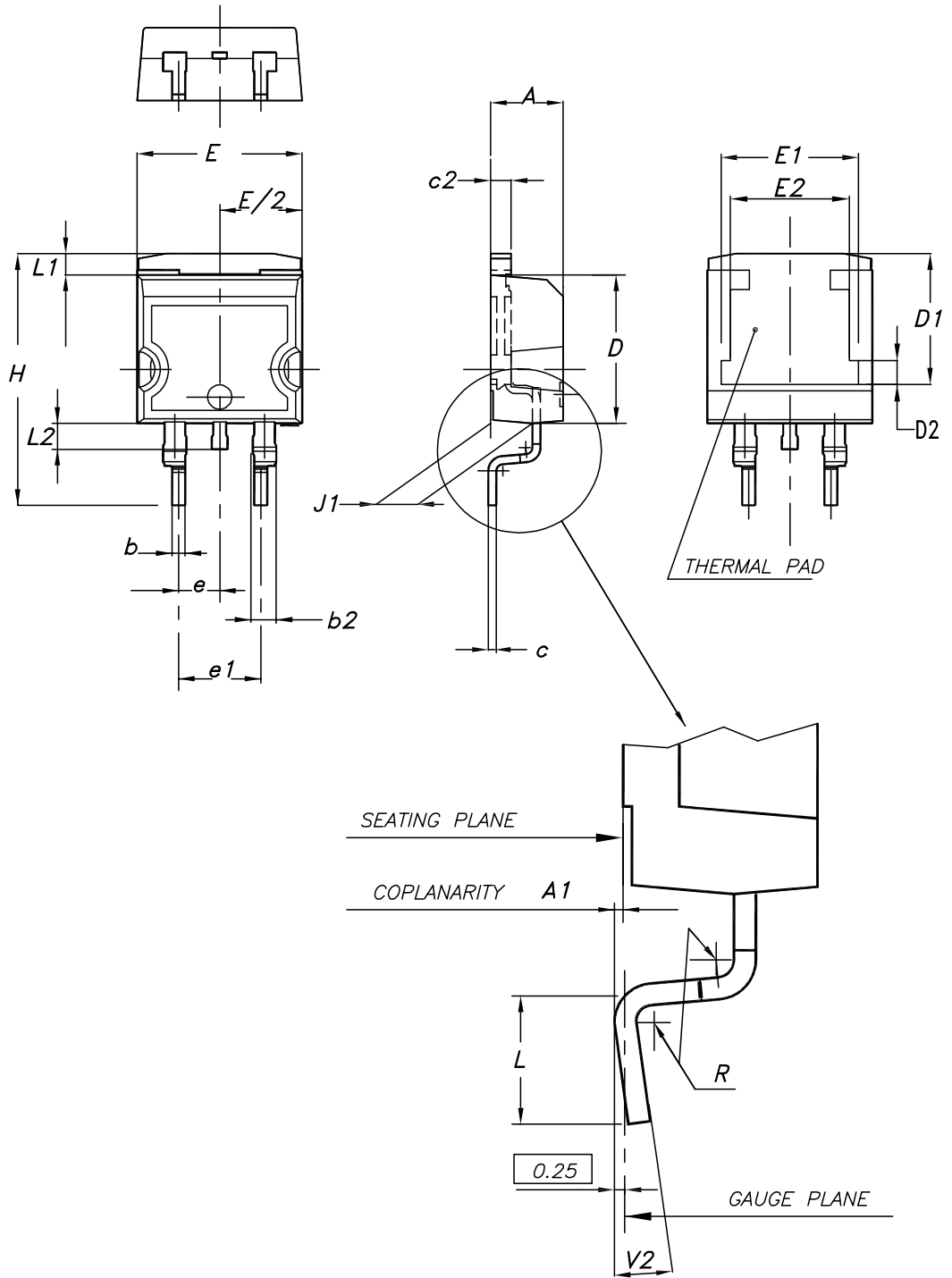

0079457\_22\_type A

**Table 10. D<sup>2</sup>PAK (SMD 2L STD-ST) mechanical data**

Dim.	mm		
	Min.	Typ.	Max.
A	4.40		4.60
A1	0.03		0.23
b	0.70		0.93
b2	1.14		1.70
c	0.45		0.60
c2	1.23		1.36
D	8.95		9.35
D1	7.50	7.75	8.00
D2	1.10	1.30	1.50
E	10		10.40
E1	8.50	8.70	8.90
E2	6.85	7.05	7.25
e		2.54	
e1	4.88		5.28
H	15		15.85
J1	2.49		2.69
L	2.29		2.79
L1	1.27		1.40
L2	1.30		1.75
R		0.4	
V2	0°		8°

## 8.5 D<sup>2</sup>PAK (ASE) type B package information

Figure 18. D<sup>2</sup>PAK (ASE subcon) type B package outline

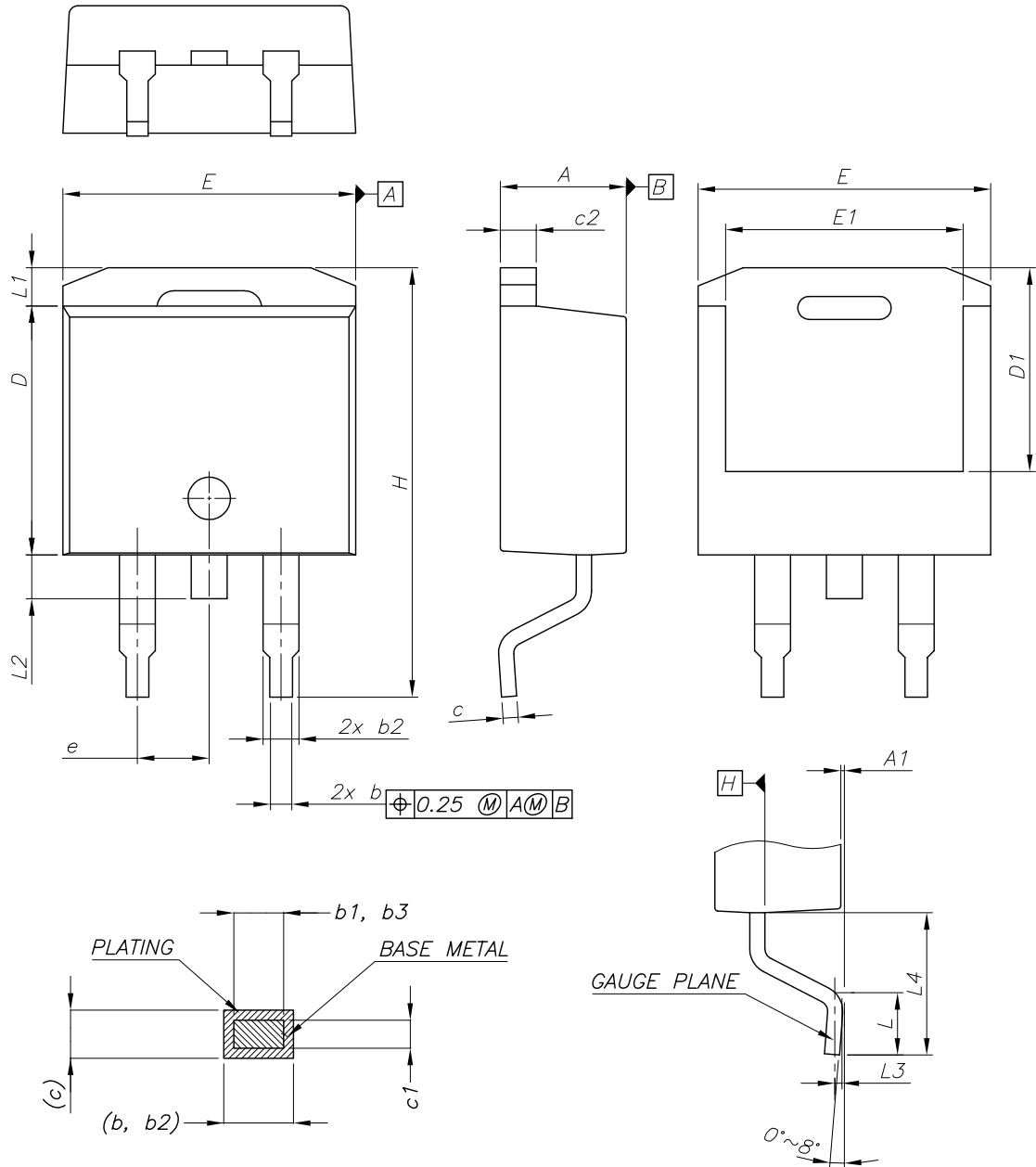

0079457\_23\_type B

**Table 11. D<sup>2</sup>PAK (ASE) type B mechanical data**

Dim.	mm		
	Min.	Typ.	Max.
A	4.36		4.56
A1	0		0.25
b	0.70		0.90
b1	0.51		0.89
b2	1.17		1.37
b3	1.36		1.46
c	0.38		0.694
c1	0.38		0.534
c2	1.19		1.34
D	8.60		9.00
D1	6.90		7.50
E	10.15		10.55
E1	8.10		8.70
e		2.54	
H	15.00		15.60
L	1.90		2.50
L1			1.65
L2			1.78
L3		0.25	
L4	4.78		5.28

Figure 19. D<sup>2</sup>PAK recommended footprint (dimensions are in mm)

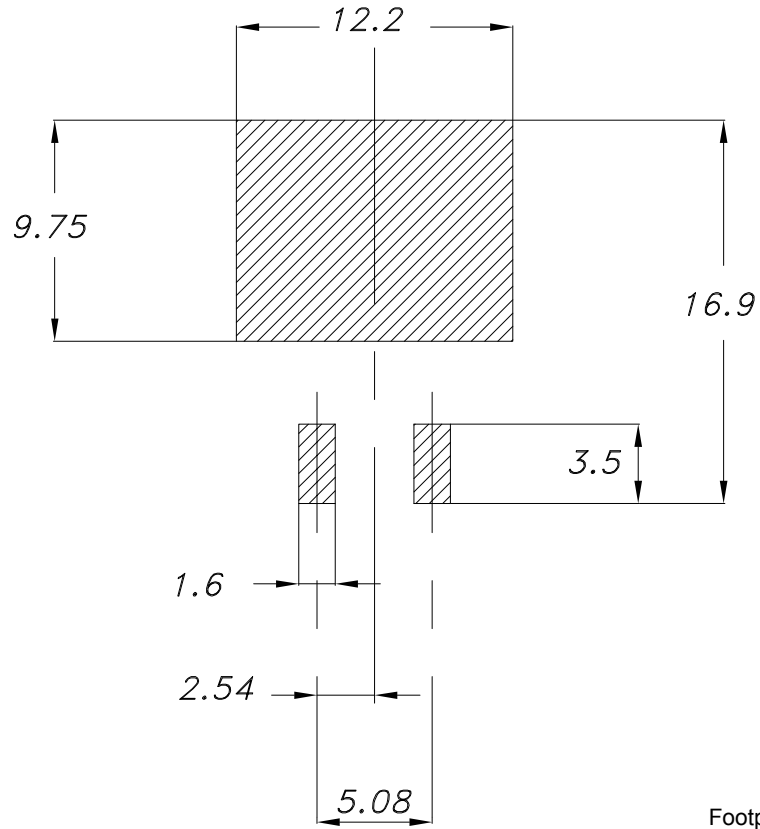

Footprint\_0079457

## 8.6 D<sup>2</sup>PAK packaging information

Figure 20. D<sup>2</sup>PAK tape outline

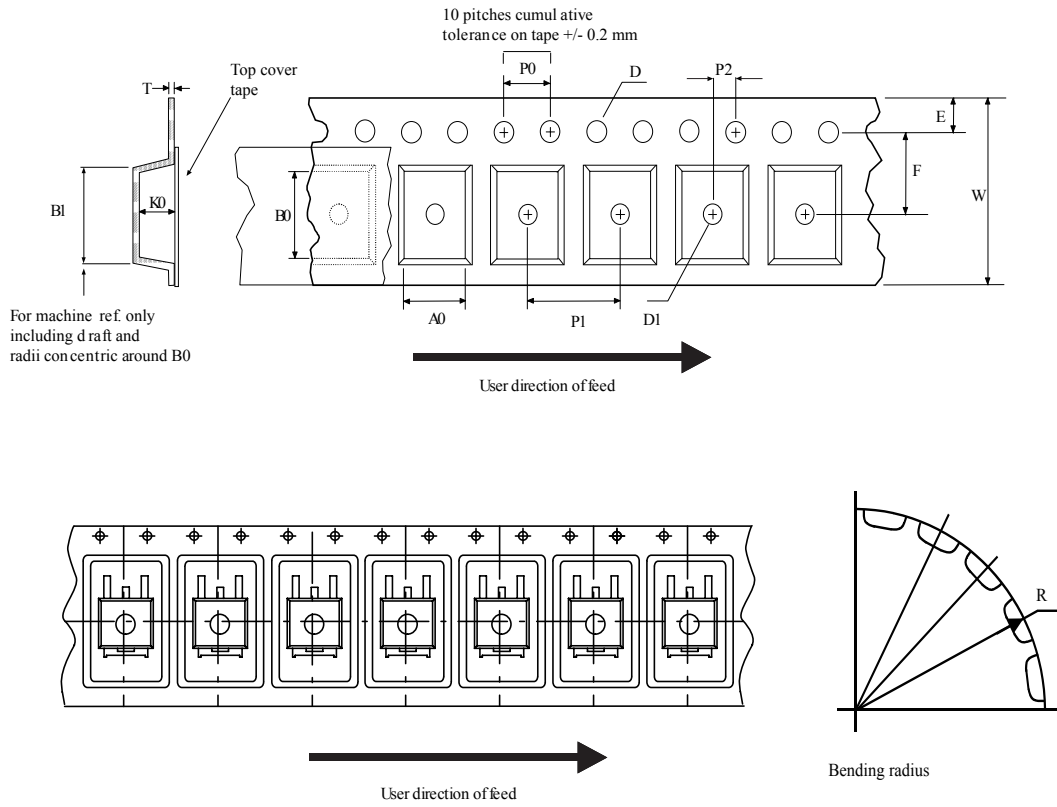

Figure 21. Reel for D<sup>2</sup>PAK

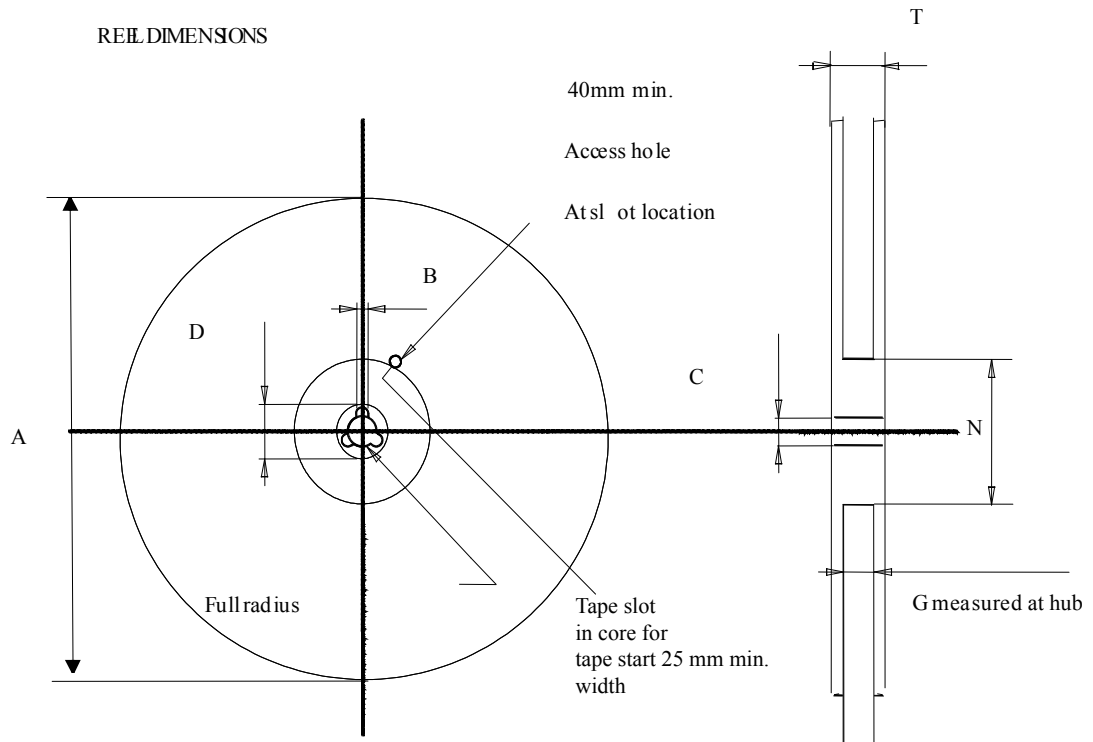

Table 12. D<sup>2</sup>PAK tape and reel mechanical data

Dim.	Tape		Dim.	Reel	
	mm			mm	
	Min.	Max.		Min.	Max.
A0	10.5	10.7	A		330
B0	15.7	15.9	B	1.5	
D	1.5	1.6	C	12.8	13.2
D1	1.59	1.61	D	20.2	
E	1.65	1.85	G	24.4	26.4
F	11.4	11.6	N	100	
K0	4.8	5.0	T		30.4
P0	3.9	4.1			
P1	11.9	12.1	Base qty		1000
P2	1.9	2.1	Bulk qty		1000
R	50				
T	0.25	0.35			
W	23.7	24.3			

## Revision history

**Table 13. Document revision history**

Date	Revision	Changes
01-Sep-2004	10	Mistake VREF==> V <sub>O</sub> , tables 1, 4 and 5.
19-Jan-2007	11	D <sup>2</sup> PAK mechanical data has been updated, add footprint data and the document has been reformatted.
13-Jun-2007	12	Change values ΔI <sub>ADJ</sub> and V <sub>REF</sub> test condition of I <sub>O</sub> = 10 mA to I <sub>MAX</sub> ==> I <sub>O</sub> = 10 mA to 500 mA on Table 5.
23-Nov-2007	13	Added Table 1.
06-Feb-2008	14	Added: TO-220 mechanical data Figure 14 on page 14 and Table 6 on page 13.
02-Mar-2010	15	Added: notes Figure 14 on page 14, Figure 15 on page 15, Figure 16 and Figure 17 on page 16.
17-Nov-2010	16	Modified: R <sub>thJC</sub> value for TO-220 Table 3 on page 4.
18-Nov-2011	17	Added: order code LM317T-DG Table 1 on page 1.
13-Feb-2012	18	Added: order code LM217T-DG Table 1 on page 1.
12-Mar-2014	19	<p>The part number LM117 has been moved to a separate datasheet. Removed TO-3 package.</p> <p>Updated the description in cover page</p> <p>Modified Table 1: Device summary, Table 3: Thermal data, Figure 1: Pin connections (top view), Section 4: Electrical characteristics, Section 5: Typical characteristics, Section 6: Application information, Section 7: Package mechanical data.</p> <p>Added Section 8: Packaging mechanical data. Minor text changes.</p>
28-May-2018	20	Updated Section 8.5 D <sup>2</sup> PAK (ASE) type B package information.
31-Jul-2019	21	Updated T <sub>OP</sub> unit in Table 1. <a href="#">Absolute maximum ratings</a> .

## Contents

<b>1</b>	<b>Pin configuration</b> .....	<b>2</b>
<b>2</b>	<b>Maximum ratings</b> .....	<b>3</b>
<b>3</b>	<b>Diagram</b> .....	<b>4</b>
<b>4</b>	<b>Electrical characteristics</b> .....	<b>5</b>
<b>5</b>	<b>Typical characteristics</b> .....	<b>8</b>
<b>6</b>	<b>Application information</b> .....	<b>10</b>
<b>7</b>	<b>Device summary</b> .....	<b>13</b>
<b>8</b>	<b>Package information</b> .....	<b>14</b>
8.1	TO-220 (single gauge) package information .....	14
8.2	TO-220 (dual gauge) package information .....	15
8.3	TO-220FP type A package information .....	17
8.4	D <sup>2</sup> PAK (SMD 2L STD-ST) type A package information .....	19
8.5	D <sup>2</sup> PAK (ASE) type B package information .....	21
8.6	D <sup>2</sup> PAK packing information .....	24
	<b>Revision history</b> .....	<b>27</b>

## List of tables

<b>Table 1.</b>	Absolute maximum ratings . . . . .	3
<b>Table 2.</b>	Thermal data . . . . .	3
<b>Table 3.</b>	Electrical characteristics for LM217 . . . . .	5
<b>Table 4.</b>	Electrical characteristics for LM317 . . . . .	6
<b>Table 5.</b>	Electrical characteristics for LM317B . . . . .	7
<b>Table 6.</b>	Device summary . . . . .	13
<b>Table 7.</b>	TO-220 (single gauge) mechanical data . . . . .	15
<b>Table 8.</b>	TO-220 (dual gauge) mechanical data . . . . .	17
<b>Table 9.</b>	TO-220FP package mechanical data . . . . .	19
<b>Table 10.</b>	D <sup>2</sup> PAK (SMD 2L STD-ST) mechanical data . . . . .	21
<b>Table 11.</b>	D <sup>2</sup> PAK (ASE) type B mechanical data . . . . .	23
<b>Table 12.</b>	D <sup>2</sup> PAK tape and reel mechanical data . . . . .	26
<b>Table 13.</b>	Document revision history . . . . .	27

## List of figures

Figure 1.	Pin connections (top view) . . . . .	2
Figure 2.	Schematic diagram . . . . .	4
Figure 3.	Output current vs. input-output differential voltage . . . . .	8
Figure 4.	Dropout voltage vs. junction temperature . . . . .	8
Figure 5.	Reference voltage vs. junction . . . . .	8
Figure 6.	Basic adjustable regulator . . . . .	9
Figure 7.	Voltage regulator with protection diodes . . . . .	10
Figure 8.	Slow turn-on 15 V regulator . . . . .	11
Figure 9.	Current regulator . . . . .	11
Figure 10.	5 V electronic shut-down regulator . . . . .	11
Figure 11.	Digitally selected outputs . . . . .	12
Figure 12.	Battery charger (12 V) . . . . .	12
Figure 13.	Current limited 6 V charger. . . . .	12
Figure 14.	TO-220 (single gauge) package outline . . . . .	14
Figure 15.	TO-220 (dual gauge) package outline . . . . .	16
Figure 16.	TO-220FP package outline. . . . .	18
Figure 17.	D <sup>2</sup> PAK (SMD 2L STD-ST) type A package outline . . . . .	20
Figure 18.	D <sup>2</sup> PAK (ASE subcon) type B package outline . . . . .	22
Figure 19.	D <sup>2</sup> PAK recommended footprint (dimensions are in mm) . . . . .	24
Figure 20.	D <sup>2</sup> PAK tape outline . . . . .	25
Figure 21.	Reel for D <sup>2</sup> PAK . . . . .	26

**IMPORTANT NOTICE – PLEASE READ CAREFULLY**

STMicroelectronics NV and its subsidiaries (“ST”) reserve the right to make changes, corrections, enhancements, modifications, and improvements to ST products and/or to this document at any time without notice. Purchasers should obtain the latest relevant information on ST products before placing orders. ST products are sold pursuant to ST’s terms and conditions of sale in place at the time of order acknowledgement.

Purchasers are solely responsible for the choice, selection, and use of ST products and ST assumes no liability for application assistance or the design of Purchasers’ products.

No license, express or implied, to any intellectual property right is granted by ST herein.

Resale of ST products with provisions different from the information set forth herein shall void any warranty granted by ST for such product.

ST and the ST logo are trademarks of ST. For additional information about ST trademarks, please refer to [www.st.com/trademarks](http://www.st.com/trademarks). All other product or service names are the property of their respective owners.

Information in this document supersedes and replaces information previously supplied in any prior versions of this document.







© 2019 STMicroelectronics – All rights reserved

## Looking for pricing, stock, or lifecycle information?

Click below to explore more details on WIN SOURCE:

-  [View LM217D2T-TR on WIN SOURCE](#)
-  [STMicroelectronics Information](#)

## Optimize Your Supply Chain with WIN SOURCE Solutions

-  Global Sourcing Solution
-  Obsolete Management
-  Cost Control Management
-  Shortage Management
-  Alternative Solution
-  Excess Inventory Management