



**THE DATASHEET OF
LM2599SX-ADJ/NOPB**



LM2599 SIMPLE SWITCHER® Power Converter 150-kHz 3-A Step-Down Voltage Regulator, With Features

1 Features

- 3.3-V, 5-V, 12-V, and Adjustable Output Versions
- Adjustable Version Output Voltage Range: 1.2 V to 37 V $\pm 4\%$ Maximum Over Line and Load Conditions
- 3-A Output Current
- Available in 7-Pin TO-220 and TO-263 (Surface-Mount) Package
- Input Voltage Range Up to 40 V
- 150-kHz Fixed-Frequency Internal Oscillator
- Shutdown and Soft-Start
- Out-of-Regulation Error Flag
- Error Output Delay
- Low Power Standby Mode, I_{Q} , Typically 80 μ A
- High Efficiency
- Uses Readily Available Standard Inductors
- Thermal Shutdown and Current-Limit Protection

2 Applications

- Simple High-Efficiency Step-Down (Buck) Regulator
- Efficient Preregulator for Linear Regulators
- On-Card Switching Regulators
- Positive to Negative Converter

3 Description

The LM2599 series of regulators are monolithic integrated circuits that provide all the active functions for a step-down (buck) switching regulator, capable of driving a 3-A load with excellent line and load regulation. These devices are available in fixed output voltages of 3.3 V, 5 V, 12 V, and an adjustable output version.

The LM2598 is a member of the LM259x family, with additional supervisory and performance features added.

Requiring a minimum number of external components, these regulators are simple to use and include internal frequency compensation, improved line and load specifications, fixed-frequency oscillator, Shutdown and Soft-start, error flag delay, and error flag output.

Device Information⁽¹⁾

PART NUMBER	PACKAGE	BODY SIZE (NOM)
LM2599	TO-220 (7)	14.986 mm x 10.16 mm
	TO-263 (7)	10.10 mm x 8.89 mm

(1) For all available packages, see the orderable addendum at the end of the data sheet.

Typical Application

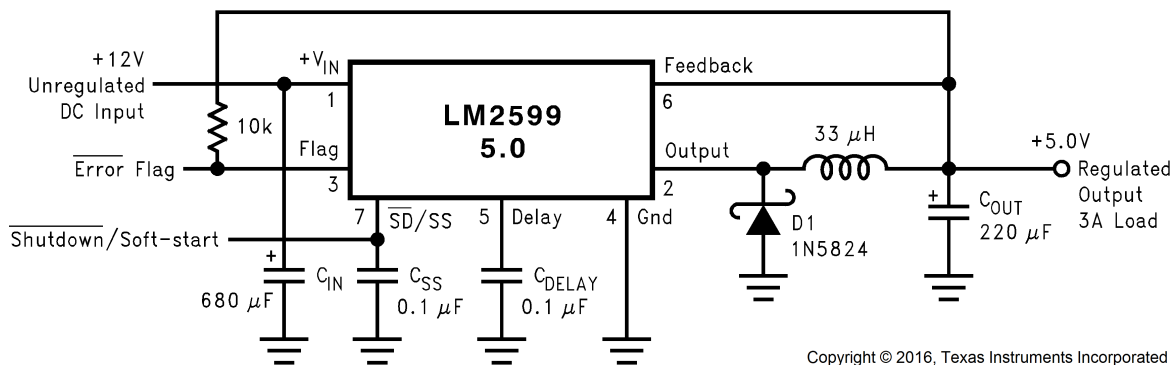

Copyright © 2016, Texas Instruments Incorporated

(fixed output voltage versions)



Table of Contents

1 Features 1 2 Applications 1 3 Description 1 4 Revision History 2 5 Description (continued) 3 6 Pin Configuration and Functions 3 7 Specifications 4 7.1 Absolute Maximum Ratings 4 7.2 ESD Ratings 4 7.3 Recommended Operating Conditions 4 7.4 Thermal Information 4 7.5 Electrical Characteristics – 3.3-V Version 5 7.6 Electrical Characteristics – 5-V Version 5 7.7 Electrical Characteristics – 12-V Version 5 7.8 Electrical Characteristics – Adjustable Voltage Version 5 7.9 Electrical Characteristics – All Output Voltage Versions 6 7.10 Typical Characteristics 7 8 Detailed Description 10	8.1 Overview 10 8.2 Functional Block Diagram 10 8.3 Feature Description 10 8.4 Device Functional Modes 15 9 Application and Implementation 16 9.1 Application Information 16 9.2 Typical Applications 25 10 Power Supply Recommendations 34 11 Layout 34 11.1 Layout Guidelines 34 11.2 Layout Examples 34 11.3 Thermal Considerations 35 12 Device and Documentation Support 38 12.1 Community Resources 38 12.2 Trademarks 38 12.3 Electrostatic Discharge Caution 38 12.4 Glossary 38 13 Mechanical, Packaging, and Orderable Information 38
--	--

4 Revision History

NOTE: Page numbers for previous revisions may differ from page numbers in the current version.

Changes from Revision C (April 2013) to Revision D	Page
<ul style="list-style-type: none"> • Added <i>ESD Ratings</i> table, <i>Feature Description</i> section, <i>Device Functional Modes</i>, <i>Application and Implementation</i> section, <i>Power Supply Recommendations</i> section, <i>Layout</i> section, <i>Device and Documentation Support</i> section, and <i>Mechanical, Packaging, and Orderable Information</i> section. 1 • Removed all references to design software <i>Switchers Made Simple</i> 1 	

Changes from Revision B (April 2013) to Revision C	Page
<ul style="list-style-type: none"> • Changed layout of National Semiconductor Data Sheet to TI format 35 	

5 Description (continued)

The LM2599 series operates at a switching frequency of 150 kHz, thus allowing smaller sized filter components than what would be needed with lower frequency switching regulators. Available in a standard 7-pin TO-220 package with several different lead bend options, and a 7-pin TO-263 surface-mount package.

A standard series of inductors (both through-hole and surface-mount types) are available from several different manufacturers optimized for use with the LM2599 series. This feature greatly simplifies the design of switch-mode power supplies.

Other features include a $\pm 4\%$ tolerance on output voltage under all conditions of input voltage and output load conditions, and $\pm 15\%$ on the oscillator frequency. External shutdown is included, featuring typically 80- μ A standby current. Self-protection features include a two stage current limit for the output switch and an overtemperature shutdown for complete protection under fault conditions.

6 Pin Configuration and Functions

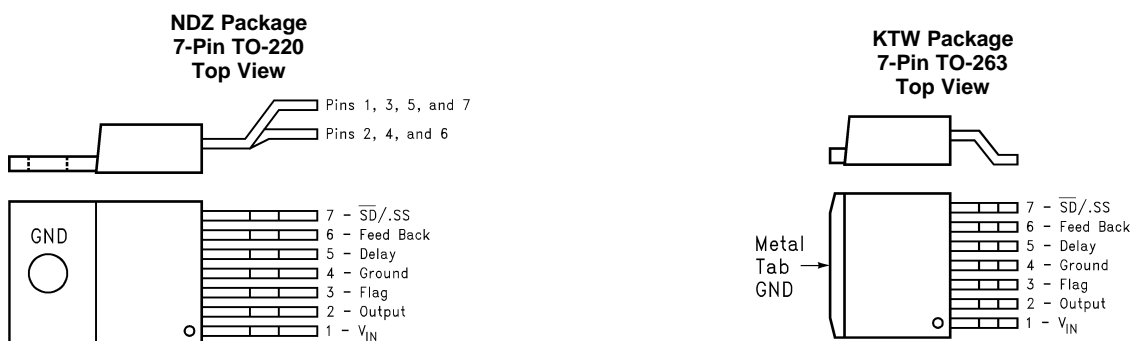

Pin Functions⁽¹⁾

PIN		I/O	DESCRIPTION
NO.	NAME		
1	$+V_{IN}$	I	This is the positive input supply for the IC switching regulator. A suitable input bypass capacitor must be present at this pin to minimize voltage transients and to supply the switching currents needed by the regulator.
2	Output	O	Internal switch. The voltage at this pin switches between approximately $(+V_{IN} - V_{SAT})$ and approximately -0.5 V, with a duty cycle of V_{OUT}/V_{IN} . To minimize coupling to sensitive circuitry, the PCB copper area connected to this pin must be kept to a minimum.
3	Error Flag	O	Open-collector output that provides a low signal (flag transistor ON) when the regulated output voltage drops more than 5% from the nominal output voltage. On start up, Error Flag is low until V_{OUT} reaches 95% of the nominal output voltage and a delay time determined by the Delay pin capacitor. This signal can be used as a reset to a microprocessor on power-up.
4	Ground	—	Circuit ground.
5	Delay	O	At power-up, this pin can be used to provide a time delay between the time the regulated output voltage reaches 95% of the nominal output voltage, and the time the error flag output goes high.
6	Feedback	I	Senses the regulated output voltage to complete the feedback loop.
7	$\overline{Shutdown}/Soft-start$	I	This dual function pin provides the following features: (a) Allows the switching regulator circuit to be shut down using logic level signals thus dropping the total input supply current to approximately 80 μ A. (b) Adding a capacitor to this pin provides a soft-start feature which minimizes start-up current and provides a controlled ramp up of the output voltage.

(1) If any of the above three features ($\overline{Shutdown}/Soft-start$, Error Flag, or Delay) are not used, the respective pins must be left open.

7 Specifications

7.1 Absolute Maximum Ratings ⁽¹⁾⁽²⁾

		MIN	MAX	UNIT
Maximum supply voltage, V_{IN}			45	V
\overline{SD}/SS pin input voltage ⁽³⁾			6	V
Delay pin voltage ⁽³⁾			1.5	V
Flag pin voltage		-0.3	45	V
Feedback pin voltage		-0.3	25	V
Output voltage to ground (steady-state)			-1	V
Power dissipation		Internally limited		
Lead temperature	KTW package	Vapor phase (60 s)		°C
		Infrared (10 s)		
	NDZ package (soldering, 10 s)		260	
Maximum junction temperature			150	°C
Storage temperature, T_{stg}		-65	150	°C

- (1) Stresses beyond those listed under *Absolute Maximum Ratings* may cause permanent damage to the device. These are stress ratings only, which do not imply functional operation of the device at these or any other conditions beyond those indicated under *Recommended Operating Conditions*. Exposure to absolute-maximum-rated conditions for extended periods may affect device reliability.
- (2) If Military/Aerospace specified devices are required, please contact the Texas Instruments Sales Office/Distributors for availability and specifications.
- (3) Voltage internally clamped. If clamp voltage is exceeded, limit current to a maximum of 1 mA.

7.2 ESD Ratings

			VALUE	UNIT
$V_{(ESD)}$	Electrostatic discharge	Human-body model (HBM), per ANSI/ESDA/JEDEC JS-001 ⁽¹⁾	±2000	V

- (1) JEDEC document JEP155 states that 500-V HBM allows safe manufacturing with a standard ESD control process.

7.3 Recommended Operating Conditions

		MIN	MAX	UNIT
Supply voltage		4.5	40	V
Temperature		-40	125	°C

7.4 Thermal Information

THERMAL METRIC ⁽¹⁾		LM2599		UNIT
		KTW (TO-263)	NDZ (TO-220)	
		7 PINS	7 PINS	
$R_{\theta JA}$	Junction-to-ambient thermal resistance ⁽²⁾⁽³⁾	See ⁽⁴⁾	50	°C/W
		See ⁽⁵⁾	—	
		See ⁽⁶⁾	—	
		See ⁽⁷⁾	—	
$R_{\theta JC(top)}$	Junction-to-case (top) thermal resistance	2	2	°C/W

- (1) For more information about traditional and new thermal metrics, see the *Semiconductor and IC Package Thermal Metrics* application report, [SPRA953](#).
- (2) The package thermal impedance is calculated in accordance to JESD 51-7.
- (3) Thermal resistances were simulated on a 4-layer, JEDEC board.
- (4) Junction to ambient thermal resistance (no external heat sink) for the package mounted TO-220 package mounted vertically, with the leads soldered to a PCB with 1-oz copper area of approximately 1 in².
- (5) Junction to ambient thermal resistance with the TO-263 package tab soldered to a single-sided PCB with 0.5 in² of 1-oz copper area.
- (6) Junction to ambient thermal resistance with the TO-263 package tab soldered to a single-sided PCB with 2.5 in² of 1-oz copper area.
- (7) Junction to ambient thermal resistance with the TO-263 package tab soldered to a double-sided PCB with 3 in² of 1-oz copper area on the LM2599S side of the board, and approximately 16 in² of copper on the other side of the PCB.

7.5 Electrical Characteristics – 3.3-V Version

Specifications are for $T_J = 25^\circ\text{C}$ (unless otherwise noted).

PARAMETER	TEST CONDITIONS	MIN ⁽¹⁾	TYP ⁽²⁾	MAX ⁽¹⁾	UNIT	
SYSTEM PARAMETERS⁽³⁾ (see Figure 43 for test circuit)						
V_{OUT} Output voltage	$4.75\text{ V} \leq V_{\text{IN}} \leq 40\text{ V}$, $0.2\text{ A} \leq I_{\text{LOAD}} \leq 3\text{ A}$	$T_J = 25^\circ\text{C}$	3.168	3.3	3.432	V
		$-40^\circ\text{C} \leq T_J \leq 125^\circ\text{C}$	3.135		3.465	
η Efficiency	$V_{\text{IN}} = 12\text{ V}$, $I_{\text{LOAD}} = 3\text{ A}$		73%			

- (1) All room temperature limits are 100% production tested. All limits at temperature extremes are specified via correlation using standard Statistical Quality Control (SQC) methods. All limits are used to calculate Average Outgoing Quality Level (AOQL).
- (2) Typical numbers are at 25°C and represent the most likely norm.
- (3) External components such as the catch diode, inductor, input and output capacitors can affect switching regulator system performance. When the LM2599 is used as shown in Figure 43, system performance is shown in the test conditions column.

7.6 Electrical Characteristics – 5-V Version

Specifications are for $T_J = 25^\circ\text{C}$ (unless otherwise noted).

PARAMETER	TEST CONDITIONS	MIN ⁽¹⁾	TYP ⁽²⁾	MAX ⁽¹⁾	UNIT	
SYSTEM PARAMETERS⁽³⁾ (see Figure 43 for test circuit)						
V_{OUT} Output voltage	$7\text{ V} \leq V_{\text{IN}} \leq 40\text{ V}$, $0.2\text{ A} \leq I_{\text{LOAD}} \leq 3\text{ A}$	$T_J = 25^\circ\text{C}$	4.8	5	5.2	V
		$-40^\circ\text{C} \leq T_J \leq 125^\circ\text{C}$	4.75		5.25	
η Efficiency	$V_{\text{IN}} = 12\text{ V}$, $I_{\text{LOAD}} = 3\text{ A}$		80%			

- (1) All room temperature limits are 100% production tested. All limits at temperature extremes are specified via correlation using standard Statistical Quality Control (SQC) methods. All limits are used to calculate Average Outgoing Quality Level (AOQL).
- (2) Typical numbers are at 25°C and represent the most likely norm.
- (3) External components such as the catch diode, inductor, input and output capacitors can affect switching regulator system performance. When the LM2599 is used as shown in Figure 43, system performance is shown in the test conditions column.

7.7 Electrical Characteristics – 12-V Version

Specifications are for $T_J = 25^\circ\text{C}$ (unless otherwise noted).

PARAMETER	TEST CONDITIONS	MIN ⁽¹⁾	TYP ⁽²⁾	MAX ⁽¹⁾	UNIT	
SYSTEM PARAMETERS⁽³⁾ (see Figure 43 for test circuit)						
V_{OUT} Output voltage	$15\text{ V} \leq V_{\text{IN}} \leq 40\text{ V}$, $0.2\text{ A} \leq I_{\text{LOAD}} \leq 3\text{ A}$	$T_J = 25^\circ\text{C}$	11.52	12	12.48	V
		$-40^\circ\text{C} \leq T_J \leq 125^\circ\text{C}$	11.4		12.6	
η Efficiency	$V_{\text{IN}} = 25\text{ V}$, $I_{\text{LOAD}} = 3\text{ A}$		90%			

- (1) All room temperature limits are 100% production tested. All limits at temperature extremes are specified via correlation using standard Statistical Quality Control (SQC) methods. All limits are used to calculate Average Outgoing Quality Level (AOQL).
- (2) Typical numbers are at 25°C and represent the most likely norm.
- (3) External components such as the catch diode, inductor, input and output capacitors can affect switching regulator system performance. When the LM2599 is used as shown in Figure 43, system performance is shown in the test conditions column.

7.8 Electrical Characteristics – Adjustable Voltage Version

Specifications are for $T_J = 25^\circ\text{C}$ (unless otherwise noted).

PARAMETER	TEST CONDITIONS	MIN ⁽¹⁾	TYP ⁽²⁾	MAX ⁽¹⁾	UNIT
SYSTEM PARAMETERS⁽³⁾ (see Figure 43 for test circuit)					
V_{FB} Feedback voltage	$4.5\text{ V} \leq V_{\text{IN}} \leq 40\text{ V}$, $0.2\text{ A} \leq I_{\text{LOAD}} \leq 3\text{ A}$ V_{OUT} programmed for 3 V, circuit of Figure 43		1.23		V
		$T_J = 25^\circ\text{C}$	1.193	1.267	
		$-40^\circ\text{C} \leq T_J \leq 125^\circ\text{C}$	1.18	1.28	
η Efficiency	$V_{\text{IN}} = 12\text{ V}$, $V_{\text{OUT}} = 3\text{ V}$, $I_{\text{LOAD}} = 3\text{ A}$		73%		

- (1) All room temperature limits are 100% production tested. All limits at temperature extremes are specified via correlation using standard Statistical Quality Control (SQC) methods. All limits are used to calculate Average Outgoing Quality Level (AOQL).
- (2) Typical numbers are at 25°C and represent the most likely norm.
- (3) External components such as the catch diode, inductor, input and output capacitors can affect switching regulator system performance. When the LM2599 is used as shown in Figure 43, system performance is shown in the test conditions column.

7.9 Electrical Characteristics – All Output Voltage Versions

Specifications are for $T_J = 25^\circ\text{C}$, $I_{\text{LOAD}} = 500\text{ mA}$, $V_{\text{IN}} = 12\text{ V}$ for the 3.3-V, 5-V, and Adjustable version, and $V_{\text{IN}} = 24\text{ V}$ for the 12-V version (unless otherwise noted).

PARAMETER		TEST CONDITIONS	MIN ⁽¹⁾	TYP ⁽²⁾	MAX ⁽¹⁾	UNIT	
DEVICE PARAMETERS							
I_b	Feedback bias current	Adjustable voltage version only, $V_{\text{FB}} = 1.3\text{ V}$	$T_J = 25^\circ\text{C}$	10	50	nA	
			$-40^\circ\text{C} \leq T_J \leq 125^\circ\text{C}$		100		
f_o	Oscillator frequency ⁽³⁾		$T_J = 25^\circ\text{C}$	127	150	173	kHz
			$-40^\circ\text{C} \leq T_J \leq 125^\circ\text{C}$	110		173	
V_{SAT}	Saturation voltage	$I_{\text{OUT}} = 3\text{ A}$ ⁽⁴⁾⁽⁵⁾	$T_J = 25^\circ\text{C}$	1.16	1.4	V	
			$-40^\circ\text{C} \leq T_J \leq 125^\circ\text{C}$		1.5		
DC	Max duty cycle (ON) ⁽⁵⁾			100%			
	Min duty cycle (OFF) ⁽⁶⁾			0%			
I_{CL}	Current limit	Peak current ^{(4) (5)}	$T_J = 25^\circ\text{C}$	3.6	4.5	6.9	A
			$-40^\circ\text{C} \leq T_J \leq 125^\circ\text{C}$	3.4		7.5	
I_L	Output leakage current	Output = 0 V, $V_{\text{IN}} = 40\text{ V}$ ^{(4) (6)}			50	μA	
		Output = -1 V		2	30	mA	
I_Q	Operating quiescent current	$\overline{\text{SD}}/\overline{\text{SS}}$ pin open ⁽⁶⁾		5	10	mA	
I_{STBY}	Current standby quiescent	$\overline{\text{SD}}/\overline{\text{SS}}$ pin = 0 V, $V_{\text{IN}} = 40\text{ V}$	$T_J = 25^\circ\text{C}$	80	200	μA	
			$-40^\circ\text{C} \leq T_J \leq 125^\circ\text{C}$		250	μA	
SHUTDOWN/SOFT-START CONTROL – See Figure 43							
V_{SD}	Shutdown threshold voltage			1.3		V	
		Low (Shutdown mode), $-40^\circ\text{C} \leq T_J \leq 125^\circ\text{C}$			0.6		
		High (Soft-start mode), $-40^\circ\text{C} \leq T_J \leq 125^\circ\text{C}$	2				
V_{SS}	Soft-start voltage	$V_{\text{OUT}} = 20\%$ of nominal output voltage		2		V	
		$V_{\text{OUT}} = 100\%$ of nominal output voltage		3			
I_{SD}	Shutdown current	$V_{\text{SHUTDOWN}} = 0.5\text{ V}$		5	10	μA	
I_{SS}	Soft-start current	$V_{\text{Soft-start}} = 2.5\text{ V}$		1.6	5	μA	
FLAG/DELAY CONTROL – See Figure 43							
	Regulator dropout detector threshold voltage	Low (flag ON)		92%	96%	98%	
V_{FSAT}	Voltage flag output saturation	$I_{\text{SINK}} = 3\text{ mA}$	$T_J = 25^\circ\text{C}$			0.3	V
				$V_{\text{DELAY}} = 0.5\text{ V}$	$-40^\circ\text{C} \leq T_J \leq 125^\circ\text{C}$	0.7	
						1	
I_{FL}	Flag output leakage current	$V_{\text{FLAG}} = 40\text{ V}$		0.3		μA	
	Voltage delay pin threshold					1.25	V
				Low (flag ON)	1.21		
				High (flag OFF) and V_{OUT} regulated	1.29		
	Delay pin source current	$V_{\text{DELAY}} = 0.5\text{ V}$		3	6	μA	
	Delay pin saturation	Low (flag ON)	$T_J = 25^\circ\text{C}$	55	350	mV	
			$-40^\circ\text{C} \leq T_J \leq 125^\circ\text{C}$		400		

- (1) All room temperature limits are 100% production tested. All limits at temperature extremes are specified via correlation using standard Statistical Quality Control (SQC) methods. All limits are used to calculate Average Outgoing Quality Level (AOQL).
- (2) Typical numbers are at 25°C and represent the most likely norm.
- (3) The switching frequency is reduced when the second stage current limit is activated. The amount of reduction is determined by the severity of current overload.
- (4) No diode, inductor or capacitor connected to output pin.
- (5) Feedback pin removed from output and connected to 0 V to force the output transistor switch ON.
- (6) Feedback pin removed from output and connected to 12 V for the 3.3-V, 5-V, and the adjustable versions, and 15 V for the 12-V version, to force the output transistor switch OFF.

7.10 Typical Characteristics

See Figure 43 for test circuit

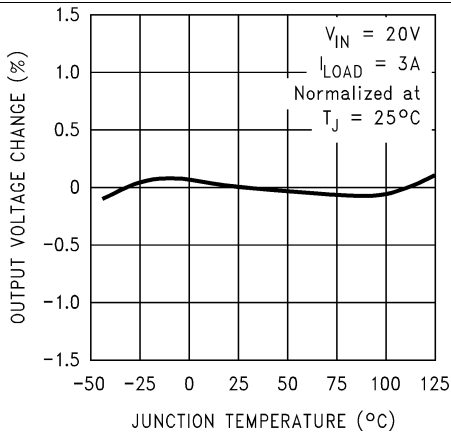

Figure 1. Normalized Output Voltage

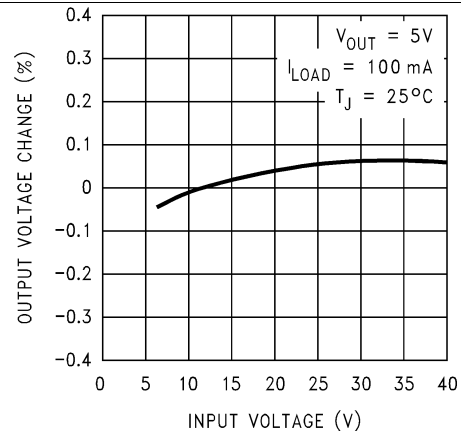

Figure 2. Line Regulation

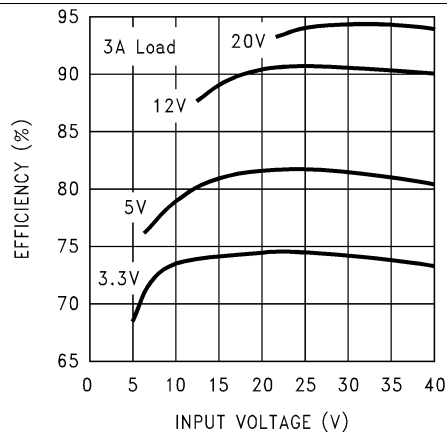

Figure 3. Efficiency

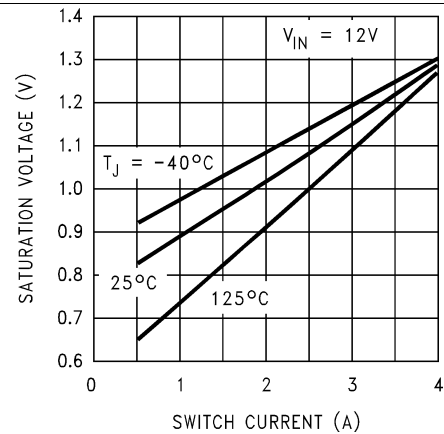

Figure 4. Switch Saturation Voltage

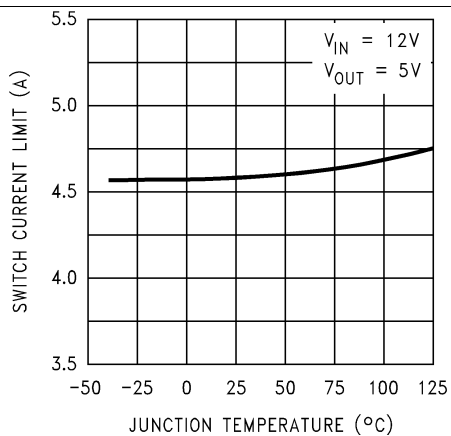

Figure 5. Switch Current Limit

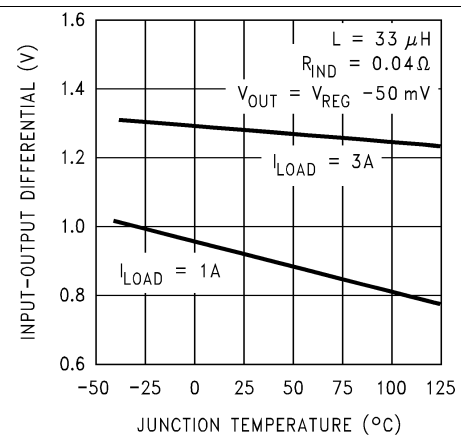

Figure 6. Dropout Voltage

Typical Characteristics (continued)

See Figure 43 for test circuit

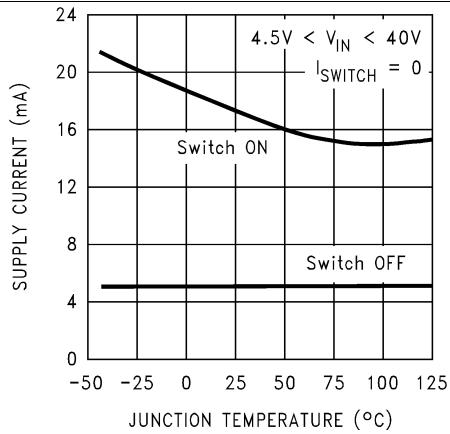

Figure 7. Operating Quiescent Current

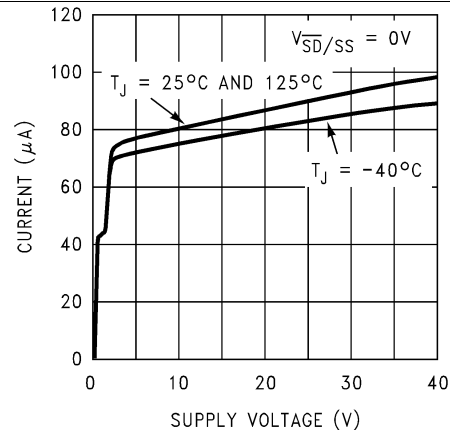

Figure 8. Shutdown Quiescent Current

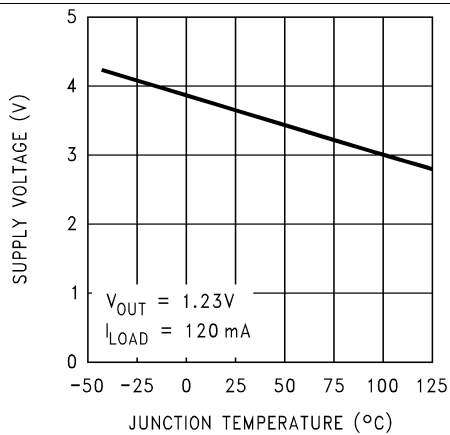

Figure 9. Minimum Operating Supply Voltage

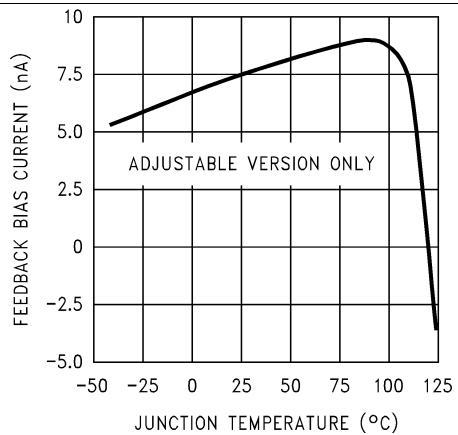

Figure 10. Feedback Pin Bias Current

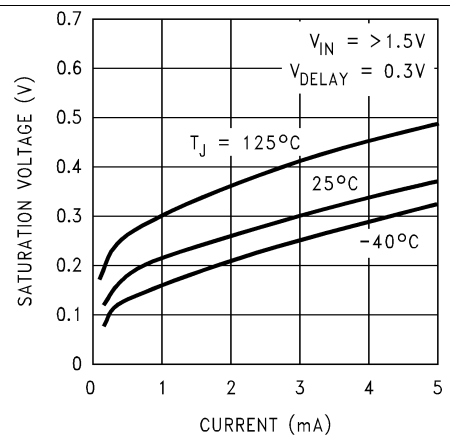

Figure 11. Flag Saturation Voltage

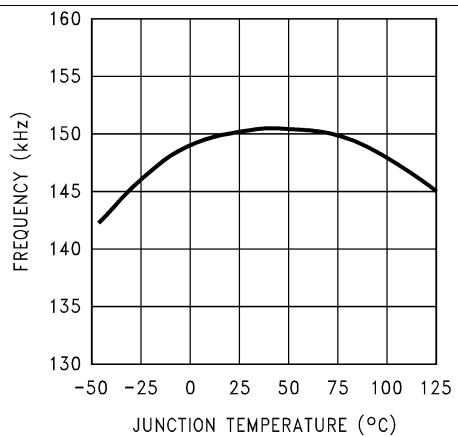

Figure 12. Switching Frequency

Typical Characteristics (continued)

See Figure 43 for test circuit

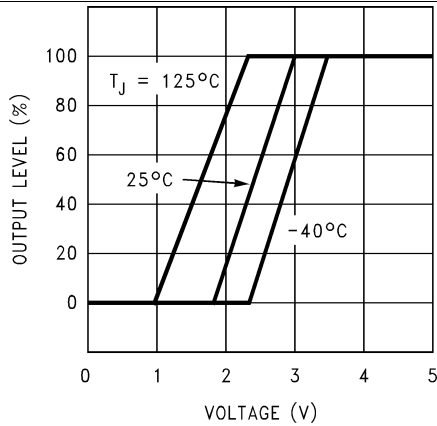

Figure 13. Soft-Start

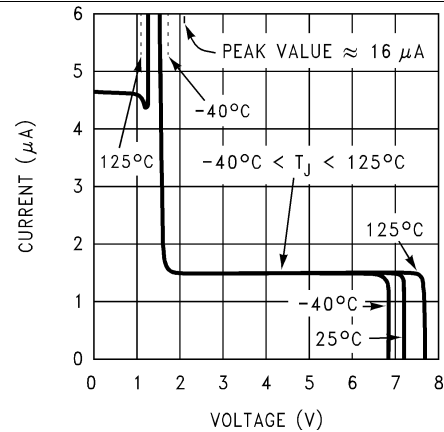

Figure 14. Shutdown/Soft-Start Current

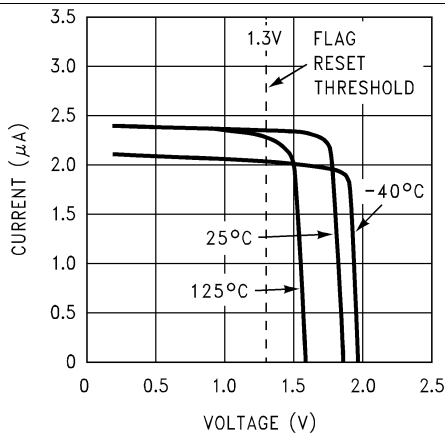

Figure 15. Daisy Pin Current

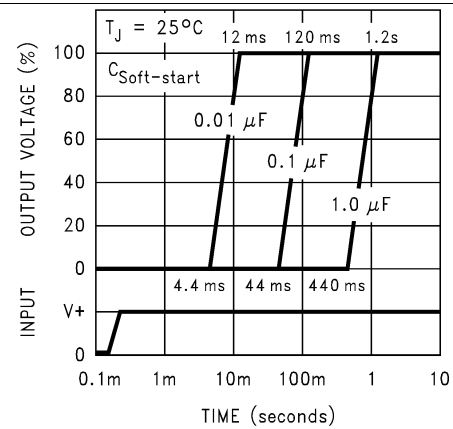

Figure 16. Soft-Start Response

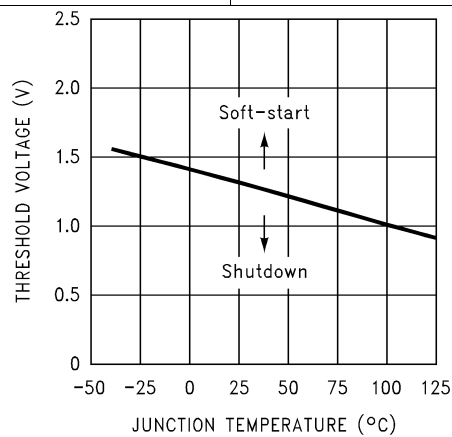

Figure 17. Shutdown/Soft-Start Threshold Voltage

8 Detailed Description

8.1 Overview

The LM2599 SIMPLE SWITCHER[®] regulator is an easy-to-use, nonsynchronous, step-down DC-DC converter with a wide input voltage range up to 40 V. The regulator is capable of delivering up to 3-A DC load current with excellent line and load regulation. These devices are available in fixed output voltages of 3.3 V, 5 V, 12 V, and an adjustable output version. The family requires few external components, and the pin arrangement was designed for simple, optimum PCB layout.

8.2 Functional Block Diagram

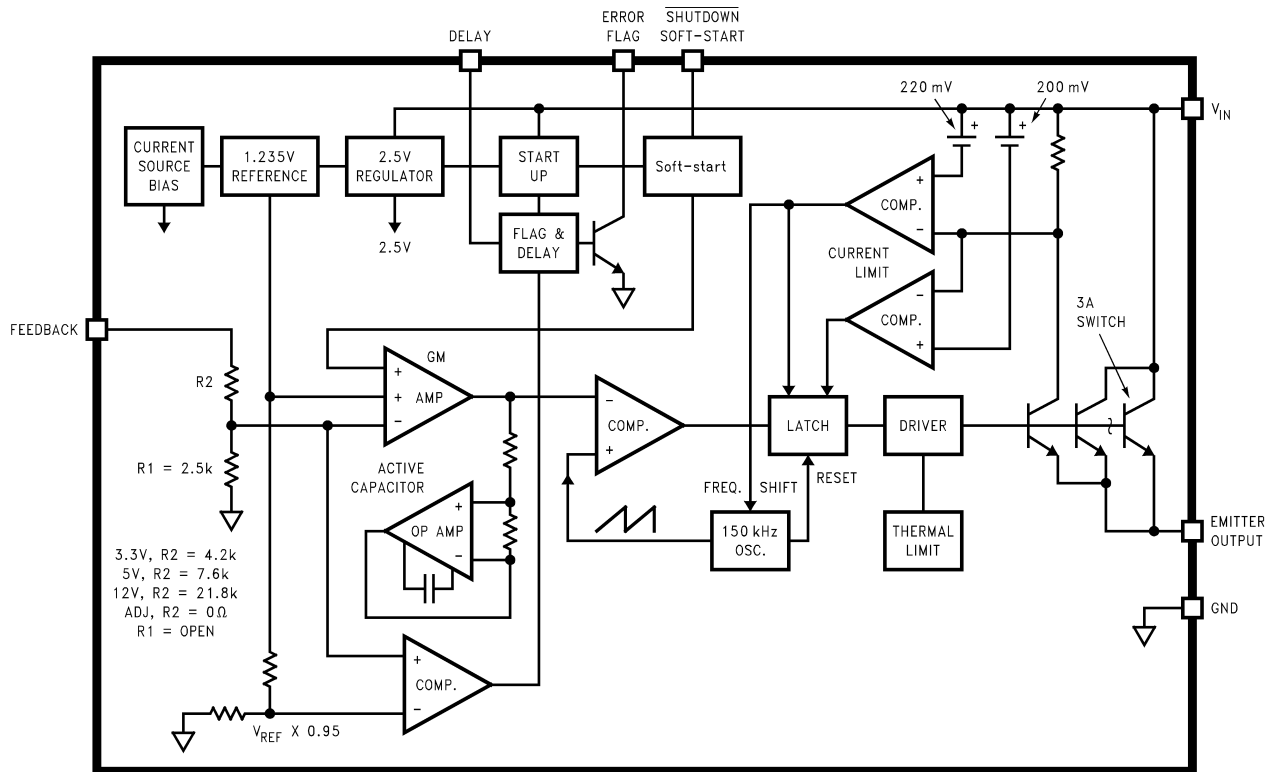

8.3 Feature Description

8.3.1 Shutdown/Soft-Start

The circuit shown in Figure 20 is a standard buck regulator with $20-V_{IN}$, $12-V_{OUT}$, 1-A load using a 0.068- μ F soft-start capacitor. Figure 18 and Figure 19 show the effects of soft-start on the output voltage, the input current, with, and without a soft-start capacitor. The reduced input current required at startup is very evident when comparing the two photos. The soft-start feature reduces the start-up current from 2.6 A down to 650 mA, and delays and slows down the output voltage rise time.

Feature Description (continued)

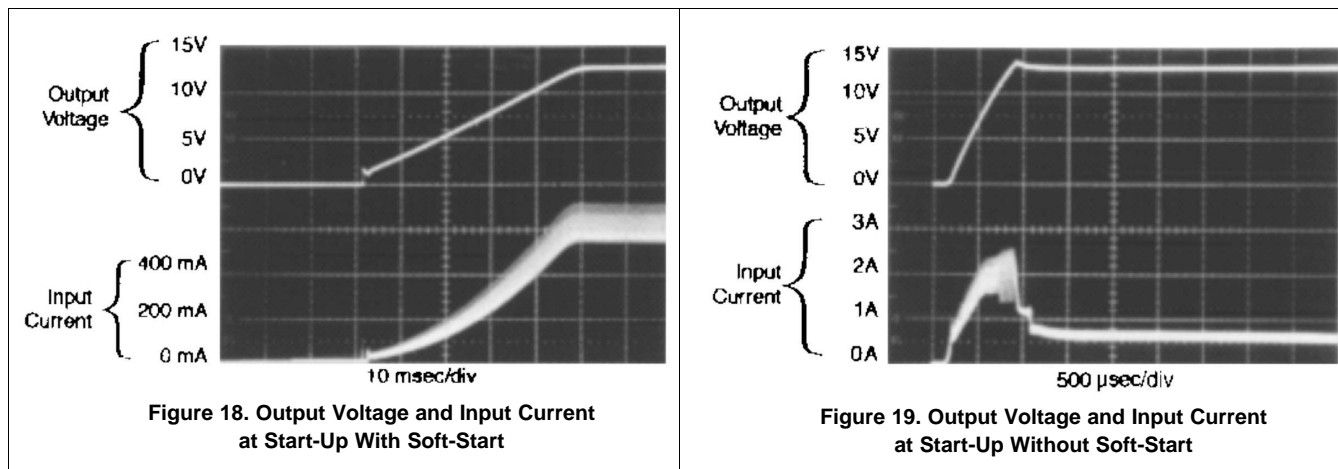

This reduction in start-up current is useful in situations where the input power source is limited in the amount of current it can deliver. In some applications soft-start can be used to replace undervoltage lockout or delayed start-up functions.

If a very slow output voltage ramp is desired, the soft-start capacitor can be made much larger. Many seconds or even minutes are possible.

If only the shutdown feature is needed, the soft-start capacitor can be eliminated.

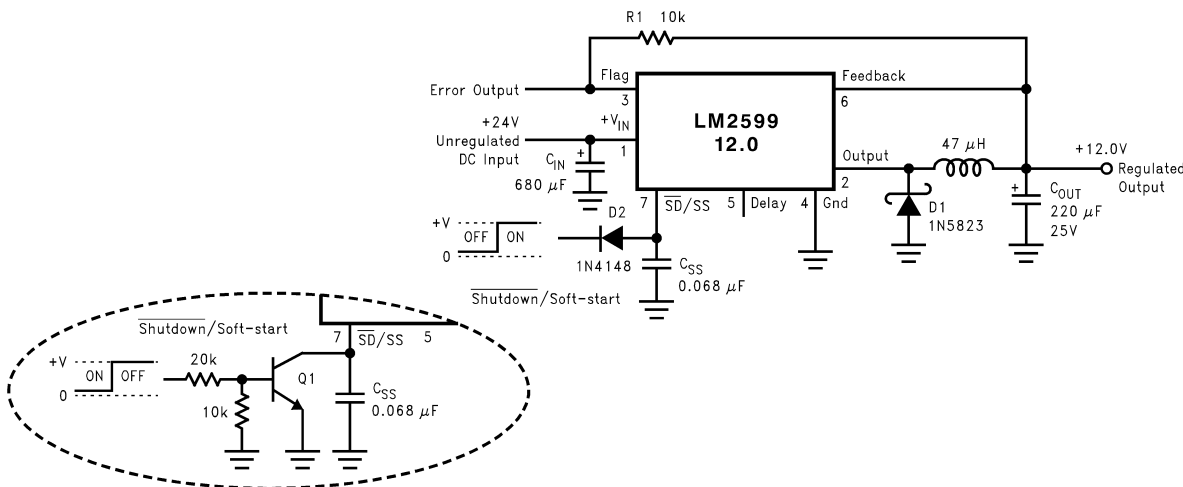

Feature Description (continued)

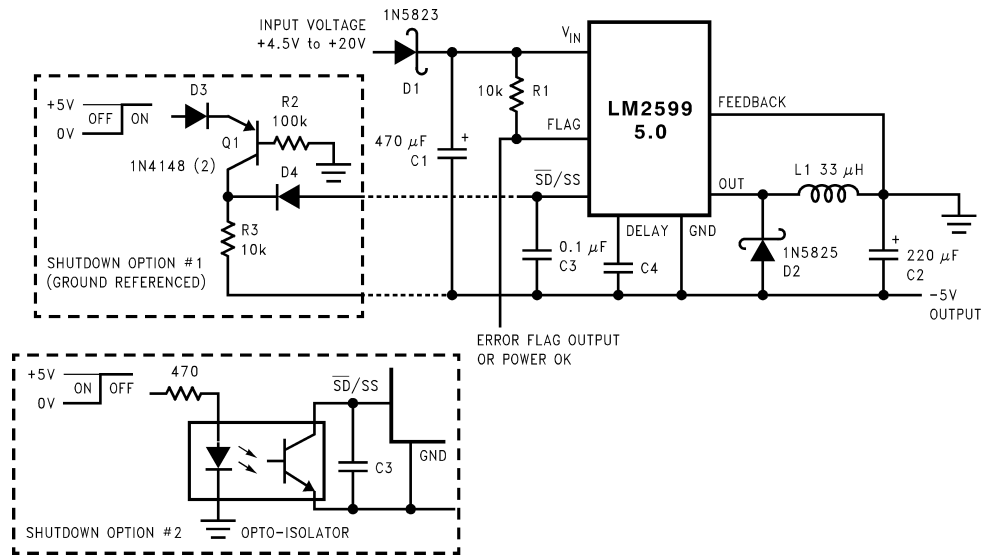

Figure 21. Inverting -5-V Regulator With Shutdown and Soft-Start

8.3.2 Inverting Regulator

The circuit in Figure 21 converts a positive input voltage to a negative output voltage with a common ground. The circuit operates by bootstrapping the ground pin of the regulator to the negative output voltage, then grounding the feedback pin, the regulator senses the inverted output voltage and regulates it.

This example uses the LM2599-5 to generate a -5-V output, but other output voltages are possible by selecting other output voltage versions, including the adjustable version. Because this regulator topology can produce an output voltage that is either greater than or less than the input voltage, the maximum output current greatly depends on both the input and output voltage. The curve shown in Figure 22 provides a guide as to the amount of output load current possible for the different input and output voltage conditions.

The maximum voltage appearing across the regulator is the absolute sum of the input and output voltage, and this must be limited to a maximum of 40 V. In this example, when converting 20 V to -5 V, the regulator would see 25 V between the input pin and ground pin. The LM2599 has a maximum input voltage rating of 40 V.

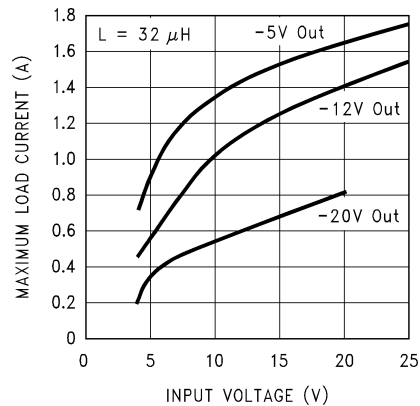

Figure 22. Maximum Load Current for Inverting Regulator Circuit

Feature Description (continued)

An additional diode is required in this regulator configuration. Diode D1 is used to isolate input voltage ripple or noise from coupling through the C_{IN} capacitor to the output, under light or no load conditions. Also, this diode isolation changes the topology to closely resemble a buck configuration, thus providing good closed-loop stability. TI recommends a Schottky diode for low input voltages, (because of its lower voltage drop) but for higher input voltages, a 1N5400 diode could be used.

Because of differences in the operation of the inverting regulator, the standard design procedure is not used to select the inductor value. In the majority of designs, a 33- μ H, 3.5-A inductor is the best choice. Capacitor selection can also be narrowed down to just a few values. Using the values shown in Figure 21 provides good results in the majority of inverting designs.

This type of inverting regulator can require relatively large amounts of input current when starting up, even with light loads. Input currents as high as the LM2599 current limit (approximately 4.5 A) are needed for 2 ms or more, until the output reaches its nominal output voltage. The actual time depends on the output voltage and the size of the output capacitor. Input power sources that are current limited or sources that can not deliver these currents without getting loaded down, may not work correctly. Because of the relatively high startup currents required by the inverting topology, the soft-start feature shown in Figure 21 is recommended.

Also shown in Figure 21 are several shutdown methods for the inverting configuration. With the inverting configuration, some level shifting is required, because the ground pin of the regulator is no longer at ground, but is now at the negative output voltage. The shutdown methods shown accept ground referenced shutdown signals.

8.3.3 Undervoltage Lockout

Some applications require the regulator to remain off until the input voltage reaches a predetermined voltage. Figure 23 contains an undervoltage lockout circuit for a buck configuration, while Figure 24 and Figure 25 are for the inverting types (only the circuitry pertaining to the undervoltage lockout is shown). Figure 23 uses a Zener diode to establish the threshold voltage when the switcher begins operating. When the input voltage is less than the Zener voltage, resistors R1 and R2 hold the shutdown/soft-start pin low, keeping the regulator in the shutdown mode. As the input voltage exceeds the Zener voltage, the Zener conducts, pulling the shutdown/soft-start pin high, allowing the regulator to begin switching. The threshold voltage for the undervoltage lockout feature is approximately 1.5 V greater than the Zener voltage.

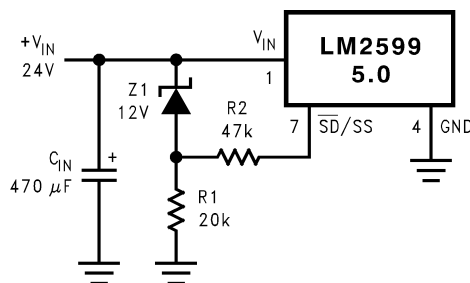

Figure 23. Undervoltage Lockout for a Buck Regulator

Figure 24 and Figure 25 apply the same feature to an inverting circuit. Figure 24 features a constant threshold voltage for turn on and turn off (Zener voltage plus approximately one volt). If hysteresis is needed, the circuit in Figure 25 has a turn ON voltage which is different than the turn OFF voltage. The amount of hysteresis is approximately equal to the value of the output voltage. Because the $\overline{SD/SS}$ pin has an internal 7-V Zener clamp, R2 is needed to limit the current into this pin to approximately 1 mA when Q1 is on.

Feature Description (continued)

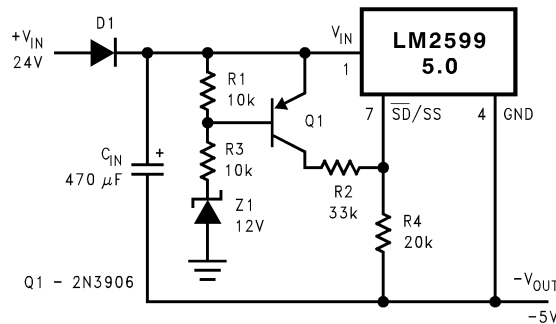

Figure 24. Undervoltage Lockout Without Hysteresis for an Inverting Regulator

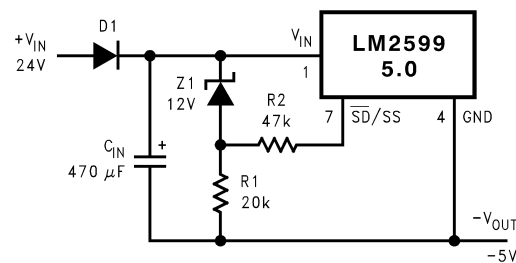

Figure 25. Undervoltage Lockout With Hysteresis for an Inverting Regulator

8.3.4 Negative Voltage Charge Pump

Occasionally a low-current negative voltage is needed for biasing parts of a circuit. A simple method of generating a negative voltage using a charge pump technique and the switching waveform present at the OUT pin, is shown in Figure 26. This unregulated negative voltage is approximately equal to the positive input voltage (minus a few volts), and can supply up to a 600 mA of output current. There is a requirement however, that there be a minimum load of 1.2 A on the regulated positive output for the charge pump to work correctly. Also, resistor R1 is required to limit the charging current of C1 to some value less than the LM2599 current limit (typically 4.5 A).

This method of generating a negative output voltage without an additional inductor can be used with other members of the SIMPLE SWITCHER Family, using either the buck or boost topology.

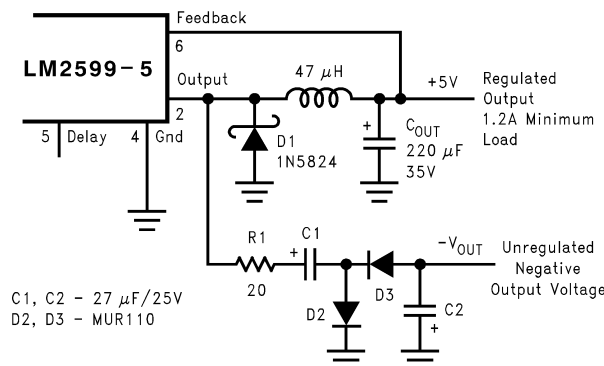

Figure 26. Charge Pump for Generating a Low-Current, Negative-Output Voltage

8.4 Device Functional Modes

8.4.1 Discontinuous Mode Operation

The selection guide chooses inductor values suitable for continuous mode operation, but for low current applications or high input voltages, a discontinuous mode design may be a better choice. The design would use an inductor that would be physically smaller, and would need only one half to one third the inductance value needed for a continuous mode design. The peak switch and inductor currents is higher in a discontinuous design, but at these low load currents (1 A and below), the maximum switch current is still less than the switch current limit.

Discontinuous operation can have voltage waveforms that are considerably different than a continuous design. The output pin (switch) waveform can have some damped sinusoidal ringing present (see [Figure 44](#)). This ringing is normal for discontinuous operation, and is not caused by feedback loop instabilities. In discontinuous operation, there is a period of time where neither the switch nor the diode are conducting, and the inductor current has dropped to zero. During this time, a small amount of energy can circulate between the inductor and the switch and diode parasitic capacitance causing this characteristic ringing. Normally this ringing is not a problem, unless the amplitude becomes great enough to exceed the input voltage, and even then, there is very little energy present to cause damage.

Different inductor types or core materials produce different amounts of this characteristic ringing. Ferrite core inductors have very little core loss and therefore produce the most ringing. The higher core loss of powdered iron inductors produce less ringing. If desired, a series RC could be placed in parallel with the inductor to dampen the ringing.

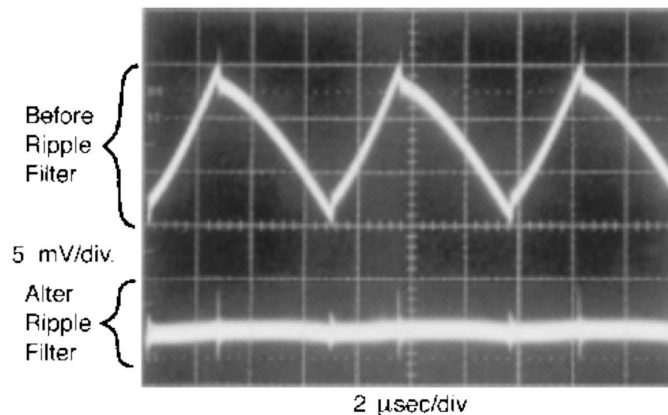

Figure 27. Post Ripple Filter Waveform

9 Application and Implementation

NOTE

Information in the following applications sections is not part of the TI component specification, and TI does not warrant its accuracy or completeness. TI's customers are responsible for determining suitability of components for their purposes. Customers should validate and test their design implementation to confirm system functionality.

9.1 Application Information

9.1.1 Soft-Start Capacitor (C_{SS})

The capacitor on this pin provides the regulator with a soft-start feature (slow start-up). When the DC input voltage is first applied to the regulator, or when the Shutdown/Soft-start pin is allowed to go high, a constant current (approximately 5 μ A) begins charging this capacitor). As the capacitor voltage rises, the regulator goes through four operating regions (see the bottom curve in [Figure 28](#)):

1. Regulator in Shutdown: When the $\overline{SD/SS}$ pin voltage is between 0 V and 1.3 V, the regulator is in shutdown, the output voltage is zero, and the IC quiescent current is approximately 85 μ A.
2. Regulator ON, but the output voltage is zero: With the $\overline{SD/SS}$ pin voltage between approximately 1.3 V and 1.8 V, the internal regulator circuitry is operating, the quiescent current rises to approximately 5 mA, but the output voltage is still zero. Also, as the 1.3-V threshold is exceeded, the soft-start capacitor charging current decreases from 5 μ A down to approximately 1.6 μ A. This decreases the slope of capacitor voltage ramp.
3. Soft-start Region: When the $\overline{SD/SS}$ pin voltage is between 1.8 V and 2.8 V (at 25°C), the regulator is in a soft-start condition. The switch (Pin 2) duty cycle initially starts out very low, with narrow pulses and gradually get wider as the capacitor $\overline{SD/SS}$ pin ramps up towards 2.8 V. As the duty cycle increases, the output voltage also increases at a controlled ramp up (see the center curve in [Figure 28](#)) The input supply current requirement also starts out at a low level for the narrow pulses and ramp up in a controlled manner. This is a very useful feature in some switcher topologies that require large start-up currents (such as the inverting configuration) which can load down the input power supply.

NOTE

The lower curve shown in [Figure 28](#) shows the soft-start region from 0% to 100%. This is not the duty cycle percentage, but the output voltage percentage. Also, the soft-start voltage range has a negative temperature coefficient associated with it. See the soft-start section in [Electrical Characteristics – All Output Voltage Versions](#).

4. Normal operation: Above 2.8 V, the circuit operates as a standard Pulse Width Modulated switching regulator. The capacitor continues to charge up until it reaches the internal clamp voltage of approximately 7 V. If this pin is driven from a voltage source, the current must be limited to about 1 mA.

If the part is operated with an input voltage at or below the internal soft-start clamp voltage of approximately 7 V, the voltage on the SD/SS pin tracks the input voltage and can be disturbed by a step in the voltage. To maintain proper function under these conditions, TI strongly recommends clamping the SD/SS pin externally between the 3-V maximum soft-start threshold and the 4.5-V minimum input voltage. [Figure 30](#) is an example of an external 3.7-V (approximately) clamp that prevents a line-step related glitch but does not interfere with the soft-start behavior of the device.

Application Information (continued)

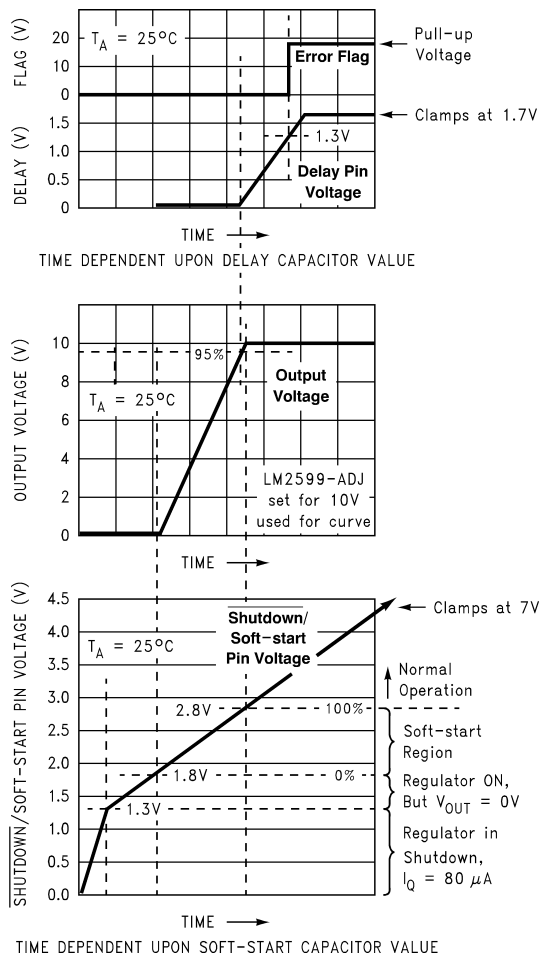

Figure 28. Soft-Start, Delay, Error, Output

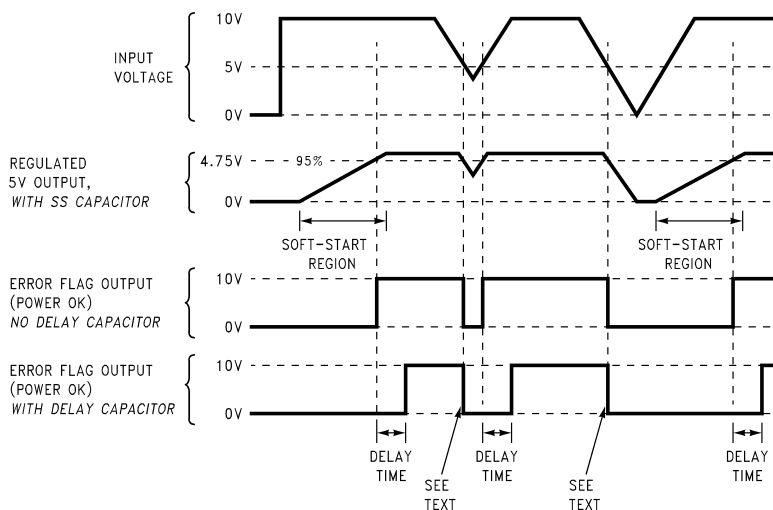

Figure 29. Timing Diagram for 5-V Output

Application Information (continued)

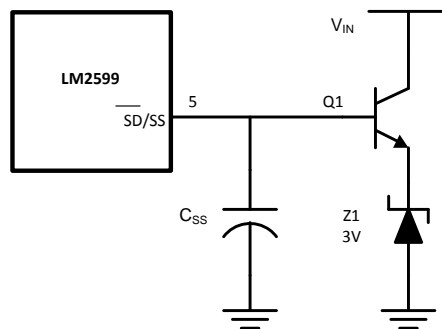

Figure 30. External 3.7-V Soft-Start Clamp

9.1.2 Delay Capacitor (C_{DELAY})

This capacitor provides delay for the error flag output (see [Figure 28](#) and [Figure 29](#)). A capacitor on this pin provides a time delay between the time the regulated output voltage (when it is increasing in value) reaches 95% of the nominal output voltage, and the time the error flag output goes high. A 3- μA constant current from the delay pin charges the delay capacitor resulting in a voltage ramp. When this voltage reaches a threshold of approximately 1.3 V, the open-collector error flag output (or power OK) goes high. This signal can be used to indicate that the regulated output has reached the correct voltage and has stabilized.

If, for any reason, the regulated output voltage drops by 5% or more, the error output flag (Pin 3) immediately goes low (internal transistor turns on). The delay capacitor provides very little delay if the regulated output is dropping out of regulation. The delay time for an output that is decreasing is approximately a 1000 times less than the delay for the rising output. For a 0.1- μF delay capacitor, the delay time would be approximately 50 ms when the output is rising and passes through the 95% threshold, but the delay for the output dropping would only be approximately 50 μs .

9.1.2.1 R_{PULLUP}

The error flag output (or power OK) is the collector of a NPN transistor, with the emitter internally grounded. To use the error flag, a pullup resistor to a positive voltage is needed. The error flag transistor is rated up to a maximum of 45 V and can sink approximately 3 mA. If the error flag is not used, it can be left open.

9.1.3 Feedforward Capacitor (C_{FF}) for Adjustable Output Voltage Version Only

A feedforward capacitor, C_{FF} , is used when the output voltage is greater than 10 V or when C_{OUT} has a very low ESR. This capacitor adds lead compensation to the feedback loop and increases the phase margin for better loop stability.

If the output ripple is large (> 5% of the nominal output voltage), this ripple can be coupled to the feedback pin through the feedforward capacitor and cause the error comparator to trigger the error flag. In this situation, adding a resistor, R_{FF} , in series with the feedforward capacitor, approximately 3 times R_1 , attenuates the ripple voltage at the feedback pin.

9.1.4 Input Capacitor (C_{IN})

A low-ESR aluminum or tantalum bypass capacitor is required between the input pin and ground pin. The capacitor must be placed near the regulator using short leads. This capacitor prevents large voltage transients from appearing at the input, and provides the instantaneous current needed each time the switch turns on.

The important parameters for the Input capacitor are the voltage rating and the RMS current rating. Because of the relatively high RMS currents flowing in a input capacitor of the buck regulator, this capacitor must be chosen for its RMS current rating rather than its capacitance or voltage ratings, although the capacitance value and voltage rating are directly related to the RMS current rating.

Application Information (continued)

The RMS current rating of a capacitor could be viewed as a power rating of the capacitor. The RMS current flowing through the capacitors internal ESR produces power which causes the internal temperature of the capacitor to rise. The RMS current rating of a capacitor is determined by the amount of current required to raise the internal temperature approximately 10°C above an ambient temperature of 105°C. The ability of the capacitor to dissipate this heat to the surrounding air determines the amount of current the capacitor can safely sustain. Capacitors that are physically large and have a large surface area typically has a higher RMS current ratings. For a given capacitor value, a higher voltage electrolytic capacitor is physically larger than a lower voltage capacitor, and thus be able to dissipate more heat to the surrounding air, and therefore has a higher RMS current rating.

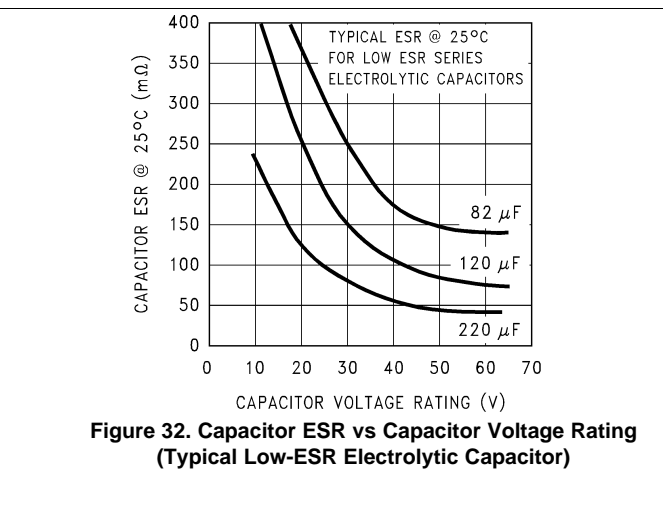
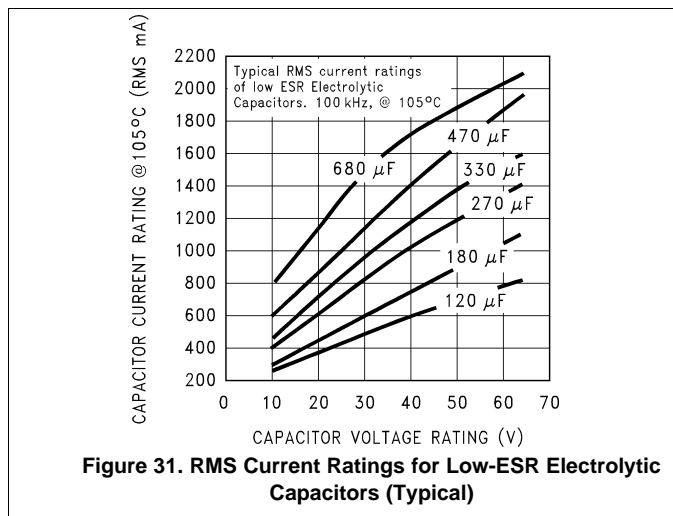

The consequences of operating an electrolytic capacitor above the RMS current rating is a shortened operating life. The higher temperature speeds up the evaporation of the capacitor's electrolyte, resulting in eventual failure.

Selecting an input capacitor requires consulting the manufacturers data sheet for maximum allowable RMS ripple current. For a maximum ambient temperature of 40°C, a general guideline would be to select a capacitor with a ripple current rating of approximately 50% of the DC load current. For ambient temperatures up to 70°C, a current rating of 75% of the DC load current would be a good choice for a conservative design. The capacitor voltage rating must be at least 1.25 times greater than the maximum input voltage, and often a much higher voltage capacitor is needed to satisfy the RMS current requirements.

Figure 31 shows the relationship between an electrolytic capacitor value, its voltage rating, and the RMS current it is rated for. These curves were obtained from the Nichicon PL series of low-ESR, high-reliability electrolytic capacitors designed for switching regulator applications. Other capacitor manufacturers offer similar types of capacitors, but always check the capacitor data sheet.

Standard electrolytic capacitors typically have much higher ESR numbers, lower RMS current ratings and typically have a shorter operating lifetime.

Because of their small size and excellent performance, surface-mount solid tantalum capacitors are often used for input bypassing, but several precautions must be observed. A small percentage of solid tantalum capacitors can short if the inrush current rating is exceeded. This can happen at turnon when the input voltage is suddenly applied, and of course, higher input voltages produce higher inrush currents. Several capacitor manufacturers do a 100% surge current testing on their products to minimize this potential problem. If high turnon currents are expected, it may be necessary to limit this current by adding either some resistance or inductance before the tantalum capacitor, or select a higher voltage capacitor. As with aluminum electrolytic capacitors, the RMS ripple current rating must be sized to the load current.

Application Information (continued)

9.1.5 Output Capacitor (C_{OUT})

An output capacitor is required to filter the output and provide regulator loop stability. Low impedance or low-ESR Electrolytic or solid tantalum capacitors designed for switching regulator applications must be used. When selecting an output capacitor, the important capacitor parameters are; the 100-kHz Equivalent Series Resistance (ESR), the RMS ripple current rating, voltage rating, and capacitance value. For the output capacitor, the ESR value is the most important parameter.

The output capacitor requires an ESR value that has an upper and lower limit. For low output ripple voltage, a low ESR value is needed. This value is determined by the maximum allowable output ripple voltage, typically 1% to 2% of the output voltage. But if the ESR of the selected capacitor is extremely low, there is a possibility of an unstable feedback loop, resulting in an oscillation at the output. Using the capacitors listed in the tables, or similar types, provides design solutions under all conditions.

If very low output ripple voltage (less than 15 mV) is required, see [Output Voltage Ripple and Transients](#) for a post ripple filter.

An aluminum electrolytic capacitor's ESR value is related to the capacitance value and its voltage rating. In most cases, higher voltage electrolytic capacitors have lower ESR values (see [Figure 32](#)). Often, capacitors with much higher voltage ratings may be needed to provide the low ESR values required for low output ripple voltage.

The output capacitor for many different switcher designs often can be satisfied with only three or four different capacitor values and several different voltage ratings. See the quick design component selection tables in [Table 3](#) and [Table 6](#) for typical capacitor values, voltage ratings, and manufacturer capacitor types.

Electrolytic capacitors are not recommended for temperatures below -25°C . The ESR rises dramatically at cold temperatures and typically rises 3X at -25°C and as much as 10X at -40°C (see [Figure 33](#)).

Solid tantalum capacitors have a much better ESR specification for cold temperatures and are recommended for temperatures below -25°C .

9.1.6 Catch Diode

Buck regulators require a diode to provide a return path for the inductor current when the switch turns off. This must be a fast diode and must be placed close to the LM2599 using short leads and short printed circuit traces.

Because of their very fast switching speed and low forward voltage drop, Schottky diodes provide the best performance, especially in low output voltage applications (5 V and lower). Ultra-fast recovery, or high-efficiency rectifiers are also a good choice, but some types with an abrupt turnoff characteristic may cause instability or EMI problems. Ultra-fast recovery diodes typically have reverse recovery times of 50 ns or less. Rectifiers such as the IN5400 series are much too slow and must not be used.

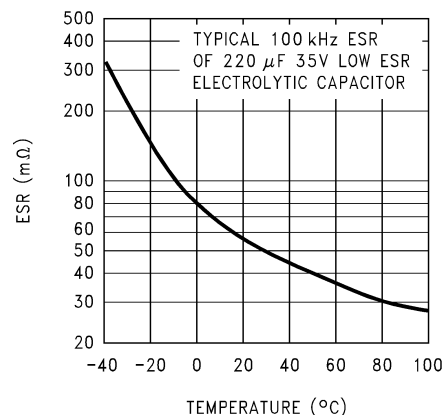

Figure 33. Capacitor ESR Change vs Temperature

Application Information (continued)

9.1.7 Inductor Selection

All switching regulators have two basic modes of operation; continuous and discontinuous. The difference between the two types relates to the inductor current, whether it is flowing continuously, or if it drops to zero for a period of time in the normal switching cycle. Each mode has distinctively different operating characteristics, which can affect the regulators performance and requirements. Most switcher designs operates in the discontinuous mode when the load current is low.

The LM2599 (or any of the SIMPLE SWITCHER family) can be used for both continuous or discontinuous modes of operation.

In many cases the preferred mode of operation is the continuous mode. This mode offers greater output power, lower peak switch, inductor and diode currents, and can have lower output ripple voltage. However, the continuous mode requires larger inductor values to keep the inductor current flowing continuously, especially at low output load currents and/or high input voltages.

To simplify the inductor selection process, an inductor selection guide (nomograph) was designed (see [Figure 35](#) through [Figure 38](#)). This guide assumes that the regulator is operating in the continuous mode, and selects an inductor that allows a peak-to-peak inductor ripple current to be a certain percentage of the maximum design load current. This peak-to-peak inductor ripple current percentage is not fixed, but is allowed to change as different design load currents are selected (see [Figure 34](#)).

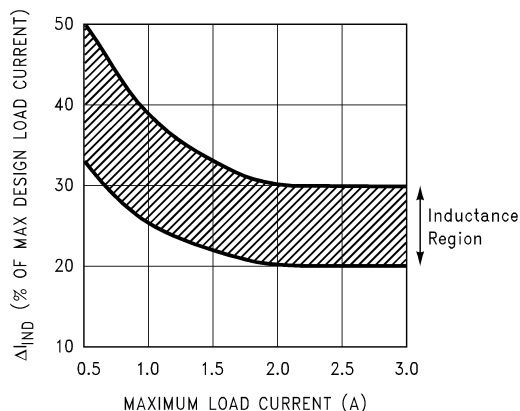

Figure 34. ΔI_{IND} , Peak-to-Peak Inductor Ripple Current (as a Percentage of the Load Current) vs Load Current

By allowing the percentage of inductor ripple current to increase for low load currents, the inductor value and size can be kept relatively low.

When operating in the continuous mode, the inductor current waveform ranges from a triangular to a sawtooth type of waveform (depending on the input voltage), with the average value of this current waveform equal to the DC output load current.

Inductors are available in different styles such as pot core, toroid, E-core, bobbin core, and so forth, as well as different core materials, such as ferrites and powdered iron. The least expensive, the bobbin, rod or stick core, consists of wire wound on a ferrite bobbin. This type of construction makes for an inexpensive inductor, but because the magnetic flux is not completely contained within the core, it generates more Electro-Magnetic Interference (EMI). This magnetic flux can induce voltages into nearby printed-circuit traces, thus causing problems with both the switching regulator operation and nearby sensitive circuitry, and can give incorrect scope readings because of induced voltages in the scope probe (see [Open Core Inductors](#)).

When multiple switching regulators are placed on the same PCB, open core magnetics can cause interference between two or more of the regulator circuits, especially at high currents. A torroid or E-core inductor (closed magnetic structure) must be used in these situations.

The inductors listed in the selection chart include ferrite E-core construction for Schott, ferrite bobbin core for Renco and Coilcraft, and powdered iron toroid for Pulse Engineering.

Application Information (continued)

Exceeding an inductor's maximum current rating may cause the inductor to overheat because of the copper wire losses, or the core may saturate. If the inductor begins to saturate, the inductance decreases rapidly and the inductor begins to look mainly resistive (the DC resistance of the winding). This can cause the switch current to rise very rapidly and force the switch into a cycle-by-cycle current limit, thus reducing the DC output load current. This can also result in overheating of the inductor and/or the LM2599. Different inductor types have different saturation characteristics, so keep this in mind when selecting an inductor.

The inductor manufacturer's data sheets include current and energy limits to avoid inductor saturation.

For continuous mode operation, see the inductor selection graphs in [Figure 35](#) through [Figure 38](#).

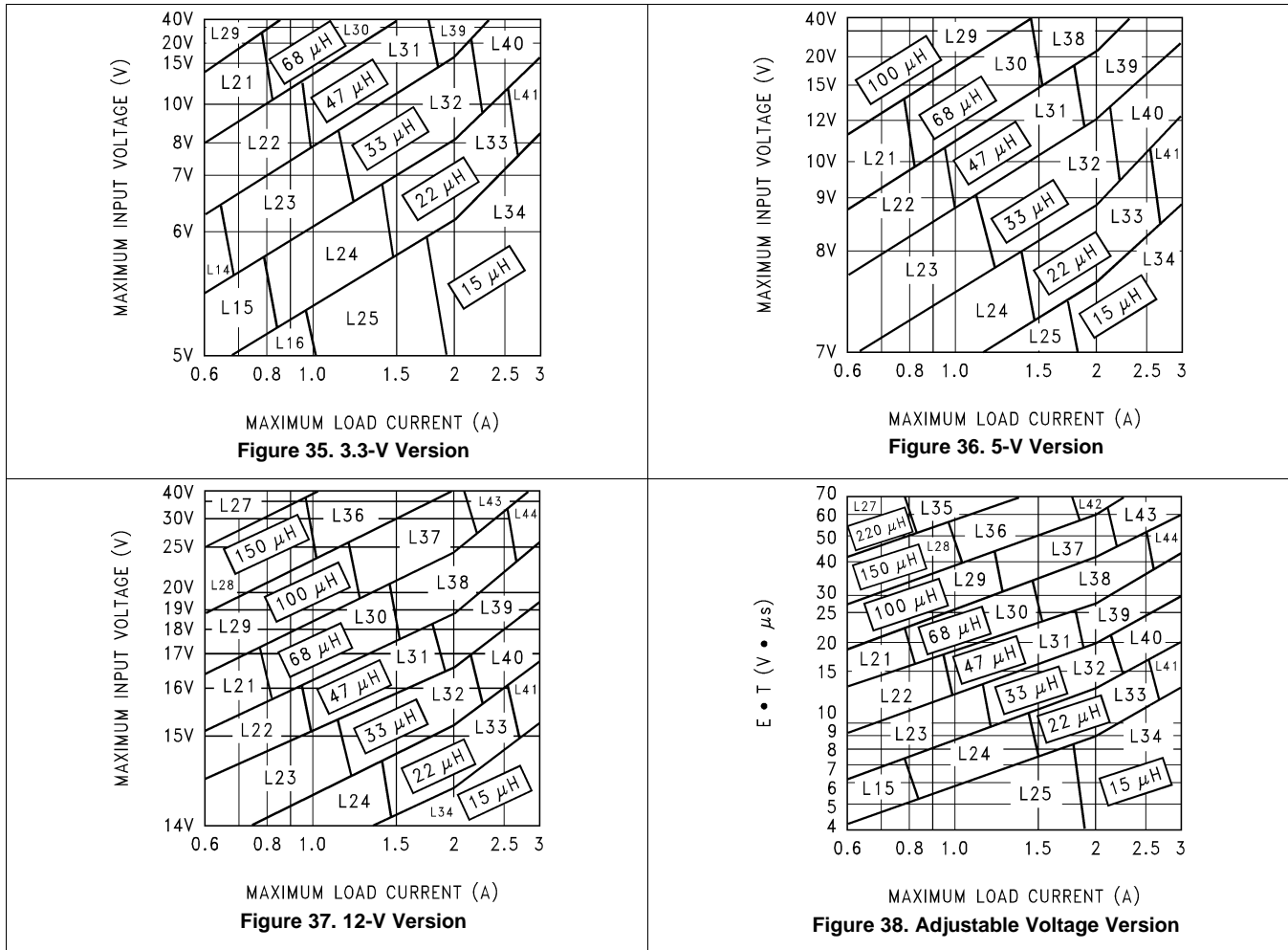

Table 1. Inductor Manufacturers Part Numbers

	INDUCTANCE (μH)	CURRENT (A)	SCHOTTKY		RENCO		PULSE ENGINEERING		COILCRAFT
			THROUGH-HOLE	SURFACE-MOUNT	THROUGH-HOLE	SURFACE-MOUNT	THROUGH-HOLE	SURFACE-MOUNT	SURFACE-MOUNT
L15	22	0.99	67148350	67148460	RL-1284-22-43	RL1500-22	PE-53815	PE-53815-S	DO3308-223
L21	68	0.99	67144070	67144450	RL-5471-5	RL1500-68	PE-53821	PE-53821-S	DO3316-683
L22	47	1.17	67144080	67144460	RL-5471-6	—	PE-53822	PE-53822-S	DO3316-473
L23	33	1.40	67144090	67144470	RL-5471-7	—	PE-53823	PE-53823-S	DO3316-333
L24	22	1.70	67148370	67148480	RL-1283-22-43	—	PE-53824	PE-53825-S	DO3316-223
L25	15	2.1	67148380	67148490	RL-1283-15-43	—	PE-53825	PE-53824-S	DO3316-153
L26	330	0.80	67144100	67144480	RL-5471-1	—	PE-53826	PE-53826-S	DOS022P-334

Application Information (continued)
Table 1. Inductor Manufacturers Part Numbers (continued)

	INDUCTANCE (μ H)	CURRENT (A)	SCHOTTKY		RENCO		PULSE ENGINEERING		COILCRAFT
			THROUGH- HOLE	SURFACE- MOUNT	THROUGH-HOLE	SURFACE- MOUNT	THROUGH- HOLE	SURFACE- MOUNT	SURFACE- MOUNT
L27	220	1.00	67144110	67144490	RL-5471-2	—	PE-53827	PE-53827-S	DOS022P-224
L28	150	1.20	67144120	67144500	RL-5471-3	—	PE-53828	PE-53828-S	DOS022P-154
L29	100	1.47	67144130	67144510	RL-5471-4	—	PE-53829	PE-53829-S	DOS022P-104
L30	68	1.78	67144140	67144520	RL-5471-5	—	PE-53830	PE-53830-S	DOS022P-683
L31	47	2.2	67144150	67144530	RL-5471-6	—	PE-53831	PE-53831-S	DOS022P-473
L32	33	2.5	67144160	67144540	RL-5471-7	—	PE-53932	PE-53932-S	DOS022P-333
L33	22	3.1	67148390	67148500	RL-1283-22-43	—	PE-53933	PE-53933-S	DOS022P-223
L34	15	3.4	67148400	67148790	RL-1283-15-43	—	PE-53934	PE-53934-S	DOS022P-153
L35	220	1.70	67144170	—	RL-5473-1	—	PE-53935	PE-53935-S	—
L36	150	2.1	67144180	—	RL-5473-4	—	PE-54036	PE-54036-S	—
L37	100	2.5	67144190	—	RL-5472-1	—	PE-54037	PE-54037-S	—
L38	68	3.1	67144200	—	RL-5472-2	—	PE-54038	PE-54038-S	—
L39	47	3.5	67144210	—	RL-5472-3	—	PE-54039	PE-54039-S	—
L40	33	3.5	67144220	67148290	RL-5472-4	—	PE-54040	PE-54040-S	—
L41	22	3.5	67144230	67148300	RL-5472-5	—	PE-54041	PE-54041-S	—
L42	150	2.7	67148410	—	RL-5473-4	—	PE-54042	PE-54042-S	—
L43	100	3.4	67144240	—	RL-5473-2	—	PE-54043	—	—
L44	68	3.4	67144250	—	RL-5473-3	—	PE-54044	—	—

9.1.8 Output Voltage Ripple and Transients

The output voltage of a switching power supply operating in the continuous mode contains a sawtooth ripple voltage at the switcher frequency, and may also contain short voltage spikes at the peaks of the sawtooth waveform.

The output ripple voltage is a function of the inductor sawtooth ripple current and the ESR of the output capacitor. A typical output ripple voltage can range from approximately 0.5% to 3% of the output voltage. To obtain low ripple voltage, the ESR of the output capacitor must be low; however, exercise caution when using extremely low ESR capacitors because they can affect the loop stability, resulting in oscillation problems. If very low output ripple voltage is needed (less than 20 mV), TI recommends a post ripple filter (see [Figure 40](#)). The inductance required is typically between 1 μ H and 5 μ H, with low DC resistance, to maintain good load regulation. A low ESR output filter capacitor is also required to assure good dynamic load response and ripple reduction. The ESR of this capacitor may be as low as desired, because it is out of the regulator feedback loop. [Figure 27](#) shows a typical output ripple voltage, with and without a post ripple filter.

When observing output ripple with a scope, it is essential that a short, low inductance scope probe ground connection be used. Most scope probe manufacturers provide a special probe terminator which is soldered onto the regulator board, preferably at the output capacitor. This provides a very short scope ground, thus eliminating the problems associated with the 3-inch ground lead normally provided with the probe, and provides a much cleaner and more accurate picture of the ripple voltage waveform.

The voltage spikes are caused by the fast switching action of the output switch, the diode, and the parasitic inductance of the output filter capacitor, and its associated wiring. To minimize these voltage spikes, the output capacitor must be designed for switching regulator applications, and the lead lengths must be kept very short. Wiring inductance, stray capacitance, as well as the scope probe used to evaluate these transients, all contribute to the amplitude of these spikes.

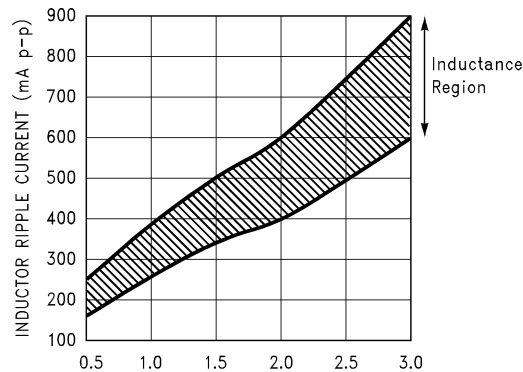

Figure 39. Peak-to-Peak Inductor Ripple Current vs Load Current

When a switching regulator is operating in the continuous mode, the inductor current waveform ranges from a triangular to a sawtooth type of waveform (depending on the input voltage). For a given input and output voltage, the peak-to-peak amplitude of this inductor current waveform remains constant. As the load current increases or decreases, the entire sawtooth current waveform also rises and falls. The average value (or the center) of this current waveform is equal to the DC load current.

If the load current drops to a low enough level, the bottom of the sawtooth current waveform reaches zero, and the switcher smoothly changes from a continuous to a discontinuous mode of operation. Most switcher designs (regardless how large the inductor value is) is forced to run discontinuous if the output is lightly loaded. This is a perfectly acceptable mode of operation.

In a switching regulator design, knowing the value of the peak-to-peak inductor ripple current (ΔI_{IND}) can be useful for determining a number of other circuit parameters. Parameters such as, peak inductor or peak switch current, minimum load current before the circuit becomes discontinuous, output ripple voltage and output capacitor ESR can all be calculated from the peak-to-peak ΔI_{IND} . When the inductor nomographs shown in [Figure 35](#) through [Figure 38](#) are used to select an inductor value, the peak-to-peak inductor ripple current can immediately be determined. [Figure 39](#) shows the range of (ΔI_{IND}) that can be expected for different load currents. [Figure 39](#) also shows how the peak-to-peak inductor ripple current (ΔI_{IND}) changes from the lower border to the upper border (for a given load current) within an inductance region. The upper border represents a higher input voltage, while the lower border represents a lower input voltage (see [Inductor Selection](#)).

These curves are only correct for continuous mode operation, and only if the inductor selection guides are used to select the inductor value

Consider the following example:

$V_{OUT} = 5\text{ V}$, maximum load current of 2.5 A

$V_{IN} = 12\text{ V}$, nominal, varying between 10 V and 16 V.

The selection guide in [Figure 36](#) shows that the vertical line for a 2.5-A load current and the horizontal line for the 12-V input voltage intersect approximately midway between the upper and lower borders of the 33- μH inductance region. A 33- μH inductor allows a peak-to-peak inductor current (ΔI_{IND}) to flow at a percentage of the maximum load current. In [Figure 39](#), follow the 2.5-A line approximately midway into the inductance region, and read the peak-to-peak inductor ripple current (ΔI_{IND}) on the left hand axis (approximately 620 mA p-p).

As the input voltage increases to 16 V, it approaches the upper border of the inductance region, and the inductor ripple current increases. [Figure 39](#) shows that for a load current of 2.5 A, the peak-to-peak inductor ripple current (ΔI_{IND}) is 620 mA with 12 V_{IN} , and can range from 740 mA at the upper border (16 V_{IN}) to 500 mA at the lower border (10 V_{IN}).

Once the ΔI_{IND} value is known, the following formulas can be used to calculate additional information about the switching regulator circuit.

- Peak Inductor or peak switch current $= \left(I_{LOAD} + \frac{\Delta I_{IND}}{2} \right) = \left(2.5\text{ A} + \frac{0.62}{2} \right) = 2.81\text{ A}$
- Minimum load current before the circuit becomes discontinuous $= \frac{\Delta I_{IND}}{2} = \frac{0.62}{2} = 0.31\text{ A}$

3. Output Ripple Voltage = $(\Delta I_{IND}) \times (\text{ESR of } C_{OUT} = 0.62 \text{ A} \times 0.1 \Omega = 62 \text{ mV}_{p-p})$

$$\begin{aligned} \text{ESR of } C_{OUT} &= \frac{\text{Output Ripple Voltage } (\Delta V_{OUT})}{\Delta I_{IND}} \\ &= \frac{0.062\text{V}}{0.62\text{A}} = 0.1\Omega \end{aligned}$$

4.

9.1.9 Open Core Inductors

Another possible source of increased output ripple voltage or unstable operation is from an open core inductor. Ferrite bobbin or stick inductors have magnetic lines of flux flowing through the air from one end of the bobbin to the other end. These magnetic lines of flux induces a voltage into any wire or PCB copper trace that comes within the inductor's magnetic field. The strength of the magnetic field, the orientation and location of the PC copper trace to the magnetic field, and the distance between the copper trace and the inductor, determine the amount of voltage generated in the copper trace. Another way of looking at this inductive coupling is to consider the PCB copper trace as one turn of a transformer (secondary) with the inductor winding as the primary. Many millivolts can be generated in a copper trace placed near an open core inductor which can cause stability problems or high output ripple voltage problems.

If unstable operation is seen, and an open core inductor is used, it is possible that the location of the inductor with respect to other PC traces may be the problem. To determine if this is the problem, temporarily raise the inductor away from the board by several inches and then check circuit operation. If the circuit now operates correctly, then the magnetic flux from the open core inductor is causing the problem. Substituting a closed core inductor such as a torroid or E-core corrects the problem, or re-arranging the PC layout may be necessary. Magnetic flux cutting the IC device ground trace, feedback trace, or the positive or negative traces of the output capacitor must be minimized.

Sometimes, placing a trace directly beneath a bobbin inductor provides good results, provided it is exactly in the center of the inductor (because the induced voltages cancel themselves out). However, problems could arise if the trace is off center. If flux problems are present, even the direction of the inductor winding can make a difference in some circuits.

This discussion on open core inductors is not to frighten users, but to alert them on what kind of problems to watch out for. Open core bobbin or *stick* inductors are an inexpensive, simple way of making a compact, efficient inductor, and they are used by the millions in many different applications.

9.2 Typical Applications

9.2.1 Fixed Output Voltage Version

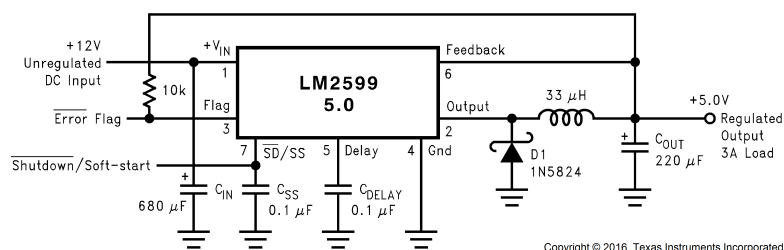

Copyright © 2016, Texas Instruments Incorporated

Component values shown are for $V_{IN} = 15 \text{ V}$,
 $V_{OUT} = 5 \text{ V}$, $I_{LOAD} = 3 \text{ A}$.
 $C_{IN} = -70\text{-}\mu\text{F}$, -50-V , aluminum electrolytic Nichicon *PL Series*
 $C_{OUT} = 220\text{-}\mu\text{F}$, 25-V aluminum electrolytic Nichicon *PL Series*
 $D1 = 5\text{-A}$, 40-V Schottky Rectifier, 1N5825
 $L1 = 68$, L38
Typical Values
 $C_{SS} = 0.1 \mu\text{F}$
 $C_{DELAY} = 0.1 \mu\text{F}$
 $R_{Pullup} = 47\text{k}$

Figure 40. Typical Application for Fixed Output Voltage Versions

Typical Applications (continued)

9.2.1.1 Design Requirements

Table 2 lists the design parameters of this example.

Table 2. Design Parameters

PARAMETER	EXAMPLE VALUE
Regulated output voltage (3.3 V, 5 V or 12 V), V_{OUT}	5 V
Maximum DC input voltage, $V_{IN(max)}$	12 V
Maximum load current, $I_{LOAD(max)}$	3 A

9.2.1.2 Detailed Design Procedure

9.2.1.2.1 Inductor Selection (L1)

Select the correct inductor value selection guide from [Figure 35](#), [Figure 36](#), or [Figure 37](#) (output voltages of 3.3 V, 5 V, or 12 V respectively). Use the inductor selection guide for the 5-V version shown in [Figure 36](#).

From the inductor value selection guide, identify the inductance region intersected by the maximum input voltage line and the maximum load current line. Each region is identified by an inductance value and an inductor code (LXX). From the inductor value selection guide shown in [Figure 36](#), the inductance region intersected by the 12-V horizontal line and the 3-A vertical line is 33 μ H, and the inductor code is L40.

Select an appropriate inductor from the four manufacturer's part numbers listed in [Table 1](#). The inductance value required is 33 μ H. See row L30 of [Table 3](#) and choose an inductor part number from any of the manufactures (in most instance, both through-hole and surface-mount inductors are available).

9.2.1.2.2 Output Capacitor Selection (C_{OUT})

In the majority of applications, low ESR (Equivalent Series Resistance) electrolytic capacitors between 82 μ F and 820 μ F and low ESR solid tantalum capacitors between 10 μ F and 470 μ F provide the best results. This capacitor must be placed close to the IC using short capacitor leads and short copper traces. Do not use capacitors larger than 820 μ F. For additional information, see [Output Capacitor \(\$C_{OUT}\$ \)](#).

To simplify the capacitor selection procedure, see [Table 3](#). This table contains different input voltages, output voltages, and load currents, and lists various inductors and output capacitors that provides the best design solutions.

From the quick design component selection table shown in [Table 3](#), locate the 5-V output voltage section. In the load current column, choose the load current line that is closest to the current needed in your application, for this example, use the 3-A line. In the maximum input voltage column, select the line that covers the input voltage needed in your application, in this example, use the 15-V line. Continuing on this line are recommended inductors and capacitors that provides the best overall performance.

The capacitor list contains both through-hole electrolytic and surface-mount tantalum capacitors from four different capacitor manufacturers. TI recommends that both the manufacturers and the manufacturer's series that are listed in the table be used. In this example, aluminum electrolytic capacitors from several different manufacturers are available with the range of ESR numbers needed:

- 330- μ F, 35-V Panasonic HFQ series
- 330- μ F, 35-V Nichicon PL series

Table 3. LM2599 Fixed Voltage Quick Design Component Selection Table

CONDITIONS			INDUCTOR		OUTPUT CAPACITOR			
					THROUGH-HOLE ELECTROLYTIC		SURFACE-MOUNT TANTALUM	
OUTPUT VOLTAGE (V)	LOAD CURRENT (A)	MAX INPUT VOLTAGE (V)	INDUCTANCE (μH)	INDUCTOR (#)	PANASONIC HFQ SERIES (μF/V)	NICHICON PL SERIES (μF/V)	AVX TPS SERIES (μF/V)	SPRAGUE 595D SERIES (μF/V)
3.3	3	5	22	L41	470/25	560/16	330/6.3	390/6.3
		7	22	L41	560/35	560/35	330/6.3	390/6.3
		10	22	L41	680/35	680/35	330/6.3	390/6.3
		40	33	L40	560/35	470/35	330/6.3	390/6.3
	2	6	22	L33	470/25	470/35	330/6.3	390/6.3
		10	33	L32	330/35	330/35	330/6.3	390/6.3
		40	47	L39	330/35	270/50	220/10	330/10
5	3	8	22	L41	470/25	560/16	220/10	330/10
		10	22	L41	560/25	560/25	220/10	330/10
		15	33	L40	330/35	330/35	220/10	330/10
		40	47	L39	330/35	270/35	220/10	330/10
	2	9	22	L33	470/25	560/16	220/10	330/10
		20	68	L38	180/35	180/35	100/10	270/10
		40	68	L38	180/35	180/35	100/10	270/10
12	3	15	22	L41	470/25	470/25	100/16	180/16
		18	33	L40	330/25	330/25	100/16	180/16
		30	68	L44	180/25	180/25	100/16	120/20
		40	68	L44	180/35	180/35	100/16	120/20
	2	15	33	L32	330/25	330/25	100/16	180/16
		20	68	L38	180/25	180/25	100/16	120/20
		40	150	L42	82/25	82/25	68/20	68/25

The capacitor voltage rating for electrolytic capacitors must be at least 1.5 times greater than the output voltage, and often much higher voltage ratings are needed to satisfy the low ESR requirements for low output ripple voltage.

For a 5-V output, a capacitor voltage rating at least 7.5 V or more is needed. But even a low ESR, switching grade, 220-μF 10-V aluminum electrolytic capacitor would exhibit approximately 225 mΩ of ESR (see the curve in [Figure 32](#) for the ESR vs voltage rating). This amount of ESR would result in relatively high output ripple voltage. To reduce the ripple to 1% of the output voltage, or less, a capacitor with a higher value or with a higher voltage rating (lower ESR) must be selected. A 16-V or 25-V capacitor reduces the ripple voltage by approximately half.

9.2.1.2.3 Catch Diode Selection (D1)

The catch diode current rating must be at least 1.3 times greater than the maximum load current. Also, if the power supply design must withstand a continuous output short, the diode must have a current rating equal to the maximum current limit of the LM2599. The most stressful condition for this diode is an overload or shorted output condition. See [Table 4](#). In this example, a 5-A, 20-V, 1N5823 Schottky diode provides the best performance, and is not overstressed even for a shorted output.

Table 4. Diode Selection Table

VR	3-A DIODES				4-A TO 6-A DIODES				
	SURFACE-MOUNT		THROUGH-HOLE		SURFACE-MOUNT		THROUGH-HOLE		
	SCHOTTKY	ULTRA FAST RECOVERY	SCHOTTKY	ULTRA FAST RECOVERY	SCHOTTKY	ULTRA FAST RECOVERY	SCHOTTKY	ULTRA FAST RECOVERY	
20 V		All of these diodes are rated to at least 50 V	1N5820	All of these diodes are rated to at least 50 V		All of these diodes are rated to at least 50 V	SR502	All of these diodes are rated to at least 50 V	
	SK32		SR302				1N5823		
			MBR320				SB520		
30 V	30WQ03		1N5821						SR503
	SK33		MBR330		50WQ03				1N5824
			31DQ03						SB530
40 V			1N5822						SR504
	SK34		SR304		50WQ04				1N5825
	MBRS340		MBR340						SR504
	30WQ04		MURS320		31DQ04		MUR320		MURS620
50 V or more	SK35	30WF10	SR305		50WF10		HER601		
	MBRS360		MBR350		50WQ05	SB550			
	30WQ05		31DQ05			50SQ080			

The reverse voltage rating of the diode must be at least 1.25 times the maximum input voltage.

This diode must be fast (short reverse recovery time) and must be placed close to the LM2599 using short leads and short printed-circuit traces. Because of their fast switching speed and low forward voltage drop, Schottky diodes provide the best performance and efficiency, and must be the first choice, especially in low output voltage applications. Ultra-fast recovery, or high-efficiency rectifiers also provide good results. Ultra-fast recovery diodes typically have reverse recovery times of 50 ns or less. Rectifiers such as the 1N5400 series are much too slow and must not be used.

9.2.1.2.4 Input Capacitor (C_{IN})

A low-ESR aluminum or tantalum bypass capacitor is needed between the input pin and ground to prevent large voltage transients from appearing at the input. In addition, the RMS current rating of the input capacitor must be selected to be at least $\frac{1}{2}$ the DC load current. The capacitor manufacturers data sheet must be checked to assure that this current rating is not exceeded. The curve shown in [Figure 31](#) shows typical RMS current ratings for several different aluminum electrolytic capacitor values.

This capacitor must be placed close to the IC using short leads and the voltage rating must be approximately 1.5 times the maximum input voltage.

If solid tantalum input capacitors are used, TI recommends that they be surge current tested by the manufacturer.

Use caution when using ceramic capacitors for input bypassing, because it may cause severe ringing at the V_{IN} pin.

The important parameters for the Input capacitor are the input voltage rating and the RMS current rating. With a nominal input voltage of 12 V, an aluminum electrolytic capacitor with a voltage rating greater than 18 V ($1.5 \times V_{IN}$) would be needed. The next higher capacitor voltage rating is 25 V.

The RMS current rating requirement for the input capacitor in a buck regulator is approximately $\frac{1}{2}$ the DC load current. In this example, with a 3-A load, a capacitor with a RMS current rating of at least 1.5 A is needed. The curves shown in [Figure 31](#) can be used to select an appropriate input capacitor. From the curves, locate the 35-V line and note which capacitor values have RMS current ratings greater than 1.5 A. A 680- μ F, 35-V capacitor could be used.

For a through-hole design, a 680- μ F, 35-V electrolytic capacitor (Panasonic HFQ series or Nichicon PL series or equivalent) would be adequate. Other types or other manufacturers capacitors can be used provided the RMS ripple current ratings are adequate.

For surface-mount designs, solid tantalum capacitors are recommended. The TPS series available from AVX, and the 593D series from Sprague are both surge current tested. For additional information, see [Input Capacitor \(\$C_{IN}\$ \)](#).

9.2.1.3 Application Curves

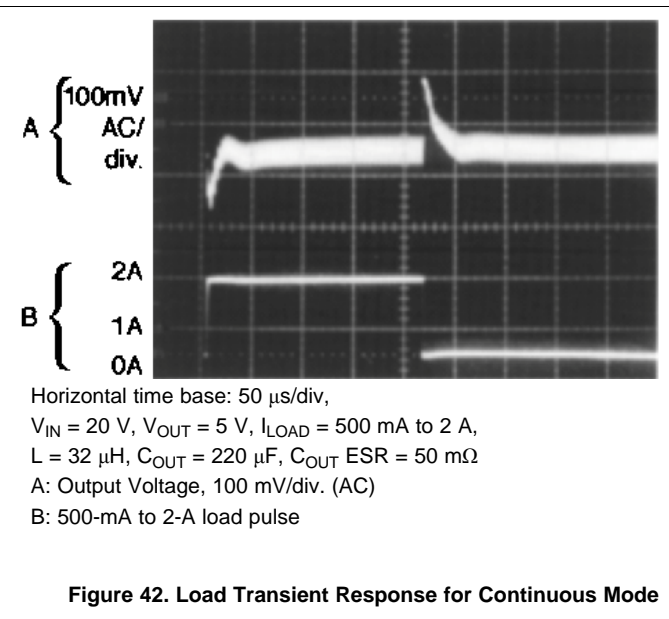
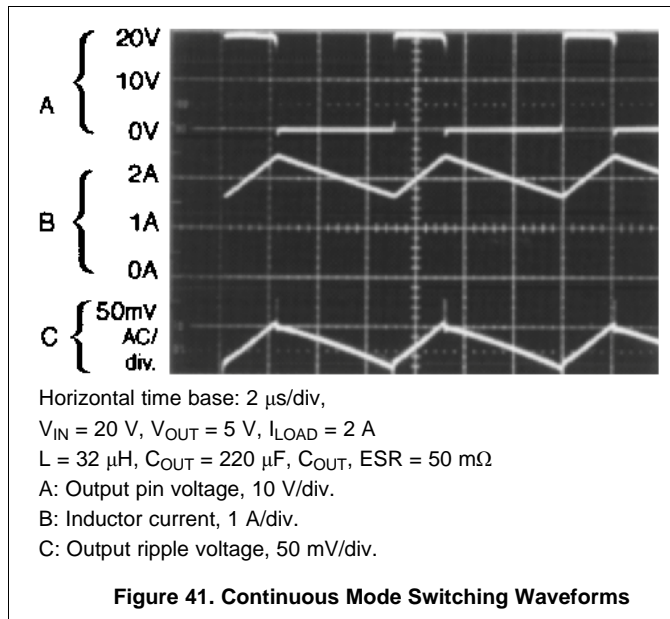

9.2.2 Adjustable Output Voltage Version

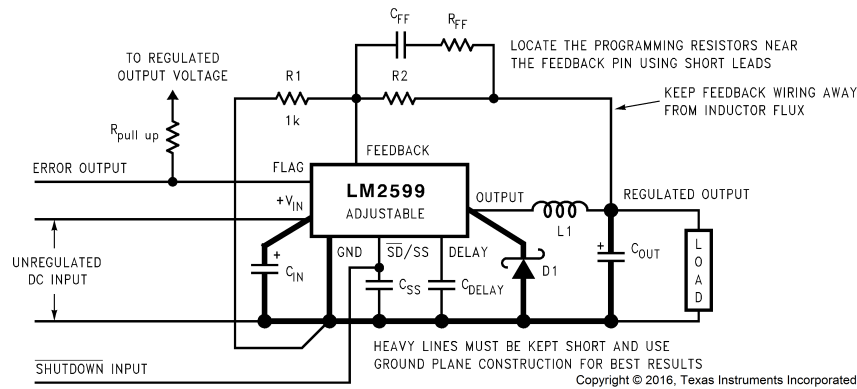

$$V_{OUT} = V_{REF} \left(1 + \frac{R_2}{R_1} \right)$$

where $V_{REF} = 1.23 \text{ V}$

$$R_2 = R_1 \left(\frac{V_{OUT}}{V_{REF}} - 1 \right)$$

Select R_1 to be approximately $1 \text{ k}\Omega$, use a 1% resistor for best stability.

Component values shown are for $V_{IN} = 20 \text{ V}$,

$V_{OUT} = 10 \text{ V}$, $I_{LOAD} = 3 \text{ A}$.

$C_{IN} = 470\text{-}\mu\text{F}$, 35-V, aluminum electrolytic Nichicon *PL Series*

$C_{OUT} = 220\text{-}\mu\text{F}$, 35-V, aluminum electrolytic Nichicon *PL Series*

$D1 = 5\text{-A}$, 30-V Schottky Rectifier, 1N5824

$L1 = 68 \text{ }\mu\text{H}$, L38

$R_1 = 1 \text{ k}\Omega$, 1%

$R_2 = 7.15\text{k}$, 1%

$C_{FF} = 3.3 \text{ nF}$

$R_{FF} = 3 \text{ k}\Omega$

Typical Values

$C_{SS} = 0.1 \text{ }\mu\text{F}$

$C_{DELAY} = 0.1 \text{ }\mu\text{F}$

$R_{PULLUP} = 4.7\text{k}$

Figure 43. Typical Application for Adjustable Output Voltage Versions

9.2.2.1 Design Requirements

Table 5 lists the design parameters of this example.

Table 5. Design Parameters

PARAMETER	EXAMPLE VALUE
Regulated output voltage, V_{OUT}	20 V
Maximum DC Input voltage, $V_{IN(max)}$	28 V
Maximum load current, $I_{LOAD(max)}$	3 A
Switching frequency, F	Fixed at a nominal 150 kHz

9.2.2.2 Detailed Design Procedure

9.2.2.2.1 Programming Output Voltage

Select R_1 and R_2 .

Use Equation 1 to select the appropriate resistor values.

$$V_{OUT} = V_{REF} \left(1 + \frac{R_2}{R_1} \right) \quad \text{where } V_{REF} = 1.23\text{V} \quad (1)$$

Select a value for R_1 between $240 \text{ }\Omega$ and $1.5 \text{ k}\Omega$ using Equation 2. The lower resistor values minimize noise pickup in the sensitive feedback pin (for the lowest temperature coefficient and the best stability with time, use 1% metal film resistors).

$$R_2 = R_1 \left(\frac{V_{OUT}}{V_{REF}} - 1 \right) \quad (2)$$

Select R_1 to be 1 k Ω , 1%. Solve for R_2 with [Equation 3](#).

$$R_2 = R_1 \left(\frac{V_{OUT}}{V_{REF}} - 1 \right) = 1k \left(\frac{20V}{1.23V} - 1 \right) \quad (3)$$

$R_2 = 1k (16.26 - 1) = 15.26k$, closest 1% value is 15.4 k Ω .

$R_2 = 15.4 \text{ k}\Omega$.

9.2.2.2 Inductor Selection (L1)

1. Calculate the inductor Volt \times microsecond constant $E \times T$ ($V \times \mu s$) from [Equation 4](#).

$$E \cdot T = (V_{IN} - V_{OUT} - V_{SAT}) \cdot \frac{V_{OUT} + V_D}{V_{IN} - V_{SAT} + V_D} \cdot \frac{1000}{150 \text{ kHz}} (V \cdot \mu s)$$

where

- V_{SAT} = internal switch saturation voltage = 1.16 V
 - V_D = diode forward voltage drop = 0.5 V
- (4)

Calculate the inductor Volt \times microsecond constant ($E \times T$) with [Equation 5](#).

$$E \cdot T = (28 - 20 - 1.16) \cdot \frac{20 + 0.5}{28 - 1.16 + 0.5} \cdot \frac{1000}{150} (V \cdot \mu s)$$

$$E \cdot T = (6.84) \cdot \frac{20.5}{27.34} \cdot 6.67 (V \cdot \mu s) = 34.2 (V \cdot \mu s) \quad (5)$$

2. Use the $E \times T$ value from the previous formula and match it with the $E \times T$ number on the vertical axis of the Inductor Value Selection Guide shown in [Figure 38](#).

$$E \times T = 34.2 (V \times \mu s)$$

3. On the horizontal axis, select the maximum load current.

$$I_{LOAD(max)} = 3 \text{ A}$$

4. Identify the inductance region intersected by the $E \times T$ value and the Maximum Load Current value. Each region is identified by an inductance value and an inductor code (LXX). From the inductor value selection guide shown in [Figure 38](#), the inductance region intersected by the 34 ($V \times \mu s$) horizontal line and the 3-A vertical line is 47 μH , and the inductor code is L39.
5. Select an appropriate inductor from the four manufacturer's part numbers listed in [Table 1](#). From the table in [Table 1](#), locate line L39, and select an inductor part number from the list of manufacturers part numbers.

9.2.2.3 Output Capacitor Selection (C_{OUT})

In the majority of applications, low-ESR electrolytic or solid tantalum capacitors between 82 μF and 820 μF provide the best results. This capacitor must be placed close to the IC using short capacitor leads and short copper traces. Do not use capacitors larger than 820 μF . For additional information, see [Output Capacitor \(\$C_{OUT}\$ \)](#).

To simplify the capacitor selection procedure, see [Table 6](#). This table contains different output voltages, and lists various output capacitors that provides the best design solutions.

From the quick design table shown in [Table 6](#), locate the output voltage column. From that column, locate the output voltage closest to the output voltage in your application. In this example, select the 24-V line. Under the [Output Capacitor \(\$C_{OUT}\$ \)](#) section, select a capacitor from the list of through-hole electrolytic or surface-mount tantalum types from four different capacitor manufacturers. TI recommends that both the manufacturers and the manufacturers series that are listed in the table be used.

In this example, through-hole aluminum electrolytic capacitors from several different manufacturers are available.

- 220-V, 35-A Panasonic HFQ series
- 150-V, 35-A Nichicon PL series

The capacitor voltage rating must be at least 1.5 times greater than the output voltage, and often much higher voltage ratings are needed to satisfy the low ESR requirements needed for low output ripple voltage.

For a 20-V output, a capacitor rating of at least 30 V or more is needed. In this example, either a 35-V or 50-V capacitor would work. A 50-V rating was chosen because it has a lower ESR which provides a lower output ripple voltage.

Other manufacturers or other types of capacitors may also be used, provided the capacitor specifications (especially the 100-kHz ESR) closely match the types listed in the table. See the capacitor manufacturers data sheet for this information.

9.2.2.2.4 Feedforward Capacitor (C_{FF})

For output voltages greater than approximately 10 V, an additional capacitor is required. The compensation capacitor is typically between 100 pF and 33 nF, and is wired in parallel with the output voltage setting resistor, R_2 . It provides additional stability for high output voltages, low input-output voltages, and/or very low ESR output capacitors, such as solid tantalum capacitors.

$$C_{FF} = \frac{1}{31 \times 10^3 \times R_2} \quad (6)$$

This capacitor type can be ceramic, plastic, silver mica, and so forth (because of the unstable characteristics of ceramic capacitors made with Z5U material, they are not recommended).

[Table 6](#) contains feedforward capacitor values for various output voltages. In this example, a 560-pF capacitor is needed.

Table 6. Output Capacitor and Feedforward Capacitor Selection Table

OUTPUT VOLTAGE (V)	THROUGH-HOLE OUTPUT CAPACITOR			SURFACE-MOUNT OUTPUT CAPACITOR		
	PANASONIC HFQ SERIES ($\mu\text{F/V}$)	NICHICON PL SERIES ($\mu\text{F/V}$)	FEEDFORWARD CAPACITOR	AVX TPS SERIES ($\mu\text{F/V}$)	SPRAGUE 595D SERIES ($\mu\text{F/V}$)	FEEDFORWARD CAPACITOR
2	820/35	820/35	33 nF	330/6.3	470/4	33 nF
4	560/35	470/35	10 nF	330/6.3	390/6.3	10 nF
6	470/25	470/25	3.3 nF	220/10	330/10	3.3 nF
9	330/25	330/25	1.5 nF	100/16	180/16	1.5 nF
12	330/25	330/25	1 nF	100/16	180/16	1 nF
15	220/35	220/35	680 pF	68/20	120/20	680 pF
24	220/35	150/35	560 pF	33/25	33/25	220 pF
28	100/50	100/50	390 pF	10/35	15/50	220 pF

9.2.2.2.5 Catch Diode Selection (D1)

The catch diode current rating must be at least 1.3 times greater than the maximum load current. Also, if the power supply design must withstand a continuous output short, the diode must have a current rating equal to the maximum current limit of the LM2599. The most stressful condition for this diode is an overload or shorted output condition (see [Table 4](#)). Schottky diodes provide the best performance, and in this example a 3-A, 40-V, 1N5825 Schottky diode would be a good choice. The 3-A diode rating is more than adequate and is not overstressed even for a shorted output.

The reverse voltage rating of the diode must be at least 1.25 times the maximum input voltage.

This diode must be fast (short reverse recovery time) and must be placed close to the LM2599 using short leads and short printed-circuit traces. Because of their fast switching speed and low forward voltage drop, Schottky diodes provide the best performance and efficiency, and must be the first choice, especially in low output voltage applications. Ultra-fast recovery, or high-efficiency rectifiers are also a good choice, but some types with an abrupt turn-off characteristic may cause instability or EMI problems. Ultra-fast recovery diodes typically have reverse recovery times of 50 ns or less. Rectifiers such as the 1N4001 series are much too slow and must not be used.

9.2.2.2.6 Input Capacitor (C_{IN})

A low-ESR aluminum or tantalum bypass capacitor is needed between the input pin and ground to prevent large voltage transients from appearing at the input. In addition, the RMS current rating of the input capacitor must be selected to be at least $\frac{1}{2}$ the DC load current. The capacitor manufacturers data sheet must be checked to assure that this current rating is not exceeded. The curve shown in [Figure 31](#) shows typical RMS current ratings for several different aluminum electrolytic capacitor values.

This capacitor must be placed close to the IC using short leads and the voltage rating must be approximately 1.5 times the maximum input voltage.

If solid tantalum input capacitors are used, TI recommends that they be surge current tested by the manufacturer.

Use caution when using a high dielectric constant ceramic capacitor for input bypassing, because it may cause severe ringing at the V_{IN} pin.

The important parameters for the Input capacitor are the input voltage rating and the RMS current rating. With a nominal input voltage of 28 V, an aluminum electrolytic capacitor with a voltage rating greater than 42 V ($1.5 \times V_{IN}$) would be needed. Because the next higher capacitor voltage rating is 50 V, a 50-V capacitor must be used. The capacitor voltage rating of ($1.5 \times V_{IN}$) is a conservative guideline, and can be modified somewhat if desired.

The RMS current rating requirement for the input capacitor of a buck regulator is approximately $\frac{1}{2}$ the DC load current. In this example, with a 3-A load, a capacitor with a RMS current rating of at least 1.5 A is needed.

The curves shown in [Figure 31](#) can be used to select an appropriate input capacitor. From the curves, locate the 50-V line and note which capacitor values have RMS current ratings greater than 1.5 A. Either a 470- μ F or 680- μ F, 50-V capacitor could be used.

For a through-hole design, a 680- μ F/50V electrolytic capacitor (Panasonic HFQ series or Nichicon PL series or equivalent) would be adequate. Other types or other manufacturers capacitors can be used provided the RMS ripple current ratings are adequate.

For surface-mount designs, solid tantalum capacitors can be used, but caution must be exercised with regard to the capacitor surge current rating. The TPS series available from AVX, and the 593D series from Sprague are both surge current tested. For additional information, see [Input Capacitor \(\$C_{IN}\$ \)](#).

9.2.2.3 Application Curves

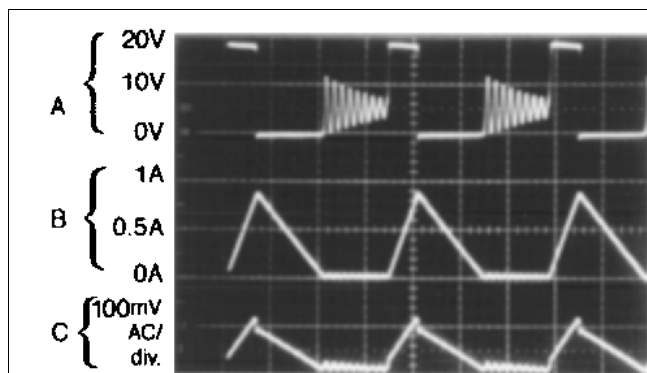

Horizontal time base: 2 μ s/div
 $V_{IN} = 20$ V, $V_{OUT} = 5$ V, $I_{LOAD} = 500$ mA,
 $L = 10$ μ H, $C_{OUT} = 330$ μ F, C_{OUT} ESR = 45 m Ω
 A: Output pin voltage, 10 V/div.
 B: Inductor current, 0.5 A/div.
 C: Output ripple voltage, 100 mV/div.

Figure 44. Discontinuous Mode Switching Waveforms

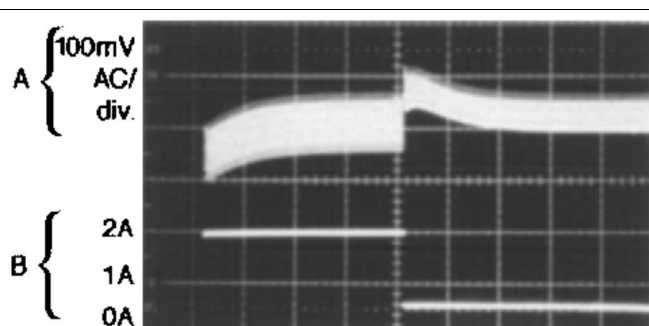

Horizontal Time Base: 200 μ s/div
 $V_{IN} = 20$ V, $V_{OUT} = 5$ V, $I_{LOAD} = 500$ mA to 2 A
 $L = 10$ μ H, $C_{OUT} = 330$ μ F, C_{OUT} ESR = 45 m Ω
 A: Output voltage, 100 mV/div. (AC)
 B: 500-mA to 2-A load pulse

Figure 45. Load Transient Response for Discontinuous Mode

10 Power Supply Recommendations

The LM2599 is designed to operate from an input voltage supply up to 40 V. This input supply must be well regulated and able to withstand maximum input current and maintain a stable voltage.

11 Layout

11.1 Layout Guidelines

As in any switching regulator, layout is very important. Rapidly switching currents associated with wiring inductance can generate voltage transients which can cause problems. For minimal inductance and ground loops, the wires indicated by heavy lines must be wide printed-circuit traces and must be kept as short as possible. For best results, external components must be placed as close to the switcher IC as possible using ground plane construction or single point grounding.

If open core inductors are used, take special care to select the location and positioning of this type of inductor. Allowing the inductor flux to intersect sensitive feedback, IC groundpath and C_{OUT} wiring can cause problems.

When using the adjustable version, take special care to select the location of the feedback resistors and the associated wiring. Physically place both resistors near the IC, and route the wiring away from the inductor, especially an open core type of inductor (see [Open Core Inductors](#) for more information).

11.2 Layout Examples

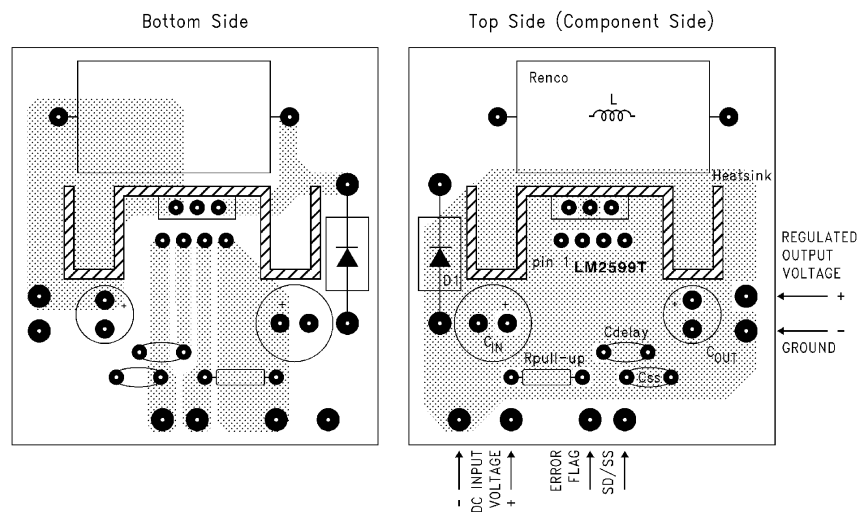

C_{IN} = 470- μ F, 50-V, aluminum electrolytic Panasonic *HFQ Series*
 C_{OUT} = 330- μ F, 35-V, aluminum electrolytic Panasonic *HFQ Series*
 D1 = 5-A, 40-V Schottky rectifier, 1N5825
 L1 = 47- μ H, L39, Renco through hole
 $R_{PULL\ UP}$ = 10k
 C_{DELAY} = 0.1 μ F
 $C_{SD/SS}$ = 0.1 μ F
 Thermalloy heat sink #7020

Figure 46. Typical Through-Hole PCB Layout, Fixed Output (1x Size), Double-Sided

Layout Examples (continued)

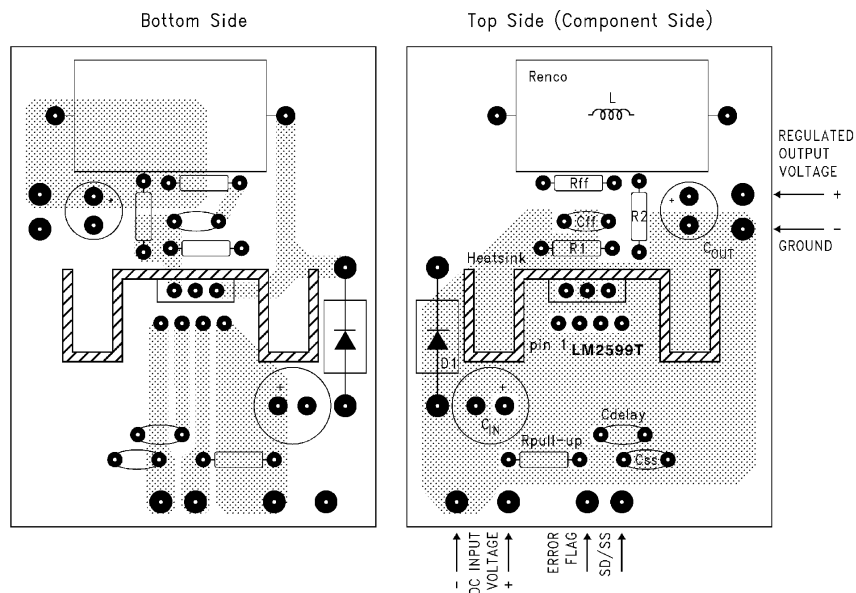

C_{IN} = 470- μ F, 50-V, aluminum electrolytic Panasonic, *HFQ Series*
 C_{OUT} = 220- μ F, 35-V, aluminum electrolytic Panasonic, *HFQ Series*
 D1 = 5-A, 40-V Schottky Rectifier, 1N5825
 L1 = 47- μ H, L39, Renco, through-hole
 R_1 = 1 k Ω , 1%
 R_2 = Use formula in [Detailed Design Procedure](#)
 C_{FF} = See [Figure 35](#)
 R_{FF} = See [Feedforward Capacitor \(\$C_{FF}\$ \) for Adjustable Output Voltage Version Only](#)
 $R_{PULL\ UP}$ = 10k
 C_{DELAY} = 0.1 μ F
 $C_{SD/SS}$ = 0.1 μ F
 Thermalloy heat sink #7020

Figure 47. Typical Through-Hole PCB Layout, Adjustable Output (1x Size), Double-Sided

11.3 Thermal Considerations

The LM2599 is available in two packages, a 7-pin TO-220 and a 7-pin surface-mount TO-263.

The TO-220 package needs a heat sink under most conditions. The size of the heat sink depends on the input voltage, the output voltage, the load current and the ambient temperature. The curves in [Figure 48](#) show the LM2599T junction temperature rises above ambient temperature for a 3-A load and different input and output voltages. The data for these curves was taken with the LM2599T (TO-220 package) operating as a buck switching regulator in an ambient temperature of 25°C (still air). These temperature rise numbers are all approximate and there are many factors that can affect these temperatures. Higher ambient temperatures require more heat sinking.

The TO-263 surface-mount package tab is designed to be soldered to the copper on a printed-circuit board. The copper and the board are the heat sink for this package and the other heat producing components, such as the catch diode and inductor. The PCB copper area that the package is soldered to must be at least 0.4 in², and ideally must have 2 or more square inches of 2-oz. (0.0028 in) copper. Additional copper area improves the thermal characteristics, but with copper areas greater than approximately 6 in², only small improvements in heat dissipation are realized. If further thermal improvements are needed, double-sided, multilayer PCBs with large copper areas or airflow are recommended.

Thermal Considerations (continued)

The curves shown in Figure 49 show the LM2599S (TO-263 package) junction temperature rise above ambient temperature with a 2-A load for various input and output voltages. This data was taken with the circuit operating as a buck switching regulator with all components mounted on a PCB to simulate the junction temperature under actual operating conditions. This curve can be used for a quick check for the approximate junction temperature for various conditions, but be aware that there are many factors that can affect the junction temperature. When load currents higher than 2 A are used, double-sided or multilayer PCBs with large copper areas or airflow might be needed, especially for high ambient temperatures and high output voltages.

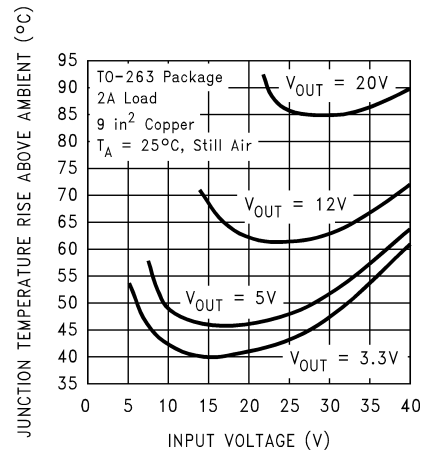

CIRCUIT DATA FOR TEMPERATURE RISE CURVE TO-220 PACKAGE (NDZ)

Capacitors	Through-hole electrolytic
Inductor	Through-hole Renco
Diode	Through-hole, 5-A, 40-V Schottky
PCB	3-square inch, single-sided, 2-oz copper (0.0028")

Figure 48. Junction Temperature Rise, TO-220

Thermal Considerations (continued)

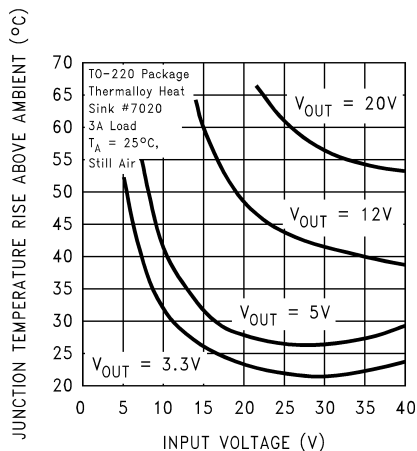

CIRCUIT DATA FOR TEMPERATURE RISE CURVE TO-263 PACKAGE (KTW)

Capacitors	Surface-mount, tantalum molded D size
Inductor	Surface-mount, Pulse engineering, 68 μH
Diode	Surface-mount, 5-A, 40-V, Schottky
PCB	9-square inch, single-sided, 2-oz copper (0.0028")

Figure 49. Junction Temperature Rise, TO-263

For the best thermal performance, wide copper traces and generous amounts of printed-circuit board copper must be used in the board layout. (One exception to this is the output (switch) pin, which must not have large areas of copper). Large areas of copper provide the best transfer of heat (lower thermal resistance) to the surrounding air, and moving air lowers the thermal resistance even further.

Package thermal resistance and junction temperature rise numbers are all approximate, and there are many factors that affects these numbers. Some of these factors include board size, shape, thickness, position, location, and even board temperature. Other factors are, trace width, total printed-circuit copper area, copper thickness, single- or double-sided, multilayer board and the amount of solder on the board. The effectiveness of the PCB to dissipate heat also depends on the size, quantity and spacing of other components on the board, as well as whether the surrounding air is still or moving. Furthermore, some of these components such as the catch diode adds heat to the PCB and the heat can vary as the input voltage changes. For the inductor, depending on the physical size, type of core material and the DC resistance, it could either act as a heat sink taking heat away from the board, or it could add heat to the board.

12 Device and Documentation Support

12.1 Community Resources

The following links connect to TI community resources. Linked contents are provided "AS IS" by the respective contributors. They do not constitute TI specifications and do not necessarily reflect TI's views; see TI's [Terms of Use](#).

TI E2E™ Online Community *TI's Engineer-to-Engineer (E2E) Community*. Created to foster collaboration among engineers. At e2e.ti.com, you can ask questions, share knowledge, explore ideas and help solve problems with fellow engineers.

Design Support *TI's Design Support* Quickly find helpful E2E forums along with design support tools and contact information for technical support.

12.2 Trademarks

E2E is a trademark of Texas Instruments.
 SIMPLE SWITCHER is a registered trademark of Texas Instruments.
 All other trademarks are the property of their respective owners.

12.3 Electrostatic Discharge Caution



These devices have limited built-in ESD protection. The leads should be shorted together or the device placed in conductive foam during storage or handling to prevent electrostatic damage to the MOS gates.

12.4 Glossary

[SLYZ022](#) — *TI Glossary*.

This glossary lists and explains terms, acronyms, and definitions.

13 Mechanical, Packaging, and Orderable Information

The following pages include mechanical, packaging, and orderable information. This information is the most current data available for the designated devices. This data is subject to change without notice and revision of this document. For browser-based versions of this data sheet, refer to the left-hand navigation.

PACKAGING INFORMATION

Orderable Device	Status (1)	Package Type	Package Drawing	Pins	Package Qty	Eco Plan (2)	Lead/Ball Finish (6)	MSL Peak Temp (3)	Op Temp (°C)	Device Marking (4/5)	Samples
LM2599S-12/NOPB	ACTIVE	DDPAK/ TO-263	KTW	7	45	Pb-Free (RoHS Exempt)	CU SN	Level-3-245C-168 HR	-40 to 125	LM2599S -12 P+	Samples
LM2599S-3.3/NOPB	ACTIVE	DDPAK/ TO-263	KTW	7	45	Pb-Free (RoHS Exempt)	CU SN	Level-3-245C-168 HR	-40 to 125	LM2599S -3.3 P+	Samples
LM2599S-5.0	NRND	DDPAK/ TO-263	KTW	7	45	TBD	Call TI	Call TI	-40 to 125	LM2599S -5.0 P+	
LM2599S-5.0/NOPB	ACTIVE	DDPAK/ TO-263	KTW	7	45	Pb-Free (RoHS Exempt)	CU SN	Level-3-245C-168 HR	-40 to 125	LM2599S -5.0 P+	Samples
LM2599S-ADJ/NOPB	ACTIVE	DDPAK/ TO-263	KTW	7	45	Pb-Free (RoHS Exempt)	CU SN	Level-3-245C-168 HR	-40 to 125	LM2599S -ADJ P+	Samples
LM2599SX-12/NOPB	ACTIVE	DDPAK/ TO-263	KTW	7	500	Pb-Free (RoHS Exempt)	CU SN	Level-3-245C-168 HR	-40 to 125	LM2599S -12 P+	Samples
LM2599SX-3.3/NOPB	ACTIVE	DDPAK/ TO-263	KTW	7	500	Pb-Free (RoHS Exempt)	CU SN	Level-3-245C-168 HR	-40 to 125	LM2599S -3.3 P+	Samples
LM2599SX-5.0/NOPB	ACTIVE	DDPAK/ TO-263	KTW	7	500	Pb-Free (RoHS Exempt)	CU SN	Level-3-245C-168 HR	-40 to 125	LM2599S -5.0 P+	Samples
LM2599SX-ADJ/NOPB	ACTIVE	DDPAK/ TO-263	KTW	7	500	Pb-Free (RoHS Exempt)	CU SN	Level-3-245C-168 HR	-40 to 125	LM2599S -ADJ P+	Samples
LM2599T-12/NOPB	ACTIVE	TO-220	NDZ	7	45	Green (RoHS & no Sb/Br)	CU SN	Level-1-NA-UNLIM	-40 to 125	LM2599T -12 P+	Samples
LM2599T-5.0/NOPB	ACTIVE	TO-220	NDZ	7	45	Green (RoHS & no Sb/Br)	CU SN	Level-1-NA-UNLIM	-40 to 125	LM2599T -5.0 P+	Samples
LM2599T-ADJ	NRND	TO-220	NDZ	7	45	TBD	Call TI	Call TI	-40 to 125	LM2599T -ADJ P+	
LM2599T-ADJ/NOPB	ACTIVE	TO-220	NDZ	7	45	Green (RoHS & no Sb/Br)	CU SN	Level-1-NA-UNLIM	-40 to 125	LM2599T -ADJ P+	Samples

(1) The marketing status values are defined as follows:

ACTIVE: Product device recommended for new designs.

LIFEBUY: TI has announced that the device will be discontinued, and a lifetime-buy period is in effect.

NRND: Not recommended for new designs. Device is in production to support existing customers, but TI does not recommend using this part in a new design.

PREVIEW: Device has been announced but is not in production. Samples may or may not be available.

OBSELETE: TI has discontinued the production of the device.

(2) **RoHS:** TI defines "RoHS" to mean semiconductor products that are compliant with the current EU RoHS requirements for all 10 RoHS substances, including the requirement that RoHS substance do not exceed 0.1% by weight in homogeneous materials. Where designed to be soldered at high temperatures, "RoHS" products are suitable for use in specified lead-free processes. TI may reference these types of products as "Pb-Free".

RoHS Exempt: TI defines "RoHS Exempt" to mean products that contain lead but are compliant with EU RoHS pursuant to a specific EU RoHS exemption.

Green: TI defines "Green" to mean the content of Chlorine (Cl) and Bromine (Br) based flame retardants meet JS709B low halogen requirements of ≤ 1000 ppm threshold. Antimony trioxide based flame retardants must also meet the ≤ 1000 ppm threshold requirement.

(3) MSL, Peak Temp. - The Moisture Sensitivity Level rating according to the JEDEC industry standard classifications, and peak solder temperature.

(4) There may be additional marking, which relates to the logo, the lot trace code information, or the environmental category on the device.

(5) Multiple Device Markings will be inside parentheses. Only one Device Marking contained in parentheses and separated by a "~" will appear on a device. If a line is indented then it is a continuation of the previous line and the two combined represent the entire Device Marking for that device.

(6) Lead/Ball Finish - Orderable Devices may have multiple material finish options. Finish options are separated by a vertical ruled line. Lead/Ball Finish values may wrap to two lines if the finish value exceeds the maximum column width.

Important Information and Disclaimer: The information provided on this page represents TI's knowledge and belief as of the date that it is provided. TI bases its knowledge and belief on information provided by third parties, and makes no representation or warranty as to the accuracy of such information. Efforts are underway to better integrate information from third parties. TI has taken and continues to take reasonable steps to provide representative and accurate information but may not have conducted destructive testing or chemical analysis on incoming materials and chemicals. TI and TI suppliers consider certain information to be proprietary, and thus CAS numbers and other limited information may not be available for release.

In no event shall TI's liability arising out of such information exceed the total purchase price of the TI part(s) at issue in this document sold by TI to Customer on an annual basis.

TAPE AND REEL INFORMATION

QUADRANT ASSIGNMENTS FOR PIN 1 ORIENTATION IN TAPE

*All dimensions are nominal

Device	Package Type	Package Drawing	Pins	SPQ	Reel Diameter (mm)	Reel Width W1 (mm)	A0 (mm)	B0 (mm)	K0 (mm)	P1 (mm)	W (mm)	Pin1 Quadrant
LM2599SX-12/NOPB	DDPAK/ TO-263	KTW	7	500	330.0	24.4	10.75	14.85	5.0	16.0	24.0	Q2
LM2599SX-3.3/NOPB	DDPAK/ TO-263	KTW	7	500	330.0	24.4	10.75	14.85	5.0	16.0	24.0	Q2
LM2599SX-5.0/NOPB	DDPAK/ TO-263	KTW	7	500	330.0	24.4	10.75	14.85	5.0	16.0	24.0	Q2
LM2599SX-ADJ/NOPB	DDPAK/ TO-263	KTW	7	500	330.0	24.4	10.75	14.85	5.0	16.0	24.0	Q2

TAPE AND REEL BOX DIMENSIONS

*All dimensions are nominal

Device	Package Type	Package Drawing	Pins	SPQ	Length (mm)	Width (mm)	Height (mm)
LM2599SX-12/NOPB	DDPAK/TO-263	KTW	7	500	367.0	367.0	45.0
LM2599SX-3.3/NOPB	DDPAK/TO-263	KTW	7	500	367.0	367.0	45.0
LM2599SX-5.0/NOPB	DDPAK/TO-263	KTW	7	500	367.0	367.0	45.0
LM2599SX-ADJ/NOPB	DDPAK/TO-263	KTW	7	500	367.0	367.0	45.0

NDZ0007B

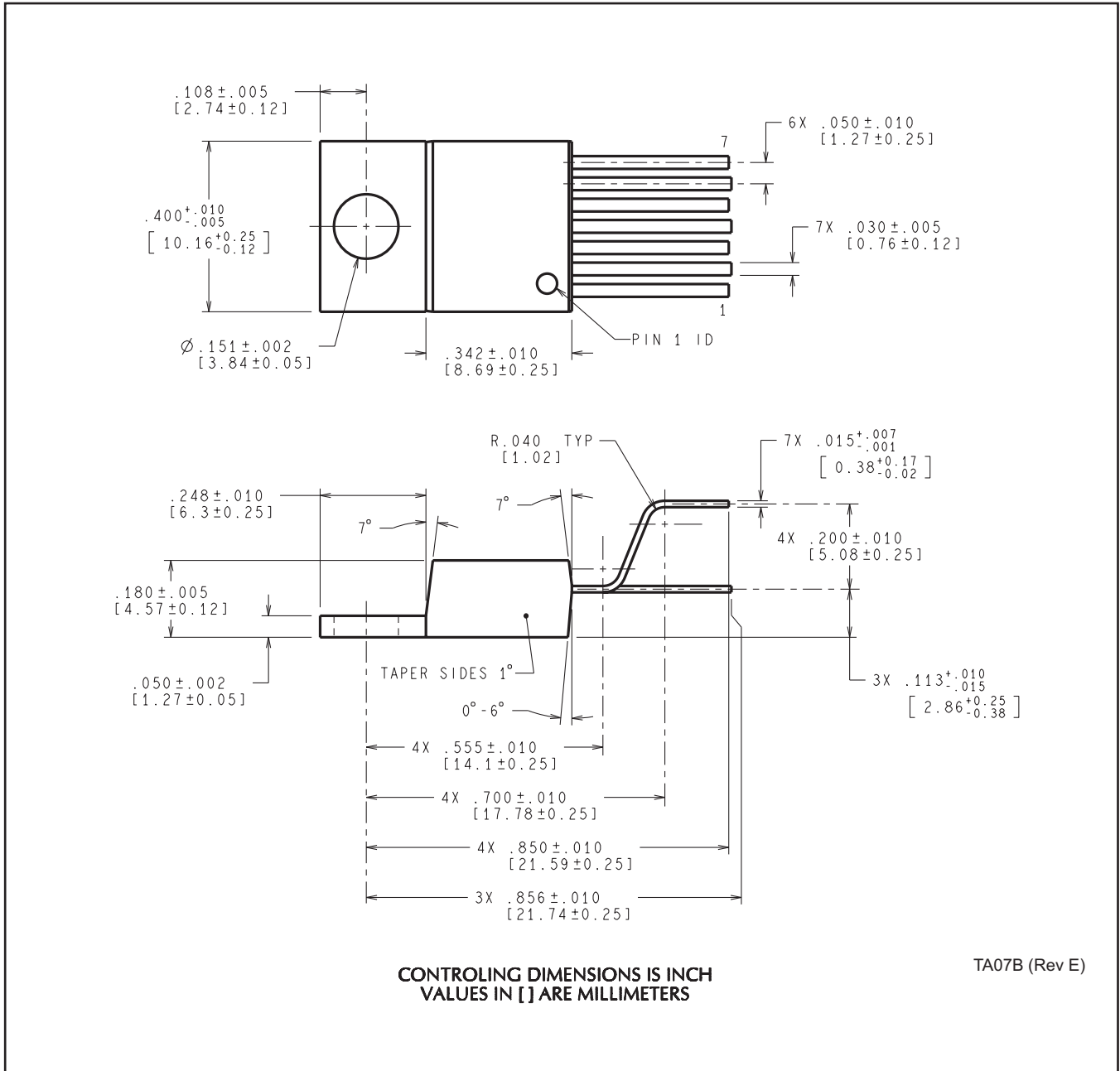

IMPORTANT NOTICE AND DISCLAIMER

TI PROVIDES TECHNICAL AND RELIABILITY DATA (INCLUDING DATASHEETS), DESIGN RESOURCES (INCLUDING REFERENCE DESIGNS), APPLICATION OR OTHER DESIGN ADVICE, WEB TOOLS, SAFETY INFORMATION, AND OTHER RESOURCES "AS IS" AND WITH ALL FAULTS, AND DISCLAIMS ALL WARRANTIES, EXPRESS AND IMPLIED, INCLUDING WITHOUT LIMITATION ANY IMPLIED WARRANTIES OF MERCHANTABILITY, FITNESS FOR A PARTICULAR PURPOSE OR NON-INFRINGEMENT OF THIRD PARTY INTELLECTUAL PROPERTY RIGHTS.

These resources are intended for skilled developers designing with TI products. You are solely responsible for (1) selecting the appropriate TI products for your application, (2) designing, validating and testing your application, and (3) ensuring your application meets applicable standards, and any other safety, security, or other requirements. These resources are subject to change without notice. TI grants you permission to use these resources only for development of an application that uses the TI products described in the resource. Other reproduction and display of these resources is prohibited. No license is granted to any other TI intellectual property right or to any third party intellectual property right. TI disclaims responsibility for, and you will fully indemnify TI and its representatives against, any claims, damages, costs, losses, and liabilities arising out of your use of these resources.

TI's products are provided subject to TI's Terms of Sale (www.ti.com/legal/termsofsale.html) or other applicable terms available either on ti.com or provided in conjunction with such TI products. TI's provision of these resources does not expand or otherwise alter TI's applicable warranties or warranty disclaimers for TI products.

Mailing Address: Texas Instruments, Post Office Box 655303, Dallas, Texas 75265
Copyright © 2018, Texas Instruments Incorporated

Looking for pricing, stock, or lifecycle information?

Click below to explore more details on WIN SOURCE:

 [View LM2599SX-ADJ/NOPB on WIN SOURCE](#)

 [Texas Instruments](#) Information

Optimize Your Supply Chain with WIN SOURCE Solutions

-  Global Sourcing Solution
-  Obsolete Management
-  Cost Control Management
-  Shortage Management
-  Alternative Solution
-  Excess Inventory Management