



**THE DATASHEET OF
LM2679SX-5.0/NOPB**



LM2679 SIMPLE SWITCHER® 5-A Step-Down Voltage Regulator With Adjustable Current Limit

1 Features

- Efficiency Up to 92%
- Simple and Easy to Design Using Off-The-Shelf External Components
- Resistor Programmable Peak Current Limit Over a Range of 3 A to 7 A
- 120-mΩ DMOS Output Switch
- 3.3-V, 5-V, 12-V Fixed Output and Adjustable (1.2 V to 37 V) Versions
- ±2% Maximum Output Tolerance Over Full Line and Load Conditions
- Wide Input Voltage Range: 8 V to 40 V
- 260-kHz Fixed Frequency Internal Oscillator
- Soft-Start Capability
- –40 to 125°C Operating Junction Temperature Range

2 Applications

- Simple-to-Design, High Efficiency (>90%) Step-Down Switching Regulators
- Efficient System Preregulator for Linear Voltage Regulators
- Battery Chargers

3 Description

The LM2679 series of regulators are monolithic integrated circuits which provide all of the active functions for a step-down (buck) switching regulator capable of driving up to 5-A loads with excellent line and load regulation characteristics. High efficiency (>90%) is obtained through the use of a low ON-resistance DMOS power switch. The series consists of fixed output voltages of 3.3 V, 5 V, and 12 V and an adjustable output version.

The SIMPLE SWITCHER® concept provides for a complete design using a minimum number of external components. A high fixed frequency oscillator (260 kHz) allows the use of physically smaller sized components. A family of standard inductors for use with the LM2679 are available from several manufacturers to greatly simplify the design process.

Other features include the ability to reduce the input surge current at power on by adding a soft-start timing capacitor to gradually turn on the regulator. The LM2679 series also has built-in thermal shutdown and resistor programmable current limit of the power MOSFET switch to protect the device and load circuitry under fault conditions. The output voltage is specified to a ±2% tolerance. The clock frequency is controlled to within a ±11% tolerance.

Device Information⁽¹⁾

PART NUMBER	PACKAGE	BODY SIZE (NOM)
LM2679	TO-263 (7)	10.10 mm × 8.89 mm
	TO-220 (7)	14.986 mm × 10.16 mm
	VSON (14)	6.00 mm × 5.00 mm

(1) For all available packages, see the orderable addendum at the end of the data sheet.

Typical Application

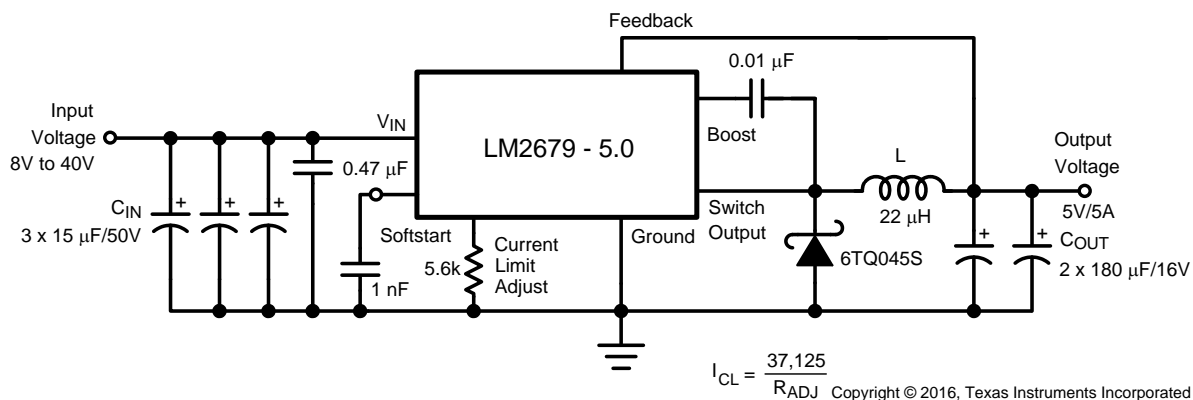

Table of Contents

1 Features	1	7.3 Feature Description	9
2 Applications	1	7.4 Device Functional Modes	10
3 Description	1	8 Application and Implementation	11
4 Revision History	2	8.1 Application Information	11
5 Pin Configuration and Functions	3	8.2 Typical Application	14
6 Specification	4	9 Power Supply Recommendations	26
6.1 Absolute Maximum Ratings	4	10 Layout	26
6.2 ESD Ratings	4	10.1 Layout Guidelines	26
6.3 Recommended Operating Conditions	4	10.2 Layout Example	27
6.4 Thermal Information	5	11 Device and Documentation Support	28
6.5 Electrical Characteristics – 3.3 V	5	11.1 Related Documentation	28
6.6 Electrical Characteristics – 5 V	5	11.2 Receiving Notification of Documentation Updates	28
6.7 Electrical Characteristics – 12 V	6	11.3 Community Resources	28
6.8 Electrical Characteristics – Adjustable	6	11.4 Trademarks	28
6.9 Electrical Characteristics – All Output Voltage Versions	6	11.5 Electrostatic Discharge Caution	28
6.10 Typical Characteristics	7	11.6 Glossary	28
7 Detailed Description	9	12 Mechanical, Packaging, and Orderable Information	28
7.1 Overview	9	12.1 VSON Package Devices	28
7.2 Functional Block Diagram	9		

4 Revision History

NOTE: Page numbers for previous revisions may differ from page numbers in the current version.

Changes from Revision N (April 2013) to Revision O	Page
<ul style="list-style-type: none"> Added <i>ESD Ratings</i> table, <i>Feature Description</i> section, <i>Device Functional Modes</i>, <i>Application and Implementation</i> section, <i>Power Supply Recommendations</i> section, <i>Layout</i> section, <i>Device and Documentation Support</i> section, and <i>Mechanical, Packaging, and Orderable Information</i> section. 	1
<ul style="list-style-type: none"> Removed all references to Computer Design Software LM267X Made Simple (Version 6.0) 	1

Changes from Revision M (April 2013) to Revision N	Page
<ul style="list-style-type: none"> Changed layout of National Data Sheet to TI format 	15

5 Pin Configuration and Functions

**KTW Package
7-Pin TO-263
Top View**

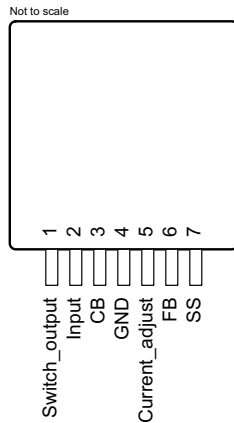

**NDZ Package
7-Pin TO-220
Top View**

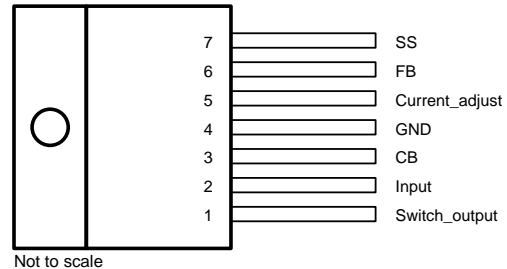

**NHM Package
14-Pin VSON
Top View**

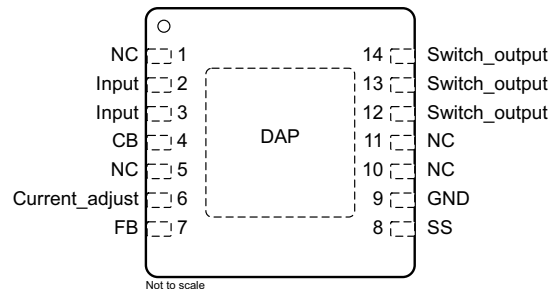

Connect DAP to pin 9

Pin Functions

NAME	PIN		I/O	DESCRIPTION
	TO-263, TO-220	VSON		
Switch output	1	12, 13, 14	O	Source pin of the internal high side FET. This is a switching node. Attached this pin to an inductor and the cathode of the external diode.
Input	2	2, 3	I	Supply input pin to collector pin of high side FET. Connect to power supply and input bypass capacitors CIN. Path from VIN pin to high frequency bypass CIN and GND must be as short as possible.
CB	3	4	I	Boot-strap capacitor connection for high-side driver. Connect a high quality 100-nF capacitor from CB to VSW pin.
GND	4	9	—	Power ground pins. Connect to system ground. Ground pins of CIN and COUT. Path to CIN must be as short as possible.
Current adjust	5	6	I	Current limit adjust pin. Connect a resistor from this pin to GND to set the current limit of the part.
FB	6	7	I	Feedback sense input pin. Connect to the midpoint of feedback divider to set VOUT for adjustable version or connect this pin directly to the output capacitor for a fixed output version.
SS	7	8	I	Soft-start pin. Connect a capacitor from this pin to GND to control the output voltage ramp. If the feature not desired, the pin can be left floating
NC	—	1, 5, 10, 11	—	No connect pins

6 Specification

6.1 Absolute Maximum Ratings

over operating free-air temperature range (unless otherwise noted)⁽¹⁾⁽²⁾

		MIN	MAX	UNIT
Input supply voltage			45	V
Soft-start pin voltage		-0.1	6	V
Switch voltage to ground ⁽³⁾		-1	V_{IN}	V
Boost pin voltage			$V_{SW} + 8\text{ V}$	V
Feedback pin voltage		-0.3	14	V
Power dissipation		Internally limited		
Soldering temperature	Wave (4 s)		260	°C
	Infrared (10 s)		240	
	Vapor phase (75 s)		219	
Storage Temperature, T_{stg}		-65	150	°C

- (1) Stresses beyond those listed under *Absolute Maximum Ratings* may cause permanent damage to the device. These are stress ratings only, which do not imply functional operation of the device at these or any other conditions beyond those indicated under *Recommended Operating Conditions*. Exposure to absolute-maximum-rated conditions for extended periods may affect device reliability.
- (2) If Military/Aerospace specified devices are required, please contact the Texas Instruments Sales Office/Distributors for availability and specifications.
- (3) The absolute maximum specification of the switch voltage to ground applies to DC voltage. An extended negative voltage limit of -10 V applies to a pulse of up to 20 ns, -6 V of 60 ns and -3 V of up to 100 ns.

6.2 ESD Ratings

		VALUE	UNIT
$V_{(ESD)}$	Electrostatic discharge	Human-body model (HBM), per ANSI/ESDA/JEDEC JS-001 ⁽¹⁾⁽²⁾	±2000 V

- (1) JEDEC document JEP155 states that 500-V HBM allows safe manufacturing with a standard ESD control process.
- (2) ESD was applied using the human-body model, a 100-pF capacitor discharged through a 1.5-k Ω resistor into each pin.

6.3 Recommended Operating Conditions

		MIN	MAX	UNIT
Supply voltage		8	40	V
Junction temperature, T_J		-40	125	°C

6.4 Thermal Information

THERMAL METRIC ⁽¹⁾		LM2679			UNIT	
		NDZ (TO-220)	KTW (TO-263)	NHM (VSON)		
		7 PINS	7 PINS	14 PINS		
R _{θJA}	Junction-to-ambient thermal resistance	See ⁽²⁾	65	—	—	°C/W
	See ⁽³⁾	45	—	—		
	See ⁽⁴⁾	—	56	—		
	See ⁽⁵⁾	—	35	—		
	See ⁽⁶⁾	—	26	—		
	See ⁽⁷⁾	—	—	55		
See ⁽⁸⁾	—	—	29			
R _{θJC(top)}	Junction-to-case (top) thermal resistance	2	2	—	°C/W	

- (1) For more information about traditional and new thermal metrics, see the [Semiconductor and IC Package Thermal Metrics](#) application report.
- (2) Junction to ambient thermal resistance (no external heat sink) for the 7-lead TO-220 package mounted vertically, with ½ inch leads in a socket, or on a PCB with minimum copper area.
- (3) Junction to ambient thermal resistance (no external heat sink) for the 7-lead TO-220 package mounted vertically, with ½ inch leads soldered to a PCB containing approximately 4 square inches of (1 oz.) copper area surrounding the leads.
- (4) Junction to ambient thermal resistance for the 7-lead DDPAK mounted horizontally against a PCB area of 0.136 square inches (the same size as the DDPAK package) of 1 oz. (0.0014 in. thick) copper.
- (5) Junction to ambient thermal resistance for the 7-lead DDPAK mounted horizontally against a PCB area of 0.4896 square inches (3.6 times the area of the DDPAK package) of 1 oz. (0.0014 in. thick) copper.
- (6) Junction to ambient thermal resistance for the 7-lead DDPAK mounted horizontally against a PCB copper area of 1.0064 square inches (7.4 times the area of the DDPAK 3 package) of 1 oz. (0.0014 in. thick) copper. Additional copper area reduces thermal resistance further.
- (7) Junction to ambient thermal resistance for the 14-lead VSON mounted on a PCB copper area equal to the die attach paddle.
- (8) Junction to ambient thermal resistance for the 14-lead VSON mounted on a PCB copper area using 12 vias to a second layer of copper equal to die attach paddle. Additional copper area reduces thermal resistance further. For layout recommendations, see [AN-1187 Leadless Leadframe Package \(LLP\)](#).

6.5 Electrical Characteristics – 3.3 V

Specifications apply for T_A = T_J = 25°C and R_{ADJ} = 5.6 kΩ (unless otherwise noted).

PARAMETER	TEST CONDITIONS	MIN ⁽¹⁾	TYP ⁽²⁾	MAX ⁽¹⁾	UNIT	
V _{OUT}	Output voltage V _{IN} = 8 V to 40 V, 100 mA ≤ I _{OUT} ≤ 5 A	T _J = 25°C	3.234	3.3	3.366	V
		T _J = –40°C to 125°C	3.201		3.399	
η	Efficiency V _{IN} = 12 V, I _{LOAD} = 5 A		82%			

- (1) All room temperature limits are 100% tested during production with T_A = T_J = 25°C. All limits at temperature extremes are specified through correlation using standard Quality Control (SQC) methods. All limits are used to calculate Average Outgoing Quality Level (AOQL).
- (2) Typical values are determined with T_A = T_J = 25°C and represent the most likely norm.

6.6 Electrical Characteristics – 5 V

Specifications apply for T_A = T_J = 25°C and R_{ADJ} = 5.6 kΩ (unless otherwise noted).

PARAMETER	TEST CONDITIONS	MIN ⁽¹⁾	TYP ⁽²⁾	MAX ⁽¹⁾	UNIT	
V _{OUT}	Output voltage V _{IN} = 8 V to 40 V, 100 mA ≤ I _{OUT} ≤ 5 A	T _J = 25°C	4.9	5	5.1	V
		T _J = –40°C to 125°C	4.85		5.15	
η	Efficiency V _{IN} = 12 V, I _{LOAD} = 5 A		84%			

- (1) All room temperature limits are 100% tested during production with T_A = T_J = 25°C. All limits at temperature extremes are specified through correlation using standard Quality Control (SQC) methods. All limits are used to calculate Average Outgoing Quality Level (AOQL).
- (2) Typical values are determined with T_A = T_J = 25°C and represent the most likely norm.

6.7 Electrical Characteristics – 12 V

Specifications apply for $T_A = T_J = 25^\circ\text{C}$ and $R_{ADJ} = 5.6\text{ k}\Omega$ (unless otherwise noted).

PARAMETER		TEST CONDITIONS		MIN ⁽¹⁾	TYP ⁽²⁾	MAX ⁽¹⁾	UNIT
V_{OUT}	Output voltage	$V_{IN} = 15\text{ V to }40\text{ V}$, $100\text{ mA} \leq I_{OUT} \leq 5\text{ A}$	$T_J = 25^\circ\text{C}$	11.76	12	12.24	V
			$T_J = -40^\circ\text{C to }125^\circ\text{C}$	11.64		12.36	
η	Efficiency	$V_{IN} = 24\text{ V}$, $I_{LOAD} = 5\text{ A}$		92%			

- (1) All room temperature limits are 100% tested during production with $T_A = T_J = 25^\circ\text{C}$. All limits at temperature extremes are specified through correlation using standard Quality Control (SQC) methods. All limits are used to calculate Average Outgoing Quality Level (AOQL).
- (2) Typical values are determined with $T_A = T_J = 25^\circ\text{C}$ and represent the most likely norm.

6.8 Electrical Characteristics – Adjustable

Specifications apply for $T_A = T_J = 25^\circ\text{C}$ and $R_{ADJ} = 5.6\text{ k}\Omega$ (unless otherwise noted).

PARAMETER		TEST CONDITIONS		MIN ⁽¹⁾	TYP ⁽²⁾	MAX ⁽¹⁾	UNIT
V_{FB}	Feedback voltage	$V_{IN} = 8\text{ V to }40\text{ V}$, $100\text{ mA} \leq I_{OUT} \leq 5\text{ A}$, V_{OUT} programmed for 5 V	$T_J = 25^\circ\text{C}$	1.186	1.21	1.234	V
			$T_J = -40^\circ\text{C to }125^\circ\text{C}$	1.174		1.246	
η	Efficiency	$V_{IN} = 12\text{ V}$, $I_{LOAD} = 5\text{ A}$		84%			

- (1) All room temperature limits are 100% tested during production with $T_A = T_J = 25^\circ\text{C}$. All limits at temperature extremes are specified through correlation using standard Quality Control (SQC) methods. All limits are used to calculate Average Outgoing Quality Level (AOQL).
- (2) Typical values are determined with $T_A = T_J = 25^\circ\text{C}$ and represent the most likely norm.

6.9 Electrical Characteristics – All Output Voltage Versions

Specifications are for $T_A = T_J = 25^\circ\text{C}$, $V_{IN} = 12\text{ V}$ for the 3.3 V, 5-V, and adjustable versions, and $V_{IN} = 24\text{ V}$ for the 12-V version (unless otherwise specified).

PARAMETER		TEST CONDITIONS		MIN	TYP	MAX	UNIT
I_Q	Quiescent current	$V_{FEEDBACK} = 8\text{ V}$ for 3.3-V, 5-V, and adjustable versions, $V_{FEEDBACK} = 15\text{ V}$ for 12-V version			4.2	6	mA
V_{ADJ}	Current limit adjust voltage	$T_J = 25^\circ\text{C}$		1.181	1.21	1.229	V
		$T_J = -40^\circ\text{C to }125^\circ\text{C}$		1.169		1.246	
I_{CL}	Current limit	$R_{ADJ} = 5.6\text{ k}\Omega^{(1)}$	$T_J = 25^\circ\text{C}$	5.5	6.3	7.6	A
			$T_J = -40^\circ\text{C to }125^\circ\text{C}$	5.3		8.1	
I_L	Output leakage current	$V_{IN} = 40\text{ V}$, soft-start pin = 0 V	$V_{SWITCH} = 0\text{ V}$		1	1.5	mA
			$V_{SWITCH} = -1\text{ V}$		6	15	
$R_{DS(ON)}$	Switch ON-resistance	$I_{SWITCH} = 5\text{ A}$	$T_J = 25^\circ\text{C}$		0.12	0.14	Ω
			$T_J = -40^\circ\text{C to }125^\circ\text{C}$			0.225	
f_O	Oscillator frequency	Measured at switch pin	$T_J = 25^\circ\text{C}$		260		kHz
			$T_J = -40^\circ\text{C to }125^\circ\text{C}$	225		280	
D	Duty cycle	Maximum duty cycle			91%		
		Minimum duty cycle			0%		
I_{BIAS}	Feedback bias current	$V_{FEEDBACK} = 1.3\text{ V}$ (adjustable version only)			85		nA
V_{SFST}	Soft-start threshold voltage	$T_J = 25^\circ\text{C}$			0.63		V
		$T_J = -40^\circ\text{C to }125^\circ\text{C}$		0.53		0.74	
I_{SFST}	Soft-start pin current	Soft-start pin = 0 V	$T_J = 25^\circ\text{C}$		3.7		μA
			$T_J = -40^\circ\text{C to }125^\circ\text{C}$			6.9	

- (1) The peak switch current limit is determined by the following relationship: $I_{CL} = 37,125 / R_{ADJ}$

6.10 Typical Characteristics

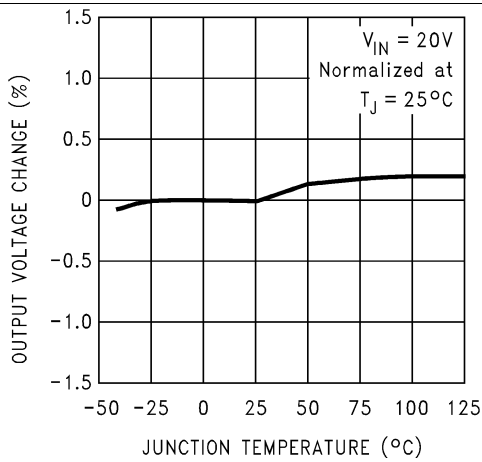

Figure 1. Normalized Output Voltage

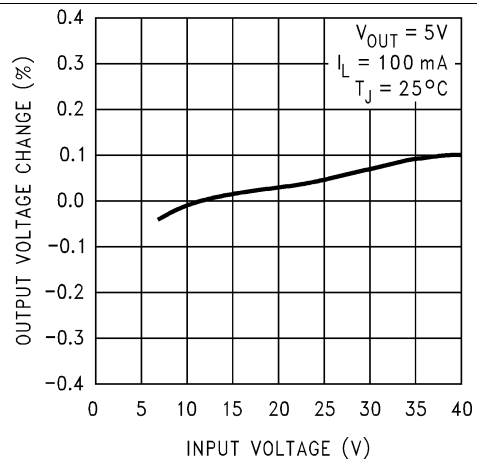

Figure 2. Line Regulation

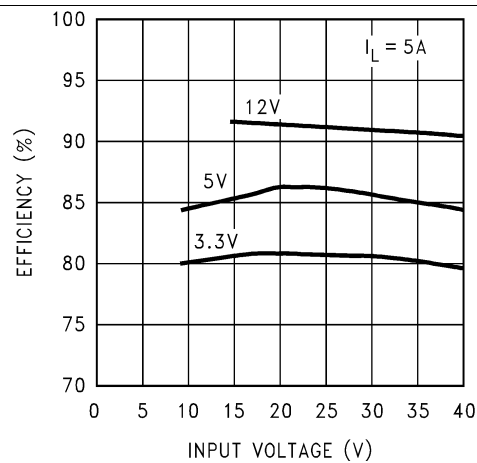

Figure 3. Efficiency vs Input Voltage

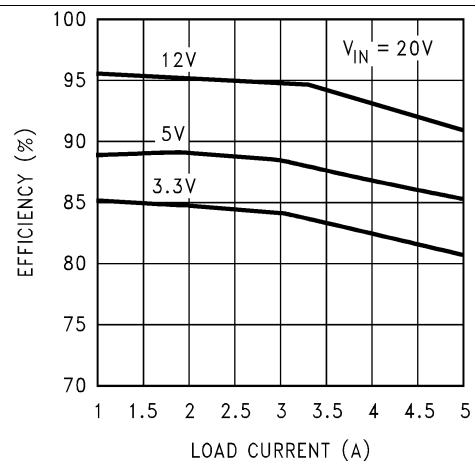

Figure 4. Efficiency vs I_{LOAD}

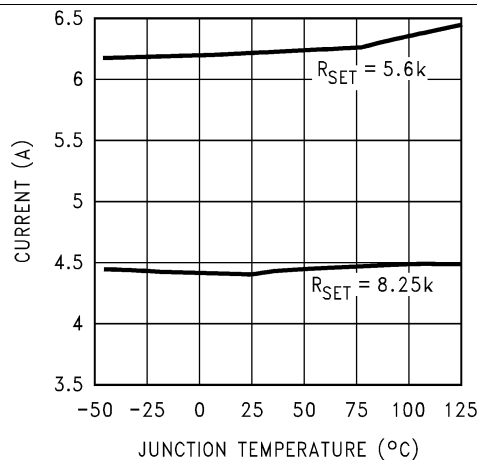

Figure 5. Switch Current Limit

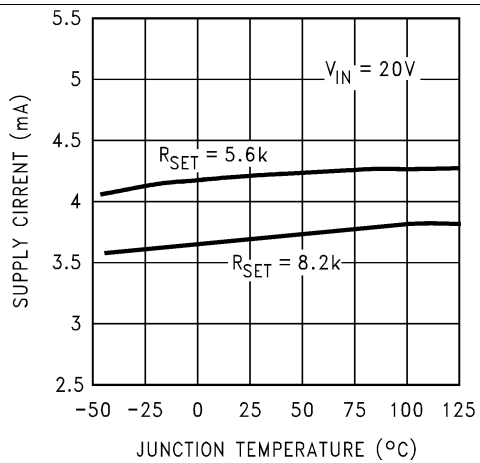

Figure 6. Operating Quiescent Current

Typical Characteristics (continued)

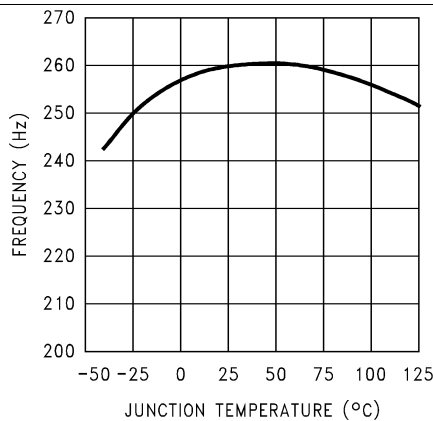

Figure 7. Switching Frequency

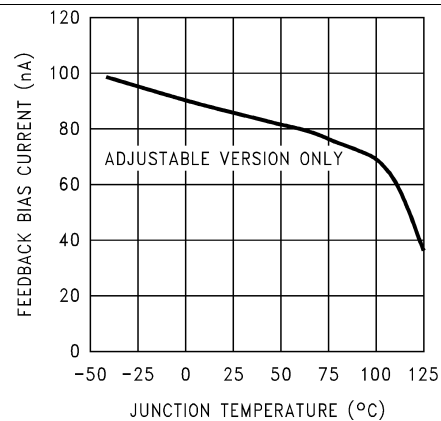
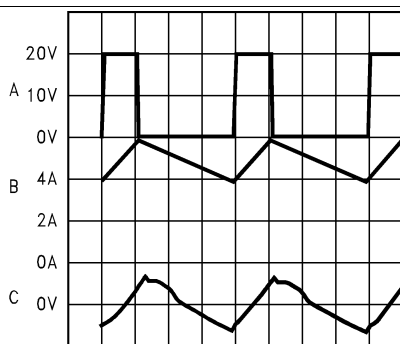

Figure 8. Feedback Pin Bias Current



1 μ sec/Div

Continuous Mode Switching Waveforms $V_{IN} = 20\text{ V}$, $V_{OUT} = 5\text{ V}$, $I_{LOAD} = 5\text{ A}$, $L = 10\text{ }\mu\text{H}$, $C_{OUT} = 400\text{ }\mu\text{F}$, $C_{OUTESR} = 13\text{ m}\Omega$
 A. V_{SW} pin voltage, 10 V/div
 B. Inductor current, 2 A/div
 C. Output ripple voltage, 20 mV/div AC-coupled

Figure 9. Horizontal Time Base: 1 μ s/div

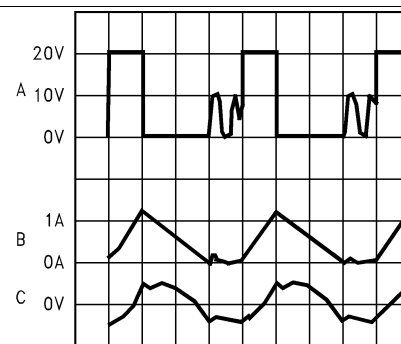

1 μ sec/Div

Discontinuous Mode Switching Waveforms $V_{IN} = 20\text{ V}$, $V_{OUT} = 5\text{ V}$, $I_{LOAD} = 500\text{ mA}$, $L = 10\text{ }\mu\text{H}$, $C_{OUT} = 400\text{ }\mu\text{F}$, $C_{OUTESR} = 13\text{ m}\Omega$
 A. V_{SW} pin voltage, 10 V/div
 B. Inductor current, 1 A/div
 C. Output ripple voltage, 20 mV/div AC-coupled

Figure 10. Horizontal Time Base: 1 μ s/div

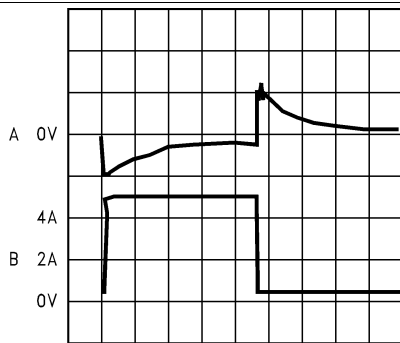

100 μ sec/Div

Load Transient Response for Continuous Mode $V_{IN} = 20\text{ V}$, $V_{OUT} = 5\text{ V}$, $L = 10\text{ }\mu\text{H}$, $C_{OUT} = 400\text{ }\mu\text{F}$, $C_{OUTESR} = 13\text{ m}\Omega$
 A. Output voltage, 100 mV/div, AC-coupled
 B. Load current: 500-mA to 5-A load pulse

Figure 11. Horizontal Time Base: 100 μ s/div

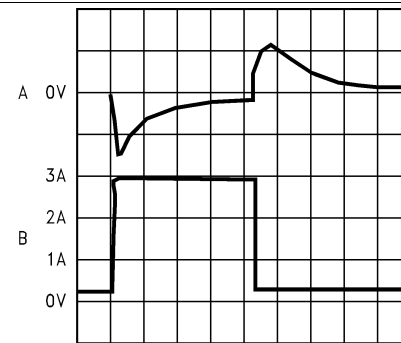

200 μ sec/Div

Load Transient Response for Discontinuous Mode $V_{IN} = 20\text{ V}$, $V_{OUT} = 5\text{ V}$, $L = 10\text{ }\mu\text{H}$, $C_{OUT} = 400\text{ }\mu\text{F}$, $C_{OUTESR} = 13\text{ m}\Omega$
 A. Output voltage, 100 mV/div, AC-coupled
 B. Load current: 200-mA to 3-A load pulse

Figure 12. Horizontal Time Base: 200 μ s/div

7 Detailed Description

7.1 Overview

The LM2679 provides all of the active functions required for a step-down (buck) switching regulator. The internal power switch is a DMOS power MOSFET to provide power supply designs with high current capability, up to 5 A, and highly efficient operation.

The LM2679 is part of the SIMPLE SWITCHER[®] family of power converters. A complete design uses a minimum number of external components, which have been predetermined from a variety of manufacturers. The software is provided free of charge and can be downloaded from Texas Instruments Internet site: www.ti.com.

7.2 Functional Block Diagram

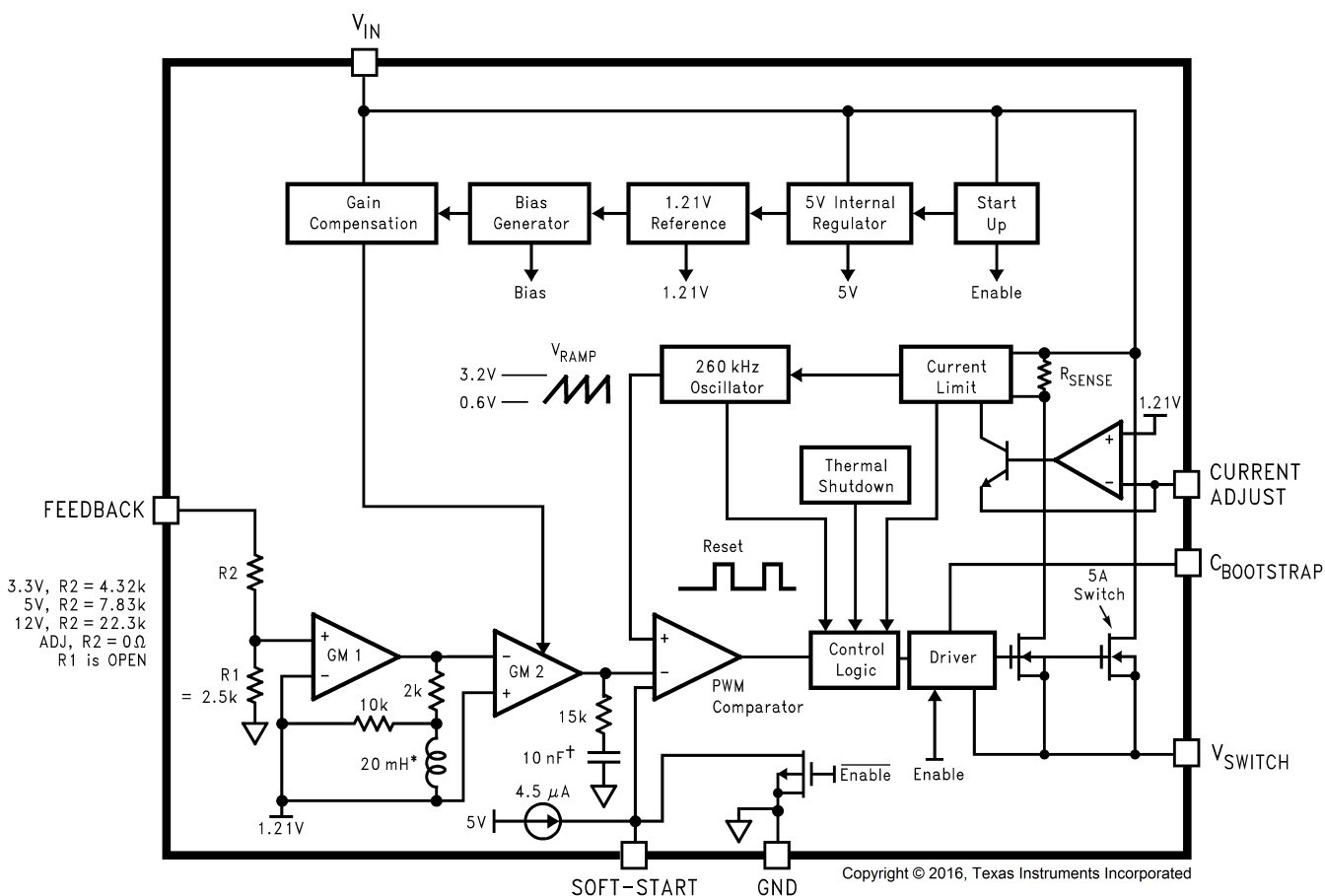

7.3 Feature Description

7.3.1 Switch Output

This is the output of a power MOSFET switch connected directly to the input voltage. The switch provides energy to an inductor, an output capacitor and the load circuitry under control of an internal pulse-width-modulator (PWM). The PWM controller is internally clocked by a fixed 260-kHz oscillator. In a standard step-down application the duty cycle (Time ON/Time OFF) of the power switch is proportional to the ratio of the power supply output voltage to the input voltage. The voltage on pin 1 switches between V_{IN} (switch ON) and below ground by the voltage drop of the external Schottky diode (switch OFF).

Feature Description (continued)

7.3.2 Input

The input voltage for the power supply is connected to pin 2. In addition to providing energy to the load the input voltage also provides bias for the internal circuitry of the LM2679. For ensured performance the input voltage must be in the range of 8 V to 40 V. For best performance of the power supply the input pin must always be bypassed with an input capacitor placed close to pin 2.

7.3.3 C Boost

A capacitor must be connected from pin 3 to the switch output, pin 1. This capacitor boosts the gate drive to the internal MOSFET above V_{IN} to fully turn it ON. This minimizes conduction losses in the power switch to maintain high efficiency. The recommended value for C Boost is 0.01 μ F.

7.3.4 Ground

This is the ground reference connection for all components in the power supply. In fast-switching, high-current applications such as those implemented with the LM2679, TI recommends that a broad ground plane be used to minimize signal coupling throughout the circuit.

7.3.5 Current Adjust

A key feature of the LM2679 is the ability to tailor the peak switch current limit to a level required by a particular application. This alleviates the requirement to use external components that must be physically sized to accommodate current levels (under shorted output conditions for example) that may be much higher than the normal circuit operating current requirements.

A resistor connected from pin 5 to ground establishes a current ($I_{(pin\ 5)} = 1.2\text{ V} / R_{ADJ}$) that sets the peak current through the power switch. The maximum switch current is fixed at a level of $37,125 / R_{ADJ}$.

7.3.6 Feedback

This is the input to a two-stage high gain amplifier, which drives the PWM controller. It is necessary to connect pin 6 to the actual output of the power supply to set the DC output voltage. For the fixed output devices (3.3-V, 5-V and 12-V outputs), a direct wire connection to the output is all that is required as internal gain setting resistors are provided inside the LM2679. For the adjustable output version two external resistors are required to set the DC output voltage. For stable operation of the power supply it is important to prevent coupling of any inductor flux to the feedback input.

7.4 Device Functional Modes

7.4.1 Soft Start

A capacitor connected from pin 7 to ground allows for a slow turnon of the switching regulator. The capacitor sets a time delay to gradually increase the duty cycle of the internal power switch. This can significantly reduce the amount of surge current required from the input supply during an abrupt application of the input voltage. If soft start is not required this pin must be left open circuited. See [Soft-Start Capacitor, \$C_{SS}\$](#) for further information regarding soft-start capacitor values.

8 Application and Implementation

NOTE

Information in the following applications sections is not part of the TI component specification, and TI does not warrant its accuracy or completeness. TI's customers are responsible for determining suitability of components for their purposes. Customers should validate and test their design implementation to confirm system functionality.

8.1 Application Information

8.1.1 Design Considerations

Power supply design using the LM2679 is greatly simplified by using recommended external components. A wide range of inductors, capacitors and Schottky diodes from several manufacturers have been evaluated for use in designs that cover the full range of capabilities (input voltage, output voltage, and load current) of the LM2679. A simple design procedure using nomographs and component tables provided in this data sheet leads to a working design with very little effort.

The individual components from the various manufacturers called out for use are still just a small sample of the vast array of components available in the industry. While these components are recommended, they are not exclusively the only components for use in a design. After a close comparison of component specifications, equivalent devices from other manufacturers could be substituted for use in an application.

Important considerations for each external component and an explanation of how the nomographs and selection tables were developed follows.

8.1.2 Inductor

The inductor is the key component in a switching regulator. For efficiency the inductor stores energy during the switch ON time and then transfers energy to the load while the switch is OFF.

Nomographs are used to select the inductance value required for a given set of operating conditions. The nomographs assume that the circuit is operating in continuous mode (the current flowing through the inductor never falls to zero). The magnitude of inductance is selected to maintain a maximum ripple current of 30% of the maximum load current. If the ripple current exceeds this 30% limit the next larger value is selected.

The inductors offered have been specifically manufactured to provide proper operation under all operating conditions of input and output voltage and load current. Several part types are offered for a given amount of inductance. Both surface mount and through-hole devices are available. The inductors from each of the three manufacturers have unique characteristics:

- Renco: ferrite stick core inductors; benefits are typically lowest cost and can withstand ripple and transient peak currents above the rated value. These inductors have an external magnetic field, which may generate EMI.
- Pulse Engineering: powdered iron toroid core inductors; these also can withstand higher than rated currents and, being toroid inductors, have low EMI.
- Coilcraft: ferrite drum core inductors; these are the smallest physical size inductors and are available only as surface mount components. These inductors also generate EMI but less than stick inductors.

8.1.3 Output Capacitor

The output capacitor acts to smooth the DC output voltage and also provides energy storage. Selection of an output capacitor, with an associated equivalent series resistance (ESR), impacts both the amount of output ripple voltage and stability of the control loop.

The output ripple voltage of the power supply is the product of the capacitor ESR and the inductor ripple current. The capacitor types recommended in the tables were selected for having low ESR ratings.

In addition, both surface mount tantalum capacitors and through-hole aluminum electrolytic capacitors are offered as solutions.

Application Information (continued)

Impacting frequency stability of the overall control loop, the output capacitance, in conjunction with the inductor, creates a double pole inside the feedback loop. In addition the capacitance and the ESR value create a zero. These frequency response effects together with the internal frequency compensation circuitry of the LM2679 modify the gain and phase shift of the closed-loop system.

As a general rule for stable switching regulator circuits it is desired to have the unity gain bandwidth of the circuit to be limited to no more than one-sixth of the controller switching frequency. With the fixed 26-kHz switching frequency of the LM2679, the output capacitor is selected to provide a unity gain bandwidth of 40 kHz maximum. Each recommended capacitor value has been chosen to achieve this result.

In some cases multiple capacitors are required either to reduce the ESR of the output capacitor, to minimize output ripple (a ripple voltage of 1% of V_{OUT} or less is the assumed performance condition), or to increase the output capacitance to reduce the closed loop unity gain bandwidth (to less than 40 kHz). When parallel combinations of capacitors are required it has been assumed that each capacitor is the exact same part type.

The RMS current and working voltage (WV) ratings of the output capacitor are also important considerations. In a typical step-down switching regulator, the inductor ripple current (set to be no more than 30% of the maximum load current by the inductor selection) is the current that flows through the output capacitor. The capacitor RMS current rating must be greater than this ripple current. The voltage rating of the output capacitor must be greater than 1.3 times the maximum output voltage of the power supply. If operation of the system at elevated temperatures is required, the capacitor voltage rating may be de-rated to less than the nominal room temperature rating. Careful inspection of the manufacturer's specification for de-rating of working voltage with temperature is important.

8.1.4 Input Capacitor

Fast changing currents in high current switching regulators place a significant dynamic load on the unregulated power source. An input capacitor helps to provide additional current to the power supply as well as smooth out input voltage variations.

Like the output capacitor, the key specifications for the input capacitor are RMS current rating and working voltage. The RMS current flowing through the input capacitor is equal to one-half of the maximum DC load current so the capacitor must be rated to handle this. Paralleling multiple capacitors proportionally increases the current rating of the total capacitance. The voltage rating must also be selected to be 1.3 times the maximum input voltage. Depending on the unregulated input power source, under light load conditions the maximum input voltage could be significantly higher than normal operation. Consider this when selecting an input capacitor.

The input capacitor must be placed very close to the input pin of the LM2679. Due to relative high current operation with fast transient changes, the series inductance of input connecting wires or PCB traces can create ringing signals at the input terminal which could possibly propagate to the output or other parts of the circuitry. It may be necessary in some designs to add a small valued (0.1- μ F to 0.47- μ F) ceramic type capacitor in parallel with the input capacitor to prevent or minimize any ringing.

8.1.5 Catch Diode

When the power switch in the LM2679 turns OFF, the current through the inductor continues to flow. The path for this current is through the diode connected between the switch output and ground. This forward biased diode clamps the switch output to a voltage less than ground. This negative voltage must be greater than -1 V so a low voltage drop (particularly at high current levels) Schottky diode is recommended. Total efficiency of the entire power supply is significantly impacted by the power lost in the output catch diode. The average current through the catch diode is dependent on the switch duty cycle (D) and is equal to the load current times (1-D). Use of a diode rated for much higher current than is required by the actual application helps to minimize the voltage drop and power loss in the diode.

During the switch ON time the diode is reversed biased by the input voltage. The reverse voltage rating of the diode must be at least 1.3 times greater than the maximum input voltage.

8.1.6 Boost Capacitor

The boost capacitor creates a voltage used to overdrive the gate of the internal power MOSFET. This improves efficiency by minimizing the ON-resistance of the switch and associated power loss. For all applications TI recommends a 0.01- μ F, 50-V ceramic capacitor.

Application Information (continued)

8.1.7 Adjustable Current Limit, R_{ADJ}

A key feature of the LM2679 is the ability to control the peak switch current. Without this feature the peak switch current would be internally set to 7 A or higher to accommodate 5-A load current designs. This requires that both the inductor (which could saturate with excessively high currents) and the catch diode be able to safely handle up to 7 A which would be conducted under load fault conditions.

If an application only requires a load current of 3 A or 4 A the peak switch current can be set to a limit just over the maximum load current with the addition of a single programming resistor. This allows the use of less powerful and more cost-effective inductors and diodes.

The peak switch current is equal to a factor of 37,125 divided by R_{ADJ} . A resistance of 5.6 k Ω sets the current limit to typically 6.3 A and an R_{ADJ} of 8.25 k Ω reduces the maximum current to approximately 4.4 A. For predictable control of the current limit, TI recommends keeping the peak switch current greater than 3 A. For lower current applications a 3-A switching regulator with adjustable current limit, the LM2673, is available.

When the power switch reaches the current limit threshold it is immediately turned OFF and the internal switching frequency is reduced. This extends the OFF time of the switch to prevent a steady-state high current condition. As the switch current falls below the current limit threshold, the switch turns back ON. If a load fault continues, the switch again exceeds the threshold and switch back OFF. This results in a low duty cycle pulsing of the power switch to minimize the overall fault condition power dissipation.

8.1.8 Soft-Start Capacitor, C_{SS}

This optional capacitor controls the rate at which the LM2679 starts up at power on. The capacitor is charged linearly by an internal current source. This voltage ramp gradually increases the duty cycle of the power switch until it reaches the normal operating duty cycle defined primarily by the ratio of the output voltage to the input voltage. The soft-start turnon time is programmable by the selection of C_{SS} .

The formula for selecting a soft-start capacitor is [Equation 1](#).

$$C_{SS} \cong (I_{SST} \cdot t_{SS}) / [V_{SST} + 2.6V \cdot (\frac{V_{OUT} + V_{SCHOTTKY}}{V_{IN}})]$$

where

- I_{SST} = Soft-start current (3.7 μ A typical)
 - t_{SS} = Soft-start time (from [Detailed Design Procedure](#))
 - V_{SST} = Soft-start threshold voltage (0.63 V typical)
 - V_{OUT} = Output voltage (from [Detailed Design Procedure](#))
 - $V_{SCHOTTKY}$ = Schottky diode voltage drop (0.5 V typical)
 - V_{IN} = Maximum input voltage (from [Detailed Design Procedure](#))
- (1)

If this feature is not desired, leave the soft-start pin (pin 7) open circuited.

With certain soft-start capacitor values and operating conditions, the LM2679 can exhibit an overshoot on the output voltage during turnon. Especially when starting up into no load or low load, the soft-start function may not be effective in preventing a larger voltage overshoot on the output. With larger loads or lower input voltages during start-up this effect is minimized. In particular, avoid using soft-start capacitors between 0.033 μ F and 1 μ F.

8.1.9 Additional Application Information

When the output voltage is greater than approximately 6 V, and the duty cycle at minimum input voltage is greater than approximately 50%, the designer must exercise caution in selection of the output filter components. When an application designed to these specific operating conditions is subjected to a current limit fault condition, it may be possible to observe a large hysteresis in the current limit. This can affect the output voltage of the device until the load current is reduced sufficiently to allow the current limit protection circuit to reset itself.

Under current limiting conditions, the LM267x is designed to respond in the following manner:

1. At the moment when the inductor current reaches the current limit threshold, the ON-pulse is immediately terminated. This happens for any application condition.
2. However, the current limit block is also designed to momentarily reduce the duty cycle to below 50% to avoid subharmonic oscillations, which could cause the inductor to saturate.

Application Information (continued)

3. Thereafter, once the inductor current falls below the current limit threshold, there is a small relaxation time during which the duty cycle progressively rises back above 50% to the value required to achieve regulation.

If the output capacitance is sufficiently 'arge, it may be possible that as the output tries to recover, the output capacitor charging current is large enough to repeatedly re-trigger the current limit circuit before the output has fully settled. This condition is exacerbated with higher output voltage settings because the energy requirement of the output capacitor varies as the square of the output voltage ($\frac{1}{2} CV^2$), thus requiring an increased charging current.

A simple test to determine if this condition might exist for a suspect application is to apply a short circuit across the output of the converter, and then remove the shorted output condition. In an application with properly selected external components, the output recovers smoothly.

Practical values of external components that have been experimentally found to work well under these specific operating conditions are $C_{OUT} = 47 \mu F$, $L = 22 \mu H$. It must be noted that even with these components, for a device's current limit of I_{CLIM} , the maximum load current under which the possibility of the large current limit hysteresis can be minimized is $I_{CLIM}/2$. For example, if the input is 24 V and the set output voltage is 18 V, then for a desired maximum current of 1.5 A, the current limit of the chosen switcher must be confirmed to be at least 3 A.

Under extreme overcurrent or short-circuit conditions, the LM267X employs frequency foldback in addition to the current limit. If the cycle-by-cycle inductor current increases above the current limit threshold (due to short circuit or inductor saturation for example) the switching frequency is automatically reduced to protect the IC. Frequency below 100 kHz is typical for an extreme short-circuit condition.

8.2 Typical Application

8.2.1 Typical Application for All Output Voltage Versions

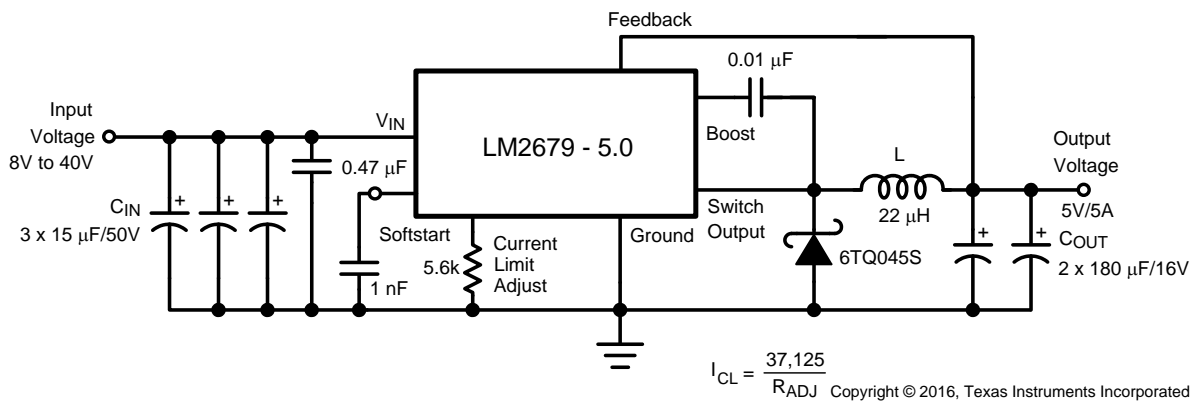

Figure 13. Typical Application Schematic

8.2.1.1 Design Requirements

Select the power supply operating conditions and the maximum output current. Then follow the procedure below to find external components for LM2679.

8.2.1.2 Detailed Design Procedure

Using the nomographs and tables in this data sheet (or use the available design software at <http://www.ti.com>) a complete step-down regulator can be designed in a few simple steps.

Step 1: Define the power supply operating conditions:

- Required output voltage
- Maximum DC input voltage
- Maximum output load current

Typical Application (continued)

Step 2: Set the output voltage by selecting a fixed output LM2679 (3.3-V, 5-V, or 12-V applications) or determine the required feedback resistors for use with the adjustable LM2679-ADJ

Step 3: Determine the inductor required by using one of the four nomographs, [Figure 14](#) through [Figure 17](#). [Table 3](#) provides a specific manufacturer and part number for the inductor.

Step 4: Using [Table 1](#) and [Table 6](#) (fixed output voltage) or [Table 9](#) and [Table 10](#) (adjustable output voltage), determine the output capacitance required for stable operation. [Table 1](#) and [Table 2](#) provide the specific capacitor type from the manufacturer of choice.

Step 5: Determine an input capacitor from [Table 7](#) and [Table 8](#) for fixed output voltage applications. Use [Table 1](#) and [Table 2](#) to find the specific capacitor type. For adjustable output circuits select a capacitor from [Table 1](#) and [Table 2](#) with a sufficient working voltage (WV) rating greater than $V_{IN\ max}$, and an RMS current rating greater than one-half the maximum load current (2 or more capacitors in parallel may be required).

Step 6: Select a diode from [Table 4](#). The current rating of the diode must be greater than $I_{LOAD\ max}$ and the reverse voltage rating must be greater than $V_{IN\ max}$.

Step 7: Include a 0.01- μ F, 50-V capacitor for C_{BOOST} in the design and then determine the value of a soft-start capacitor if desired.

Step 8: Define a value for R_{ADJ} to set the peak switch current limit to be at least 20% greater than $I_{OUT\ max}$ to allow for at least 30% inductor ripple current ($\pm 15\%$ of I_{OUT}). For designs that must operate over the full temperature range the switch current limit must be set to at least 50% greater than $I_{OUT\ max}$ ($1.5 \times I_{OUT\ max}$).

8.2.1.2.1 Capacitor Selection Guides

Table 1. Input and Output Capacitor Codes—Surface Mount

CAPACITOR REFERENCE CODE	SURFACE MOUNT								
	AVX TPS SERIES			SPRAGUE 594D SERIES			KEMET T495 SERIES		
	C (μ F)	WV (V)	I _{rms} (A)	C (μ F)	WV (V)	I _{rms} (A)	C (μ F)	WV (V)	I _{rms} (A)
C1	330	6.3	1.15	120	6.3	1.1	100	6.3	0.82
C2	100	10	1.1	220	6.3	1.4	220	6.3	1.1
C3	220	10	1.15	68	10	1.05	330	6.3	1.1
C4	47	16	0.89	150	10	1.35	100	10	1.1
C5	100	16	1.15	47	16	1	150	10	1.1
C6	33	20	0.77	100	16	1.3	220	10	1.1
C7	68	20	0.94	180	16	1.95	33	20	0.78
C8	22	25	0.77	47	20	1.15	47	20	0.94
C9	10	35	0.63	33	25	1.05	68	20	0.94
C10	22	35	0.66	68	25	1.6	10	35	0.63
C11	—	—	—	15	35	0.75	22	35	0.63
C12	—	—	—	33	35	1	4.7	50	0.66
C13	—	—	—	15	50	0.9	—	—	—

Table 2. Input and Output Capacitor Codes—Through Hole

CAPACITOR REFERENCE CODE	THROUGH HOLE											
	SANYO OS-CON SA SERIES			SANYO MV-GX SERIES			NICHICON PL SERIES			PANASONIC HFQ SERIES		
	C (μF)	WV (V)	I _{rms} (A)	C (μF)	WV (V)	I _{rms} (A)	C (μF)	WV (V)	I _{rms} (A)	C (μF)	WV (V)	I _{rms} (A)
C1	47	6.3	1	1000	6.3	0.8	680	10	0.8	82	35	0.4
C2	150	6.3	1.95	270	16	0.6	820	10	0.98	120	35	0.44
C3	330	6.3	2.45	470	16	0.75	1000	10	1.06	220	35	0.76
C4	100	10	1.87	560	16	0.95	1200	10	1.28	330	35	1.01
C5	220	10	2.36	820	16	1.25	2200	10	1.71	560	35	1.4
C6	33	16	0.96	1000	16	1.3	3300	10	2.18	820	35	1.62
C7	100	16	1.92	150	35	0.65	3900	10	2.36	1000	35	1.73
C8	150	16	2.28	470	35	1.3	6800	10	2.68	2200	35	2.8
C9	100	20	2.25	680	35	1.4	180	16	0.41	56	50	0.36
C10	47	25	2.09	1000	35	1.7	270	16	0.55	100	50	0.5
C11	—	—	—	220	63	0.76	470	16	0.77	220	50	0.92
C12	—	—	—	470	63	1.2	680	16	1.02	470	50	1.44
C13	—	—	—	680	63	1.5	820	16	1.22	560	50	1.68
C14	—	—	—	1000	63	1.75	1800	16	1.88	1200	50	2.22
C15	—	—	—	—	—	—	220	25	0.63	330	63	1.42
C16	—	—	—	—	—	—	220	35	0.79	1500	63	2.51
C17	—	—	—	—	—	—	560	35	1.43	—	—	—
C18	—	—	—	—	—	—	2200	35	2.68	—	—	—
C19	—	—	—	—	—	—	150	50	0.82	—	—	—
C20	—	—	—	—	—	—	220	50	1.04	—	—	—
C21	—	—	—	—	—	—	330	50	1.3	—	—	—
C22	—	—	—	—	—	—	100	63	0.75	—	—	—
C23	—	—	—	—	—	—	390	63	1.62	—	—	—
C24	—	—	—	—	—	—	820	63	2.22	—	—	—
C25	—	—	—	—	—	—	1200	63	2.51	—	—	—

Table 3. Inductor Manufacturer Part Numbers

INDUCTOR REFERENCE NUMBER	INDUCTANCE (μH)	CURRENT (A)	RENCO		PULSE ENGINEERING		COILCRAFT
			THROUGH HOLE	SURFACE MOUNT	THROUGH HOLE	SURFACE MOUNT	SURFACE MOUNT
L23	33	1.35	RL-5471-7	RL1500-33	PE-53823	PE-53823S	DO3316-333
L24	22	1.65	RL-1283-22-43	RL1500-22	PE-53824	PE-53824S	DO3316-223
L25	15	2	RL-1283-15-43	RL1500-15	PE-53825	PE-53825S	DO3316-153
L29	100	1.41	RL-5471-4	RL-6050-100	PE-53829	PE-53829S	DO5022P-104
L30	68	1.71	RL-5471-5	RL6050-68	PE-53830	PE-53830S	DO5022P-683
L31	47	2.06	RL-5471-6	RL6050-47	PE-53831	PE-53831S	DO5022P-473
L32	33	2.46	RL-5471-7	RL6050-33	PE-53932	PE-53932S	DO5022P-333
L33	22	3.02	RL-1283-22-43	RL6050-22	PE-53933	PE-53933S	DO5022P-223
L34	15	3.65	RL-1283-15-43	—	PE-53934	PE-53934S	DO5022P-153
L38	68	2.97	RL-5472-2	—	PE-54038	PE-54038S	—
L39	47	3.57	RL-5472-3	—	PE-54039	PE-54039S	—
L40	33	4.26	RL-1283-33-43	—	PE-54040	PE-54040S	—
L41	22	5.22	RL-1283-22-43	—	PE-54041	P0841	—
L44	68	3.45	RL-5473-3	—	PE-54044	—	—
L45	10	4.47	RL-1283-10-43	—	—	P0845	DO5022P-103HC
L46	15	5.6	RL-1283-15-43	—	—	P0846	DO5022P-153HC
L47	10	5.66	RL-1283-10-43	—	—	P0847	DO5022P-103HC
L48	47	5.61	RL-1282-47-43	—	—	P0848	—
L49	33	5.61	RL-1282-33-43	—	—	P0849	—

Table 4. Schottky Diode Selection Table

REVERSE VOLTAGE (V)	SURFACE MOUNT		THROUGH HOLE	
	3 A	5 A OR MORE	3 A	5 A OR MORE
20	SK32	—	1N5820	—
	—	—	SR302	—
30	SK33	MBRD835L	1N5821	—
	30WQ03F	—	31DQ03	—
40	SK34	MBRD1545CT	1N5822	1N5825
	30BQ040	6TQ045S	MBR340	MBR745
	30WQ04F	—	31DQ04	80SQ045
	MBRS340	—	SR403	6TQ045
	MBRD340	—	—	—
50 or more	SK35	—	MBR350	—
	30WQ05F	—	31DQ05	—
	—	—	SR305	—

8.2.1.3 Application Curves

For continuous mode operation

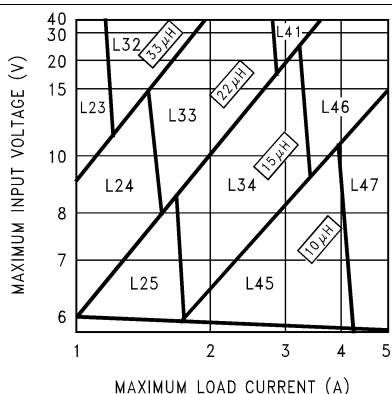

Figure 14. LM2679-3.3 V

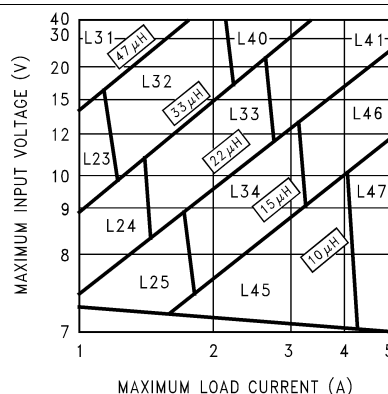

Figure 15. LM2679-5 V

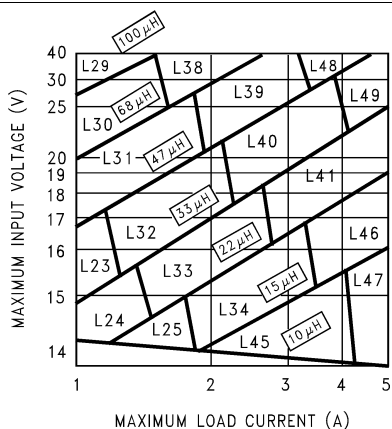

Figure 16. LM2679-12 V

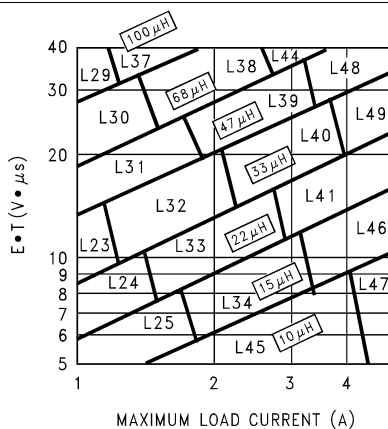

Figure 17. LM2679-Adjustable Voltage

8.2.2 Fixed Output Voltage Design Example

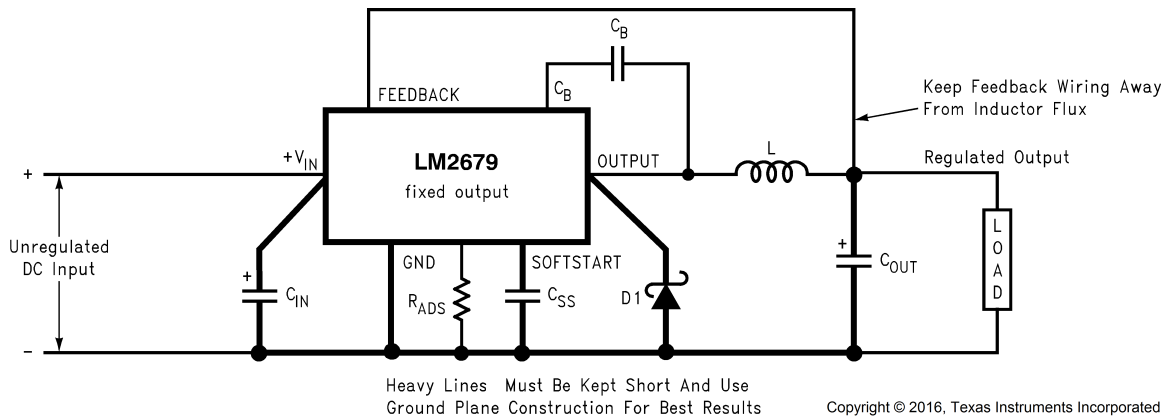

Figure 18. Basic Circuit for Fixed Output Voltage Applications

8.2.2.1 Detailed Design Procedure

A system logic power supply bus of 3.3 V is to be generated from a wall adapter which provides an unregulated DC voltage of 13 V to 16 V. The maximum load current is 4 A. A soft-start delay time of 50 ms is desired. Through-hole components are preferred.

Step 1: Operating conditions are:

- $V_{OUT} = 3.3\text{ V}$
- $V_{IN\text{ max}} = 16\text{ V}$
- $I_{LOAD\text{ max}} = 4\text{ A}$

Step 2: Select an LM2679T-3.3. The output voltage has a tolerance of $\pm 2\%$ at room temperature and $\pm 3\%$ over the full operating temperature range.

Step 3: Use the nomograph for the 3.3-V device, [Figure 14](#). The intersection of the 16 V horizontal line ($V_{IN\text{ max}}$) and the 4 A vertical line ($I_{load\text{ max}}$) indicates that L46, a 15- μH inductor, is required.

From [Table 3](#), L46 in a through-hole component is available from Renco with part number RL-1283-15-43.

Step 4: Use [Table 5](#) and [Table 6](#) to determine an output capacitor. With a 3.3-V output and a 15- μH inductor there are four through-hole output capacitor solutions with the number of same type capacitors to be paralleled and an identifying capacitor code given. [Table 1](#) and [Table 2](#) provide the actual capacitor characteristics. Any of the following choices works in the circuit:

- 2 \times 220- μF , 10-V Sanyo OS-CON (code C5)
- 2 \times 820- μF , 16-V Sanyo MV-GX (code C5)
- 1 \times 3900- μF , 10-V Nichicon PL (code C7)
- 2 \times 560- μF , 35-V Panasonic HFQ (code C5)

Step 5: Use [Table 7](#) and [Table 8](#) to select an input capacitor. With 3.3-V output and 15 μH there are three through-hole solutions. These capacitors provide a sufficient voltage rating and an RMS current rating greater than 2 A ($1/2 I_{LOAD\text{ max}}$). Again using [Table 1](#) and [Table 2](#) for specific component characteristics the following choices are suitable:

- 2 \times 680- μF , 63-V Sanyo MV-GX (code C13)
- 1 \times 1200- μF , 63-V Nichicon PL (code C25)
- 1 \times 1500- μF , 63-V Panasonic HFQ (code C16)

Step 6: From [Table 4](#), a 5-A or more Schottky diode must be selected. For through-hole components only 40-V rated diodes are indicated and 4 part types are suitable:

- 1N5825
- MBR745
- 80SQ045
- 6TQ045

Step 7: A 0.01- μF capacitor is used for C_{BOOST} . For the 50-ms soft-start delay the following parameters are to be used:

- $I_{\text{SST}} = 3.7 \mu\text{A}$
- $t_{\text{SS}} = 50 \text{ ms}$
- $V_{\text{SST}} = 0.63 \text{ V}$
- $V_{\text{OUT}} = 3.3 \text{ V}$
- $V_{\text{SCHOTTKY}} = 0.5 \text{ V}$
- $V_{\text{IN}} = 16 \text{ V}$

Using V_{IN} max ensures that the soft-start delay time is at least the desired 50 ms.

Using the formula for C_{SS} a value of 0.148 μF is determined to be required. Use of a standard value 0.22- μF capacitor produces more than sufficient soft-start delay.

Step 8: Determine a value for R_{ADJ} with [Equation 2](#) to provide a peak switch current limit of at least 4 A plus 50% or 6 A.

$$R_{\text{ADJ}} = \frac{37,125}{6\text{A}} = 6.1875 \text{ k}\Omega \quad (2)$$

Use a value of 6.2 k Ω .

8.2.2.1.1 Capacitor Selection

Table 5. Output Capacitors for Fixed Output Voltage Application—Surface Mount⁽¹⁾⁽²⁾

OUTPUT VOLTAGE (V)	INDUCTANCE (μH)	SURFACE MOUNT					
		AVX TPS SERIES		SPRAGUE 594D SERIES		KEMET T495 SERIES	
		NO.	C CODE	NO.	C CODE	NO.	C CODE
3.3	10	5	C1	5	C1	5	C2
	15	4	C1	4	C1	4	C3
	22	3	C2	2	C7	3	C4
	33	1	C1	2	C7	3	C4
5	10	4	C2	4	C6	4	C4
	15	3	C3	2	C7	3	C5
	22	3	C2	2	C7	3	C4
	33	2	C2	2	C3	2	C4
	47	2	C2	1	C7	2	C4
12	10	4	C5	3	C6	5	C9
	15	3	C5	2	C7	4	C9
	22	2	C5	2	C6	3	C8
	33	2	C5	1	C7	3	C8
	47	2	C4	1	C6	2	C8
	68	1	C5	1	C5	2	C7
	100	1	C4	1	C5	1	C8

(1) No. represents the number of identical capacitor types to be connected in parallel.

(2) C Code indicates the Capacitor Reference number in [Table 1](#) and [Table 2](#) for identifying the specific component from the manufacturer.

Table 6. Output Capacitors for Fixed Output Voltage Application—Through Hole⁽¹⁾⁽²⁾

OUTPUT VOLTAGE (V)	INDUCTANCE (μH)	THROUGH HOLE							
		SANYO OS-CON SA SERIES		SANYO MV-GX SERIES		NICHICON PL SERIES		PANASONIC HFQ SERIES	
		NO.	C CODE	NO.	C CODE	NO.	C CODE	NO.	C CODE
3.3	10	2	C5	2	C6	1	C8	2	C6
	15	2	C5	2	C5	1	C7	2	C5
	22	1	C5	1	C10	1	C5	1	C7
	33	1	C5	1	C10	1	C5	1	C7
5	10	2	C4	2	C5	1	C6	2	C5
	15	1	C5	1	C10	1	C5	1	C7
	22	1	C5	1	C9	1	C5	1	C5
	33	1	C4	1	C5	1	C4	1	C4
	47	1	C4	1	C4	1	C2	2	C4
12	10	2	C7	1	C10	1	C14	2	C4
	15	1	C8	1	C6	1	C17	1	C5
	22	1	C7	1	C5	1	C13	1	C5
	33	1	C7	1	C4	1	C12	1	C4
	47	1	C7	1	C3	1	C11	1	C3
	68	1	C6	1	C2	1	C10	1	C3
	100	1	C6	1	C2	1	C9	1	C1

- (1) No. represents the number of identical capacitor types to be connected in parallel.
- (2) C Code indicates the Capacitor Reference number in [Table 1](#) and [Table 2](#) for identifying the specific component from the manufacturer.

Table 7. Input Capacitors for Fixed Output Voltage Application—Surface Mount⁽¹⁾⁽²⁾⁽³⁾

OUTPUT VOLTAGE (V)	INDUCTANCE (μH)	SURFACE MOUNT					
		AVX TPS SERIES		SPRAGUE 594D SERIES		KEMET T495 SERIES	
		NO.	C CODE	NO.	C CODE	NO.	C CODE
3.3	10	3	C7	2	C10	3	C9
	15	See ⁽⁴⁾	See ⁽⁴⁾	3	C13	4	C12
	22	See ⁽⁴⁾	See ⁽⁴⁾	2	C13	3	C12
	33	See ⁽⁴⁾	See ⁽⁴⁾	2	C13	3	C12
5	10	3	C4	2	C6	3	C9
	15	4	C9	3	C12	4	C10
	22	See ⁽⁴⁾	See ⁽⁴⁾	3	C13	4	C12
	33	See ⁽⁴⁾	See ⁽⁴⁾	2	C13	3	C12
	47	See ⁽⁴⁾	See ⁽⁴⁾	1	C13	2	C12
12	10	4	C9	2	C10	4	C10
	15	4	C8	2	C10	4	C10
	22	4	C9	3	C12	4	C10
	33	See ⁽⁴⁾	See ⁽⁴⁾	3	C13	4	C12
	47	See ⁽⁴⁾	See ⁽⁴⁾	2	C13	3	C12
	68	See ⁽⁴⁾	See ⁽⁴⁾	2	C13	2	C12
	100	See ⁽⁴⁾	See ⁽⁴⁾	1	C13	2	C12

- (1) No. represents the number of identical capacitor types to be connected in parallel.
- (2) C Code indicates the Capacitor Reference number in [Table 1](#) and [Table 2](#) for identifying the specific component from the manufacturer.
- (3) Assumes worst case maximum input voltage and load current for a given inductance value
- (4) Check voltage rating of capacitors to be greater than application input voltage.

Table 8. Input Capacitors for Fixed Output Voltage Application—Through Hole⁽¹⁾⁽²⁾⁽³⁾

OUTPUT VOLTAGE (V)	INDUCTANCE (μH)	THROUGH HOLE							
		SANYO OS-CON SA SERIES		SANYO MV-GX SERIES		NICHICON PL SERIES		PANASONIC HFQ SERIES	
		NO.	C CODE	NO.	C CODE	NO.	C CODE	NO.	C CODE
3.3	10	2	C9	2	C8	1	C18	1	C8
	15	See ⁽⁴⁾	See ⁽⁴⁾	2	C13	1	C25	1	C16
	22	See ⁽⁴⁾	See ⁽⁴⁾	1	C14	1	C24	1	C16
	33	See ⁽⁴⁾	See ⁽⁴⁾	1	C14	1	C24	1	C16
5	10	2	C7	2	C8	1	C25	1	C8
	15	See ⁽⁴⁾	See ⁽⁴⁾	2	C8	1	C25	1	C8
	22	See ⁽⁴⁾	See ⁽⁴⁾	2	C13	1	C25	1	C16
	33	See ⁽⁴⁾	See ⁽⁴⁾	1	C14	1	C23	1	C13
	47	See ⁽⁴⁾	See ⁽⁴⁾	1	C12	1	C19	1	C11
12	10	2	C10	2	C8	1	C18	1	C8
	15	2	C10	2	C8	1	C18	1	C8
	22	See ⁽⁴⁾	See ⁽⁴⁾	2	C8	1	C18	1	C8
	33	See ⁽⁴⁾	See ⁽⁴⁾	2	C12	1	C24	1	C14
	47	See ⁽⁴⁾	See ⁽⁴⁾	1	C14	1	C23	1	C13
	68	See ⁽⁴⁾	See ⁽⁴⁾	1	C13	1	C21	1	C15
	100	See ⁽⁴⁾	See ⁽⁴⁾	1	C11	1	C22	1	C11

- (1) No. represents the number of identical capacitor types to be connected in parallel.
- (2) C Code indicates the Capacitor Reference number in Table 1 and Table 2 for identifying the specific component from the manufacturer.
- (3) Assumes worst case maximum input voltage and load current for a given inductance value
- (4) Check voltage rating of capacitors to be greater than application input voltage.

8.2.3 Adjustable Output Design Example

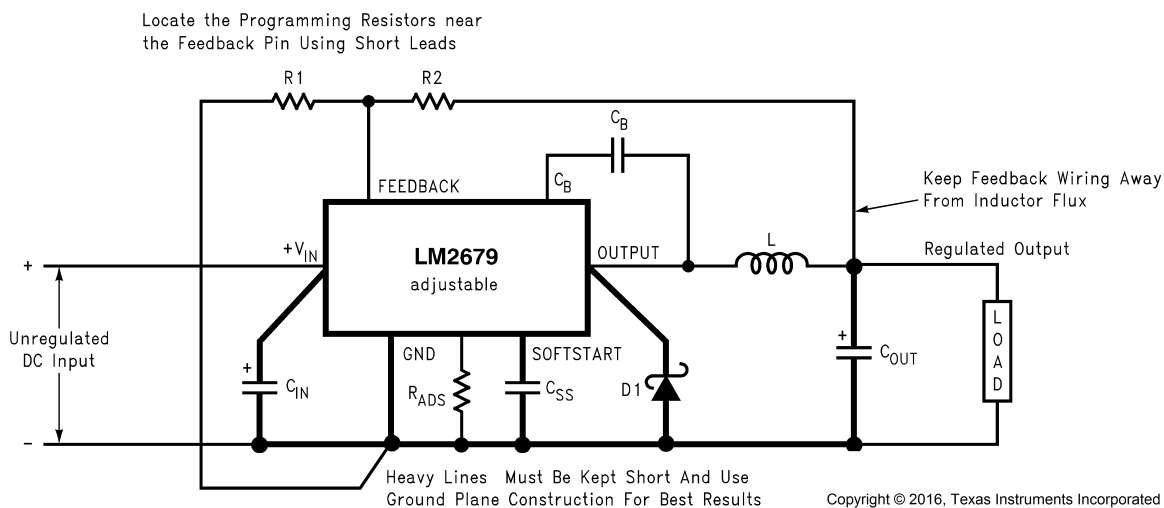

Figure 19. Basic Circuit for Adjustable Output Voltage Applications

8.2.3.1 Detailed Design Procedure

In this example it is desired to convert the voltage from a two battery automotive power supply (voltage range of 20 V to 28 V, typical in large truck applications) to the 14.8-VDC alternator supply typically used to power electronic equipment from single battery 12-V vehicle systems. The load current required is 3.5 A maximum. It is also desired to implement the power supply with all surface mount components. Soft start is not required.

Step 1: Operating conditions are:

- $V_{OUT} = 14.8 \text{ V}$
- $V_{IN \text{ max}} = 28 \text{ V}$
- $I_{LOAD \text{ max}} = 3.5 \text{ A}$

Step 2: Select an LM2679S-ADJ. To set the output voltage to 14.9 V, two resistors need to be chosen (R1 and R2 in [Figure 19](#)). For the adjustable device, the output voltage is set by [Equation 3](#).

$$V_{OUT} = V_{FB} \left(1 + \frac{R_2}{R_1} \right)$$

where

- V_{FB} is the feedback voltage of typically 1.21 V (3)

A recommended value to use for R1 is 1 k. In this example, R2 is determined with [Equation 4](#).

$$R_2 = R_1 \left(\frac{V_{OUT}}{V_{FB}} - 1 \right) = 1 \text{ k}\Omega \left(\frac{14.8\text{V}}{1.21\text{V}} - 1 \right) \quad (4)$$

$$R_2 = 11.23 \text{ k}\Omega$$

The closest standard 1% tolerance value to use is 11.3 k Ω

This sets the nominal output voltage to 14.88 V which is within 0.5% of the target value.

Step 3: To use the nomograph for the adjustable device, [Figure 17](#), requires a calculation of the inductor Volt • microsecond constant ($E \cdot T$ expressed in $\text{V} \cdot \mu\text{s}$) from [Equation 5](#).

$$E \cdot T = (V_{IN(\text{MAX})} - V_{OUT} - V_{SAT}) \cdot \frac{V_{OUT} + V_D}{V_{IN(\text{MAX})} - V_{SAT} + V_D} \cdot \frac{1000}{260} (\text{V} \cdot \mu\text{s})$$

where

- V_{SAT} is the voltage drop across the internal power switch which is $R_{ds(\text{ON})}$ times I_{LOAD} (5)

In this example, this is typically $0.12 \Omega \times 3.5 \text{ A}$ or 0.42 V and V_D is the voltage drop across the forward biased Schottky diode, typically 0.5 V. The switching frequency of 260 kHz is the nominal value to use to estimate the ON time of the switch during which energy is stored in the inductor.

For this example $E \cdot T$ is found with [Equation 6](#) and [Equation 7](#).

$$E \cdot T = (28 - 14.8 - 0.42) \cdot \frac{14.8 + 0.5}{28 - 0.42 + 0.5} \cdot \frac{1000}{260} (\text{V} \cdot \mu\text{s}) \quad (6)$$

$$E \cdot T = (12.78\text{V}) \cdot \frac{15.3\text{V}}{28.08\text{V}} \cdot 3.85 (\text{V} \cdot \mu\text{s}) = 26.8 (\text{V} \cdot \mu\text{s}) \quad (7)$$

Using [Figure 17](#), the intersection of 27 $\text{V} \cdot \mu\text{s}$ horizontally and the 3.5 A vertical line ($I_{LOAD \text{ max}}$) indicates that L48, a 47- μH inductor, or L49, a 33- μH inductor could be used. Either inductor is suitable, but for this example selecting the larger inductance results in lower ripple current.

From [Table 3](#), L48 in a surface mount component is available from Pulse Engineering with part number P0848.

Step 4: Use [Table 9](#) and [Table 10](#) to determine an output capacitor. With a 14.8-V output the 12.5 to 15 V row is used and with a 47- μH inductor there are three surface mount output capacitor solutions. [Table 1](#) and [Table 2](#) provide the actual capacitor characteristics based on the C Code number. Any of the following choices can be used:

- 1 \times 33- μF , 20-V AVX TPS (code C6)
- 1 \times 47- μF , 20-V Sprague 594 (code C8)
- 1 \times 47- μF , 20-V Kemet T495 (code C8)

NOTE

When using the adjustable device in low voltage applications (less than 3-V output), if the nomograph, [Figure 17](#), selects an inductance of 22 μH or less, [Table 9](#) and [Table 10](#) do not provide an output capacitor solution. With these conditions the number of output capacitors required for stable operation becomes impractical. It is recommended to use either a 33- μH or 47- μH inductor and the output capacitors from [Table 9](#) and [Table 10](#).

Step 5: An input capacitor for this example requires at least a 35-V WV rating with an RMS current rating of 1.75 A ($1/2 I_{OUT\ max}$). From [Table 1](#) and [Table 2](#), it can be seen that C12, a 33- μ F, 35-V capacitor from Sprague, has the highest voltage and current rating of the surface mount components and that two of these capacitor in parallel is adequate.

Step 6: From [Table 4](#), a 5-A or more Schottky diode must be selected. For surface mount diodes with a margin of safety on the voltage rating one of two diodes can be used:

- MBRD1545CT
- 6TQ045S

Step 7: A 0.01- μ F capacitor is used for C_{BOOST} .

The soft-start pin is left open circuited.

Step 8: Determine a value for R_{ADJ} with [Equation 8](#) to provide a peak switch current limit of at least 3.5 A plus 50% or 5.25 A.

$$R_{ADJ} = \frac{37,125}{5.2A} = 7.14\ k\Omega \quad (8)$$

Use a value of 7.15 $k\Omega$.

8.2.3.1.1 Capacitor Selection

Table 9. Output Capacitors for Adjustable Output Voltage Applications—Surface Mount⁽¹⁾⁽²⁾

OUTPUT VOLTAGE (V)	INDUCTANCE (μ H)	SURFACE MOUNT					
		AVX TPS SERIES		SPRAGUE 594D SERIES		KEMET T495 SERIES	
		NO.	C CODE	NO.	C CODE	NO.	C CODE
1.21 to 2.5	33 ⁽³⁾	7	C1	6	C2	7	C3
	47 ⁽³⁾	5	C1	4	C2	5	C3
2.5 to 3.75	33 ⁽³⁾	4	C1	3	C2	4	C3
	47 ⁽³⁾	3	C1	2	C2	3	C3
3.75 to 5	22	4	C1	3	C2	4	C3
	33	3	C1	2	C2	3	C3
	47	2	C1	2	C2	2	C3
5 to 6.25	22	3	C2	3	C3	3	C4
	33	2	C2	2	C3	2	C4
	47	2	C2	2	C3	2	C4
	68	1	C2	1	C3	1	C4
6.25 to 7.5	22	3	C2	1	C4	3	C4
	33	2	C2	1	C3	2	C4
	47	1	C3	1	C4	1	C6
	68	1	C2	1	C3	1	C4
7.5 to 10	33	2	C5	1	C6	2	C8
	47	1	C5	1	C6	2	C8
	68	1	C5	1	C6	1	C8
	100	1	C4	1	C5	1	C8
10 to 12.5	33	1	C5	1	C6	2	C8
	47	1	C5	1	C6	2	C8
	68	1	C5	1	C6	1	C8
	100	1	C5	1	C6	1	C8

(1) No. represents the number of identical capacitor types to be connected in parallel.

(2) C Code indicates the Capacitor Reference number in [Table 1](#) and [Table 2](#) for identifying the specific component from the manufacturer.

(3) Set to a higher value for a practical design solution.

Table 9. Output Capacitors for Adjustable Output Voltage Applications—Surface Mount⁽¹⁾⁽²⁾ (continued)

OUTPUT VOLTAGE (V)	INDUCTANCE (μH)	SURFACE MOUNT					
		AVX TPS SERIES		SPRAGUE 594D SERIES		KEMET T495 SERIES	
		NO.	C CODE	NO.	C CODE	NO.	C CODE
12.5 to 15	33	1	C6	1	C8	1	C8
	47	1	C6	1	C8	1	C8
	68	1	C6	1	C8	1	C8
	100	1	C6	1	C8	1	C8
15 to 20	33	1	C8	1	C10	2	C10
	47	1	C8	1	C9	2	C10
	68	1	C8	1	C9	2	C10
	100	1	C8	1	C9	1	C10
20 to 30	33	2	C9	2	C11	2	C11
	47	1	C10	1	C12	1	C11
	68	1	C9	1	C12	1	C11
	100	1	C9	1	C12	1	C11
30 to 37	10	No values available		4	C13	8	C12
	15			3	C13	5	C12
	22			2	C13	4	C12
	33			1	C13	3	C12
	47			1	C13	2	C12
	68			1	C13	2	C12

Table 10. Output Capacitors for Adjustable Output Voltage Applications—Through Hole⁽¹⁾⁽²⁾

OUTPUT VOLTAGE (V)	INDUCTANCE (μH)	THROUGH HOLE							
		SANYO OS-CON SA SERIES		SANYO MV-GX SERIES		NICHICON PL SERIES		PANASONIC HFQ SERIES	
		NO.	C CODE	NO.	C CODE	NO.	C CODE	NO.	C CODE
1.21 to 2.5	33 ⁽³⁾	2	C3	5	C1	5	C3	3	C
	47 ⁽³⁾	2	C2	4	C1	3	C3	2	C5
2.5 to 3.75	33 ⁽³⁾	1	C3	3	C1	3	C1	2	C5
	47 ⁽³⁾	1	C2	2	C1	2	C3	1	C5
3.75 to 5	22	1	C3	3	C1	3	C1	2	C5
	33	1	C2	2	C1	2	C1	1	C5
	47	1	C2	2	C1	1	C3	1	C5
5 to 6.25	22	1	C5	2	C6	2	C3	2	C5
	33	1	C4	1	C6	2	C1	1	C5
	47	1	C4	1	C6	1	C3	1	C5
	68	1	C4	1	C6	1	C1	1	C5
6.25 to 7.5	22	1	C5	1	C6	2	C1	1	C5
	33	1	C4	1	C6	1	C3	1	C5
	47	1	C4	1	C6	1	C1	1	C5
	68	1	C4	1	C2	1	C1	1	C5
7.5 to 10	33	1	C7	1	C6	1	C14	1	C5
	47	1	C7	1	C6	1	C14	1	C5
	68	1	C7	1	C2	1	C14	1	C2
	100	1	C7	1	C2	1	C14	1	C2

(1) No. represents the number of identical capacitor types to be connected in parallel.
(2) C Code indicates the Capacitor Reference number in Table 1 and Table 2 for identifying the specific component from the manufacturer.
(3) Set to a higher value for a practical design solution.

Table 10. Output Capacitors for Adjustable Output Voltage Applications—Through Hole⁽¹⁾⁽²⁾ (continued)

OUTPUT VOLTAGE (V)	INDUCTANCE (μH)	THROUGH HOLE							
		SANYO OS-CON SA SERIES		SANYO MV-GX SERIES		NICHICON PL SERIES		PANASONIC HFQ SERIES	
		NO.	C CODE	NO.	C CODE	NO.	C CODE	NO.	C CODE
10 to 12.5	33	1	C7	1	C6	1	C14	1	C5
	47	1	C7	1	C2	1	C14	1	C5
	68	1	C7	1	C2	1	C9	1	C2
	100	1	C7	1	C2	1	C9	1	C2
12.5 to 15	33	1	C9	1	C10	1	C15	1	C2
	47	1	C9	1	C10	1	C15	1	C2
	68	1	C9	1	C10	1	C15	1	C2
	100	1	C9	1	C10	1	C15	1	C2
15 to 20	33	1	C10	1	C7	1	C15	1	C2
	47	1	C10	1	C7	1	C15	1	C2
	68	1	C10	1	C7	1	C15	1	C2
	100	1	C10	1	C7	1	C15	1	C2
20 to 30	33	No values available		1	C7	1	C16	1	C2
	47			1	C7	1	C16	1	C2
	68			1	C7	1	C16	1	C2
	100			1	C7	1	C16	1	C2
30 to 37	10	No values available		1	C12	1	C20	1	C10
	15			1	C11	1	C20	1	C11
	22			1	C11	1	C20	1	C10
	33			1	C11	1	C20	1	C10
	47			1	C11	1	C20	1	C10
	68			1	C11	1	C20	1	C10

9 Power Supply Recommendations

The LM2679 is designed to operate from an input voltage supply up to 40 V. This input supply must be well regulated and able to withstand maximum input current and maintain a stable voltage.

10 Layout

10.1 Layout Guidelines

Board layout is critical for the proper operation of switching power supplies. First, the ground plane area must be sufficient for thermal dissipation purposes. Second, appropriate guidelines must be followed to reduce the effects of switching noise. Switch mode converters are very fast switching devices. In such cases, the rapid increase of input current combined with the parasitic trace inductance generates unwanted $L di/dt$ noise spikes. The magnitude of this noise tends to increase as the output current increases. This noise may turn into electromagnetic interference (EMI) and can also cause problems in device performance. Therefore, take care in layout to minimize the effect of this switching noise. The most important layout rule is to keep the AC current loops as small as possible. [Figure 20](#) shows the current flow in a buck converter. The top schematic shows a dotted line which represents the current flow during the top switch on-state. The middle schematic shows the current flow during the top switch off-state. The bottom schematic shows the currents referred to as ac currents. These ac currents are the most critical because they are changing in a very short time period. The dotted lines of the bottom schematic are the traces to keep as short and wide as possible. This also yields a small loop area reducing the loop inductance. To avoid functional problems due to layout, review the PCB layout example. Best results are achieved if the placement of the LM2679 device, the bypass capacitor, the Schottky diode, RFBB, RFBT, and the inductor are placed as shown in the example. Note that, in the layout shown, $R1 = RFBB$ and $R2 = RFBT$. TI also recommends using 2-oz. copper boards or heavier to help thermal dissipation and to reduce the parasitic inductances of board traces. See [AN-1229 SIMPLE SWITCHER® PCB Layout Guidelines](#) for more information.

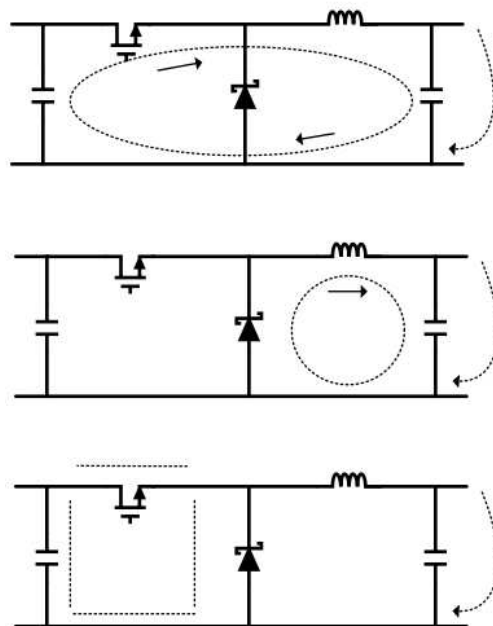

Figure 20. Buck Converter Current Flow

10.2 Layout Example

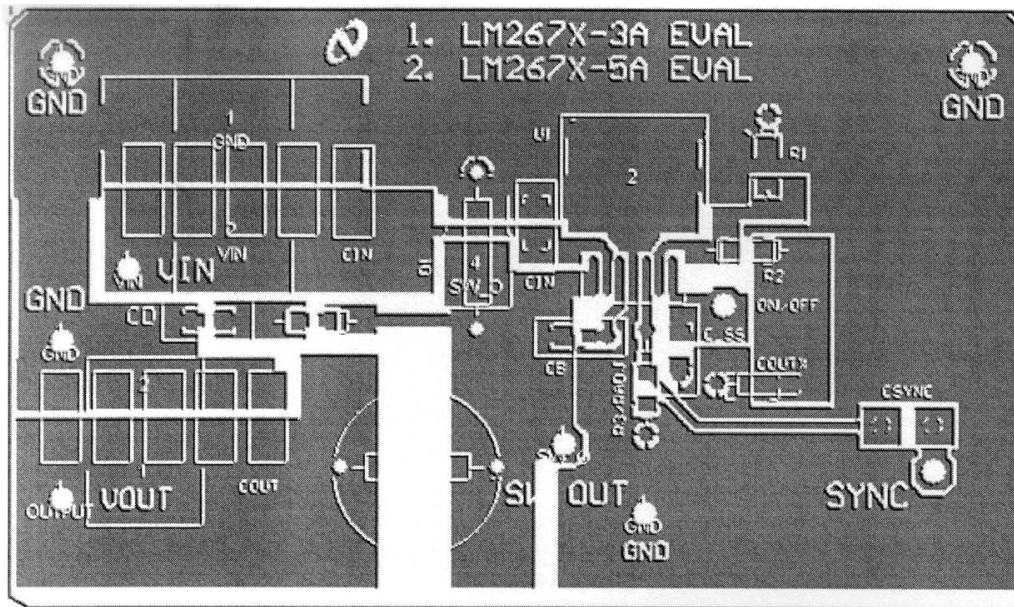

Figure 21. Top Layer Foil Pattern of Printed-Circuit Board

11 Device and Documentation Support

11.1 Related Documentation

For related documentation see the following:

- [AN-1187 Leadless Leadfram Package \(LLP\)](#) (SNOA401)
- [AN-1229 SIMPLE SWITCHER® PCB Layout Guidelines](#) (SNVA054)

11.2 Receiving Notification of Documentation Updates

To receive notification of documentation updates, navigate to the device product folder on ti.com. In the upper right corner, click on *Alert me* to register and receive a weekly digest of any product information that has changed. For change details, review the revision history included in any revised document.

11.3 Community Resources

The following links connect to TI community resources. Linked contents are provided "AS IS" by the respective contributors. They do not constitute TI specifications and do not necessarily reflect TI's views; see TI's [Terms of Use](#).

TI E2E™ Online Community *TI's Engineer-to-Engineer (E2E) Community*. Created to foster collaboration among engineers. At e2e.ti.com, you can ask questions, share knowledge, explore ideas and help solve problems with fellow engineers.

Design Support *TI's Design Support* Quickly find helpful E2E forums along with design support tools and contact information for technical support.

11.4 Trademarks

E2E is a trademark of Texas Instruments.
SIMPLE SWITCHER is a registered trademark of Texas Instruments.
All other trademarks are the property of their respective owners.

11.5 Electrostatic Discharge Caution



These devices have limited built-in ESD protection. The leads should be shorted together or the device placed in conductive foam during storage or handling to prevent electrostatic damage to the MOS gates.

11.6 Glossary

[SLYZ022](#) — *TI Glossary*.

This glossary lists and explains terms, acronyms, and definitions.

12 Mechanical, Packaging, and Orderable Information

The following pages include mechanical, packaging, and orderable information. This information is the most current data available for the designated devices. This data is subject to change without notice and revision of this document. For browser-based versions of this data sheet, refer to the left-hand navigation.

12.1 VSON Package Devices

The LM2679 is offered in the 14-lead VSON surface mount package to allow for a significantly decreased footprint with equivalent power dissipation compared to the DDPK.

The Die Attach Pad (DAP) can and must be connected to PCB Ground plane or island. For CAD and assembly guidelines, refer to [AN-1187 Leadless Leadfram Package \(LLP\)](#).

PACKAGING INFORMATION

Orderable Device	Status (1)	Package Type	Package Drawing	Pins	Package Qty	Eco Plan (2)	Lead/Ball Finish (6)	MSL Peak Temp (3)	Op Temp (°C)	Device Marking (4/5)	Samples
LM2679S-12/NOPB	ACTIVE	DDPAK/ TO-263	KTW	7	45	Pb-Free (RoHS Exempt)	CU SN	Level-3-245C-168 HR	-40 to 125	LM2679 S-12	Samples
LM2679S-3.3	NRND	DDPAK/ TO-263	KTW	7	45	TBD	Call TI	Call TI	-40 to 125	LM2679 S-3.3	
LM2679S-3.3/NOPB	ACTIVE	DDPAK/ TO-263	KTW	7	45	Pb-Free (RoHS Exempt)	CU SN	Level-3-245C-168 HR	-40 to 125	LM2679 S-3.3	Samples
LM2679S-5.0	NRND	DDPAK/ TO-263	KTW	7	45	TBD	Call TI	Call TI	-40 to 125	LM2679 S-5.0	
LM2679S-5.0/NOPB	ACTIVE	DDPAK/ TO-263	KTW	7	45	Pb-Free (RoHS Exempt)	CU SN	Level-3-245C-168 HR	-40 to 125	LM2679 S-5.0	Samples
LM2679S-ADJ	NRND	DDPAK/ TO-263	KTW	7	45	TBD	Call TI	Call TI	-40 to 125	LM2679 S-ADJ	
LM2679S-ADJ/NOPB	ACTIVE	DDPAK/ TO-263	KTW	7	45	Pb-Free (RoHS Exempt)	CU SN	Level-3-245C-168 HR	-40 to 125	LM2679 S-ADJ	Samples
LM2679SD-3.3/NOPB	ACTIVE	VSON	NHM	14	250	Green (RoHS & no Sb/Br)	CU SN	Level-1-260C-UNLIM	-40 to 125	S0003HB	Samples
LM2679SD-5.0/NOPB	ACTIVE	VSON	NHM	14	250	Green (RoHS & no Sb/Br)	CU SN	Level-1-260C-UNLIM	-40 to 125	S0003JB	Samples
LM2679SD-ADJ/NOPB	ACTIVE	VSON	NHM	14	250	Green (RoHS & no Sb/Br)	CU SN	Level-1-260C-UNLIM	-40 to 125	S0003KB	Samples
LM2679SDX-3.3/NOPB	ACTIVE	VSON	NHM	14	2500	Green (RoHS & no Sb/Br)	CU SN	Level-1-260C-UNLIM	-40 to 125	S0003HB	Samples
LM2679SDX-ADJ/NOPB	ACTIVE	VSON	NHM	14	2500	Green (RoHS & no Sb/Br)	CU SN	Level-1-260C-UNLIM	-40 to 125	S0003KB	Samples
LM2679SX-12/NOPB	ACTIVE	DDPAK/ TO-263	KTW	7	500	Pb-Free (RoHS Exempt)	CU SN	Level-3-245C-168 HR	-40 to 125	LM2679 S-12	Samples
LM2679SX-3.3/NOPB	ACTIVE	DDPAK/ TO-263	KTW	7	500	Pb-Free (RoHS Exempt)	CU SN	Level-3-245C-168 HR	-40 to 125	LM2679 S-3.3	Samples
LM2679SX-5.0	NRND	DDPAK/ TO-263	KTW	7	500	TBD	Call TI	Call TI	-40 to 125	LM2679 S-5.0	
LM2679SX-5.0/NOPB	ACTIVE	DDPAK/ TO-263	KTW	7	500	Pb-Free (RoHS Exempt)	CU SN	Level-3-245C-168 HR	-40 to 125	LM2679 S-5.0	Samples
LM2679SX-ADJ	NRND	DDPAK/ TO-263	KTW	7	500	TBD	Call TI	Call TI	-40 to 125	LM2679 S-ADJ	

Orderable Device	Status (1)	Package Type	Package Drawing	Pins	Package Qty	Eco Plan (2)	Lead/Ball Finish (6)	MSL Peak Temp (3)	Op Temp (°C)	Device Marking (4/5)	Samples
LM2679SX-ADJ/NOPB	ACTIVE	DDPAK/ TO-263	KTW	7	500	Pb-Free (RoHS Exempt)	CU SN	Level-3-245C-168 HR	-40 to 125	LM2679 S-ADJ	Samples
LM2679T-12/NOPB	ACTIVE	TO-220	NDZ	7	45	Green (RoHS & no Sb/Br)	CU SN	Level-1-NA-UNLIM	-40 to 125	LM2679 T-12	Samples
LM2679T-3.3/NOPB	ACTIVE	TO-220	NDZ	7	45	Green (RoHS & no Sb/Br)	CU SN	Level-1-NA-UNLIM	-40 to 125	LM2679 T-3.3	Samples
LM2679T-5.0/NOPB	ACTIVE	TO-220	NDZ	7	45	Green (RoHS & no Sb/Br)	CU SN	Level-1-NA-UNLIM	-40 to 125	LM2679 T-5.0	Samples
LM2679T-ADJ/NOPB	ACTIVE	TO-220	NDZ	7	45	Green (RoHS & no Sb/Br)	CU SN	Level-1-NA-UNLIM	-40 to 125	LM2679 T-ADJ	Samples

(1) The marketing status values are defined as follows:

ACTIVE: Product device recommended for new designs.

LIFEBUY: TI has announced that the device will be discontinued, and a lifetime-buy period is in effect.

NRND: Not recommended for new designs. Device is in production to support existing customers, but TI does not recommend using this part in a new design.

PREVIEW: Device has been announced but is not in production. Samples may or may not be available.

OBSOLETE: TI has discontinued the production of the device.

(2) **RoHS:** TI defines "RoHS" to mean semiconductor products that are compliant with the current EU RoHS requirements for all 10 RoHS substances, including the requirement that RoHS substance do not exceed 0.1% by weight in homogeneous materials. Where designed to be soldered at high temperatures, "RoHS" products are suitable for use in specified lead-free processes. TI may reference these types of products as "Pb-Free".

RoHS Exempt: TI defines "RoHS Exempt" to mean products that contain lead but are compliant with EU RoHS pursuant to a specific EU RoHS exemption.

Green: TI defines "Green" to mean the content of Chlorine (Cl) and Bromine (Br) based flame retardants meet JS709B low halogen requirements of <=1000ppm threshold. Antimony trioxide based flame retardants must also meet the <=1000ppm threshold requirement.

(3) MSL, Peak Temp. - The Moisture Sensitivity Level rating according to the JEDEC industry standard classifications, and peak solder temperature.

(4) There may be additional marking, which relates to the logo, the lot trace code information, or the environmental category on the device.

(5) Multiple Device Markings will be inside parentheses. Only one Device Marking contained in parentheses and separated by a "-" will appear on a device. If a line is indented then it is a continuation of the previous line and the two combined represent the entire Device Marking for that device.

(6) Lead/Ball Finish - Orderable Devices may have multiple material finish options. Finish options are separated by a vertical ruled line. Lead/Ball Finish values may wrap to two lines if the finish value exceeds the maximum column width.

Important Information and Disclaimer: The information provided on this page represents TI's knowledge and belief as of the date that it is provided. TI bases its knowledge and belief on information provided by third parties, and makes no representation or warranty as to the accuracy of such information. Efforts are underway to better integrate information from third parties. TI has taken and

continues to take reasonable steps to provide representative and accurate information but may not have conducted destructive testing or chemical analysis on incoming materials and chemicals. TI and TI suppliers consider certain information to be proprietary, and thus CAS numbers and other limited information may not be available for release.

In no event shall TI's liability arising out of such information exceed the total purchase price of the TI part(s) at issue in this document sold by TI to Customer on an annual basis.

TAPE AND REEL INFORMATION

QUADRANT ASSIGNMENTS FOR PIN 1 ORIENTATION IN TAPE

*All dimensions are nominal

Device	Package Type	Package Drawing	Pins	SPQ	Reel Diameter (mm)	Reel Width W1 (mm)	A0 (mm)	B0 (mm)	K0 (mm)	P1 (mm)	W (mm)	Pin1 Quadrant
LM2679SD-3.3/NOPB	VSON	NHM	14	250	178.0	16.4	5.3	6.3	1.5	12.0	16.0	Q1
LM2679SD-5.0/NOPB	VSON	NHM	14	250	178.0	16.4	5.3	6.3	1.5	12.0	16.0	Q1
LM2679SD-ADJ/NOPB	VSON	NHM	14	250	178.0	16.4	5.3	6.3	1.5	12.0	16.0	Q1
LM2679SDX-3.3/NOPB	VSON	NHM	14	2500	330.0	16.4	5.3	6.3	1.5	12.0	16.0	Q1
LM2679SDX-ADJ/NOPB	VSON	NHM	14	2500	330.0	16.4	5.3	6.3	1.5	12.0	16.0	Q1
LM2679SX-12/NOPB	DDPAK/ TO-263	KTW	7	500	330.0	24.4	10.75	14.85	5.0	16.0	24.0	Q2
LM2679SX-3.3/NOPB	DDPAK/ TO-263	KTW	7	500	330.0	24.4	10.75	14.85	5.0	16.0	24.0	Q2
LM2679SX-5.0	DDPAK/ TO-263	KTW	7	500	330.0	24.4	10.75	14.85	5.0	16.0	24.0	Q2
LM2679SX-5.0/NOPB	DDPAK/ TO-263	KTW	7	500	330.0	24.4	10.75	14.85	5.0	16.0	24.0	Q2
LM2679SX-ADJ	DDPAK/ TO-263	KTW	7	500	330.0	24.4	10.75	14.85	5.0	16.0	24.0	Q2
LM2679SX-ADJ/NOPB	DDPAK/ TO-263	KTW	7	500	330.0	24.4	10.75	14.85	5.0	16.0	24.0	Q2

TAPE AND REEL BOX DIMENSIONS



*All dimensions are nominal

Device	Package Type	Package Drawing	Pins	SPQ	Length (mm)	Width (mm)	Height (mm)
LM2679SD-3.3/NOPB	VSON	NHM	14	250	210.0	185.0	35.0
LM2679SD-5.0/NOPB	VSON	NHM	14	250	210.0	185.0	35.0
LM2679SD-ADJ/NOPB	VSON	NHM	14	250	210.0	185.0	35.0
LM2679SDX-3.3/NOPB	VSON	NHM	14	2500	367.0	367.0	35.0
LM2679SDX-ADJ/NOPB	VSON	NHM	14	2500	367.0	367.0	35.0
LM2679SX-12/NOPB	DDPAK/TO-263	KTW	7	500	367.0	367.0	45.0
LM2679SX-3.3/NOPB	DDPAK/TO-263	KTW	7	500	367.0	367.0	45.0
LM2679SX-5.0	DDPAK/TO-263	KTW	7	500	367.0	367.0	45.0
LM2679SX-5.0/NOPB	DDPAK/TO-263	KTW	7	500	367.0	367.0	45.0
LM2679SX-ADJ	DDPAK/TO-263	KTW	7	500	367.0	367.0	45.0
LM2679SX-ADJ/NOPB	DDPAK/TO-263	KTW	7	500	367.0	367.0	45.0

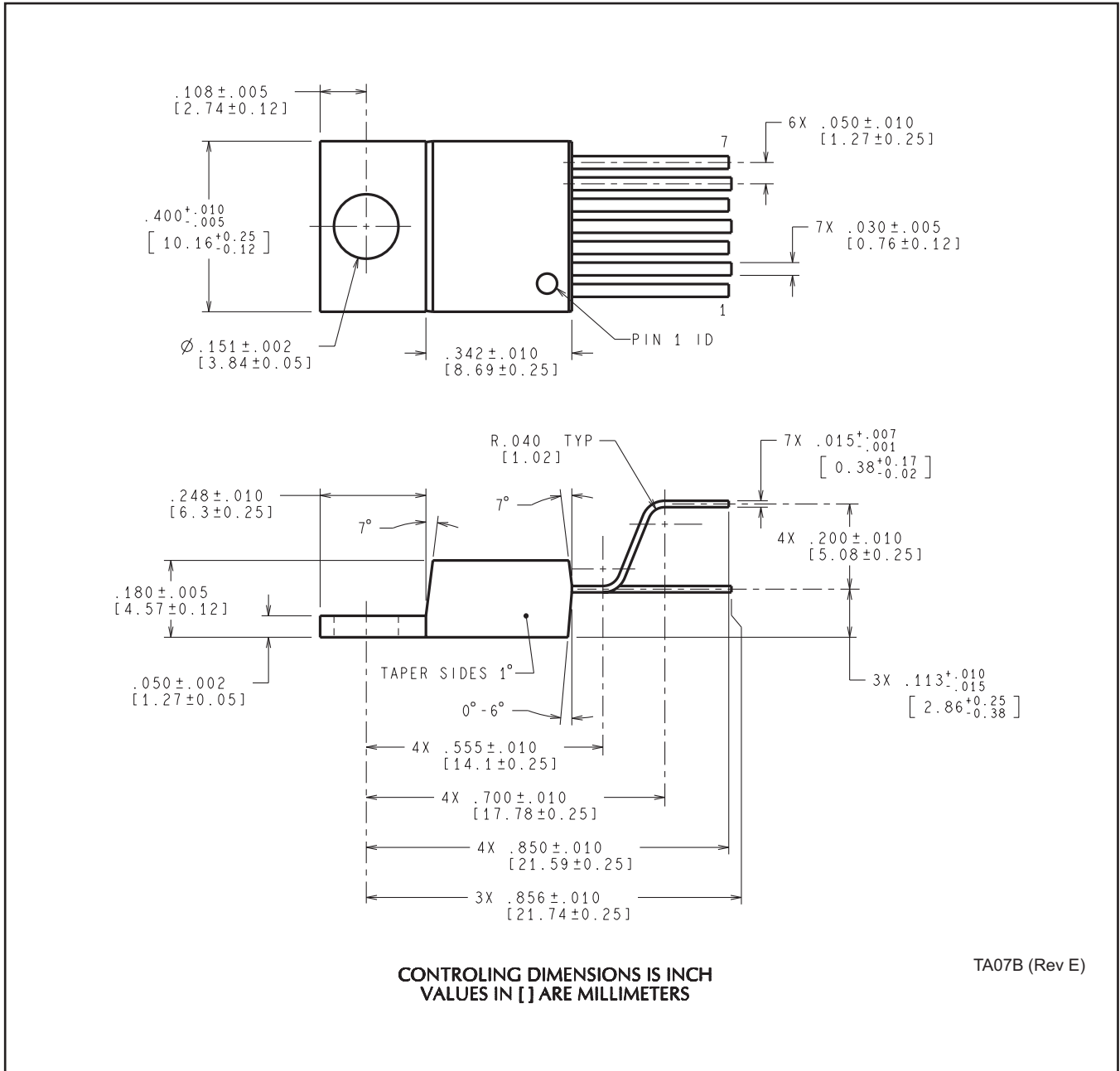
NDZ0007B

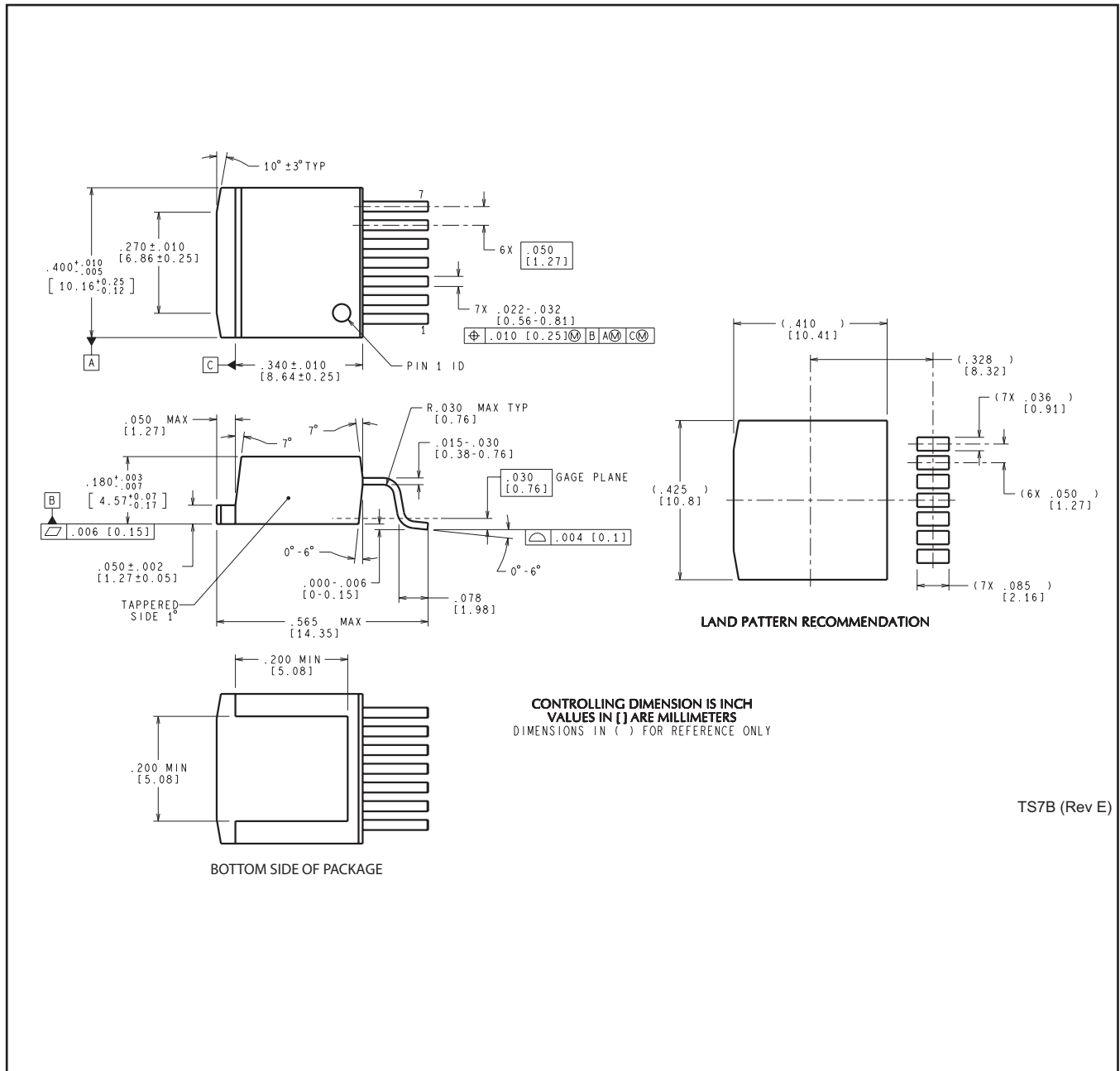

KTW0007B



TS7B (Rev E)

NHM0014A

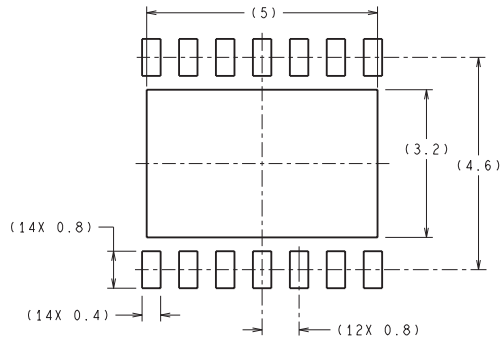

DIMENSIONS ARE IN MILLIMETERS
DIMENSIONS IN () FOR REFERENCE ONLY

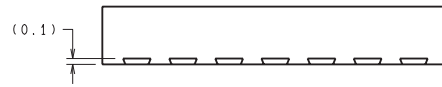

RECOMMENDED LAND PATTERN

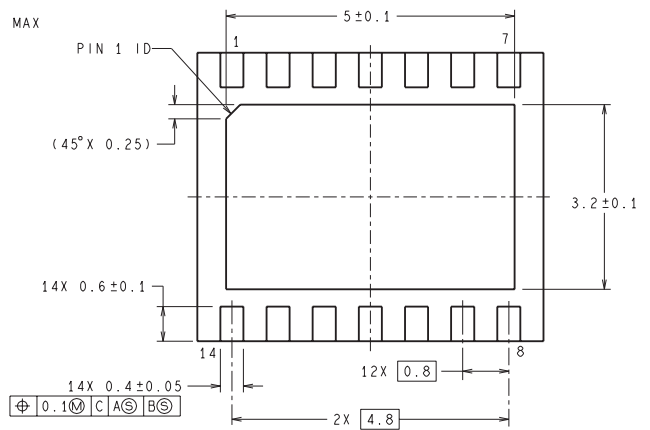
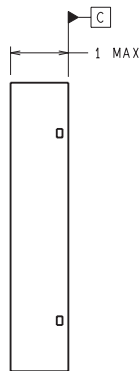
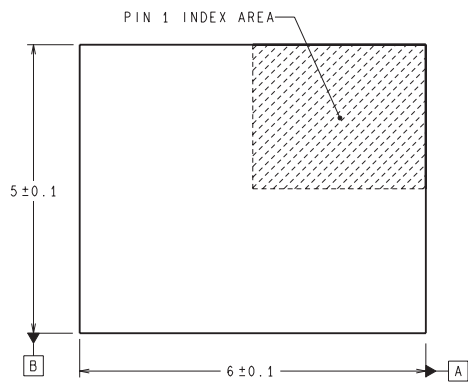

SRC14A (Rev A)

IMPORTANT NOTICE AND DISCLAIMER

TI PROVIDES TECHNICAL AND RELIABILITY DATA (INCLUDING DATASHEETS), DESIGN RESOURCES (INCLUDING REFERENCE DESIGNS), APPLICATION OR OTHER DESIGN ADVICE, WEB TOOLS, SAFETY INFORMATION, AND OTHER RESOURCES "AS IS" AND WITH ALL FAULTS, AND DISCLAIMS ALL WARRANTIES, EXPRESS AND IMPLIED, INCLUDING WITHOUT LIMITATION ANY IMPLIED WARRANTIES OF MERCHANTABILITY, FITNESS FOR A PARTICULAR PURPOSE OR NON-INFRINGEMENT OF THIRD PARTY INTELLECTUAL PROPERTY RIGHTS.

These resources are intended for skilled developers designing with TI products. You are solely responsible for (1) selecting the appropriate TI products for your application, (2) designing, validating and testing your application, and (3) ensuring your application meets applicable standards, and any other safety, security, or other requirements. These resources are subject to change without notice. TI grants you permission to use these resources only for development of an application that uses the TI products described in the resource. Other reproduction and display of these resources is prohibited. No license is granted to any other TI intellectual property right or to any third party intellectual property right. TI disclaims responsibility for, and you will fully indemnify TI and its representatives against, any claims, damages, costs, losses, and liabilities arising out of your use of these resources.

TI's products are provided subject to TI's Terms of Sale (www.ti.com/legal/termsofsale.html) or other applicable terms available either on ti.com or provided in conjunction with such TI products. TI's provision of these resources does not expand or otherwise alter TI's applicable warranties or warranty disclaimers for TI products.

Mailing Address: Texas Instruments, Post Office Box 655303, Dallas, Texas 75265
Copyright © 2018, Texas Instruments Incorporated

Looking for pricing, stock, or lifecycle information?

Click below to explore more details on WIN SOURCE:

 [View LM2679SX-5.0/NOPB on WIN SOURCE](#)

 [Texas Instruments](#) Information

Optimize Your Supply Chain with WIN SOURCE Solutions

-  Global Sourcing Solution
-  Obsolete Management
-  Cost Control Management
-  Shortage Management
-  Alternative Solution
-  Excess Inventory Management