



THE DATASHEET OF LM2682MM/NOPB



LM2682 Switched Capacitor Voltage Doubling Inverter

Check for Samples: [LM2682](#)

FEATURES

- Inverts Then Doubles Input Supply Voltage
- Small VSSOP Package and SOIC Package
- 90Ω Typical Output Impedance
- 94% Typical Power Efficiency at 10 mA

APPLICATIONS

- LCD Contrast Biasing
- GaAs Power Amplifier Biasing
- Interface Power Supplies
- Handheld Instrumentation
- Laptop Computers and PDAs

DESCRIPTION

The LM2682 is a CMOS charge-pump voltage inverter capable of converting positive voltage in the range of +2.0V to +5.5V to the corresponding doubled negative voltage of -4.0V to -11.0V respectively. The LM2682 uses three low cost capacitors to provide 10 mA of output current without the cost, size, and EMI related to inductor based circuits. With an operating current of only 150 μA and an operating efficiency greater than 90% with most loads, the LM2682 provides ideal performance for battery powered systems. The LM2682 offers a switching frequency of 6 kHz.

Typical Operating Circuit and Pin Configuration

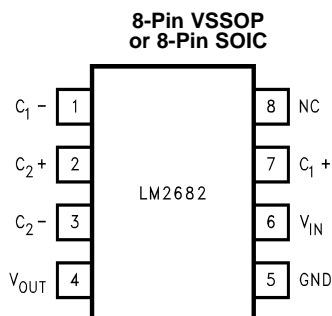
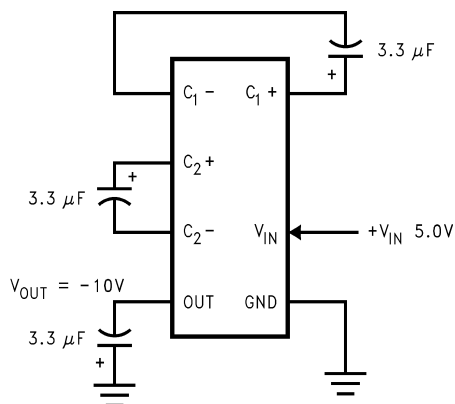

These devices have limited built-in ESD protection. The leads should be shorted together or the device placed in conductive foam during storage or handling to prevent electrostatic damage to the MOS gates.



Please be aware that an important notice concerning availability, standard warranty, and use in critical applications of Texas Instruments semiconductor products and disclaimers thereto appears at the end of this data sheet.

All trademarks are the property of their respective owners.

Absolute Maximum Ratings⁽¹⁾

Input Voltage (V_{IN})		+5.8V
V_{IN} dV/dT		1V/ μ sec
V_{OUT}		-11.6V
V_{OUT} Short-Circuit Duration		Continuous
Storage Temperature		-65°C to +150°C
Lead Temperature Soldering		+300°C
Power Dissipation ⁽²⁾	VSSOP	300 mW
	SOIC	470 mW
T_{JMAX}		+150°C

- (1) Absolute Maximum Ratings are those values beyond which damage to the device may occur. Operating Ratings indicate conditions for which the device is intended to be functional, but do not ensure specific performance limits. For ensured specifications and test conditions, see the Electrical Characteristics.
- (2) The maximum power dissipation must be de-rated at elevated temperatures (only needed for $T_A > 85^\circ\text{C}$) and is limited by T_{JMAX} (maximum junction temperature), θ_{J-A} (junction to ambient thermal resistance) and T_A (ambient temperature). θ_{J-A} is 140°C/W for the SOIC-8 package and 220°C/W for the VSSOP-8 package. The maximum power dissipation at any temperature is: $P_{DissMAX} = (T_{JMAX} - T_A)/\theta_{J-A}$ up to the value listed in the Absolute Maximum Ratings.

Operating Ratings

ESD Susceptibility ⁽¹⁾	Human Body Model	2 kV
	Machine Model	200V
Ambient Temp. Range		-40°C to +85°C
Junction Temp. Range		-40°C to +125°C

- (1) The human body model is a 100 pF capacitor discharged through a 1.5 k Ω resistor into each pin. The machine model is a 200pF capacitor discharged directly into each pin.

LM2682

Electrical Characteristics

$V_{IN} = 5\text{V}$ and $C_1 = C_2 = C_3 = 3.3\mu\text{F}$ unless otherwise specified. Limits with **bold typeface** apply over the full operating ambient temperature range, -40°C to +85°C, limits with standard typeface apply for $T_A = 25^\circ\text{C}$.

Symbol	Parameter	Conditions	Min	Typical ⁽¹⁾	Max	Units
V_{IN}	Supply Voltage Range	$R_L = 2\text{ k}\Omega$	2.0		5.5	V
I_{IN}	Supply Current	Open Circuit, No Load		150	300 400	μA
R_{OUT}	V_{OUT} Source Resistance	$I_L = 10\text{ mA}$		90	150 200	Ω
		$I_L = 5\text{ mA}, V_{IN} = 2\text{ V}$		110	250	Ω
f_{OSC}	Oscillator Frequency	See ⁽²⁾		12	30	kHz
f_{SW}	Switching Frequency	See ⁽²⁾		6	15	kHz
η_{POWER}	Power Efficiency	$R_L = 2\text{ k}\Omega$ ⁽³⁾	90	93		%
$\eta_{VOLTAGE}$	Voltage Conversion Efficiency			99.9		%

- (1) Typical numbers are at 25°C and represent the most likely norm.
- (2) The output switches operate at one half of the oscillator frequency, $f_{OSC} = 2f_{SW}$.
- (3) The minimum specification is specified by design and is not tested.

Table 1. PIN DESCRIPTIONS

Pin Number	Symbol	Description
1	C ₁ -	Capacitor C ₁ negative terminal
2	C ₂ +	Capacitor C ₂ positive terminal
3	C ₂ -	Capacitor C ₂ negative terminal
4	V _{OUT}	Negative output voltage ($-2V_{IN}$)
5	GND	Device ground
6	V _{IN}	Power supply voltage
7	C ₁ +	Capacitor C ₁ positive terminal
8	NC	No Connection

Typical Performance Characteristics

$V_{IN} = 5V$ and $T_A = 25^\circ C$ unless otherwise noted.

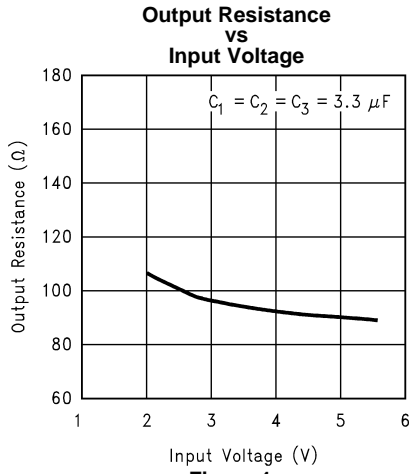

Figure 1.

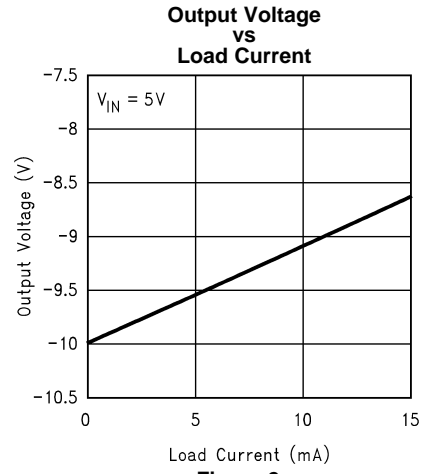

Figure 2.

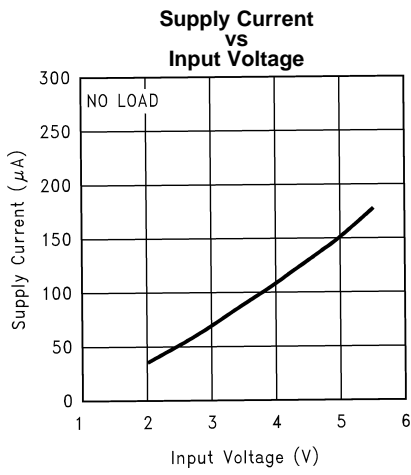

Figure 3.

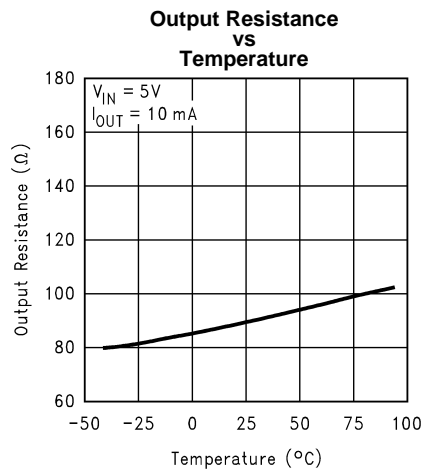

Figure 4.

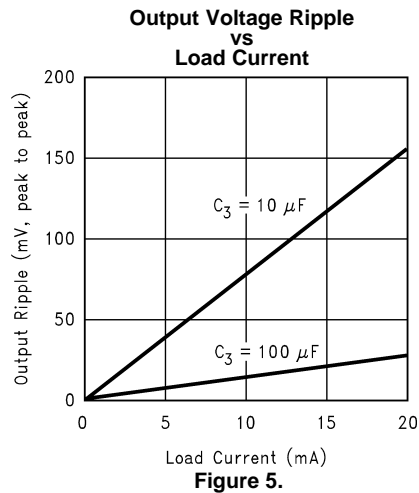

Figure 5.

BASIC APPLICATION CIRCUITS

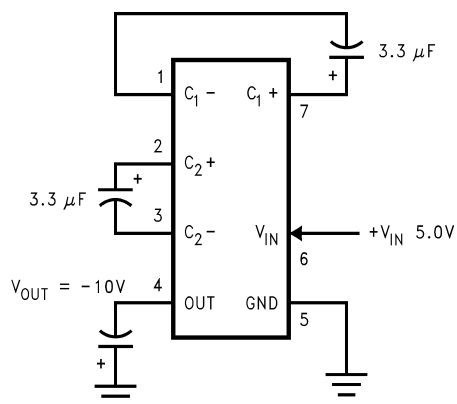

Figure 6. Doubling Voltage Inverter

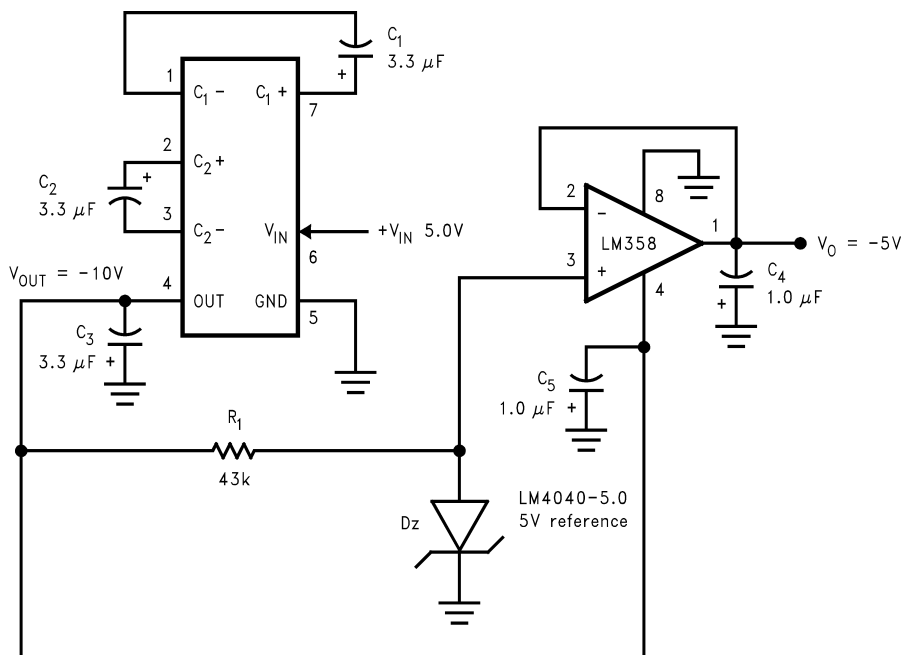

Figure 7. +5V to -5V Regulated Voltage Converter

APPLICATION INFORMATION

VOLTAGE DOUBLING INVERTER

The main application of the LM2682 is to generate a negative voltage that is twice the positive input voltage. This circuit requires only three external capacitors and is connected as shown in [Figure 6](#). It is important to keep in mind that the efficiency of the circuit is determined by the output resistance. A derivation of the output resistance is shown below:

$$R_{OUT} = 2(R_{SW1} + R_{SW2} + ESR_{C1} + R_{SW3} + R_{SW4} + ESR_{C2}) + 2(R_{SW1} + R_{SW2} + ESR_{C1} + R_{SW3} + R_{SW4} + ESR_{C2}) + 1/(f_{OSC} \times C1) + 1/(f_{OSC} \times C2) + ESR_{C3}$$

Using the assumption that all four switches have the same ON resistance our equation becomes:

$$R_{OUT} = 16R_{SW} + 4ESR_{C1} + 4ESR_{C2} + ESR_{C3} + 1/(f_{OSC} \times C1) + 1/(f_{OSC} \times C2)$$

Output resistance is typically 90Ω with an input voltage of +5V, an operating temperature of 25°C, and using low ESR 3.3 μF capacitors. This equation shows the importance of capacitor selection. Large value, low ESR capacitors will reduce the output resistance significantly but will also require a larger overall circuit. Smaller capacitors will take up less space but can lower efficiency greatly if the ESR is large. Also to be considered is that C1 must be rated at 6 VDC or greater while C2 and C3 must be rated at 12 VDC or greater.

The amount of output voltage ripple is determined by the output capacitor C3 and the output current as shown in this equation:

$$V_{RIPPLE\ P-P} = I_{OUT} \times (2 \times ESR_{C3} + 1/[2 \times (f_{OSC} \times C3)])$$

Once again a larger capacitor with smaller ESR will give better results.

+5V TO -5V REGULATED VOLTAGE CONVERTER

Another application in which the LM2682 can be used is for generating a -5V regulated supply from a +5V unregulated supply. This involves using an op-amp and a reference and is connected as shown in [Figure 7](#). The LM358 op-amp was chosen for its low cost and versatility and the LM4040-5.0 reference was chosen for its low bias current requirement. Of course other combinations may be used at the designer's discretion to fit accuracy, efficiency, and cost requirements. With this configuration the circuit is well regulated and is still capable of providing nearly 10 mA of output current. With a 9 mA load the circuit can typically maintain 5% regulation on the output voltage with the input varying anywhere from 4.5V to the maximum of 5.5V. With less load the results are even better. Voltage ripple concerns are reduced in this case since the ripple at the output of the LM2682 is reduced at the output by the PSRR of the op-amp used.

PARALLELING DEVICES

Any number of devices can be paralleled to reduce the output resistance. As shown in Figure 8, each device must have its own pumping capacitors, C1 and C2, but only one shared output capacitor is required. The effective output resistance is the output resistance of one device divided by the number of devices used in parallel. Paralleling devices also gives the capability of increasing the maximum output current. The maximum output current now becomes the maximum output current for one device multiplied by the number of devices used in parallel. For example, if you parallel two devices you can get 20 mA of output current and have half the output resistance of one device supplying 10 mA.

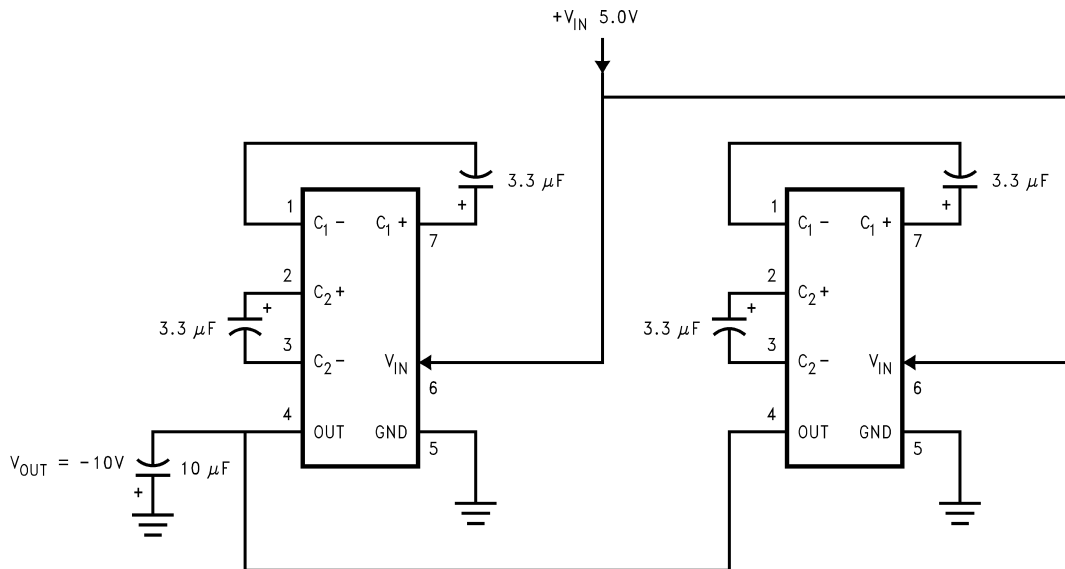

Figure 8. Paralleling Devices

REVISION HISTORY

Changes from Revision A (May 2013) to Revision B	Page
• Changed layout of National Data Sheet to TI format	7

PACKAGING INFORMATION

Orderable Device	Status (1)	Package Type	Package Drawing	Pins	Package Qty	Eco Plan (2)	Lead/Ball Finish (6)	MSL Peak Temp (3)	Op Temp (°C)	Device Marking (4/5)	Samples
LM2682MM/NOPB	ACTIVE	VSSOP	DGK	8	1000	Green (RoHS & no Sb/Br)	CU SN	Level-1-260C-UNLIM	-40 to 85	S11A	Samples
LM2682MMX/NOPB	ACTIVE	VSSOP	DGK	8	3500	Green (RoHS & no Sb/Br)	CU SN	Level-1-260C-UNLIM	-40 to 85	S11A	Samples

(1) The marketing status values are defined as follows:

ACTIVE: Product device recommended for new designs.

LIFEBUY: TI has announced that the device will be discontinued, and a lifetime-buy period is in effect.

NRND: Not recommended for new designs. Device is in production to support existing customers, but TI does not recommend using this part in a new design.

PREVIEW: Device has been announced but is not in production. Samples may or may not be available.

OBSELETE: TI has discontinued the production of the device.

(2) Eco Plan - The planned eco-friendly classification: Pb-Free (RoHS), Pb-Free (RoHS Exempt), or Green (RoHS & no Sb/Br) - please check <http://www.ti.com/productcontent> for the latest availability information and additional product content details.

TBD: The Pb-Free/Green conversion plan has not been defined.

Pb-Free (RoHS): TI's terms "Lead-Free" or "Pb-Free" mean semiconductor products that are compatible with the current RoHS requirements for all 6 substances, including the requirement that lead not exceed 0.1% by weight in homogeneous materials. Where designed to be soldered at high temperatures, TI Pb-Free products are suitable for use in specified lead-free processes.

Pb-Free (RoHS Exempt): This component has a RoHS exemption for either 1) lead-based flip-chip solder bumps used between the die and package, or 2) lead-based die adhesive used between the die and leadframe. The component is otherwise considered Pb-Free (RoHS compatible) as defined above.

Green (RoHS & no Sb/Br): TI defines "Green" to mean Pb-Free (RoHS compatible), and free of Bromine (Br) and Antimony (Sb) based flame retardants (Br or Sb do not exceed 0.1% by weight in homogeneous material)

(3) MSL, Peak Temp. - The Moisture Sensitivity Level rating according to the JEDEC industry standard classifications, and peak solder temperature.

(4) There may be additional marking, which relates to the logo, the lot trace code information, or the environmental category on the device.

(5) Multiple Device Markings will be inside parentheses. Only one Device Marking contained in parentheses and separated by a "~" will appear on a device. If a line is indented then it is a continuation of the previous line and the two combined represent the entire Device Marking for that device.

(6) Lead/Ball Finish - Orderable Devices may have multiple material finish options. Finish options are separated by a vertical ruled line. Lead/Ball Finish values may wrap to two lines if the finish value exceeds the maximum column width.

Important Information and Disclaimer: The information provided on this page represents TI's knowledge and belief as of the date that it is provided. TI bases its knowledge and belief on information provided by third parties, and makes no representation or warranty as to the accuracy of such information. Efforts are underway to better integrate information from third parties. TI has taken and continues to take reasonable steps to provide representative and accurate information but may not have conducted destructive testing or chemical analysis on incoming materials and chemicals. TI and TI suppliers consider certain information to be proprietary, and thus CAS numbers and other limited information may not be available for release.

In no event shall TI's liability arising out of such information exceed the total purchase price of the TI part(s) at issue in this document sold by TI to Customer on an annual basis.

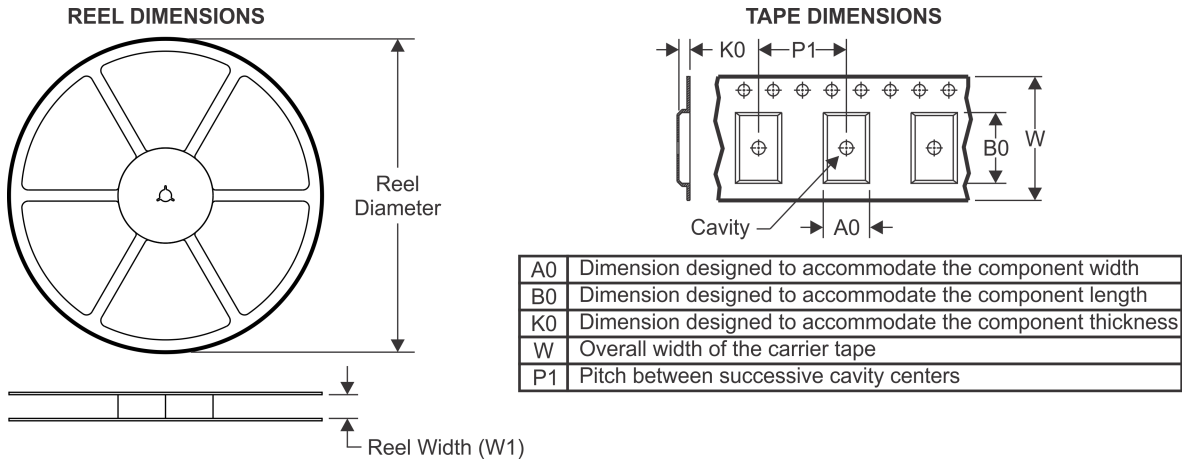
TAPE AND REEL INFORMATION

QUADRANT ASSIGNMENTS FOR PIN 1 ORIENTATION IN TAPE



*All dimensions are nominal

Device	Package Type	Package Drawing	Pins	SPQ	Reel Diameter (mm)	Reel Width W1 (mm)	A0 (mm)	B0 (mm)	K0 (mm)	P1 (mm)	W (mm)	Pin1 Quadrant
LM2682MM/NOPB	VSSOP	DGK	8	1000	178.0	12.4	5.3	3.4	1.4	8.0	12.0	Q1
LM2682MMX/NOPB	VSSOP	DGK	8	3500	330.0	12.4	5.3	3.4	1.4	8.0	12.0	Q1

TAPE AND REEL BOX DIMENSIONS

*All dimensions are nominal

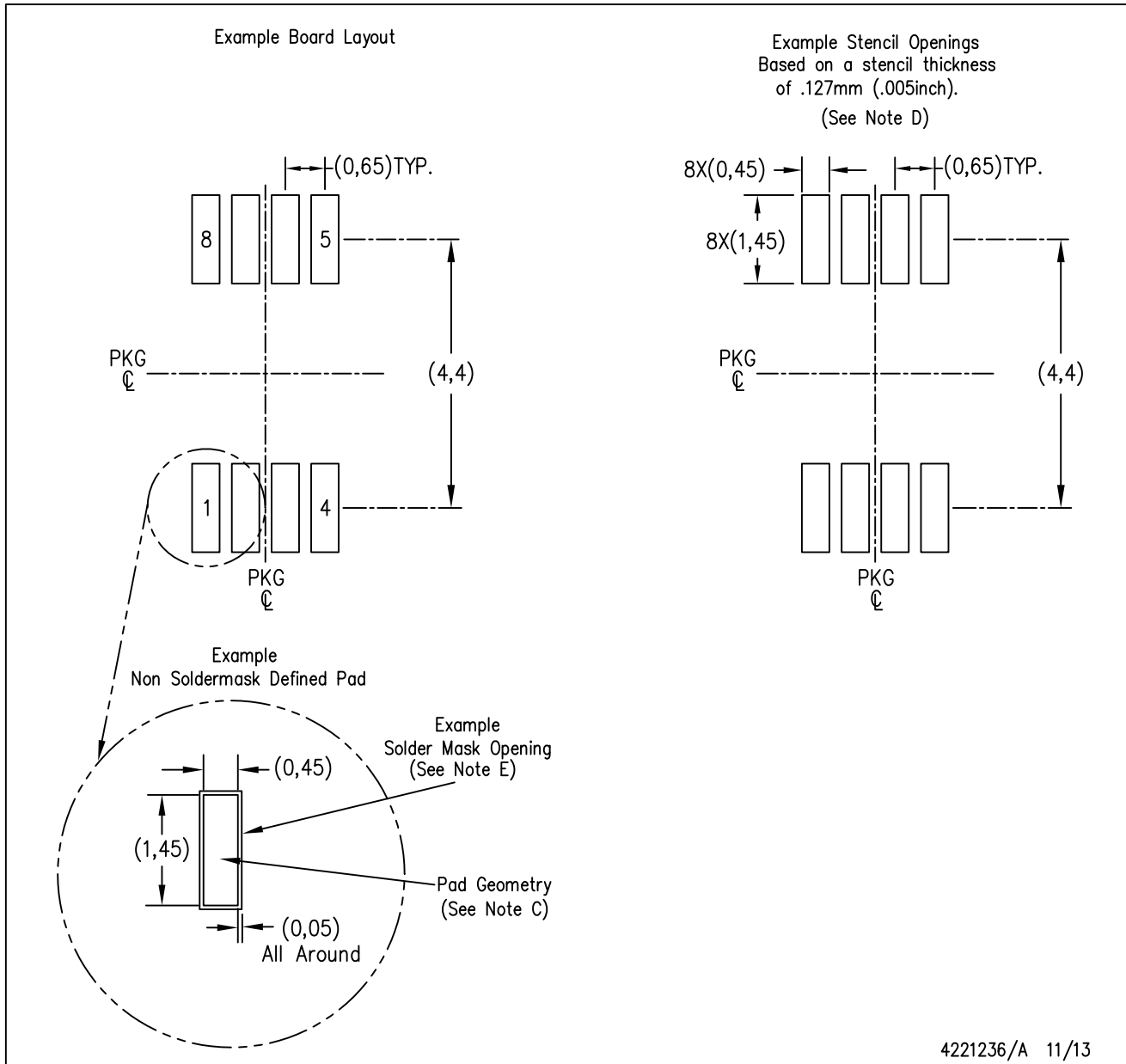
Device	Package Type	Package Drawing	Pins	SPQ	Length (mm)	Width (mm)	Height (mm)
LM2682MM/NOPB	VSSOP	DGK	8	1000	210.0	185.0	35.0
LM2682MMX/NOPB	VSSOP	DGK	8	3500	367.0	367.0	35.0



- NOTES:
- A. All linear dimensions are in millimeters.
 - B. This drawing is subject to change without notice.
 - C. Publication IPC-7351 is recommended for alternate designs.
 - D. Laser cutting apertures with trapezoidal walls and also rounding corners will offer better paste release. Customers should contact their board assembly site for stencil design recommendations. Refer to IPC-7525 for other stencil recommendations.
 - E. Customers should contact their board fabrication site for solder mask tolerances between and around signal pads.

IMPORTANT NOTICE

Texas Instruments Incorporated and its subsidiaries (TI) reserve the right to make corrections, enhancements, improvements and other changes to its semiconductor products and services per JESD46, latest issue, and to discontinue any product or service per JESD48, latest issue. Buyers should obtain the latest relevant information before placing orders and should verify that such information is current and complete. All semiconductor products (also referred to herein as "components") are sold subject to TI's terms and conditions of sale supplied at the time of order acknowledgment.

TI warrants performance of its components to the specifications applicable at the time of sale, in accordance with the warranty in TI's terms and conditions of sale of semiconductor products. Testing and other quality control techniques are used to the extent TI deems necessary to support this warranty. Except where mandated by applicable law, testing of all parameters of each component is not necessarily performed.

TI assumes no liability for applications assistance or the design of Buyers' products. Buyers are responsible for their products and applications using TI components. To minimize the risks associated with Buyers' products and applications, Buyers should provide adequate design and operating safeguards.

TI does not warrant or represent that any license, either express or implied, is granted under any patent right, copyright, mask work right, or other intellectual property right relating to any combination, machine, or process in which TI components or services are used. Information published by TI regarding third-party products or services does not constitute a license to use such products or services or a warranty or endorsement thereof. Use of such information may require a license from a third party under the patents or other intellectual property of the third party, or a license from TI under the patents or other intellectual property of TI.

Reproduction of significant portions of TI information in TI data books or data sheets is permissible only if reproduction is without alteration and is accompanied by all associated warranties, conditions, limitations, and notices. TI is not responsible or liable for such altered documentation. Information of third parties may be subject to additional restrictions.

Resale of TI components or services with statements different from or beyond the parameters stated by TI for that component or service voids all express and any implied warranties for the associated TI component or service and is an unfair and deceptive business practice. TI is not responsible or liable for any such statements.

Buyer acknowledges and agrees that it is solely responsible for compliance with all legal, regulatory and safety-related requirements concerning its products, and any use of TI components in its applications, notwithstanding any applications-related information or support that may be provided by TI. Buyer represents and agrees that it has all the necessary expertise to create and implement safeguards which anticipate dangerous consequences of failures, monitor failures and their consequences, lessen the likelihood of failures that might cause harm and take appropriate remedial actions. Buyer will fully indemnify TI and its representatives against any damages arising out of the use of any TI components in safety-critical applications.

In some cases, TI components may be promoted specifically to facilitate safety-related applications. With such components, TI's goal is to help enable customers to design and create their own end-product solutions that meet applicable functional safety standards and requirements. Nonetheless, such components are subject to these terms.

No TI components are authorized for use in FDA Class III (or similar life-critical medical equipment) unless authorized officers of the parties have executed a special agreement specifically governing such use.

Only those TI components which TI has specifically designated as military grade or "enhanced plastic" are designed and intended for use in military/aerospace applications or environments. Buyer acknowledges and agrees that any military or aerospace use of TI components which have **not** been so designated is solely at the Buyer's risk, and that Buyer is solely responsible for compliance with all legal and regulatory requirements in connection with such use.

TI has specifically designated certain components as meeting ISO/TS16949 requirements, mainly for automotive use. In any case of use of non-designated products, TI will not be responsible for any failure to meet ISO/TS16949.

Products

Audio	www.ti.com/audio
Amplifiers	amplifier.ti.com
Data Converters	dataconverter.ti.com
DLP® Products	www.dlp.com
DSP	dsp.ti.com
Clocks and Timers	www.ti.com/clocks
Interface	interface.ti.com
Logic	logic.ti.com
Power Mgmt	power.ti.com
Microcontrollers	microcontroller.ti.com
RFID	www.ti-rfid.com
OMAP Applications Processors	www.ti.com/omap
Wireless Connectivity	www.ti.com/wirelessconnectivity

Applications

Automotive and Transportation	www.ti.com/automotive
Communications and Telecom	www.ti.com/communications
Computers and Peripherals	www.ti.com/computers
Consumer Electronics	www.ti.com/consumer-apps
Energy and Lighting	www.ti.com/energy
Industrial	www.ti.com/industrial
Medical	www.ti.com/medical
Security	www.ti.com/security
Space, Avionics and Defense	www.ti.com/space-avionics-defense
Video and Imaging	www.ti.com/video

TI E2E Community

e2e.ti.com

Looking for pricing, stock, or lifecycle information?

Click below to explore more details on WIN SOURCE:

 [View LM2682MM/NOPB on WIN SOURCE](#)

 [Texas Instruments](#) Information

Optimize Your Supply Chain with WIN SOURCE Solutions

-  Global Sourcing Solution
-  Obsolete Management
-  Cost Control Management
-  Shortage Management
-  Alternative Solution
-  Excess Inventory Management