



THE DATASHEET OF LM2727MTCX/NOPB



LM2727/LM2737 N-Channel FET Synchronous Buck Regulator Controller for Low Output Voltages

 Check for Samples: [LM2727](#), [LM2737](#)

FEATURES

- Input Power from 2.2V to 16V
- Output Voltage Adjustable Down to 0.6V
- Power Good flag, Adjustable Soft-Start and Output Enable for Easy Power Sequencing
- Output Over-Voltage and Under-Voltage Latch-Off (LM2727)
- Output Over-Voltage and Under-Voltage Flag (LM2737)
- Reference Accuracy: 1.5% (0°C - 125°C)
- Current Limit Without Sense Resistor
- Soft Start
- Switching Frequency from 50 kHz to 2 MHz
- TSSOP-14 Package

APPLICATIONS

- Cable Modems
- Set-Top Boxes/ Home Gateways
- DDR Core Power
- High-Efficiency Distributed Power
- Local Regulation of Core Power

DESCRIPTION

The LM2727 and LM2737 are high-speed, synchronous, switching regulator controllers. They are intended to control currents of 0.7A to 20A with up to 95% conversion efficiencies. The LM2727 employs output over-voltage and under-voltage latch-off. For applications where latch-off is not desired, the LM2737 can be used. Power up and down sequencing is achieved with the power-good flag, adjustable soft-start and output enable features. The LM2727 and LM2737 operate from a low-current 5V bias and can convert from a 2.2V to 16V power rail. Both parts utilize a fixed-frequency, voltage-mode, PWM control architecture and the switching frequency is adjustable from 50kHz to 2MHz by adjusting the value of an external resistor. Current limit is achieved by monitoring the voltage drop across the on-resistance of the low-side MOSFET, which enhances low duty-cycle operation. The wide range of operating frequencies gives the power supply designer the flexibility to fine-tune component size, cost, noise and efficiency. The adaptive, non-overlapping MOSFET gate-drivers and high-side bootstrap structure helps to further maximize efficiency. The high-side power FET drain voltage can be from 2.2V to 16V and the output voltage is adjustable down to 0.6V.

Typical Application

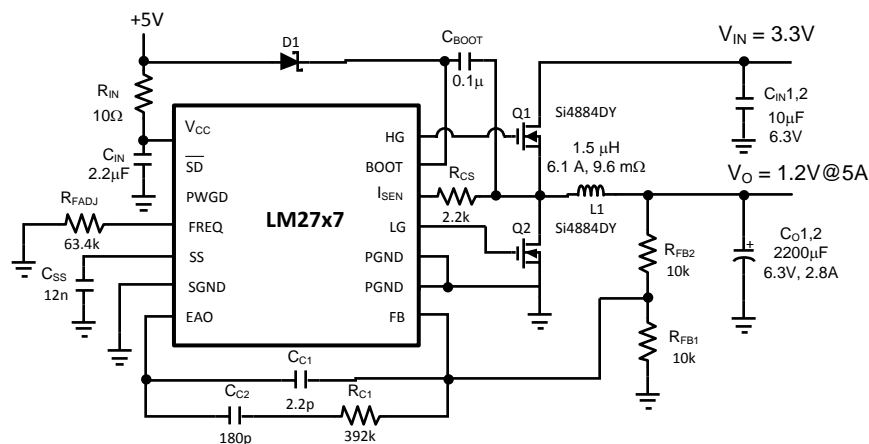

Please be aware that an important notice concerning availability, standard warranty, and use in critical applications of Texas Instruments semiconductor products and disclaimers thereto appears at the end of this data sheet.

All trademarks are the property of their respective owners.

Connection Diagram

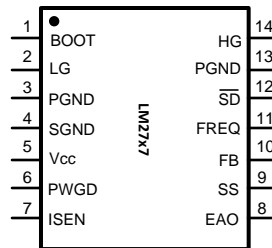

Figure 1. 14-Lead Plastic TSSOP
 $\theta_{JA} = 155^{\circ}\text{C/W}$
 See Package Number PW0014A

PIN DESCRIPTION

BOOT (Pin 1) - Supply rail for the N-channel MOSFET gate drive. The voltage should be at least one gate threshold above the regulator input voltage to properly turn on the high-side N-FET.
LG (Pin 2) - Gate drive for the low-side N-channel MOSFET. This signal is interlocked with HG to avoid shoot-through problems.
PGND (Pins 3, 13) - Ground for FET drive circuitry. It should be connected to system ground.
SGND (Pin 4) - Ground for signal level circuitry. It should be connected to system ground.
V_{CC} (Pin 5) - Supply rail for the controller.
PWGD (Pin 6) - Power Good. This is an open drain output. The pin is pulled low when the chip is in UVP, OVP, or UVLO mode. During normal operation, this pin is connected to V _{CC} or other voltage source through a pull-up resistor.
ISEN (Pin 7) - Current limit threshold setting. This sources a fixed 50 μ A current. A resistor of appropriate value should be connected between this pin and the drain of the low-side FET.
EAO (Pin 8) - Output of the error amplifier. The voltage level on this pin is compared with an internally generated ramp signal to determine the duty cycle. This pin is necessary for compensating the control loop.
SS (Pin 9) - Soft start pin. A capacitor connected between this pin and ground sets the speed at which the output voltage ramps up. Larger capacitor value results in slower output voltage ramp but also lower inrush current.
FB (Pin 10) - This is the inverting input of the error amplifier, which is used for sensing the output voltage and compensating the control loop.
FREQ (Pin 11) - The switching frequency is set by connecting a resistor between this pin and ground.
SD (Pin 12) - IC Logic Shutdown. When this pin is pulled low the chip turns off the high side switch and turns on the low side switch. While this pin is low, the IC will not start up. An internal 20 μ A pull-up connects this pin to V _{CC} .
HG (Pin 14) - Gate drive for the high-side N-channel MOSFET. This signal is interlocked with LG to avoid shoot-through problems.



These devices have limited built-in ESD protection. The leads should be shorted together or the device placed in conductive foam during storage or handling to prevent electrostatic damage to the MOS gates.

Absolute Maximum Ratings⁽¹⁾⁽²⁾

V _{CC}	7V
BOOTV	21V
Junction Temperature	150°C
Storage Temperature	-65°C to 150°C
Soldering Information	
Lead Temperature (soldering, 10sec)	260°C
Infrared or Convection (20sec)	235°C
ESD Rating ⁽³⁾	2 kV

- (1) Absolute maximum ratings indicate limits beyond which damage to the device may occur. **Operating ratings** indicate conditions for which the device operates correctly. **Operating Ratings** do not imply ensured performance limits.
- (2) If Military/Aerospace specified devices are required, please contact the Texas Instruments Sales Office/ Distributors for availability and specifications.
- (3) The human body model is a 100pF capacitor discharged through a 1.5k resistor into each pin.

Operating Ratings

Supply Voltage (V _{CC})	4.5V to 5.5V
Junction Temperature Range	-40°C to +125°C
Thermal Resistance (θ _{JA})	155°C/W

Electrical Characteristics

V_{CC} = 5V unless otherwise indicated. Typical and limits appearing in plain type apply for T_A=T_J=+25°C. Limits appearing in boldface type apply over full Operating Temperature Range. Datasheet min/max specification limits are ensured by design, test, or statistical analysis.

Symbol	Parameter	Conditions	Min	Typ	Max	Units
V _{FB_ADJ}	FB Pin Voltage	V _{CC} = 4.5V, 0°C to +125°C	0.591	0.6	0.609	V
		V _{CC} = 5V, 0°C to +125°C	0.591	0.6	0.609	
		V _{CC} = 5.5V, 0°C to +125°C	0.591	0.6	0.609	
		V _{CC} = 4.5V, -40°C to +125°C	0.589	0.6	0.609	
		V _{CC} = 5V, -40°C to +125°C	0.589	0.6	0.609	
		V _{CC} = 5.5V, -40°C to +125°C	0.589	0.6	0.609	
V _{ON}	UVLO Thresholds	Rising Falling		4.2 3.6		V
I _{Q-V5}	Operating V _{CC} Current	SD = 5V, FB = 0.55V Fsw = 600kHz	1	1.5	2	mA
		SD = 5V, FB = 0.65V Fsw = 600kHz	0.8	1.7	2.2	
	Shutdown V _{CC} Current	SD = 0V	0.15	0.4	0.7	mA
t _{PWGD1}	PWGD Pin Response Time	FB Voltage Going Up		6		µs
t _{PWGD2}	PWGD Pin Response Time	FB Voltage Going Down		6		µs
I _{SD}	SD Pin Internal Pull-up Current			20		µA
I _{SS-ON}	SS Pin Source Current	SS Voltage = 2.5V 0°C to +125°C	8	11	15	µA
		-40°C to +125°C	5	11	15	
I _{SS-OC}	SS Pin Sink Current During Over Current	SS Voltage = 2.5V		95		µA
I _{SEN-TH}	I _{SEN} Pin Source Current Trip Point	0°C to +125°C	35	50	65	µA
		-40°C to +125°C	28	50	65	

Electrical Characteristics (continued)

$V_{CC} = 5V$ unless otherwise indicated. Typical and limits appearing in plain type apply for $T_A = T_J = +25^\circ C$. Limits appearing in boldface type apply over full Operating Temperature Range. Datasheet min/max specification limits are ensured by design, test, or statistical analysis.

Symbol	Parameter	Conditions	Min	Typ	Max	Units
ERROR AMPLIFIER						
GBW	Error Amplifier Unity Gain Bandwidth			5		MHz
G	Error Amplifier DC Gain			60		dB
SR	Error Amplifier Slew Rate			6		V/ μ A
I_{FB}	FB Pin Bias Current	FB = 0.55V FB = 0.65V	0 0	15 30	100 155	nA
I_{EAO}	EAO Pin Current Sourcing and Sinking	$V_{EAO} = 2.5$, FB = 0.55V $V_{EAO} = 2.5$, FB = 0.65V		2.8 0.8		mA
V_{EA}	Error Amplifier Maximum Swing	Minimum Maximum		1.2 3.2		V
GATE DRIVE						
I_{Q-BOOT}	BOOT Pin Quiescent Current	BOOTV = 12V, EN = 0 0°C to +125°C -40°C to +125°C		95 95	160 215	μ A
R_{DS1}	Top FET Driver Pull-Up ON resistance	BOOT-SW = 5V@350mA		3		Ω
R_{DS2}	Top FET Driver Pull-Down ON resistance	BOOT-SW = 5V@350mA		2		Ω
R_{DS3}	Bottom FET Driver Pull-Up ON resistance	BOOT-SW = 5V@350mA		3		Ω
R_{DS4}	Bottom FET Driver Pull-Down ON resistance	BOOT-SW = 5V@350mA		2		Ω
OSCILLATOR						
f_{OSC}	PWM Frequency	$R_{FADJ} = 590k\Omega$		50		kHz
		$R_{FADJ} = 88.7k\Omega$		300		
		$R_{FADJ} = 42.2k\Omega$, 0°C to +125°C	500	600	700	
		$R_{FADJ} = 42.2k\Omega$, -40°C to +125°C	490	600	700	
		$R_{FADJ} = 17.4k\Omega$		1400		
		$R_{FADJ} = 11.3k\Omega$		2000		
D	Max Duty Cycle	$f_{PWM} = 300kHz$ $f_{PWM} = 600kHz$		90 88		%
LOGIC INPUTS AND OUTPUTS						
V_{SD-IH}	SD Pin Logic High Trip Point			2.6	3.5	V
V_{SD-IL}	SD Pin Logic Low Trip Point	0°C to +125°C -40°C to +125°C	1.3 1.25	1.6 1.6		V
$V_{PWGD-TH-LO}$	PWGD Pin Trip Points	FB Voltage Going Down 0°C to +125°C -40°C to +125°C	0.413 0.410	0.430 0.430	0.446 0.446	V
$V_{PWGD-TH-HI}$	PWGD Pin Trip Points	FB Voltage Going Up 0°C to +125°C -40°C to +125°C	0.691 0.688	0.710 0.710	0.734 0.734	V
$V_{PWGD-HYS}$	PWGD Hysteresis (LM2737 only)	FB Voltage Going Down FB Voltage Going Up		35 110		mV

Typical Performance Characteristics

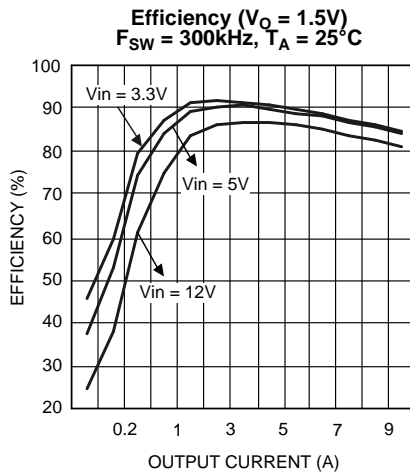

Figure 2.

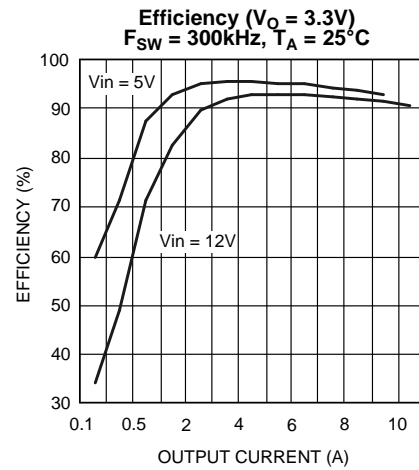

Figure 3.

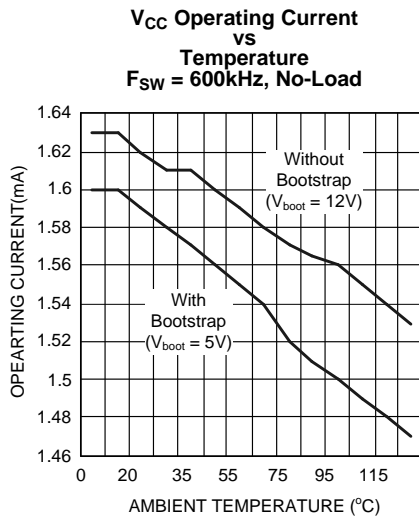

Figure 4.

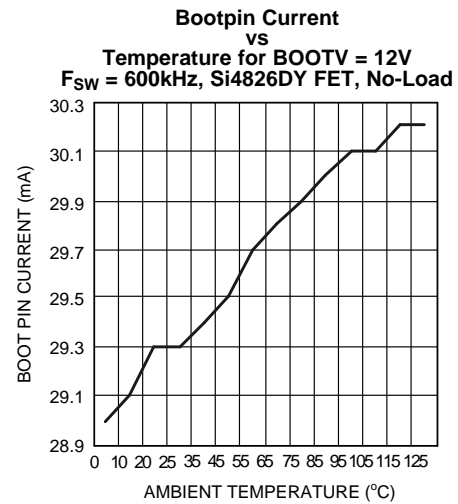

Figure 5.

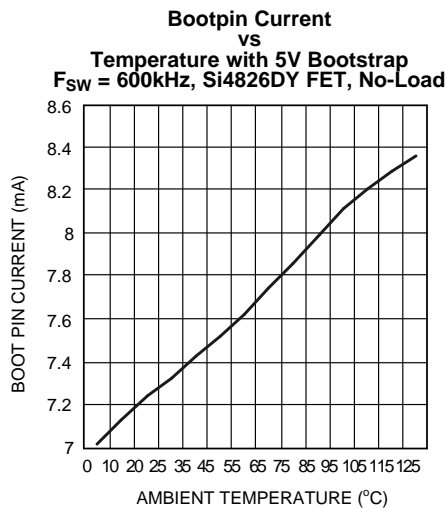

Figure 6.

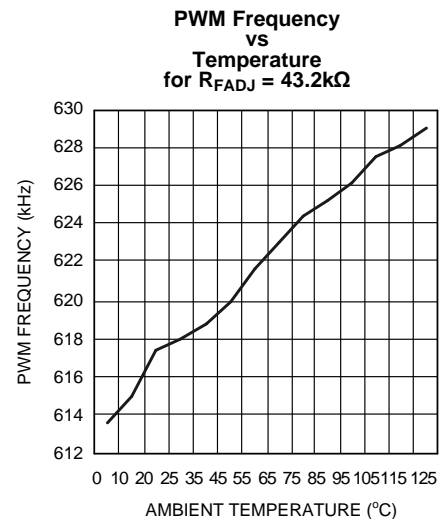

Figure 7.

Typical Performance Characteristics (continued)

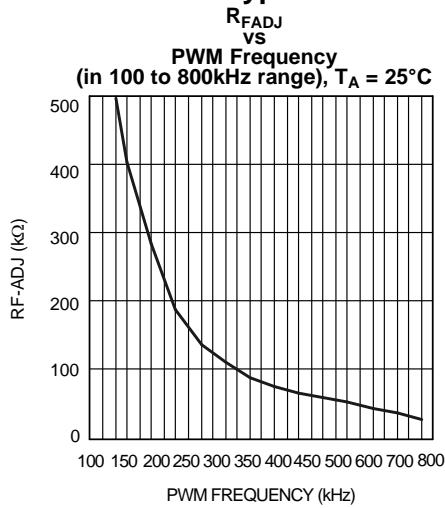

Figure 8.

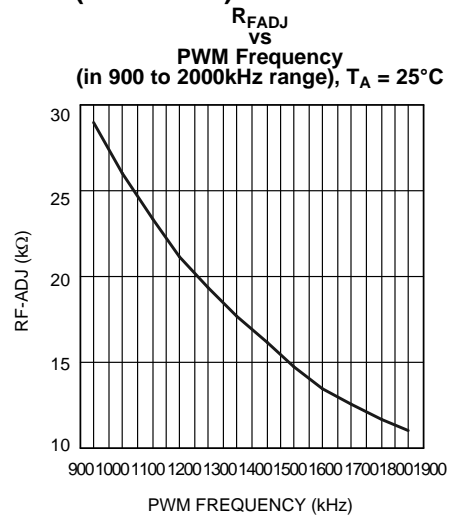

Figure 9.

V_{CC} Operating Current Plus Boot Current vs PWM Frequency (Si4826DY FET, $T_A = 25^\circ\text{C}$)

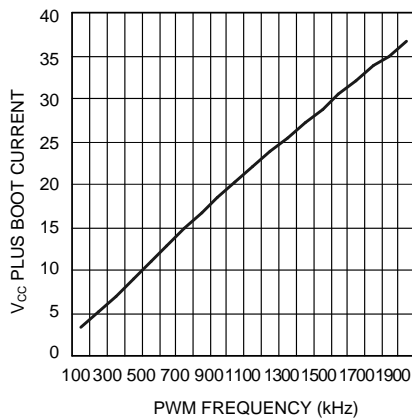

Figure 10.

Switch Waveforms (HG Falling)

$V_{IN} = 5\text{V}$, $V_O = 1.8\text{V}$
 $I_O = 3\text{A}$, $C_{SS} = 10\text{nF}$
 $F_{SW} = 600\text{kHz}$

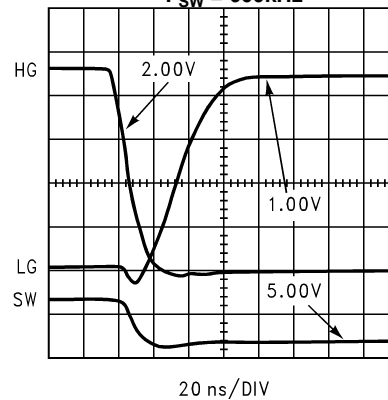

Figure 11.

Switch Waveforms (HG Rising)

$V_{IN} = 5\text{V}$, $V_O = 1.8\text{V}$
 $I_O = 3\text{A}$, $F_{SW} = 600\text{kHz}$

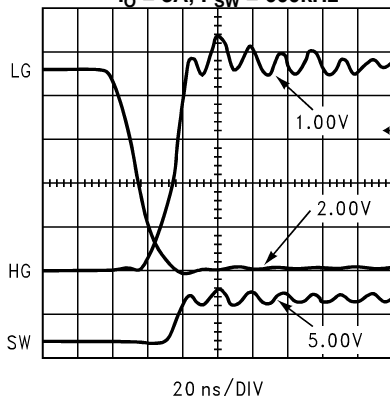

Figure 12.

Start-Up (No-Load)

$V_{IN} = 10\text{V}$, $V_O = 1.2\text{V}$
 $C_{SS} = 10\text{nF}$, $F_{SW} = 300\text{kHz}$

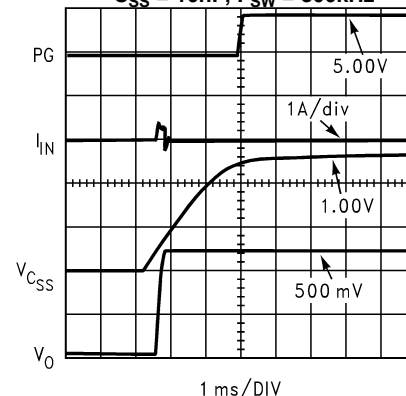
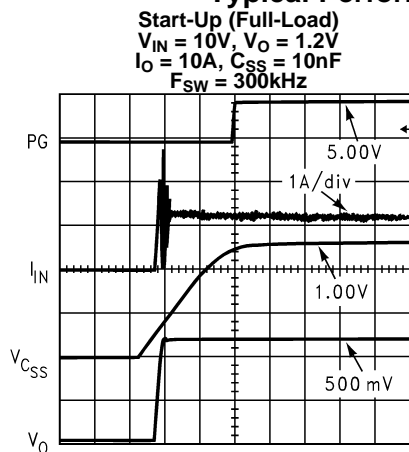
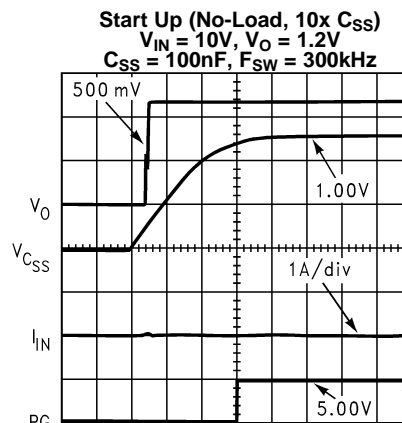

Figure 13.

Typical Performance Characteristics (continued)



1 ms/DIV
Figure 14.



10 ms/DIV
Figure 15.

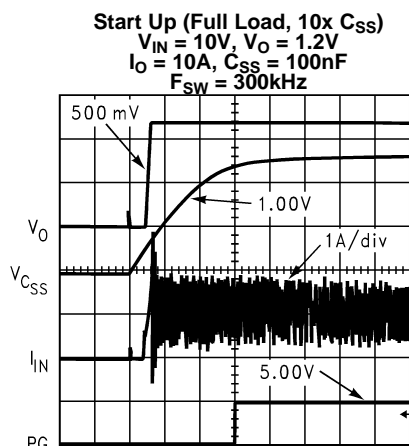

10 ms/DIV
Figure 16.

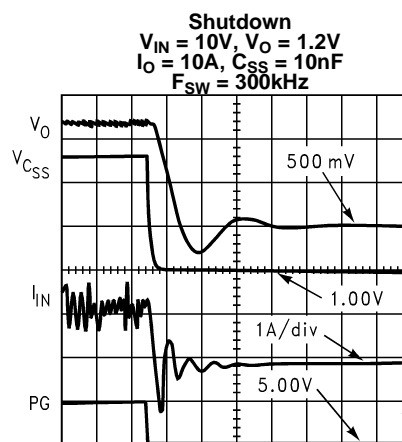

40 μs/DIV
Figure 17.

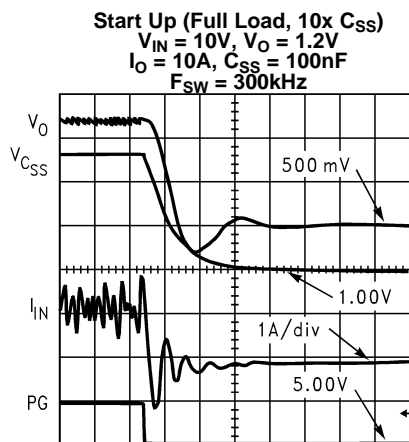

40 μs/DIV
Figure 18.

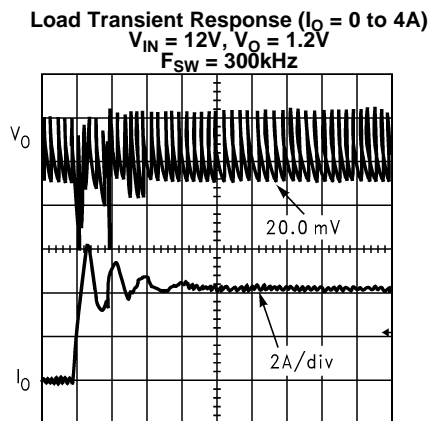

20 μs/DIV
Figure 19.

Typical Performance Characteristics (continued)

Load Transient Response ($I_O = 4$ to $0A$)
 $V_{IN} = 12V, V_O = 1.2V$
 $F_{SW} = 300kHz$

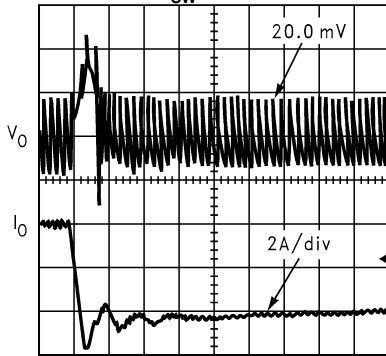

20 μs /DIV
 Figure 20.

Line Transient Response ($V_{IN} = 5V$ to $12V$)
 $V_O = 1.2V, I_O = 5A$
 $F_{SW} = 300kHz$

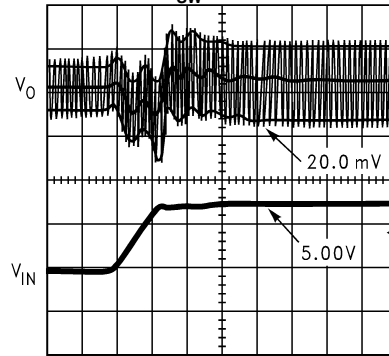

40 μs /DIV
 Figure 21.

Line Transient Response ($V_{IN} = 12V$ to $5V$)
 $V_O = 1.2V, I_O = 5A$
 $F_{SW} = 300kHz$

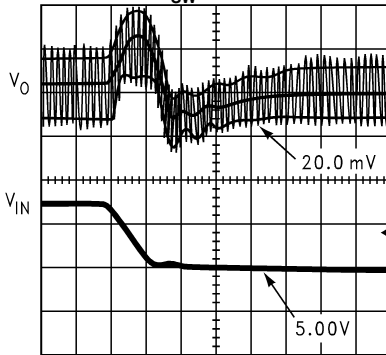

40 μs /DIV
 Figure 22.

Line Transient Response
 $V_O = 1.2V, I_O = 5A$
 $F_{SW} = 300kHz$

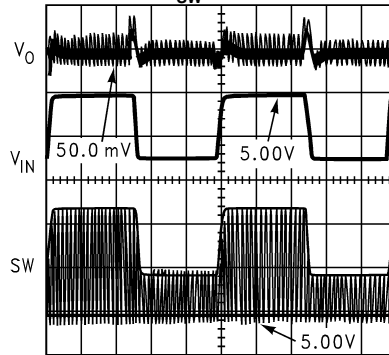

400 μs /DIV
 Figure 23.

Block Diagram

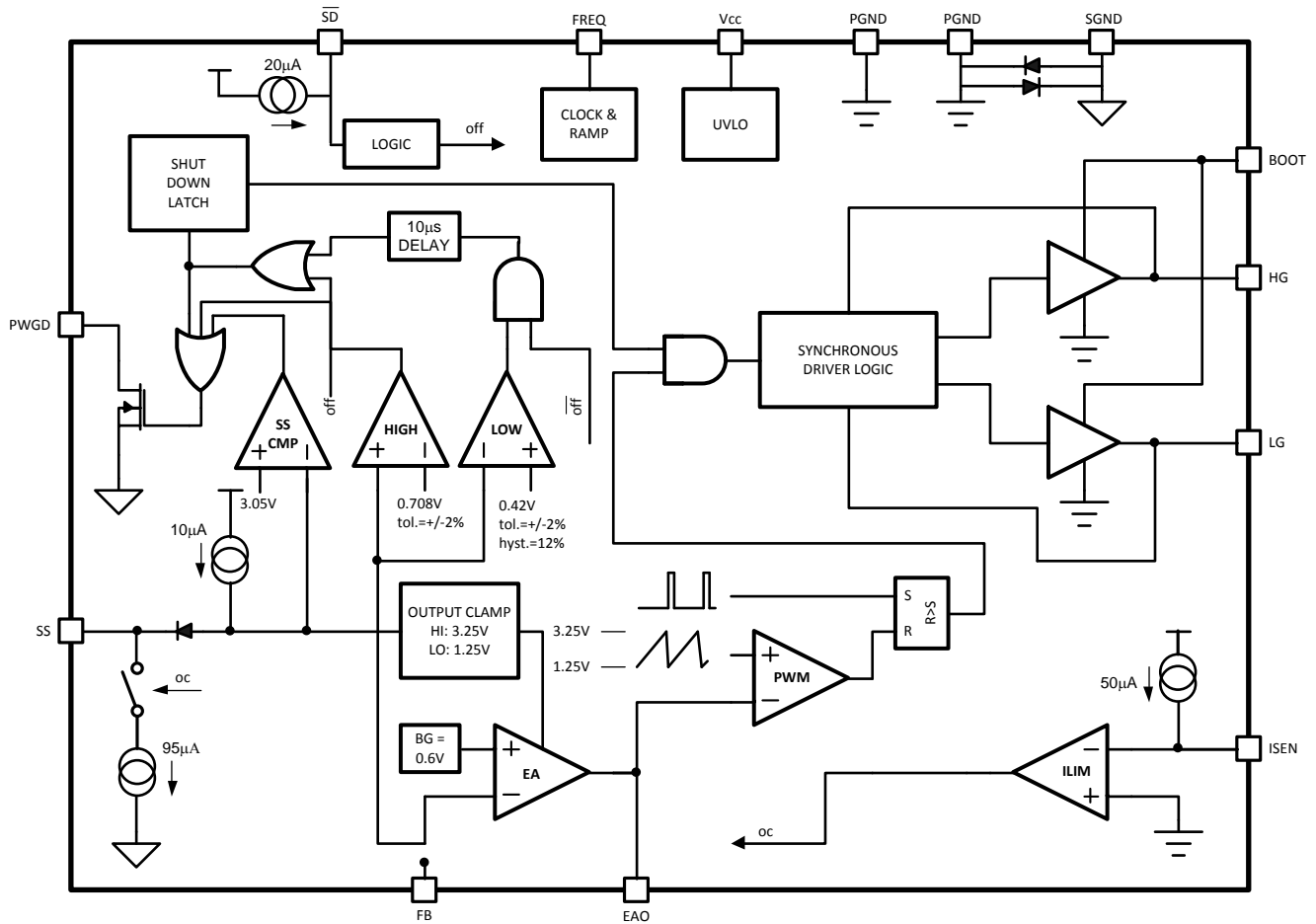

APPLICATION INFORMATION

THEORY OF OPERATION

The LM2727 is a voltage-mode, high-speed synchronous buck regulator with a PWM control scheme. It is designed for use in set-top boxes, thin clients, DSL/Cable modems, and other applications that require high efficiency buck converters. It has power good (PWRGD), output shutdown (SD), over voltage protection (OVP) and under voltage protection (UVP). The over-voltage and under-voltage signals are OR gated to drive the Power Good signal and a shutdown latch, which turns off the high side gate and turns on the low side gate if pulled low. Current limit is achieved by sensing the voltage V_{DS} across the low side FET. During current limit the high side gate is turned off and the low side gate turned on. The soft start capacitor is discharged by a $95\mu\text{A}$ source (reducing the maximum duty cycle) until the current is under control. The LM2737 does not latch off during UVP or OVP, and uses the HIGH and LOW comparators for the powergood function only.

START UP

When V_{CC} exceeds 4.2V and the enable pin EN sees a logic high the soft start capacitor begins charging through an internal fixed $10\mu\text{A}$ source. During this time the output of the error amplifier is allowed to rise with the voltage of the soft start capacitor. This capacitor, C_{SS} , determines soft start time, and can be determined approximately by:

$$C_{SS} = \frac{t_{ss}}{2.5 \times 10^5} \quad (1)$$

An application for a microprocessor might need a delay of 3ms, in which case C_{SS} would be 12nF. For a different device, a 100ms delay might be more appropriate, in which case C_{SS} would be 400nF. (390 10%) During soft start the PWRGD flag is forced low and is released when the voltage reaches a set value. At this point this chip enters normal operation mode, the Power Good flag is released, and the OVP and UVP functions begin to monitor V_o .

NORMAL OPERATION

While in normal operation mode, the LM2727/37 regulates the output voltage by controlling the duty cycle of the high side and low side FETs. The equation governing output voltage is:

$$0.6 = \frac{R_{FB1}}{R_{FB1} + R_{FB2}} V_o \quad (2)$$

The PWM frequency is adjustable between 50kHz and 2MHz and is set by an external resistor, R_{FADJ} , between the FREQ pin and ground. The resistance needed for a desired frequency is approximately:

$$R_{FADJ} = \left(\frac{20500}{\text{freq}[\text{kHz}]} \right)^{1.0526} \text{ k}\Omega \quad (3)$$

MOSFET GATE DRIVERS

The LM2727/37 has two gate drivers designed for driving N-channel MOSFETs in a synchronous mode. Power for the drivers is supplied through the BOOTV pin. For the high side gate (HG) to fully turn on the top FET, the BOOTV voltage must be at least one $V_{GS(th)}$ greater than V_{in} . ($\text{BOOTV} \geq 2 \cdot V_{in}$) This voltage can be supplied by a separate, higher voltage source, or supplied from a local charge pump structure. In a system such as a desktop computer, both 5V and 12V are usually available. Hence if V_{in} was 5V, the 12V supply could be used for BOOTV. 12V is more than $2 \cdot V_{in}$, so the HG would operate correctly. For a BOOTV of 12V, the initial gate charging current is 2A, and the initial gate discharging current is typically 6A.

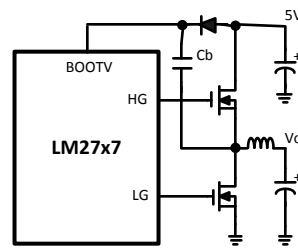

Figure 24. BOOTV Supplied by Charge Pump

In a system without a separate, higher voltage, a charge pump (bootstrap) can be built using a diode and small capacitor, [Figure 24](#). The capacitor serves to maintain enough voltage between the top FET gate and source to control the device even when the top FET is on and its source has risen up to the input voltage level.

The LM2727/37 gate drivers use a BiCMOS design. Unlike some other bipolar control ICs, the gate drivers have rail-to-rail swing, ensuring no spurious turn-on due to capacitive coupling.

POWER GOOD SIGNAL

The power good signal is the or-gated flag representing over-voltage and under-voltage protection. If the output voltage is 18% over its nominal value, $V_{FB} = 0.7V$, or falls 30% below that value, $V_{FB} = 0.41V$, the power good flag goes low. The converter then turns off the high side gate, and turns on the low side gate. Unlike the output (LM2727 only) the power good flag is not latched off. It will return to a logic high whenever the feedback pin voltage is between 70% and 118% of 0.6V.

UVLO

The 4.2V turn-on threshold on V_{CC} has a built in hysteresis of 0.6V. Therefore, if V_{CC} drops below 3.6V, the chip enters UVLO mode. UVLO consists of turning off the top FET, turning on the bottom FET, and remaining in that condition until V_{CC} rises above 4.2V. As with shutdown, the soft start capacitor is discharged through a FET, ensuring that the next start-up will be smooth.

CURRENT LIMIT

Current limit is realized by sensing the voltage across the low side FET while it is on. The $R_{DS(on)}$ of the FET is a known value, hence the current through the FET can be determined as:

$$V_{DS} = I * R_{DS(on)} \quad (4)$$

The current limit is determined by an external resistor, R_{CS} , connected between the switch node and the ISEN pin. A constant current of 50 μ A is forced through R_{CS} , causing a fixed voltage drop. This fixed voltage is compared against V_{DS} and if the latter is higher, the current limit of the chip has been reached. R_{CS} can be found by using the following:

$$R_{CS} = R_{DS(on)(LOW)} * I_{LIM}/50\mu A \quad (5)$$

For example, a conservative 15A current limit in a 10A design with a minimum $R_{DS(on)}$ of 10m Ω would require a 3.3k Ω resistor. Because current sensing is done across the low side FET, no minimum high side on-time is necessary. In the current limit mode the LM2727/37 will turn the high side off and keep low side on for as long as necessary. The chip also discharges the soft start capacitor through a fixed 95 μ A source. In this way, smooth ramping up of the output voltage as with a normal soft start is ensured. The output of the LM2727/37 internal error amplifier is limited by the voltage on the soft start capacitor. Hence, discharging the soft start capacitor reduces the maximum duty cycle D of the controller. During severe current limit, this reduction in duty cycle will reduce the output voltage, if the current limit conditions lasts for an extended time.

During the first few nanoseconds after the low side gate turns on, the low side FET body diode conducts. This causes an additional 0.7V drop in V_{DS} . The range of V_{DS} is normally much lower. For example, if $R_{DS(on)}$ were 10m Ω and the current through the FET was 10A, V_{DS} would be 0.1V. The current limit would see 0.7V as a 70A current and enter current limit immediately. Hence current limit is masked during the time it takes for the high side switch to turn off and the low side switch to turn on.

UVP/OVP

The output undervoltage protection and overvoltage protection mechanisms engage at 70% and 118% of the target output voltage, respectively. In either case, the LM2727 will turn off the high side switch and turn on the low side switch, and discharge the soft start capacitor through a MOSFET switch. The chip remains in this state until the shutdown pin has been pulled to a logic low and then released. The UVP function is masked only during the first charging of the soft start capacitor, when voltage is first applied to the V_{CC} pin. In contrast, the LM2737 is designed to continue operating during UVP or OVP conditions, and to resume normal operation once the fault condition is cleared. As with the LM2727, the powergood flag goes low during this time, giving a logic-level warning signal.

SHUT DOWN

If the shutdown pin SD is pulled low, the LM2727/37 discharges the soft start capacitor through a MOSFET switch. The high side switch is turned off and the low side switch is turned on. The LM2727/37 remains in this state until \overline{SD} is released.

DESIGN CONSIDERATIONS

The following is a design procedure for all the components needed to create the circuit shown in [Figure 26](#) in the Example Circuits section, a 5V in to 1.2V out converter, capable of delivering 10A with an efficiency of 85%. The switching frequency is 300kHz. The same procedures can be followed to create the circuit shown in [Figure 26](#), [Figure 27](#), and to create many other designs with varying input voltages, output voltages, and output currents.

INPUT CAPACITOR

The input capacitors in a Buck switching converter are subjected to high stress due to the input current waveform, which is a square wave. Hence input caps are selected for their ripple current capability and their ability to withstand the heat generated as that ripple current runs through their ESR. Input rms ripple current is approximately:

$$I_{\text{rms_rip}} = I_o * \sqrt{D(1 - D)} \quad (6)$$

The power dissipated by each input capacitor is:

$$P_D = \frac{I_{\text{rms_rip}}^2 * \text{ESR}}{n^2} \quad (7)$$

Here, n is the number of capacitors, and indicates that power loss in each cap decreases rapidly as the number of input caps increase. The worst-case ripple for a Buck converter occurs during full load, when the duty cycle D = 50%.

In the 5V to 1.2V case, $D = 1.2/5 = 0.24$. With a 10A maximum load the ripple current is 4.3A. The Sanyo 10MV5600AX aluminum electrolytic capacitor has a ripple current rating of 2.35A, up to 105°C. Two such capacitors make a conservative design that allows for unequal current sharing between individual caps. Each capacitor has a maximum ESR of 18mΩ at 100 kHz. Power loss in each device is then 0.05W, and total loss is 0.1W. Other possibilities for input and output capacitors include MLCC, tantalum, OSCON, SP, and POSCAPS.

INPUT INDUCTOR

The input inductor serves two basic purposes. First, in high power applications, the input inductor helps insulate the input power supply from switching noise. This is especially important if other switching converters draw current from the same supply. Noise at high frequency, such as that developed by the LM2727 at 1MHz operation, could pass through the input stage of a slower converter, contaminating and possibly interfering with its operation.

An input inductor also helps shield the LM2727 from high frequency noise generated by other switching converters. The second purpose of the input inductor is to limit the input current slew rate. During a change from no-load to full-load, the input inductor sees the highest voltage change across it, equal to the full load current times the input capacitor ESR. This value divided by the maximum allowable input current slew rate gives the minimum input inductance:

$$L_{in} = \frac{\Delta V}{\left(\frac{di}{dt}\right)_{max}} \quad (8)$$

In the case of a desktop computer system, the input current slew rate is the system power supply or "silver box" output current slew rate, which is typically about 0.1A/μs. Total input capacitor ESR is 9mΩ, hence ΔV is 10*0.009 = 90 mV, and the minimum inductance required is 0.9μH. The input inductor should be rated to handle the DC input current, which is approximated by:

$$I_{IN-DC} = \frac{I_o * D}{\eta} \quad (9)$$

In this case I_{IN-DC} is about 2.8A. One possible choice is the TDK SLF12575T-1R2N8R2, a 1.2μH device that can handle 8.2Arms, and has a DCR of 7mΩ.

OUTPUT INDUCTOR

The output inductor forms the first half of the power stage in a Buck converter. It is responsible for smoothing the square wave created by the switching action and for controlling the output current ripple. (ΔI_o) The inductance is chosen by selecting between tradeoffs in efficiency and response time. The smaller the output inductor, the more quickly the converter can respond to transients in the load current. As shown in the efficiency calculations, however, a smaller inductor requires a higher switching frequency to maintain the same level of output current ripple. An increase in frequency can mean increasing loss in the FETs due to the charging and discharging of the gates. Generally the switching frequency is chosen so that conduction loss outweighs switching loss. The equation for output inductor selection is:

$$L = \frac{V_{in} - V_o}{\Delta i_o * F_{SW}} * D \quad (10)$$

Plugging in the values for output current ripple, input voltage, output voltage, switching frequency, and assuming a 40% peak-to-peak output current ripple yields an inductance of 1.5μH. The output inductor must be rated to handle the peak current (also equal to the peak switch current), which is $(I_o + 0.5*\Delta I_o)$. This is 12A for a 10A design. The Coilcraft D05022-152HC is 1.5μH, is rated to 15Arms, and has a DCR of 4mΩ.

OUTPUT CAPACITOR

The output capacitor forms the second half of the power stage of a Buck switching converter. It is used to control the output voltage ripple (ΔV_o) and to supply load current during fast load transients.

In this example the output current is 10A and the expected type of capacitor is an aluminum electrolytic, as with the input capacitors. (Other possibilities include ceramic, tantalum, and solid electrolyte capacitors, however the ceramic type often do not have the large capacitance needed to supply current for load transients, and tantalums tend to be more expensive than aluminum electrolytic.) Aluminum capacitors tend to have very high capacitance and fairly low ESR, meaning that the ESR zero, which affects system stability, will be much lower than the switching frequency. The large capacitance means that at switching frequency, the ESR is dominant, hence the type and number of output capacitors is selected on the basis of ESR. One simple formula to find the maximum ESR based on the desired output voltage ripple, ΔV_o , and the designed output current ripple, ΔI_o , is:

$$ESR_{MAX} = \frac{\Delta V_o}{\Delta I_o} \quad (11)$$

In this example, in order to maintain a 2% peak-to-peak output voltage ripple and a 40% peak-to-peak inductor current ripple, the required maximum ESR is 6mΩ. Three Sanyo 10MV5600AX capacitors in parallel will give an equivalent ESR of 6mΩ. The total bulk capacitance of 16.8mF is enough to supply even severe load transients. Using the same capacitors for both input and output also keeps the bill of materials simple.

MOSFETS

MOSFETS are a critical part of any switching controller and have a direct impact on the system efficiency. In this case the target efficiency is 85% and this is the variable that will determine which devices are acceptable. Loss from the capacitors, inductors, and the LM2727 itself are detailed in the Efficiency section, and come to about 0.54W. To meet the target efficiency, this leaves 1.45W for the FET conduction loss, gate charging loss, and switching loss. Switching loss is particularly difficult to estimate because it depends on many factors. When the load current is more than about 1 or 2 amps, conduction losses outweigh the switching and gate charging losses. This allows FET selection based on the $R_{\text{DS(on)}}$ of the FET. Adding the FET switching and gate-charging losses to the equation leaves 1.2W for conduction losses. The equation for conduction loss is:

$$P_{\text{Cnd}} = D(I_o^2 * R_{\text{DS(on)}} * k) + (1-D)(I_o^2 * R_{\text{DS(on)}} * k) \quad (12)$$

The factor k is a constant which is added to account for the increasing $R_{\text{DS(on)}}$ of a FET due to heating. Here, $k = 1.3$. The Si4442DY has a typical $R_{\text{DS(on)}}$ of 4.1m Ω . When plugged into the equation for P_{CND} the result is a loss of 0.533W. If this design were for a 5V to 2.5V circuit, an equal number of FETs on the high and low sides would be the best solution. With the duty cycle $D = 0.24$, it becomes apparent that the low side FET carries the load current 76% of the time. Adding a second FET in parallel to the bottom FET could improve the efficiency by lowering the effective $R_{\text{DS(on)}}$. The lower the duty cycle, the more effective a second or even third FET can be. For a minimal increase in gate charging loss (0.054W) the decrease in conduction loss is 0.15W. What was an 85% design improves to 86% for the added cost of one SO-8 MOSFET.

CONTROL LOOP COMPONENTS

The circuit in this design example and the others shown in the Example Circuits section have been compensated to improve their DC gain and bandwidth. The result of this compensation is better line and load transient responses. For the LM2727, the top feedback divider resistor, R_{fb2} , is also a part of the compensation. For the 10A, 5V to 1.2V design, the values are:

$C_{c1} = 4.7\text{pF}$ 10%, $C_{c2} = 1\text{nF}$ 10%, $R_c = 229\text{k}\Omega$ 1%. These values give a phase margin of 63° and a bandwidth of 29.3kHz.

SUPPORT CAPACITORS AND RESISTORS

The C_{inx} capacitors are high frequency bypass devices, designed to filter harmonics of the switching frequency and input noise. Two 1 μF ceramic capacitors with a sufficient voltage rating (10V for the Circuit of [Figure 26](#)) will work well in almost any case.

R_{bypass} and C_{bypass} are standard filter components designed to ensure smooth DC voltage for the chip supply and for the bootstrap structure, if it is used. Use 10 Ω for the resistor and a 2.2 μF ceramic for the cap. C_b is the bootstrap capacitor, and should be 0.1 μF . (In the case of a separate, higher supply to the BOOTV pin, this 0.1 μF cap can be used to bypass the supply.) Using a Schottky device for the bootstrap diode allows the minimum drop for both high and low side drivers. The On Semiconductor BAT54 or MBR0520 work well.

R_p is a standard pull-up resistor for the open-drain power good signal, and should be 10k Ω . If this feature is not necessary, it can be omitted.

R_{CS} is the resistor used to set the current limit. Since the design calls for a peak current magnitude ($I_o + 0.5 * \Delta I_o$) of 12A, a safe setting would be 15A. (This is well below the saturation current of the output inductor, which is 25A.) Following the equation from the Current Limit section, use a 3.3k Ω resistor.

R_{FADJ} is used to set the switching frequency of the chip. Following the equation in the Theory of Operation section, the closest 1% tolerance resistor to obtain $f_{\text{sw}} = 300\text{kHz}$ is 88.7k Ω .

C_{SS} depends on the users requirements. Based on the equation for C_{SS} in the Theory of Operation section, for a 3ms delay, a 12nF capacitor will suffice.

EFFICIENCY CALCULATIONS

A reasonable estimation of the efficiency of a switching controller can be obtained by adding together the loss in each current carrying element and using the equation:

$$\eta = \frac{P_o}{P_o + P_{\text{total-loss}}} \quad (13)$$

The following shows an efficiency calculation to complement the Circuit of [Figure 26](#). Output power for this circuit is $1.2V \times 10A = 12W$.

Chip Operating Loss

$$P_{IQ} = I_{Q-VCC} * V_{CC} \quad (14)$$

$$2mA \times 5V = 0.01W$$

FET Gate Charging Loss

$$P_{GC} = n * V_{CC} * Q_{GS} * f_{OSC} \quad (15)$$

The value n is the total number of FETs used. The Si4442DY has a typical total gate charge, Q_{GS} , of 36nC and an r_{ds-on} of 4.1mΩ. For a single FET on top and bottom: $2 * 5 * 36E^{-9} * 300,000 = 0.108W$

FET Switching Loss

$$P_{SW} = 0.5 * V_{in} * I_o * (t_r + t_f) * f_{OSC} \quad (16)$$

The Si4442DY has a typical rise time t_r and fall time t_f of 11 and 47ns, respectively. $0.5 * 5 * 10 * 58E^{-9} * 300,000 = 0.435W$

FET Conduction Loss

$$P_{Cn} = 0.533W \quad (17)$$

Input Capacitor Loss

$$P_{Cin} = \frac{I_{rms-rip}^2 * ESR}{n} \quad (18)$$

$$I_{rms-rip} = I_o * \sqrt{D(1-D)} \quad (19)$$

$$4.28^2 * 0.018 / 2 = 0.084W$$

Input Inductor Loss

$$P_{Lin} = I_{in}^2 * DCR_{input-L} \quad (20)$$

$$I_{IN} = \frac{I_o * D}{\eta_{est'd}} \quad (21)$$

$$2.82^2 * 0.007 = 0.055W$$

Output Inductor Loss

$$P_{Lout} = I_o^2 * DCR_{output-L} \quad (22)$$

$$10^2 * 0.004 = 0.4W$$

System Efficiency

$$\frac{12}{12 + 1.625} = 88\% \quad (23)$$

Example Circuits

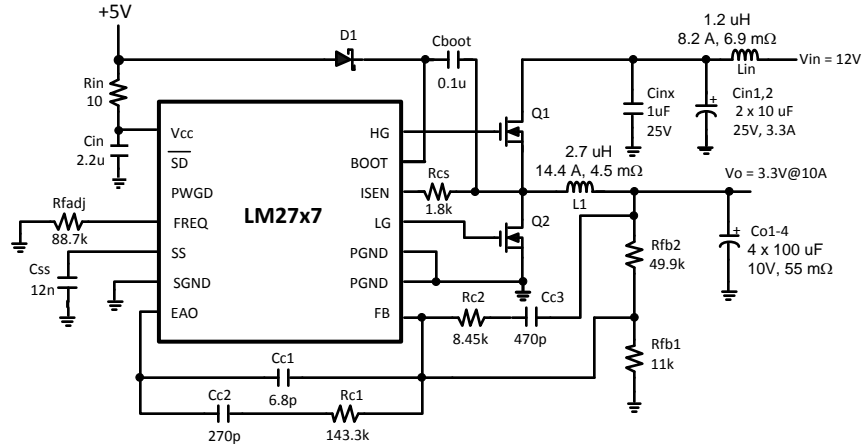

Figure 25. 5V-16V to 3.3V, 10A, 300kHz

This circuit and the one featured on the front page have been designed to deliver high current and high efficiency in a small package, both in area and in height. The tallest component in this circuit is the inductor L1, which is 6mm tall. The compensation has been designed to tolerate input voltages from 5 to 16V.

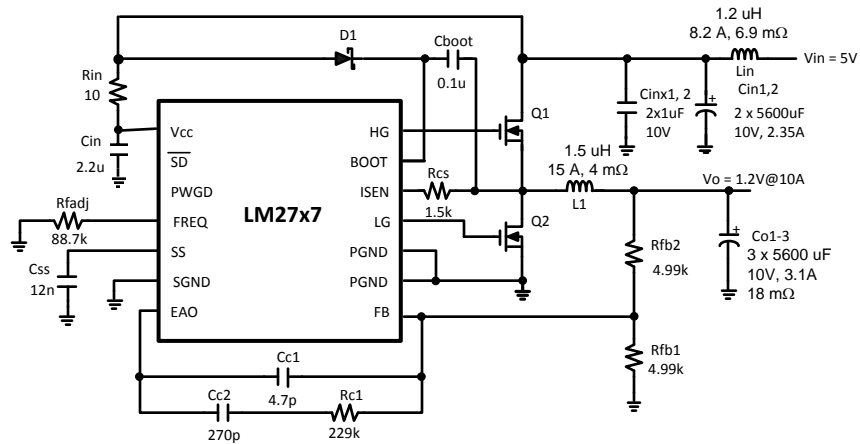

Figure 26. 5V to 1.2V, 10A, 300kHz

This circuit design, detailed in the Design Considerations section, uses inexpensive aluminum capacitors and off-the-shelf inductors. It can deliver 10A at better than 85% efficiency. Large bulk capacitance on input and output ensure stable operation.

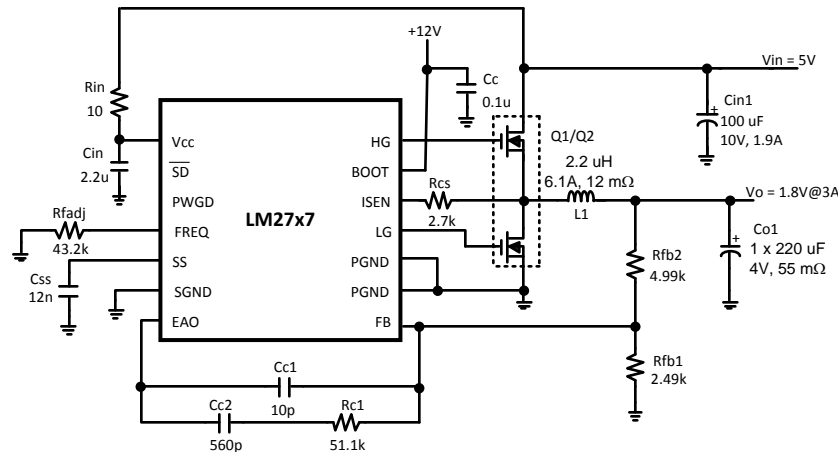

Figure 27. 5V to 1.8V, 3A, 600kHz

The example circuit of Figure 27 has been designed for minimum component count and overall solution size. A switching frequency of 600kHz allows the use of small input/output capacitors and a small inductor. The availability of separate 5V and 12V supplies (such as those available from desk-top computer supplies) and the low current further reduce component count. Using the 12V supply to power the MOSFET drivers eliminates the bootstrap diode, D1. At low currents, smaller FETs or dual FETs are often the most efficient solutions. Here, the Si4826DY, an asymmetric dual FET in an SO-8 package, yields 92% efficiency at a load of 2A.

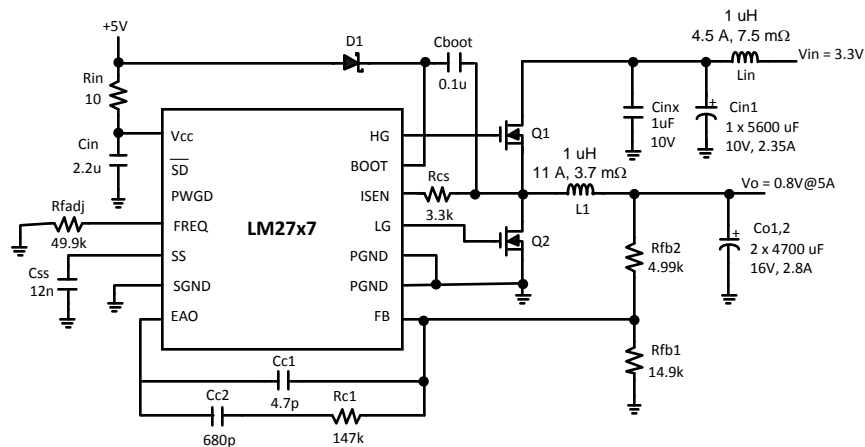

Figure 28. 3.3V to 0.8V, 5A, 500kHz

The circuit of Figure 28 demonstrates the LM2727 delivering a low output voltage at high efficiency (87%) A separate 5V supply is required to run the chip, however the input voltage can be as low as 2.2

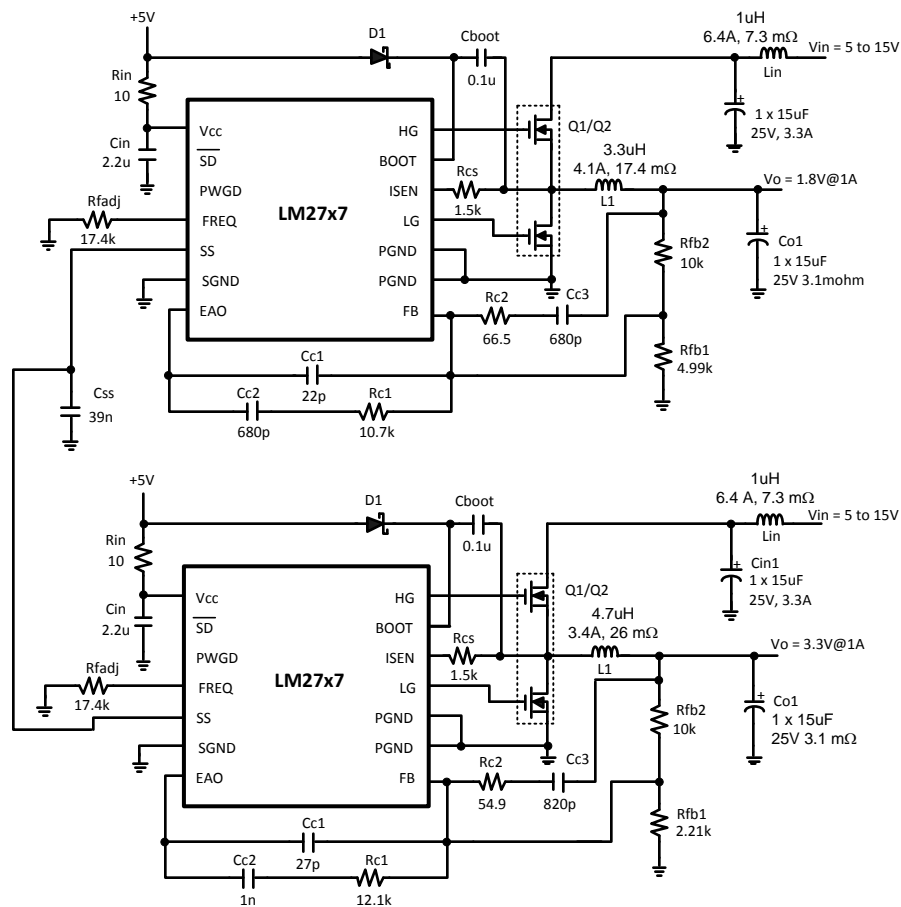

Figure 29. 1.8V and 3.3V, 1A, 1.4MHz, Simultaneous

The circuits in [Figure 29](#) are intended for ADSL applications, where the high switching frequency keeps noise out of the data transmission range. In this design, the 1.8 and 3.3V outputs come up simultaneously by using the same softstart capacitor. Because two current sources now charge the same capacitor, the capacitance must be doubled to achieve the same softstart time. (Here, 40nF is used to achieve a 5ms softstart time.) A common softstart capacitor means that, should one circuit enter current limit, the other circuit will also enter current limit. In addition, if both circuits are built with the LM2727, a UVP or OVP fault on one circuit will cause both circuits to latch off. The additional compensation components Rc2 and Cc3 are needed for the low ESR, all ceramic output capacitors, and the wide (3x) range of Vin.

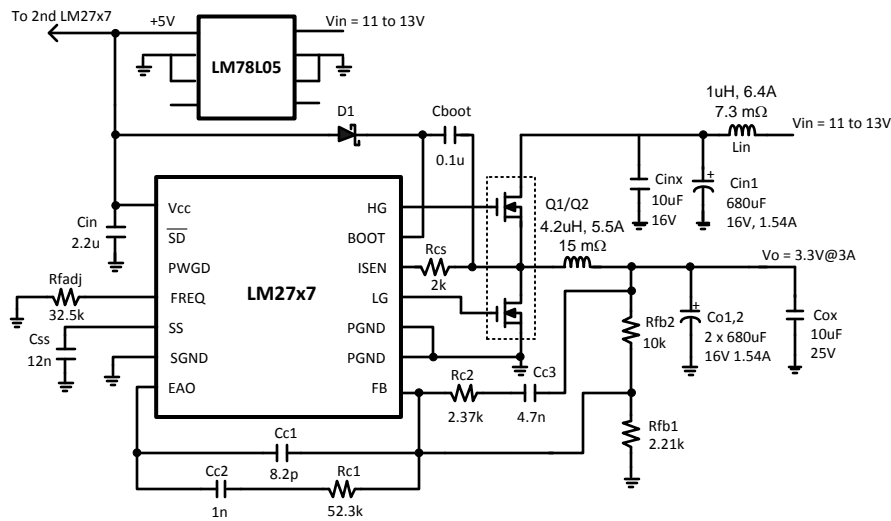

Figure 30. 12V Unregulated to 3.3V, 3A, 750kHz

This circuit shows the LM27x7 paired with a cost effective solution to provide the 5V chip power supply, using no extra components other than the LM78L05 regulator itself. The input voltage comes from a 'brick' power supply which does not regulate the 12V line tightly. Additional, inexpensive 10uF ceramic capacitors (Cinx and Cox) help isolate devices with sensitive databands, such as DSL and cable modems, from switching noise and harmonics.

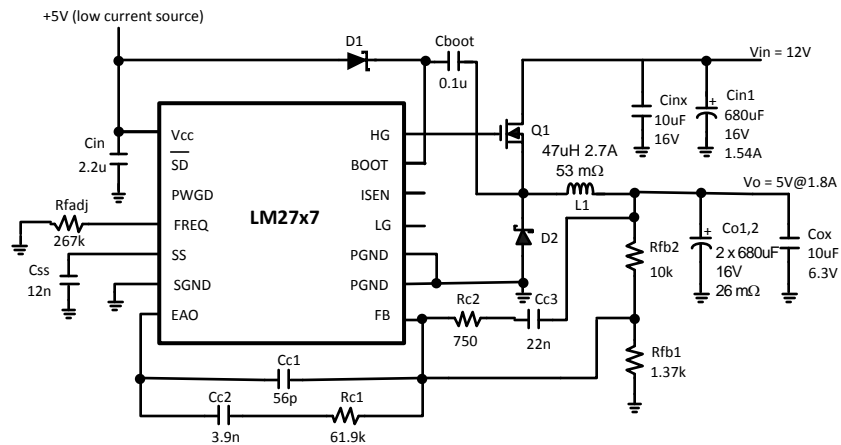

Figure 31. 12V to 5V, 1.8A, 100kHz

In situations where low cost is very important, the LM27x7 can also be used as an asynchronous controller, as shown in the above circuit. Although a schottky diode in place of the bottom FET will not be as efficient, it will cost much less than the FET. The 5V at low current needed to run the LM27x7 could come from a zener diode or inexpensive regulator, such as the one shown in Figure 30. Because the LM27x7 senses current in the low side MOSFET, the current limit feature will not function in an asynchronous design. The ISEN pin should be left open in this case.

Table 1. Bill of Materials for Typical Application Circuit

ID	Part Number	Type	Size	Parameters	Qty.	Vendor
U1	LM2727	Synchronous Controller	TSSOP-14	TSSOP-14	1	Texas Instruments
Q1, Q2	Si4884DY	N-MOSFET	SO-8	30V, 4.1mΩ, 36nC	1	Vishay
L1	RLF7030T-1R5N6R1	Inductor	7.1x7.1x3.2mm	1.5μH, 6.1A 9.6mΩ	1	TDK
Cin1, Cin2	C2012X5R1J106M	MLCC	0805	10μF 6.3V	2	TDK
Cinx	C3216X7R1E105K	Capacitor	1206	1μF, 25V	1	TDK
Co1, Co2	6MV2200WG	AL-E	10mm D 20mm H	2200μF 6.3V125mΩ	2	Sanyo
Cboot	VJ1206X104XXA	Capacitor	1206	0.1μF, 25V	1	Vishay
Cin	C3216X7R1E225K	Capacitor	1206	0.1μF, 25V	1	TDK
Css	VJ1206X123KXX	Capacitor	1206	12nF, 25V	1	Vishay
Cc1	VJ1206A2R2KXX	Capacitor	1206	2.2pF 10%	1	Vishay
Cc2	VJ1206A181KXX	Capacitor	1206	180pF 10%	1	Vishay
Rin	CRCW1206100J	Resistor	1206	10Ω 5%	1	Vishay
Rfadj	CRCW12066342F	Resistor	1206	63.4kΩ 1%	1	Vishay
Rc1	CRCW12063923F	Resistor	1206	392kΩ 1%	1	Vishay
Rfb1	CRCW12061002F	Resistor	1206	10kΩ 1%	1	Vishay
Rfb2	CRCW12061002F	Resistor	1206	10kΩ 1%	1	Vishay
Rcs	CRCW1206222J	Resistor	1206	2.2kΩ 5%	1	Vishay

**Table 2. Bill of Materials for Circuit of Figure 25
(Identical to BOM for 1.5V except as noted below)**

ID	Part Number	Type	Size	Parameters	Qty.	Vendor
L1	RLF12560T-2R7N110	Inductor	12.5x12.8x6mm	2.7μH, 14.4A 4.5mΩ	1	TDK
Co1, Co2, Co3, Co4	10TPB100M	POSCAP	7.3x4.3x2.8mm	100μF 10V 1.9Arms	4	Sanyo
Cc1	VJ1206A6R8KXX	Capacitor	1206	6.8pF 10%	1	Vishay
Cc2	VJ1206A271KXX	Capacitor	1206	270pF 10%	1	Vishay
Cc3	VJ1206A471KXX	Capacitor	1206	470pF 10%	1	Vishay
Rc2	CRCW12068451F	Resistor	1206	8.45kΩ 1%	1	Vishay
Rfb1	CRCW12061102F	Resistor	1206	11kΩ 1%	1	Vishay

Table 3. Bill of Materials for Circuit of Figure 26

ID	Part Number	Type	Size	Parameters	Qty.	Vendor
U1	LM2727	Synchronous Controller	TSSOP-14		1	Texas Instruments
Q1	Si4442DY	N-MOSFET	SO-8	30V, 4.1mΩ, @ 4.5V, 36nC	1	Vishay
Q2	Si4442DY	N-MOSFET	SO-8	30V, 4.1mΩ, @ 4.5V, 36nC	1	Vishay
D1	BAT-54	Schottky Diode	SOT-23	30V	1	Vishay
Lin	SLF12575T-1R2N8R2	Inductor	12.5x12.5x7.5mm	12μH, 8.2A, 6.9mΩ	1	Coilcraft
L1	D05022-152HC	Inductor	22.35x16.26x8mm	1.5μH, 15A, 4mΩ	1	Coilcraft
Cin1, Cin2	10MV5600AX	Aluminum Electrolytic	16mm D 25mm H	5600μF10V 2.35Arms	2	Sanyo
Cinx	C3216X7R1E105K	Capacitor	1206	1μF, 25V	1	TDK
Co1, Co2, Co3	10MV5600AX	Aluminum Electrolytic	16mm D 25mm H	5600μF10V 2.35Arms	2	Sanyo
Cboot	VJ1206X104XXA	Capacitor	1206	0.1μF, 25V	1	Vishay
Cin	C3216X7R1E225K	Capacitor	1206	2.2μF, 25V	1	TDK
Css	VJ1206X123KXX	Capacitor	1206	12nF, 25V	1	Vishay
Cc1	VJ1206A4R7KXX	Capacitor	1206	4.7pF 10%	1	Vishay

Table 3. Bill of Materials for Circuit of Figure 26 (continued)

ID	Part Number	Type	Size	Parameters	Qty.	Vendor
Cc2	VJ1206A102KXX	Capacitor	1206	1nF 10%	1	Vishay
Rin	CRCW1206100J	Resistor	1206	10Ω 5%	1	Vishay
Rfadj	CRCW12068872F	Resistor	1206	88.7kΩ 1%	1	Vishay
Rc1	CRCW12062293F	Resistor	1206	229kΩ 1%	1	Vishay
Rfb1	CRCW12064991F	Resistor	1206	4.99kΩ 1%	1	Vishay
Rfb2	CRCW12064991F	Resistor	1206	4.99kΩ 1%	1	Vishay
Rcs	CRCW1206152J	Resistor	1206	1.5kΩ 5%	1	Vishay

Table 4. Bill of Materials for Circuit of Figure 27

ID	Part Number	Type	Size	Parameters	Qty.	Vendor
U1	LM2727	Synchronous Controller	TSSOP-14		1	Texas Instruments
Q1/Q2	Si4826DY	Asymmetric Dual N-MOSFET	SO-8	30V, 24mΩ/ 8nC Top 16.5mΩ/ 15nC	1	Vishay
L1	DO3316P-222	Inductor	12.95x9.4x 5.21mm	2.2μH, 6.1A, 12mΩ	1	Coilcraft
Cin1	10TPB100ML	POSCAP	7.3x4.3x3.1mm	100μF 10V 1.9Arms	1	Sanyo
Co1	4TPB220ML	POSCAP	7.3x4.3x3.1mm	220μF 4V 1.9Arms	1	Sanyo
Cc	C3216X7R1E105K	Capacitor	1206	1μF, 25V	1	TDK
Cin	C3216X7R1E225K	Capacitor	1206	2.2μF, 25V	1	TDK
Css	VJ1206X123KXX	Capacitor	1206	12nF, 25V	1	Vishay
Cc1	VJ1206A100KXX	Capacitor	1206	10pF 10%	1	Vishay
Cc2	VJ1206A561KXX	Capacitor	1206	560pF 10%	1	Vishay
Rin	CRCW1206100J	Resistor	1206	10Ω 5%	1	Vishay
Rfadj	CRCW12064222F	Resistor	1206	42.2kΩ 1%	1	Vishay
Rc1	CRCW12065112F	Resistor	1206	51.1kΩ 1%	1	Vishay
Rfb1	CRCW12062491F	Resistor	1206	2.49kΩ 1%	1	Vishay
Rfb2	CRCW12064991F	Resistor	1206	4.99kΩ 1%	1	Vishay
Rcs	CRCW1206272J	Resistor	1206	2.7kΩ 5%	1	Vishay

Table 5. Bill of Materials for Circuit of Figure 28

ID	Part Number	Type	Size	Parameters	Qty.	Vendor
U1	LM2727	Synchronous Controller	TSSOP-14		1	Texas Instruments
Q1	Si4884DY	N-MOSFET	SO-8	30V, 13.5mΩ, @ 4.5V 15.3nC	1	Vishay
Q2	Si4884DY	N-MOSFET	SO-8	30V, 13.5mΩ, @ 4.5V 15.3nC	1	Vishay
D1	BAT-54	Schottky Diode	SOT-23	30V	1	Vishay
Lin	P1166.102T	Inductor	7.29x7.29 3.51mm	1μH, 11A 3.7mΩ	1	Pulse
L1	P1168.102T	Inductor	12x12x4.5 mm	1μH, 11A, 3.7mΩ	1	Pulse
Cin1	10MV5600AX	Aluminum Electrolytic	16mm D 25mm H	5600μF 10V 2.35Arms	1	Sanyo
Cinx	C3216X7R1E105K	Capacitor	1206	1μF, 25V	1	TDK
Co1, Co2, Co3	16MV4700WX	Aluminum Electrolytic	12.5mm D 30mm H	4700μF 16V 2.8Arms	2	Sanyo
Cboot	VJ1206X104XXA	Capacitor	1206	0.1μF, 25V	1	Vishay
Cin	C3216X7R1E225K	Capacitor	1206	2.2μF, 25V	1	TDK
Css	VJ1206X123KXX	Capacitor	1206	12nF, 25V	1	Vishay
Cc1	VJ1206A4R7KXX	Capacitor	1206	4.7pF 10%	1	Vishay

Table 5. Bill of Materials for Circuit of Figure 28 (continued)

ID	Part Number	Type	Size	Parameters	Qty.	Vendor
Cc2	VJ1206A681KXX	Capacitor	1206	680pF 10%	1	Vishay
Rin	CRCW1206100J	Resistor	1206	10Ω 5%	1	Vishay
Rfadj	CRCW12064992F	Resistor	1206	49.9kΩ 1%	1	Vishay
Rc1	CRCW12061473F	Resistor	1206	147kΩ 1%	1	Vishay
Rfb1	CRCW12061492F	Resistor	1206	14.9kΩ 1%	1	Vishay
Rfb2	CRCW12064991F	Resistor	1206	4.99kΩ 1%	1	Vishay
Rcs	CRCW1206332J	Resistor	1206	3.3kΩ 5%	1	Vishay

Table 6. Bill of Materials for Circuit of Figure 29

ID	Part Number	Type	Size	Parameters	Qty.	Vendor
U1	LM2727	Synchronous Controller	TSSOP-14		1	Texas Instruments
Q1/Q2	Si4826DY	Assymetric Dual N-MOSFET	SO-8	30V, 24mΩ/ 8nC Top 16.5mΩ/ 15nC	1	Vishay
D1	BAT-54	Schottky Diode	SOT-23	30V	1	Vishay
Lin	RLF7030T-1R0N64	Inductor	6.8x7.1x3.2mm	1μH, 6.4A, 7.3mΩ	1	TDK
L1	RLF7030T-3R3M4R1	Inductor	6.8x7.1x3.2mm	3.3μH, 4.1A, 17.4mΩ	1	TDK
Cin1	C4532X5R1E156M	MLCC	1812	15μF 25V 3.3Arms	1	Sanyo
Co1	C4532X5R1E156M	MLCC	1812	15μF 25V 3.3Arms	1	Sanyo
Cboot	VJ1206X104XXA	Capacitor	1206	0.1μF, 25V	1	TDK
Cin	C3216X7R1E225K	Capacitor	1206	2.2μF, 25V	1	TDK
Css	VJ1206X393KXX	Capacitor	1206	39nF, 25V	1	Vishay
Cc1	VJ1206A220KXX	Capacitor	1206	22pF 10%	1	Vishay
Cc2	VJ1206A681KXX	Capacitor	1206	680pF 10%	1	Vishay
Cc3	VJ1206A681KXX	Capacitor	1206	680pF 10%	1	Vishay
Rin	CRCW1206100J	Resistor	1206	10Ω 5%	1	Vishay
Rfadj	CRCW12061742F	Resistor	1206	17.4kΩ 1%	1	Vishay
Rc1	CRCW12061072F	Resistor	1206	10.7kΩ 1%	1	Vishay
Rc2	CRCW120666R5F	Resistor	1206	66.5Ω 1%	1	Vishay
Rfb1	CRCW12064991F	Resistor	1206	4.99kΩ 1%	1	Vishay
Rfb2	CRCW12061002F	Resistor	1206	10kΩ 1%	1	Vishay
Rcs	CRCW1206152J	Resistor	1206	1.5kΩ 5%	1	Vishay

**Table 7. Bill of Materials for 3.3V Circuit of Figure 29
(Identical to BOM for 1.8V except as noted below)**

ID	Part Number	Type	Size	Parameters	Qty.	Vendor
L1	RLF7030T-4R7M3R4	Inductor	6.8x7.1x 3.2mm	4.7μH, 3.4A, 26mΩ	1	TDK
Cc1	VJ1206A270KXX	Capacitor	1206	27pF 10%	1	Vishay
Cc2	VJ1206X102KXX	Capacitor	1206	1nF 10%	1	Vishay
Cc3	VJ1206A821KXX	Capacitor	1206	820pF 10%	1	Vishay
Rc1	CRCW12061212F	Resistor	1206	12.1kΩ 1%	1	Vishay
Rc2	CRCW12054R9F	Resistor	1206	54.9Ω 1%	1	Vishay
Rfb1	CRCW12062211F	Resistor	1206	2.21kΩ 1%	1	Vishay
Rfb2	CRCW12061002F	Resistor	1206	10kΩ 1%	1	Vishay

Table 8. Bill of Materials for Circuit of Figure 30

ID	Part Number	Type	Size	Parameters	Qty.	Vendor
U1	LM2727	Synchronous Controller	TSSOP-14		1	Texas Instruments
U2	LM78L05	Voltage Regulator	SO-8		1	Texas Instruments
Q1/Q2	Si4826DY	Assymetric Dual N-MOSFET	SO-8	30V, 24mΩ/ 8nC Top 16.5mΩ/ 15nC	1	Vishay
D1	BAT-54	Schottky Diode	SOT-23	30V	1	Vishay
Lin	RLF7030T-1R0N64	Inductor	6.8x7.1x3.2mm	1μH, 6.4A, 7.3mΩ	1	TDK
L1	SLF12565T-4R2N5R5	Inductor	12.5x12.5x6.5mm	4.2μH, 5.5A, 15mΩ	1	TDK
Cin1	16MV680WG	Al-E	D: 10mm L: 12.5mm	680μF 16V 3.4Arms	1	Sanyo
Cinx	C3216X5R1C106M	MLCC	1210	10μF 16V 3.4Arms	1	TDK
Co1 Co2	16MV680WG	MLCC	1812	15μF 25V 3.3Arms	1	Sanyo
Cox	C3216X5R10J06M	MLCC	1206	10μF 6.3V 2.7A		TDK
Cboot	VJ1206X104XXA	Capacitor	1206	0.1μF, 25V	1	Vishay
Cin	C3216X7R1E225K	Capacitor	1206	2.2μF, 25V	1	TDK
Css	VJ1206X123KXX	Capacitor	1206	12nF, 25V	1	Vishay
Cc1	VJ1206A8R2KXX	Capacitor	1206	8.2pF 10%	1	Vishay
Cc2	VJ1206X102KXX	Capacitor	1206	1nF 10%	1	Vishay
Cc3	VJ1206X472KXX	Capacitor	1206	4.7nF 10%	1	Vishay
Rfadj	CRCW12063252F	Resistor	1206	32.5kΩ 1%	1	Vishay
Rc1	CRCW12065232F	Resistor	1206	52.3kΩ 1%	1	Vishay
Rc2	CRCW120662371F	Resistor	1206	2.37Ω 1%	1	Vishay
Rfb1	CRCW12062211F	Resistor	1206	2.21kΩ 1%	1	Vishay
Rfb2	CRCW12061002F	Resistor	1206	10kΩ 1%	1	Vishay
Rcs	CRCW1206202J	Resistor	1206	2kΩ 5%	1	Vishay

Table 9. Bill of Materials for Circuit of Figure 31

ID	Part Number	Type	Size	Parameters	Qty.	Vendor
U1	LM2727	Synchronous Controller	TSSOP-14		1	Texas Instruments
Q1	Si4894DY	N-MOSFET	SO-8	30V, 15mΩ, 11.5nC	1	Vishay
D2	MBRS330T3	Schottky Diode	SO-8	30V, 3A	1	ON
L1	SLF12565T-470M2R4	Inductor	12.5x12.8x 4.7mm	47μH, 2.7A 53mΩ	1	TDK
D1	MBR0520	Schottky Diode	1812	20V 0.5A	1	ON
Cin1	16MV680WG	Al-E	1206	680μF, 16V, 1.54Arms	1	Sanyo
Cinx	C3216X5R1C106M	MLCC	1206	10μF, 16V, 3.4Arms	1	TDK
Co1, Co2	16MV680WG	Al-E	D: 10mm L: 12.5mm	680μF 16V 26mΩ	2	Sanyo
Cox	C3216X5R10J06M	MLCC	1206	10μF, 6.3V 2.7A	1	TDK
Cboot	VJ1206X104XXA	Capacitor	1206	0.1μF, 25V	1	Vishay
Cin	C3216X7R1E225K	Capacitor	1206	2.2μF, 25V	1	TDK
Css	VJ1206X123KXX	Capacitor	1206	12nF, 25V	1	Vishay
Cc1	VJ1206A561KXX	Capacitor	1206	56pF 10%	1	Vishay
Cc2	VJ1206X392KXX	Capacitor	1206	3.9nF 10%	1	Vishay
Cc3	VJ1206X223KXX	Capacitor	1206	22nF 10%	1	Vishay
Rfadj	CRCW12062673F	Resistor	1206	267kΩ 1%	1	Vishay
Rc1	CRCW12066192F	Resistor	1206	61.9kΩ 1%	1	Vishay
Rc2	CRCW12067503F	Resistor	1206	750kΩ 1%	1	Vishay

Table 9. Bill of Materials for Circuit of [Figure 31](#) (continued)

ID	Part Number	Type	Size	Parameters	Qty.	Vendor
Rfb1	CRCW12061371F	Resistor	1206	1.37k Ω 1%	1	Vishay
Rfb2	CRCW12061002F	Resistor	1206	10k Ω 1%	1	Vishay
Rcs	CRCW1206122F	Resistor	1206	1.2k Ω 5%	1	Vishay

REVISION HISTORY

Changes from Revision C (March 2013) to Revision D	Page
<hr/> <ul style="list-style-type: none">• Changed layout of National Data Sheet to TI format	23

PACKAGING INFORMATION

Orderable Device	Status (1)	Package Type	Package Drawing	Pins	Package Qty	Eco Plan (2)	Lead/Ball Finish (6)	MSL Peak Temp (3)	Op Temp (°C)	Device Marking (4/5)	Samples
LM2727MTC/NOPB	ACTIVE	TSSOP	PW	14	94	Green (RoHS & no Sb/Br)	CU NIPDAU CU SN	Level-1-260C-UNLIM	0 to 125	2727 MTC	Samples
LM2727MTCX/NOPB	ACTIVE	TSSOP	PW	14	2500	Green (RoHS & no Sb/Br)	CU NIPDAU CU SN	Level-1-260C-UNLIM	0 to 125	2727 MTC	Samples
LM2737MTC/NOPB	ACTIVE	TSSOP	PW	14	94	Green (RoHS & no Sb/Br)	CU NIPDAU CU SN	Level-1-260C-UNLIM	-40 to 125	2737 MTC	Samples
LM2737MTCX/NOPB	ACTIVE	TSSOP	PW	14	2500	Green (RoHS & no Sb/Br)	CU NIPDAU CU SN	Level-1-260C-UNLIM	-40 to 125	2737 MTC	Samples

(1) The marketing status values are defined as follows:

ACTIVE: Product device recommended for new designs.

LIFEBUY: TI has announced that the device will be discontinued, and a lifetime-buy period is in effect.

NRND: Not recommended for new designs. Device is in production to support existing customers, but TI does not recommend using this part in a new design.

PREVIEW: Device has been announced but is not in production. Samples may or may not be available.

OBSOLETE: TI has discontinued the production of the device.

(2) **RoHS:** TI defines "RoHS" to mean semiconductor products that are compliant with the current EU RoHS requirements for all 10 RoHS substances, including the requirement that RoHS substance do not exceed 0.1% by weight in homogeneous materials. Where designed to be soldered at high temperatures, "RoHS" products are suitable for use in specified lead-free processes. TI may reference these types of products as "Pb-Free".

RoHS Exempt: TI defines "RoHS Exempt" to mean products that contain lead but are compliant with EU RoHS pursuant to a specific EU RoHS exemption.

Green: TI defines "Green" to mean the content of Chlorine (Cl) and Bromine (Br) based flame retardants meet JS709B low halogen requirements of <=1000ppm threshold. Antimony trioxide based flame retardants must also meet the <=1000ppm threshold requirement.

(3) MSL, Peak Temp. - The Moisture Sensitivity Level rating according to the JEDEC industry standard classifications, and peak solder temperature.

(4) There may be additional marking, which relates to the logo, the lot trace code information, or the environmental category on the device.

(5) Multiple Device Markings will be inside parentheses. Only one Device Marking contained in parentheses and separated by a "-" will appear on a device. If a line is indented then it is a continuation of the previous line and the two combined represent the entire Device Marking for that device.

(6) Lead/Ball Finish - Orderable Devices may have multiple material finish options. Finish options are separated by a vertical ruled line. Lead/Ball Finish values may wrap to two lines if the finish value exceeds the maximum column width.

Important Information and Disclaimer: The information provided on this page represents TI's knowledge and belief as of the date that it is provided. TI bases its knowledge and belief on information provided by third parties, and makes no representation or warranty as to the accuracy of such information. Efforts are underway to better integrate information from third parties. TI has taken and

continues to take reasonable steps to provide representative and accurate information but may not have conducted destructive testing or chemical analysis on incoming materials and chemicals. TI and TI suppliers consider certain information to be proprietary, and thus CAS numbers and other limited information may not be available for release.

In no event shall TI's liability arising out of such information exceed the total purchase price of the TI part(s) at issue in this document sold by TI to Customer on an annual basis.

TAPE AND REEL INFORMATION



QUADRANT ASSIGNMENTS FOR PIN 1 ORIENTATION IN TAPE



*All dimensions are nominal

Device	Package Type	Package Drawing	Pins	SPQ	Reel Diameter (mm)	Reel Width W1 (mm)	A0 (mm)	B0 (mm)	K0 (mm)	P1 (mm)	W (mm)	Pin1 Quadrant
LM2727MTCX/NOPB	TSSOP	PW	14	2500	330.0	12.4	6.95	5.6	1.6	8.0	12.0	Q1
LM2737MTCX/NOPB	TSSOP	PW	14	2500	330.0	12.4	6.95	5.6	1.6	8.0	12.0	Q1

TAPE AND REEL BOX DIMENSIONS

*All dimensions are nominal

Device	Package Type	Package Drawing	Pins	SPQ	Length (mm)	Width (mm)	Height (mm)
LM2727MTCX/NOPB	TSSOP	PW	14	2500	367.0	367.0	35.0
LM2737MTCX/NOPB	TSSOP	PW	14	2500	367.0	367.0	35.0

PW (R-PDSO-G14)

PLASTIC SMALL OUTLINE



- NOTES:
- All linear dimensions are in millimeters.
 - This drawing is subject to change without notice.
 - Publication IPC-7351 is recommended for alternate designs.
 - Laser cutting apertures with trapezoidal walls and also rounding corners will offer better paste release. Customers should contact their board assembly site for stencil design recommendations. Refer to IPC-7525 for other stencil recommendations.
 - Customers should contact their board fabrication site for solder mask tolerances between and around signal pads.

IMPORTANT NOTICE AND DISCLAIMER

TI PROVIDES TECHNICAL AND RELIABILITY DATA (INCLUDING DATASHEETS), DESIGN RESOURCES (INCLUDING REFERENCE DESIGNS), APPLICATION OR OTHER DESIGN ADVICE, WEB TOOLS, SAFETY INFORMATION, AND OTHER RESOURCES "AS IS" AND WITH ALL FAULTS, AND DISCLAIMS ALL WARRANTIES, EXPRESS AND IMPLIED, INCLUDING WITHOUT LIMITATION ANY IMPLIED WARRANTIES OF MERCHANTABILITY, FITNESS FOR A PARTICULAR PURPOSE OR NON-INFRINGEMENT OF THIRD PARTY INTELLECTUAL PROPERTY RIGHTS.

These resources are intended for skilled developers designing with TI products. You are solely responsible for (1) selecting the appropriate TI products for your application, (2) designing, validating and testing your application, and (3) ensuring your application meets applicable standards, and any other safety, security, or other requirements. These resources are subject to change without notice. TI grants you permission to use these resources only for development of an application that uses the TI products described in the resource. Other reproduction and display of these resources is prohibited. No license is granted to any other TI intellectual property right or to any third party intellectual property right. TI disclaims responsibility for, and you will fully indemnify TI and its representatives against, any claims, damages, costs, losses, and liabilities arising out of your use of these resources.

TI's products are provided subject to TI's Terms of Sale (www.ti.com/legal/termsofsale.html) or other applicable terms available either on ti.com or provided in conjunction with such TI products. TI's provision of these resources does not expand or otherwise alter TI's applicable warranties or warranty disclaimers for TI products.

Mailing Address: Texas Instruments, Post Office Box 655303, Dallas, Texas 75265
Copyright © 2018, Texas Instruments Incorporated

Looking for pricing, stock, or lifecycle information?

Click below to explore more details on WIN SOURCE:

 [View LM2727MTCX/NOPB on WIN SOURCE](#)

 [Texas Instruments](#) Information

Optimize Your Supply Chain with WIN SOURCE Solutions

-  Global Sourcing Solution
-  Obsolete Management
-  Cost Control Management
-  Shortage Management
-  Alternative Solution
-  Excess Inventory Management