



**THE DATASHEET OF
LM2734XMK/NOPB**



LM2734 Thin SOT 1-A Load Step-Down DC-DC Regulator

1 Features

- Thin SOT-6 Package
- 3.0-V to 20-V Input Voltage Range
- 0.8-V to 18-V Output Voltage Range
- 1-A Output Current
- 550-kHz (LM2734Y) and 1.6-MHz (LM2734X) Switching Frequencies
- 300-mΩ NMOS Switch
- 30-nA Shutdown Current
- 0.8-V, 2% Internal Voltage Reference
- Internal Soft-Start
- Current-Mode, PWM Operation
- WEBENCH® Online Design Tool
- Thermal Shutdown
- LM2734XQ and LM2734YQ are AEC-Q100 Grade 1 Qualified and are Manufactured on an Automotive Grade Flow.

2 Applications

- Local Point-of-Load Regulation
- Core Power in HDDs
- Set-Top Boxes
- Battery-Powered Devices
- USB Powered Devices
- DSL Modems
- Notebook Computers
- Automotive

3 Description

The LM2734 regulator is a monolithic, high-frequency, PWM step-down DC-DC converter in a 6-pin Thin SOT package. The device provides all the active functions to provide local DC-DC conversion with fast transient response and accurate regulation in the smallest possible PCB area.

With a minimum of external components and online design support through WEBENCH, the LM2734 regulator is easy to use. The ability to drive 1-A loads with an internal 300-mΩ NMOS switch using state-of-the-art 0.5-μm BiCMOS technology results in the best power density available. The world-class control circuitry allows for on-times as low as 13 ns, thus supporting exceptionally high-frequency conversion over the entire 3-V to 20-V input operating range down to the minimum output voltage of 0.8 V. Switching frequency is internally set to 550 kHz (LM2734Y) or 1.6 MHz (LM2734X), allowing the use of extremely small surface-mount inductors and chip capacitors. Even though the operating frequencies are very high, efficiencies up to 90% are easy to achieve. External shutdown is included, featuring an ultra-low standby current of 30 nA.

The LM2734 regulator uses current-mode control and internal compensation to provide high-performance regulation over a wide range of operating conditions. Additional features include internal soft-start circuitry to reduce inrush current, pulse-by-pulse current limit, thermal shutdown, and output overvoltage protection.

Device Information⁽¹⁾

PART NUMBER	PACKAGE	BODY SIZE (NOM)
LM2734	SOT (6)	2.90 mm x 1.60 mm

(1) For all available packages, see the orderable addendum at the end of the datasheet.

Typical Application Circuit

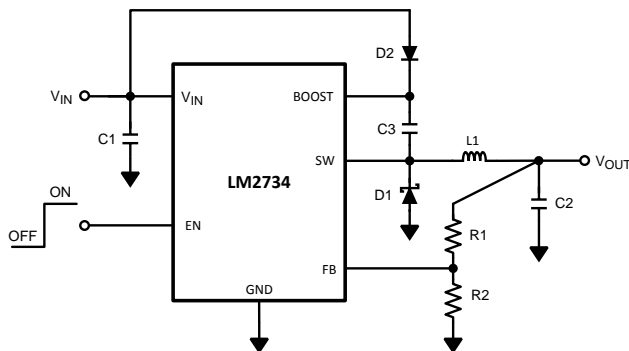

Efficiency vs Load Current

$$V_{IN} = 5 \text{ V}, V_{OUT} = 3.3 \text{ V}$$

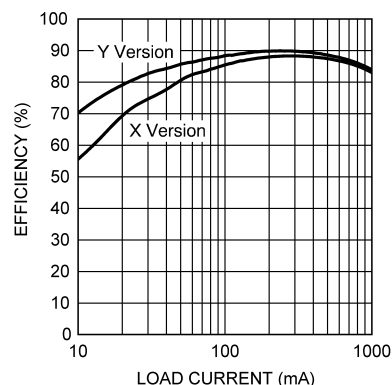

Table of Contents

1 Features	1	7.3 Feature Description	9
2 Applications	1	7.4 Device Functional Modes	10
3 Description	1	8 Application and Implementation	11
4 Revision History	2	8.1 Application Information	11
5 Pin Configuration and Functions	3	8.2 Typical Applications	14
6 Specifications	4	9 Power Supply Recommendations	28
6.1 Absolute Maximum Ratings	4	10 Layout	28
6.2 ESD Ratings	4	10.1 Layout Guidelines	28
6.3 Recommended Operating Conditions	4	10.2 Layout Example	29
6.4 Thermal Information	4	11 Device and Documentation Support	30
6.5 Electrical Characteristics	5	11.1 Third-Party Products Disclaimer	30
6.6 Typical Performance Characteristics	6	11.2 Trademarks	30
7 Detailed Description	8	11.3 Electrostatic Discharge Caution	30
7.1 Overview	8	11.4 Glossary	30
7.2 Functional Block Diagram	9	12 Mechanical, Packaging, and Orderable Information	30

4 Revision History

Changes from Revision I (April 2013) to Revision J

Page

- Added *ESD Ratings* table, *Feature Description* section, *Device Functional Modes*, *Application and Implementation* section, *Power Supply Recommendations* section, *Layout* section, *Device and Documentation Support* section, and *Mechanical, Packaging, and Orderable Information* section. **1**

5 Pin Configuration and Functions

See Package Number DDC (R-PDSO-G6)
6-Lead SOT
Top View

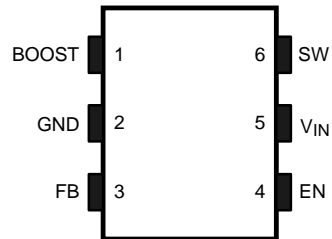

Pin Functions

PIN		I/O	DESCRIPTION
NAME	NO.		
BOOST	1	I	Boost voltage that drives the internal NMOS control switch. A bootstrap capacitor is connected between the BOOST and SW pins.
GND	2	GND	Signal and Power ground pin. Place the bottom resistor of the feedback network as close as possible to this pin for accurate regulation.
FB	3	I	Feedback pin. Connect FB to the external resistor divider to set output voltage.
EN	4	I	Enable control input. Logic high enables operation. Do not allow this pin to float or be greater than $V_{IN} + 0.3\text{ V}$.
V_{IN}	5	I	Input supply voltage. Connect a bypass capacitor to this pin.
SW	6	O	Output switch. Connects to the inductor, catch diode, and bootstrap capacitor.

6 Specifications

6.1 Absolute Maximum Ratings

 over operating free-air temperature (unless otherwise noted)⁽¹⁾⁽²⁾

	MIN	MAX	UNIT
V _{IN}	-0.5	24	V
SW Voltage	-0.5	24	V
Boost Voltage	-0.5	30	V
Boost to SW Voltage	-0.5	6.0	V
FB Voltage	-0.5	0.3	V
EN Voltage	-0.5	V _{IN} + 0.3	V
Junction Temperature		150	°C
Soldering Information Reflow Peak Pkg. Temp.(15s)		260	°C
T _{stg} Storage temperature	-65	150	°C

- (1) Stresses beyond those listed under *Absolute Maximum Ratings* may cause permanent damage to the device. These are stress ratings only, which do not imply functional operation of the device at these or any other conditions beyond those indicated under *Recommended Operating Conditions*. Exposure to absolute-maximum-rated conditions for extended periods may affect device reliability.
- (2) If Military/Aerospace specified devices are required, please contact the Texas Instruments Sales Office/ Distributors for availability and specifications.

6.2 ESD Ratings

	VALUE	UNIT
V _{ESD} Electrostatic discharge	Human Body Model (HBM), per ANSI/ESDA/JEDEC JS001 ⁽¹⁾	±2000 V

- (1) JEDEC document JEP155 states that 500-V HBM allows safe manufacturing with a standard ESD control process.

6.3 Recommended Operating Conditions

over operating free-air temperature range (unless otherwise noted)

	MIN	NOM	MAX	UNIT
V _{IN}	3		20	V
SW Voltage	-0.5		20	V
Boost Voltage	-0.5		25	V
Boost to SW Voltage	1.6		5.5	V
Junction Temperature Range	-40		125	°C

6.4 Thermal Information

THERMAL METRIC ⁽¹⁾		LM2734	UNIT
		DDC	
		6 PINS	
R _{θJA}	Junction-to-ambient thermal resistance	158.1	°C/W
R _{θJC(top)}	Junction-to-case (top) thermal resistance	46.5	
R _{θJB}	Junction-to-board thermal resistance	29.5	
ψ _{JT}	Junction-to-top characterization parameter	0.8	
ψ _{JB}	Junction-to-board characterization parameter	29.2	
R _{θJC(bot)}	Junction-to-case (bottom) thermal resistance	n/a	

- (1) For more information about traditional and new thermal metrics, see the *IC Package Thermal Metrics* application report, [SPRA953](#).

6.5 Electrical Characteristics

$V_{IN} = 5V$, $V_{BOOST} - V_{SW} = 5V$ unless otherwise specified. Datasheet min/max specification limits are ensured by design, test, or statistical analysis.

PARAMETER	TEST CONDITIONS	$T_J = 25^\circ\text{C}$			$T_J = -40^\circ\text{C to } 125^\circ\text{C}$			UNIT
		MIN ⁽¹⁾	TYP ⁽²⁾	MAX ⁽¹⁾	MIN	TYP	MAX	
V_{FB}	Feedback Voltage		0.800		0.784	0.816	V	
$\Delta V_{FB}/\Delta V_{IN}$	Feedback Voltage Line Regulation	$V_{IN} = 3V$ to $20V$	0.01				% / V	
I_{FB}	Feedback Input Bias Current	Sink/Source	10			250	nA	
UVLO	Undervoltage Lockout	V_{IN} Rising	2.74			2.90	V	
	Undervoltage Lockout	V_{IN} Falling	2.3		2.0			
	UVLO Hysteresis		0.44		0.30	0.62		
F_{SW}	Switching Frequency	LM2734X	1.6		1.2	1.9	MHz	
		LM2734Y	0.55		0.40	0.66		
D_{MAX}	Maximum Duty Cycle	LM2734X	92		85%			
		LM2734Y	96		90%			
D_{MIN}	Minimum Duty Cycle	LM2734X	2%					
		LM2734Y	1%					
$R_{DS(ON)}$	Switch ON Resistance	$V_{BOOST} - V_{SW} = 3V$	300			600	m Ω	
I_{CL}	Switch Current Limit	$V_{BOOST} - V_{SW} = 3V$	1.7		1.2	2.5	A	
I_Q	Quiescent Current	Switching	1.5			2.5	mA	
	Quiescent Current (shutdown)	$V_{EN} = 0V$	30				nA	
I_{BOOST}	Boost Pin Current	LM2734X (50% Duty Cycle)	2.5			3.5	mA	
		LM2734Y (50% Duty Cycle)	1.0			1.8		
V_{EN_TH}	Shutdown Threshold Voltage	V_{EN} Falling				0.4	V	
	Enable Threshold Voltage	V_{EN} Rising			1.8			
I_{EN}	Enable Pin Current	Sink/Source	10				nA	
I_{SW}	Switch Leakage		40				nA	

(1) Specified to Average Outgoing Quality Level (AOQL).

(2) Typicals represent the most likely parametric norm.

6.6 Typical Performance Characteristics

All curves taken at $V_{IN} = 5\text{ V}$, $V_{BOOST} - V_{SW} = 5\text{ V}$ and $T_A = 25^\circ\text{C}$, unless specified otherwise.

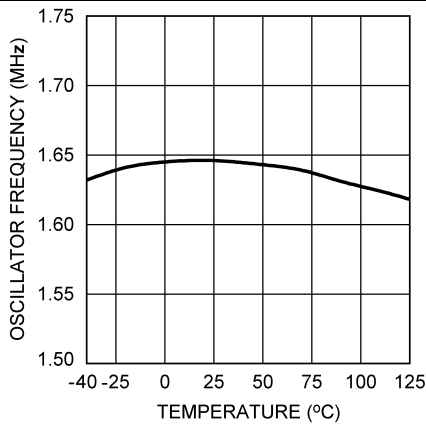

Figure 1. Oscillator Frequency vs Temperature - L1 = 4.7 μH

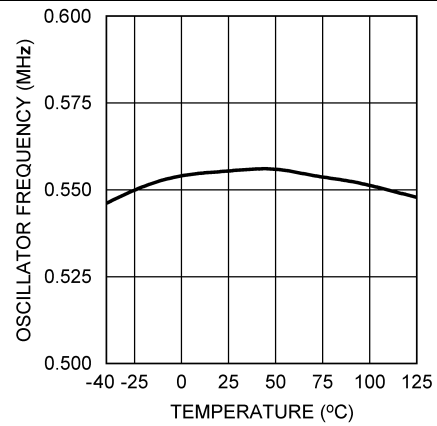

Figure 2. Oscillator Frequency vs Temperature - L1 = 10 μH

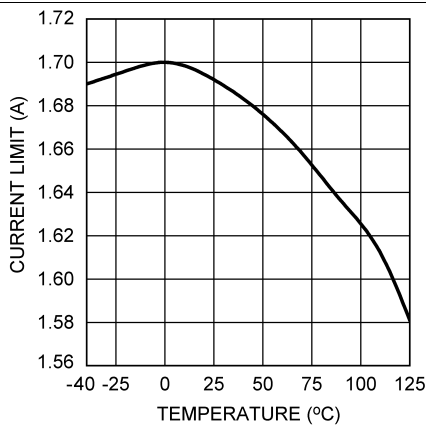

Figure 3. Current Limit vs Temperature

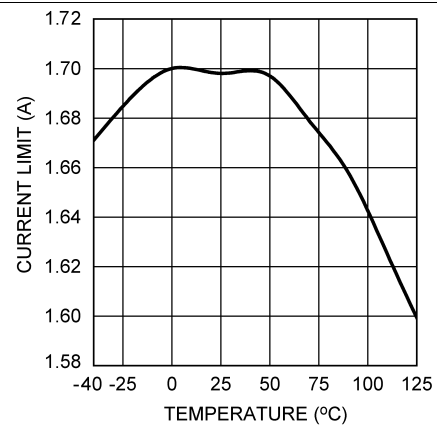

Figure 4. Current Limit vs Temperature
 $V_{IN} = 20\text{ V}$

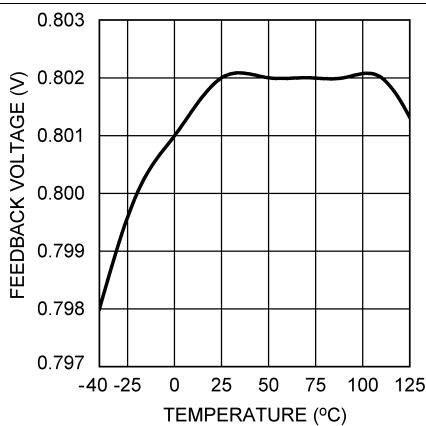

Figure 5. V_{FB} vs Temperature

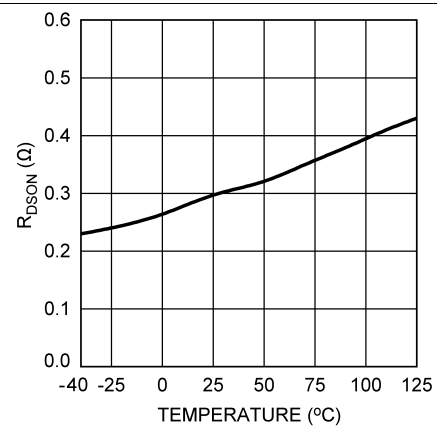

Figure 6. $R_{DS(on)}$ vs Temperature

Typical Performance Characteristics (continued)

All curves taken at $V_{IN} = 5\text{ V}$, $V_{BOOST} - V_{SW} = 5\text{ V}$ and $T_A = 25^\circ\text{C}$, unless specified otherwise.

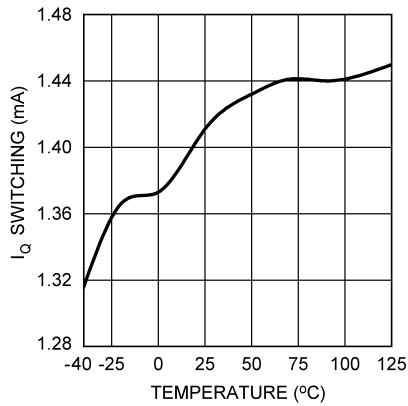

Figure 7. I_Q Switching vs Temperature

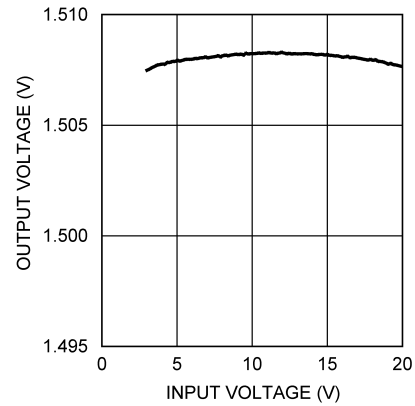

Figure 8. Line Regulation - L1 = 4.7 µH
V_{OUT} = 1.5 V, I_{OUT} = 500 mA

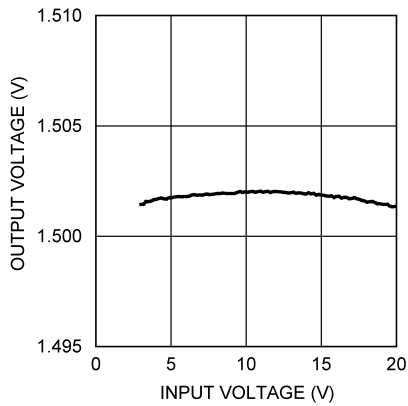

Figure 9. Line Regulation - L1 = 10 µH
V_{OUT} = 1.5 V, I_{OUT} = 500 mA

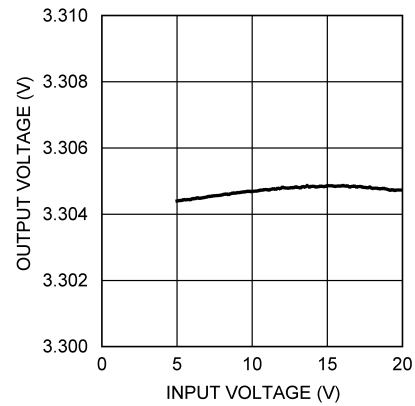

Figure 10. Line Regulation - L1 = 4.7 µH
V_{OUT} = 3.3 V, I_{OUT} = 500 mA

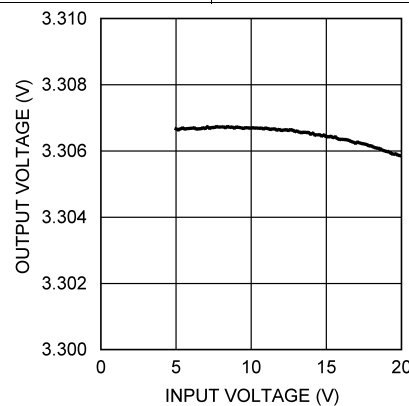

Figure 11. Line Regulation - L1 = 10 µH
V_{OUT} = 3.3 V, I_{OUT} = 500 mA

7 Detailed Description

7.1 Overview

The LM2734 device is a constant frequency PWM buck regulator IC that delivers a 1-A load current. The regulator has a preset switching frequency of either 550 kHz (LM2734Y) or 1.6 MHz (LM2734X). These high frequencies allow the LM2734 device to operate with small surface-mount capacitors and inductors, resulting in DC-DC converters that require a minimum amount of board space. The LM2734 device is internally compensated, so it is simple to use, and requires few external components. The LM2734 device uses current-mode control to regulate the output voltage.

The following operating description of the LM2734 device will refer to the Simplified Block Diagram () and to the waveforms in [Figure 12](#). The LM2734 device supplies a regulated output voltage by switching the internal NMOS control switch at constant frequency and variable duty cycle. A switching cycle begins at the falling edge of the reset pulse generated by the internal oscillator. When this pulse goes low, the output control logic turns on the internal NMOS control switch. During this on-time, the SW pin voltage (V_{SW}) swings up to approximately V_{IN} , and the inductor current (I_L) increases with a linear slope. I_L is measured by the current-sense amplifier, which generates an output proportional to the switch current. The sense signal is summed with the regulator's corrective ramp and compared to the error amplifier's output, which is proportional to the difference between the feedback voltage and V_{REF} . When the PWM comparator output goes high, the output switch turns off until the next switching cycle begins. During the switch off-time, inductor current discharges through Schottky diode D1, which forces the SW pin to swing below ground by the forward voltage (V_D) of the catch diode. The regulator loop adjusts the duty cycle (D) to maintain a constant output voltage.

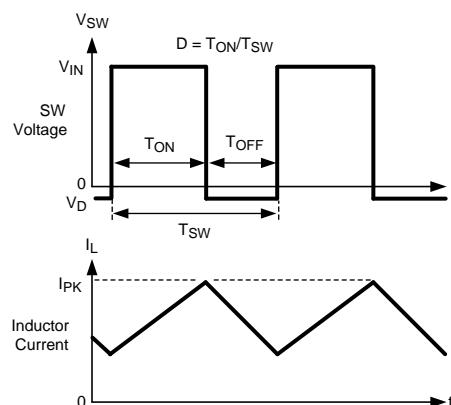
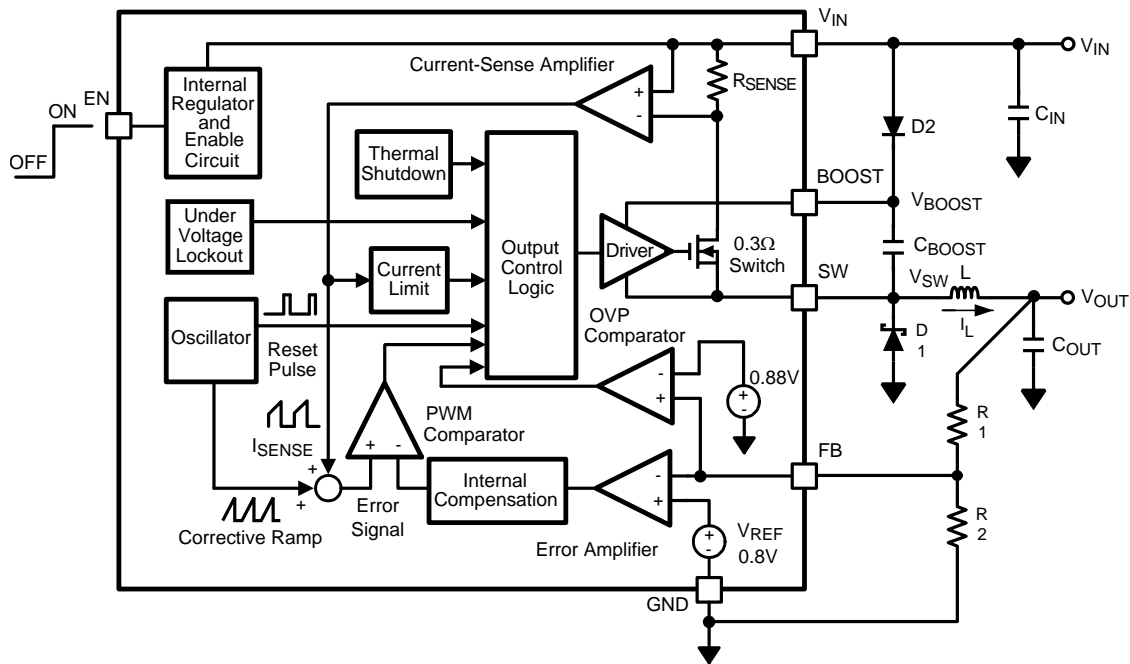

Figure 12. LM2734 Waveforms of SW Pin Voltage and Inductor Current

7.2 Functional Block Diagram



7.3 Feature Description

7.3.1 Output Overvoltage Protection

The overvoltage comparator compares the FB pin voltage to a voltage that is 10% higher than the internal reference V_{ref} . Once the FB pin voltage goes 10% above the internal reference, the internal NMOS control switch is turned off, which allows the output voltage to decrease toward regulation.

7.3.2 Undervoltage Lockout

Undervoltage lockout (UVLO) prevents the LM2734 from operating until the input voltage exceeds 2.74 V (typical).

The UVLO threshold has approximately 440 mV of hysteresis, so the part will operate until V_{IN} drops below 2.3 V (typical). Hysteresis prevents the part from turning off during power up if V_{IN} is nonmonotonic.

7.3.3 Current Limit

The LM2734 device uses cycle-by-cycle current limiting to protect the output switch. During each switching cycle, a current limit comparator detects if the output switch current exceeds 1.7 A (typical), and turns off the switch until the next switching cycle begins.

7.3.4 Thermal Shutdown

Thermal shutdown limits total power dissipation by turning off the output switch when the IC junction temperature exceeds 165°C. After thermal shutdown occurs, the output switch does not turn on until the junction temperature drops to approximately 150°C.

7.4 Device Functional Modes

7.4.1 Enable Pin / Shutdown Mode

The LM2734 device has a shutdown mode that is controlled by the enable pin (EN). When a logic low voltage is applied to EN, the part is in shutdown mode and its quiescent current drops to typically 30 nA. Switch leakage adds another 40 nA from the input supply. The voltage at this pin should never exceed $V_{IN} + 0.3$ V.

7.4.2 Soft-Start

This function forces V_{OUT} to increase at a controlled rate during start up. During soft-start, the error amplifier's reference voltage ramps from 0 V to its nominal value of 0.8 V in approximately 200 μ s. This forces the regulator output to ramp up in a more linear and controlled fashion, which helps reduce inrush current. Under some circumstances at start-up, an output voltage overshoot may still be observed. This may be due to a large output load applied during start up. Large amounts of output external capacitance can also increase output voltage overshoot. A simple solution is to add a feed forward capacitor with a value between 470 pf and 1000 pf across the top feedback resistor (R1). See [Figure 23](#) for further detail.

8 Application and Implementation

NOTE

Information in the following applications sections is not part of the TI component specification, and TI does not warrant its accuracy or completeness. TI's customers are responsible for determining suitability of components for their purposes. Customers should validate and test their design implementation to confirm system functionality.

8.1 Application Information

8.1.1 Boost Function

Capacitor C_{BOOST} and diode D2 in Figure 13 are used to generate a voltage V_{BOOST} . $V_{\text{BOOST}} - V_{\text{SW}}$ is the gate drive voltage to the internal NMOS control switch. To properly drive the internal NMOS switch during its on-time, V_{BOOST} needs to be at least 1.6 V greater than V_{SW} . Although the LM2734 device will operate with this minimum voltage, it may not have sufficient gate drive to supply large values of output current. Therefore, it is recommended that V_{BOOST} be greater than 2.5 V above V_{SW} for best efficiency. $V_{\text{BOOST}} - V_{\text{SW}}$ should not exceed the maximum operating limit of 5.5 V.

$5.5 \text{ V} > V_{\text{BOOST}} - V_{\text{SW}} > 2.5 \text{ V}$ for best performance.

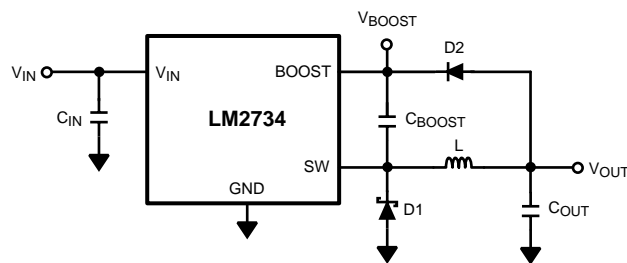

Figure 13. V_{OUT} Charges C_{BOOST}

When the LM2734 device starts up, internal circuitry from the BOOST pin supplies a maximum of 20 mA to C_{BOOST} . This current charges C_{BOOST} to a voltage sufficient to turn the switch on. The BOOST pin will continue to source current to C_{BOOST} until the voltage at the feedback pin is greater than 0.76 V.

There are various methods to derive V_{BOOST} :

1. From the input voltage (V_{IN})
2. From the output voltage (V_{OUT})
3. From an external distributed voltage rail (V_{EXT})
4. From a shunt or series Zener diode

In the simplified block diagram of *Functional Block Diagram*, capacitor C_{BOOST} and diode D2 supply the gate-drive current for the NMOS switch. Capacitor C_{BOOST} is charged via diode D2 by V_{IN} . During a normal switching cycle, when the internal NMOS control switch is off (T_{OFF}) (refer to Figure 12), V_{BOOST} equals V_{IN} minus the forward voltage of D2 (V_{FD2}), during which the current in the inductor (L) forward biases the Schottky diode D1 (V_{FD1}). Therefore the voltage stored across C_{BOOST} is:

$$V_{\text{BOOST}} - V_{\text{SW}} = V_{\text{IN}} - V_{\text{FD2}} + V_{\text{FD1}} \quad (1)$$

When the NMOS switch turns on (T_{ON}), the switch pin rises to:

$$V_{\text{SW}} = V_{\text{IN}} - (R_{\text{DSON}} \times I_{\text{L}}), \quad (2)$$

forcing V_{BOOST} to rise thus reverse biasing D2. The voltage at V_{BOOST} is then:

$$V_{\text{BOOST}} = 2V_{\text{IN}} - (R_{\text{DSON}} \times I_{\text{L}}) - V_{\text{FD2}} + V_{\text{FD1}} \quad (3)$$

which is approximately:

$$2V_{\text{IN}} - 0.4 \text{ V} \quad (4)$$

Application Information (continued)

for many applications. Thus the gate-drive voltage of the NMOS switch is approximately:

$$V_{IN} - 0.2 \text{ V} \quad (5)$$

An alternate method for charging C_{BOOST} is to connect D2 to the output as shown in [Figure 13](#). The output voltage should be from 2.5 V and 5.5 V, so that proper gate voltage will be applied to the internal switch. In this circuit, C_{BOOST} provides a gate drive voltage that is slightly less than V_{OUT} .

In applications where both V_{IN} and V_{OUT} are greater than 5.5 V, or less than 3 V, C_{BOOST} cannot be charged directly from these voltages. If V_{IN} to V_{OUT} are greater than 5.5 V, C_{BOOST} can be charged from V_{IN} or V_{OUT} minus a Zener voltage by placing a Zener diode D3 in series with D2, as shown in [Figure 14](#). When using a series Zener diode from the input, ensure that the regulation of the input supply does not create a voltage that falls outside the recommended V_{BOOST} voltage.

$$(V_{INMAX} - V_{D3}) < 5.5 \text{ V} \quad (6)$$

$$(V_{INMIN} - V_{D3}) > 1.6 \text{ V} \quad (7)$$

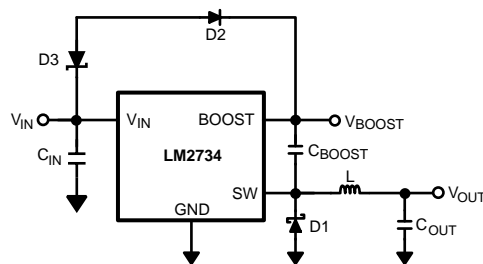

Figure 14. Zener Reduces Boost Voltage from V_{IN}

An alternative method is to place the Zener diode D3 in a shunt configuration as shown in [Figure 15](#). A small 350 mW to 500 mW 5.1-V Zener diode in a SOT or SOD package can be used for this purpose. A small ceramic capacitor such as a 6.3 V, 0.1- μ F capacitor (C_4) should be placed in parallel with the Zener diode. When the internal NMOS switch turns on, a pulse of current is drawn to charge the internal NMOS gate capacitance. The 0.1- μ F parallel shunt capacitor ensures that the V_{BOOST} voltage is maintained during this time.

Resistor R3 should be chosen to provide enough RMS current to the Zener diode (D3) and to the BOOST pin. A recommended choice for the Zener current (I_{ZENER}) is 1 mA. The current I_{BOOST} into the BOOST pin supplies the gate current of the NMOS control switch and varies typically according to the following formula for the X version:

$$I_{BOOST} = 0.56 \times (D + 0.54) \times (V_{ZENER} - V_{D2}) \text{ mA} \quad (8)$$

I_{BOOST} can be calculated for the Y version using the following:

$$I_{BOOST} = 0.22 \times (D + 0.54) \times (V_{ZENER} - V_{D2}) \mu\text{A} \quad (9)$$

where D is the duty cycle, V_{ZENER} and V_{D2} are in volts, and I_{BOOST} is in milliamps. V_{ZENER} is the voltage applied to the anode of the boost diode (D2), and V_{D2} is the average forward voltage across D2. Note that this formula for I_{BOOST} gives typical current. For the worst case I_{BOOST} , increase the current by 40%. In that case, the worst case boost current will be:

$$I_{BOOST-MAX} = 1.4 \times I_{BOOST} \quad (10)$$

R3 will then be given by:

$$R3 = (V_{IN} - V_{ZENER}) / (1.4 \times I_{BOOST} + I_{ZENER}) \quad (11)$$

For example, using the X-version let $V_{IN} = 10 \text{ V}$, $V_{ZENER} = 5 \text{ V}$, $V_{D2} = 0.7 \text{ V}$, $I_{ZENER} = 1 \text{ mA}$, and duty cycle D = 50%. Then:

$$I_{BOOST} = 0.56 \times (0.5 + 0.54) \times (5 - 0.7) \text{ mA} = 2.5 \text{ mA} \quad (12)$$

$$R3 = (10 \text{ V} - 5 \text{ V}) / (1.4 \times 2.5 \text{ mA} + 1 \text{ mA}) = 1.11 \text{ k}\Omega \quad (13)$$

Application Information (continued)

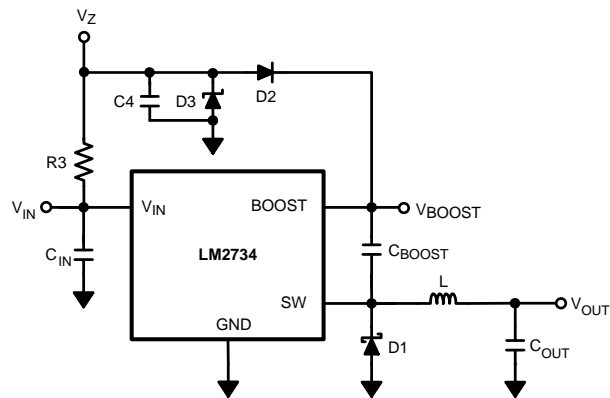

Figure 15. Boost Voltage Supplied from the Shunt Zener on V_{IN}

8.2 Typical Applications

8.2.1 LM2734X (1.6 MHz) V_{BOOST} Derived from V_{IN} 5V to 1.5 V/1 A

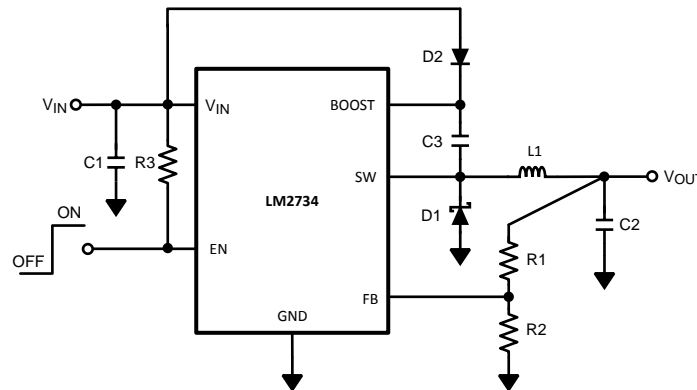

Figure 16. LM2734X (1.6 MHz) V_{BOOST} Derived from V_{IN} 5 V to 1.5-V/1-A Schematic

8.2.1.1 Design Requirements

Derive charge for V_{BOOST} from the input supply (V_{IN}). $V_{\text{BOOST}} - V_{\text{SW}}$ should not exceed the maximum operating limit of 5.5V.

8.2.1.2 Detailed Design Procedure

Table 1. Bill of Materials for Figure 16

PART ID	PART VALUE	MANUFACTURER	PART NUMBER
U1	1-A Buck Regulator	Texas Instruments	LM2734X
C1, Input Cap	10 μF , 6.3V, X5R	TDK	C3216X5ROJ106M
C2, Output Cap	10 μF , 6.3V, X5R	TDK	C3216X5ROJ106M
C3, Boost Cap	0.01 μF , 16V, X7R	TDK	C1005X7R1C103K
D1, Catch Diode	0.3 V_{F} Schottky 1 A, 10 VR	ON Semi	MBRM110L
D2, Boost Diode	1 V_{F} @ 50-mA Diode	Diodes, Inc.	1N4148W
L1	4.7 μH , 1.7A,	TDK	VLCF4020T- 4R7N1R2
R1	8.87 k Ω , 1%	Vishay	CRCW06038871F
R2	10.2 k Ω , 1%	Vishay	CRCW06031022F
R3	100 k Ω , 1%	Vishay	CRCW06031003F

8.2.1.2.1 Inductor Selection

The Duty Cycle (D) can be approximated quickly using the ratio of output voltage (V_{O}) to input voltage (V_{IN}):

$$D = \frac{V_{\text{O}}}{V_{\text{IN}}} \quad (14)$$

The catch diode (D1) forward voltage drop and the voltage drop across the internal NMOS must be included to calculate a more accurate duty cycle. Calculate D by using the following formula:

$$D = \frac{V_{\text{O}} + V_{\text{D}}}{V_{\text{IN}} + V_{\text{D}} - V_{\text{SW}}} \quad (15)$$

V_{SW} can be approximated by:

$$V_{\text{SW}} = I_{\text{O}} \times R_{\text{DS(ON)}} \quad (16)$$

The diode forward drop (V_D) can range from 0.3 V to 0.7 V depending on the quality of the diode. The lower V_D is, the higher the operating efficiency of the converter.

The inductor value determines the output ripple current. Lower inductor values decrease the size of the inductor, but increase the output ripple current. An increase in the inductor value will decrease the output ripple current. The ratio of ripple current (ΔI_L) to output current (I_O) is optimized when it is set between 0.3 and 0.4 at 1 A. The ratio r is defined as:

$$r = \frac{\Delta I_L}{I_O} \quad (17)$$

One must also ensure that the minimum current limit (1.2 A) is not exceeded, so the peak current in the inductor must be calculated. The peak current (I_{LPK}) in the inductor is calculated as shown in [Equation 18](#):

$$I_{LPK} = I_O + \Delta I_L/2 \quad (18)$$

If $r = 0.5$ at an output of 1 A, the peak current in the inductor will be 1.25 A. The minimum specified current limit over all operating conditions is 1.2 A. One can either reduce r to 0.4 resulting in a 1.2-A peak current, or make the engineering judgement that 50 mA over will be safe enough with a 1.7-A typical current limit and 6 sigma limits. When the designed maximum output current is reduced, the ratio r can be increased. At a current of 0.1 A, r can be made as high as 0.9. The ripple ratio can be increased at lighter loads because the net ripple is actually quite low, and if r remains constant the inductor value can be made quite large. An equation empirically developed for the maximum ripple ratio at any current less than 2 A is:

$$r = 0.387 \times I_{OUT}^{-0.3667} \quad (19)$$

Note that this is just a guideline.

The LM2734 device operates at frequencies allowing the use of ceramic output capacitors without compromising transient response. Ceramic capacitors allow higher inductor ripple without significantly increasing output ripple. See [Output Capacitor](#) for more details on calculating output voltage ripple.

Now that the ripple current or ripple ratio is determined, the inductance is calculated as shown in [Equation 20](#):

$$L = \frac{V_O + V_D}{I_O \times r \times f_s} \times (1-D)$$

where

- f_s is the switching frequency
 - I_O is the output current.
- (20)

When selecting an inductor, make sure that it is capable of supporting the peak output current without saturating. Inductor saturation will result in a sudden reduction in inductance and prevent the regulator from operating correctly. Because of the speed of the internal current limit, it necessary to specify the peak current of the inductor only for the required maximum output current. For example, if the designed maximum output current is 0.5 A and the peak current is 0.7 A, then the inductor should be specified with a saturation current limit of >0.7 A. There is no need to specify the saturation or peak current of the inductor at the 1.7-A typical switch current limit. The difference in inductor size is a factor of 5. Because of the operating frequency of the LM2734, ferrite based inductors are preferred to minimize core losses. This presents little restriction because the variety of ferrite based inductors is huge. Lastly, inductors with lower series resistance (DCR) will provide better operating efficiency. For recommended inductors see example circuits.

8.2.1.2.2 Input Capacitor

An input capacitor is necessary to ensure that V_{IN} does not drop excessively during switching transients. The primary specifications of the input capacitor are capacitance, voltage, RMS current rating, and ESL (Equivalent Series Inductance). The recommended input capacitance is 10 μF , although 4.7 μF is sufficient for input voltages below 6 V. The input voltage rating is specifically stated by the capacitor manufacturer. Make sure to check any recommended deratings and also verify if there is any significant change in capacitance at the operating input voltage and the operating temperature. The input capacitor maximum RMS input current rating (I_{RMS-IN}) must be greater than:

$$I_{RMS-IN} = I_O \times \sqrt{D \times \left(1-D + \frac{r^2}{12}\right)} \quad (21)$$

From Equation 21 from the above equation that maximum RMS capacitor current occurs when $D = 0.5$. Always calculate the RMS at the point where the duty cycle, D , is closest to 0.5. The ESL of an input capacitor is usually determined by the effective cross sectional area of the current path. A large leaded capacitor will have high ESL and a 0805 ceramic chip capacitor will have very low ESL. At the operating frequencies of the LM2734 device, certain capacitors may have an ESL so large that the resulting impedance ($2\pi fL$) will be higher than that required to provide stable operation. As a result, surface-mount capacitors are strongly recommended. Sanyo POSCAP, Tantalum or Niobium, Panasonic SP or Cornell Dubilier ESR, and multilayer ceramic capacitors (MLCC) are all good choices for both input and output capacitors and have very low ESL. For MLCCs it is recommended to use X7R or X5R dielectrics. Consult the capacitor manufacturer data sheet to see how rated capacitance varies over operating conditions.

8.2.1.2.3 Output Capacitor

The output capacitor is selected based upon the desired output ripple and transient response. The initial current of a load transient is provided mainly by the output capacitor. The output ripple of the converter is:

$$\Delta V_O = \Delta i_L \times \left(R_{ESR} + \frac{1}{8 \times f_s \times C_O} \right) \quad (22)$$

When using MLCCs, the ESR is typically so low that the capacitive ripple may dominate. When this occurs, the output ripple will be approximately sinusoidal and 90° phase shifted from the switching action. Given the availability and quality of MLCCs and the expected output voltage of designs using the LM2734 device, there is really no need to review any other capacitor technologies. Another benefit of ceramic capacitors is their ability to bypass high frequency noise. A certain amount of switching edge noise will couple through parasitic capacitances in the inductor to the output. A ceramic capacitor will bypass this noise while a tantalum will not. Because the output capacitor is one of the two external components that control the stability of the regulator control loop, most applications will require a minimum at 10 μF of output capacitance. Capacitance can be increased significantly with little detriment to the regulator stability. Like the input capacitor, recommended multilayer ceramic capacitors are X7R or X5R. Again, verify actual capacitance at the desired operating voltage and temperature.

Check the RMS current rating of the capacitor. The RMS current rating of the capacitor chosen must also meet the following condition:

$$I_{\text{RMS-OUT}} = I_O \times \frac{r}{\sqrt{12}} \quad (23)$$

8.2.1.2.4 Catch Diode

The catch diode (D1) conducts during the switch off-time. A Schottky diode is recommended for its fast switching times and low forward voltage drop. The catch diode should be chosen so that its current rating is greater than:

$$I_{D1} = I_O \times (1-D) \quad (24)$$

The reverse breakdown rating of the diode must be at least the maximum input voltage plus appropriate margin. To improve efficiency choose a Schottky diode with a low forward voltage drop.

8.2.1.2.5 Boost Diode

A standard diode such as the 1N4148 type is recommended. For V_{BOOST} circuits derived from voltages less than 3.3 V, a small-signal Schottky diode is recommended for greater efficiency. A good choice is the BAT54 small signal diode.

8.2.1.2.6 Boost Capacitor

A ceramic 0.01- μF capacitor with a voltage rating of at least 16 V is sufficient. The X7R and X5R MLCCs provide the best performance.

8.2.1.2.7 Output Voltage

The output voltage is set using the following equation where R2 is connected between the FB pin and GND, and R1 is connected between V_O and the FB pin. A good value for R2 is 10 kΩ.

$$R1 = \left(\frac{V_O}{V_{REF}} - 1 \right) \times R2 \tag{25}$$

8.2.1.3 Application Curves

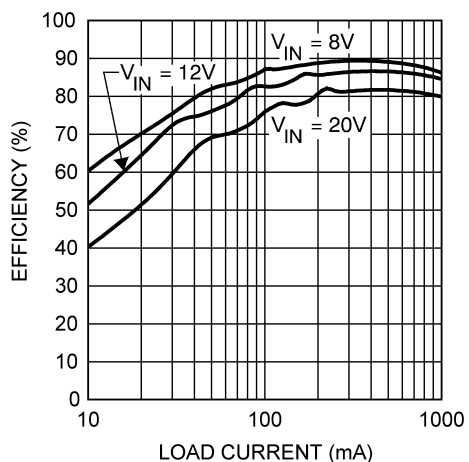

Figure 17. Efficiency vs Load Current - L1 = 4.7 μH V_{OUT} = 5 V

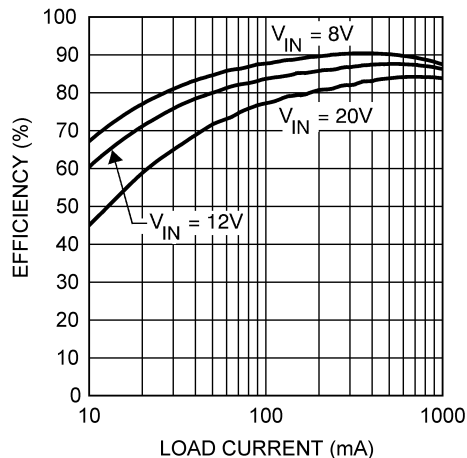

Figure 18. Efficiency vs Load Current - L1 = 10 μH V_{OUT} = 5 V

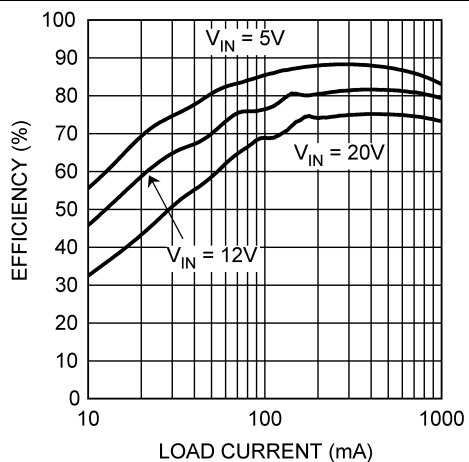

Figure 19. Efficiency vs Load Current - L1 = 4.7 μH V_{OUT} = 3.3 V

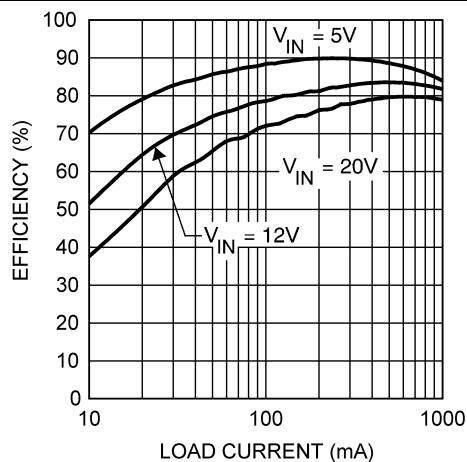

Figure 20. Efficiency vs Load Current - L1 = 10 μH V_{OUT} = 3.3 V

LM2734

SNVS288J – SEPTEMBER 2004 – REVISED DECEMBER 2014

www.ti.com

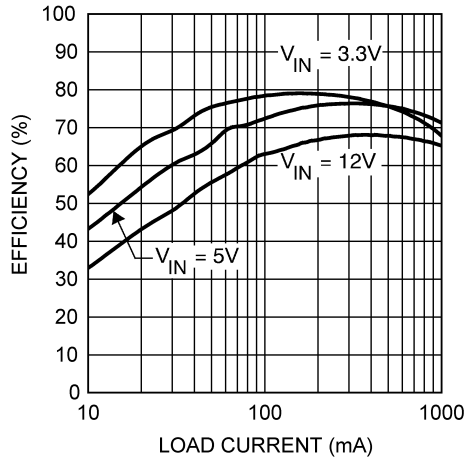

Figure 21. Efficiency vs Load Current - L1 = 4.7 μH V_{OUT} = 1.5 V

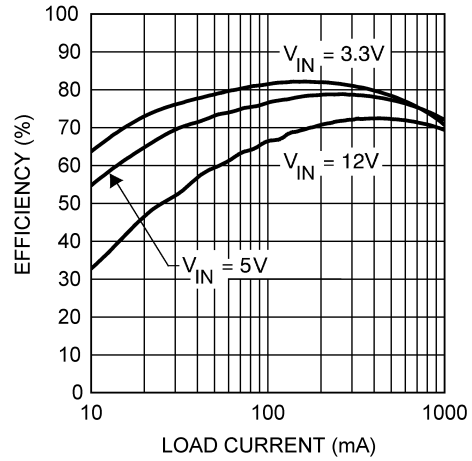

Figure 22. Efficiency vs Load Current - L1 = 10 μH V_{OUT} = 1.5 V

8.2.2 LM2734X (1.6 MHz) V_{BOOST} Derived from V_{OUT} 12 V to 3.3 V /1 A

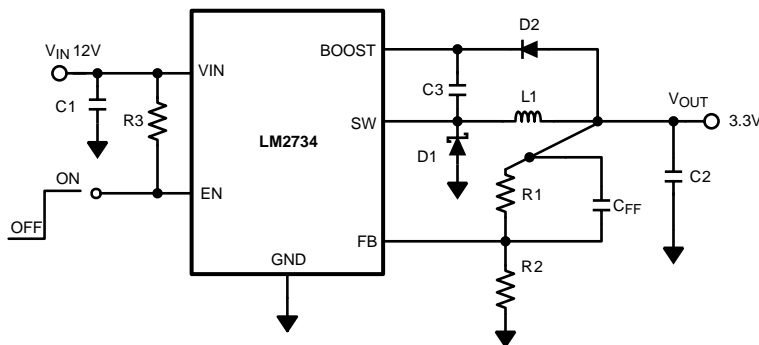

Figure 23. LM2734X (1.6 MHz) V_{BOOST} Derived from V_{OUT} 12 V to 3.3 V /1-A Schematic

8.2.2.1 Design Requirements

Derive charge for V_{BOOST} from the output voltage, (V_{OUT}). The output voltage should be between 2.5 V and 5.5 V.

8.2.2.2 Detailed Design Procedure

See [Detailed Design Procedure](#).

Table 2. Bill of Materials for Figure 23

PART ID	PART VALUE	MANUFACTURER	PART NUMBER
U1	1-A Buck Regulator	Texas Instruments	LM2734X
C1, Input Cap	10 µF, 25 V, X7R	TDK	C3225X7R1E106M
C2, Output Cap	22 µF, 6.3 V, X5R	TDK	C3216X5ROJ226M
C3, Boost Cap	0.01 µF, 16 V, X7R	TDK	C1005X7R1C103K
CFF	1000 pF 25 V	TDK	C0603X5R1E102K
D1, Catch Diode	0.34 V_F Schottky 1 A, 30 VR	Vishay	SS1P3L
D2, Boost Diode	1 V_F @ 50-mA Diode	Diodes, Inc.	1N4148W
L1	4.7µH, 1.7 A	TDK	VLCF4020T- 4R7N1R2
R1	31.6 kΩ, 1%	Vishay	CRCW06033162F
R2	10 kΩ, 1%	Vishay	CRCW06031002F
R3	100 kΩ, 1%	Vishay	CRCW06031003F

8.2.2.3 Application Curves

See [Application Curves](#).

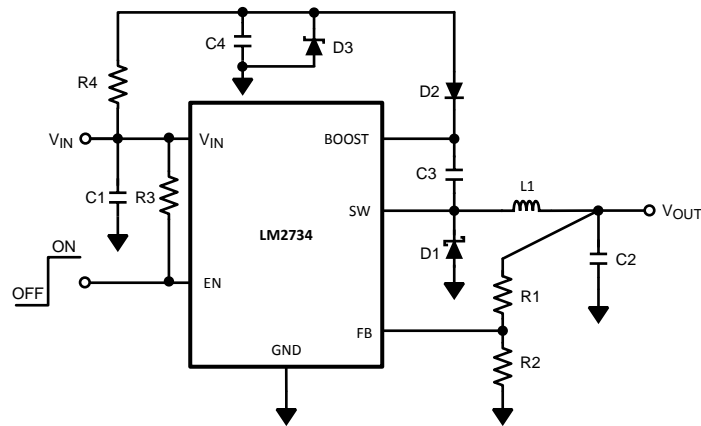
8.2.3 LM2734X (1.6 MHz) V_{BOOST} Derived from V_{SHUNT} 18 V to 1.5 V /1 A

Figure 24. LM2734X (1.6 MHz) V_{BOOST} Derived from V_{SHUNT} 18 V to 1.5 V /1-A Schematic
8.2.3.1 Design Requirements

An alternative method when V_{IN} is greater than 5.5 V is to place the zener diode D3 in a shunt configuration. A small 350 mW to 500 mW 5.1 V zener in a SOT or SOD package can be used for this purpose. A small ceramic capacitor such as a 6.3 V, 0.1 μF capacitor (C4) should be placed in parallel with the zener diode. When the internal NMOS switch turns on, a pulse of current is drawn to charge the internal NMOS gate capacitance. The 0.1 μF parallel shunt capacitor ensures that the V_{BOOST} voltage is maintained during this time.

8.2.3.2 Detailed Design Procedure

See [Detailed Design Procedure](#).

Table 3. Bill of Materials for Figure 24

PART ID	PART VALUE	MANUFACTURER	PART NUMBER
U1	1-A Buck Regulator	Texas Instruments	LM2734X
C1, Input Cap	10 μF , 25 V, X7R	TDK	C3225X7R1E106M
C2, Output Cap	22 μF , 6.3 V, X5R	TDK	C3216X5ROJ226M
C3, Boost Cap	0.01 μF , 16 V, X7R	TDK	C1005X7R1C103K
C4, Shunt Cap	0.1 μF , 6.3 V, X5R	TDK	C1005X5R0J104K
D1, Catch Diode	0.4 V_{F} Schottky 1 A, 30 VR	Vishay	SS1P3L
D2, Boost Diode	1 V_{F} @ 50-mA Diode	Diodes, Inc.	1N4148W
D3, Zener Diode	5.1 V 250 Mw SOT	Vishay	BZX84C5V1
L1	6.8 μH , 1.6 A,	TDK	SLF7032T-6R8M1R6
R1	8.87 $k\Omega$, 1%	Vishay	CRCW06038871F
R2	10.2 $k\Omega$, 1%	Vishay	CRCW06031022F
R3	100 $k\Omega$, 1%	Vishay	CRCW06031003F
R4	4.12 $k\Omega$, 1%	Vishay	CRCW06034121F

8.2.3.3 Application Curves

See [Application Curves](#).

8.2.4 LM2734X (1.6 MHz) V_{BOOST} Derived from Series Zener Diode (V_{IN}) 15 V to 1.5 V / 1 A

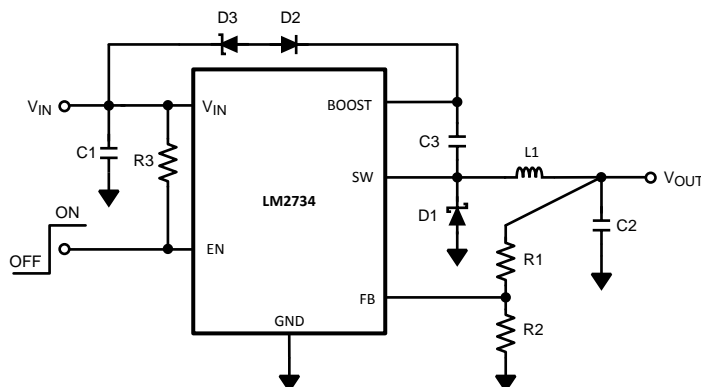

Figure 25. LM2734X (1.6 MHz) V_{BOOST} Derived from Series Zener Diode (V_{IN}) 15 V to 1.5 V / 1-A Schematic

8.2.4.1 Design Requirements

In applications where both V_{IN} and V_{OUT} are greater than 5.5 V, or less than 3 V, C_{BOOST} cannot be charged directly from these voltages. If V_{IN} is greater than 5.5 V, C_{BOOST} can be charged from V_{IN} minus a zener voltage by placing a zener diode D3 in series with D2. When using a series zener diode from the input, ensure that the regulation of the input supply doesn't create a voltage that falls outside the recommended V_{BOOST} voltage.

$$(V_{INMAX} - V_{D3}) < 5.5 \text{ V} \quad (26)$$

$$(V_{INMIN} - V_{D3}) > 1.6 \text{ V} \quad (27)$$

8.2.4.2 Detailed Design Procedure

See [Detailed Design Procedure](#).

Table 4. Bill of Materials for Figure 25

PART ID	PART VALUE	MANUFACTURER	PART NUMBER
U1	1-A Buck Regulator	Texas Instruments	LM2734X
C1, Input Cap	10 μ F, 25V, X7R	TDK	C3225X7R1E106M
C2, Output Cap	22 μ F, 6.3 V, X5R	TDK	C3216X5ROJ226M
C3, Boost Cap	0.01 μ F, 16 V, X7R	TDK	C1005X7R1C103K
D1, Catch Diode	0.4 V_F Schottky 1 A, 30 VR	Vishay	SS1P3L
D2, Boost Diode	1 V_F @ 50-mA Diode	Diodes, Inc.	1N4148W
D3, Zener Diode	11 V 350 Mw SOT	Diodes, Inc.	BZX84C11T
L1	6.8 μ H, 1.6 A,	TDK	SLF7032T-6R8M1R6
R1	8.87 k Ω , 1%	Vishay	CRCW06038871F
R2	10.2 k Ω , 1%	Vishay	CRCW06031022F
R3	100 k Ω , 1%	Vishay	CRCW06031003F

8.2.4.3 Application Curves

See [Application Curves](#).

8.2.5 LM2734X (1.6 MHz) V_{BOOST} Derived from Series Zener Diode (V_{OUT}) 15 V to 9 V / 1 A

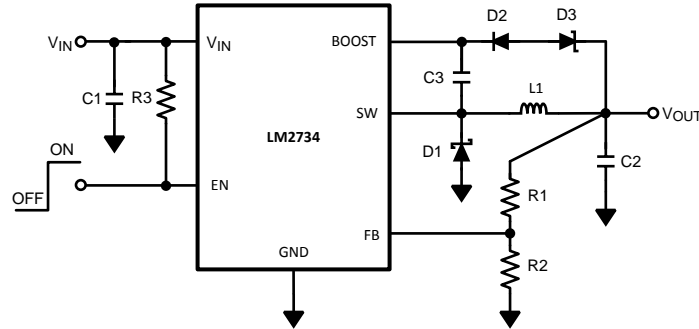

Figure 26. LM2734X (1.6 MHz) V_{BOOST} Derived from Series Zener Diode (V_{OUT}) 15 V to 9 V / 1-A Schematic

8.2.5.1 Design Requirements

In applications where both V_{IN} and V_{OUT} are greater than 5.5 V, or less than 3 V, C_{BOOST} cannot be charged directly from these voltages. If V_{IN} and V_{OUT} are greater than 5.5 V, C_{BOOST} can be charged from V_{OUT} minus a zener voltage by placing a zener diode D3 in series with D2.

8.2.5.2 Detailed Design Procedure

See [Detailed Design Procedure](#).

Table 5. Bill of Materials for Figure 26

PART ID	PART VALUE	MANUFACTURER	PART NUMBER
U1	1-A Buck Regulator	Texas Instruments	LM2734X
C1, Input Cap	10 μF , 25 V, X7R	TDK	C3225X7R1E106M
C2, Output Cap	22 μF , 16 V, X5R	TDK	C3216X5R1C226M
C3, Boost Cap	0.01 μF , 16 V, X7R	TDK	C1005X7R1C103K
D1, Catch Diode	0.4 V_{F} Schottky 1 A, 30 VR	Vishay	SS1P3L
D2, Boost Diode	1 V_{F} @ 50-mA Diode	Diodes, Inc.	1N4148W
D3, Zener Diode	4.3 V 350-mw SOT	Diodes, Inc.	BZX84C4V3
L1	6.8 μH , 1.6 A,	TDK	SLF7032T-6R8M1R6
R1	102 k Ω , 1%	Vishay	CRCW06031023F
R2	10.2 k Ω , 1%	Vishay	CRCW06031022F
R3	100 k Ω , 1%	Vishay	CRCW06031003F

8.2.5.3 Application Curves

See [Application Curves](#).

8.2.6 LM2734Y (550 kHz) V_{BOOST} Derived from V_{IN} 5 V to 1.5 V / 1 A

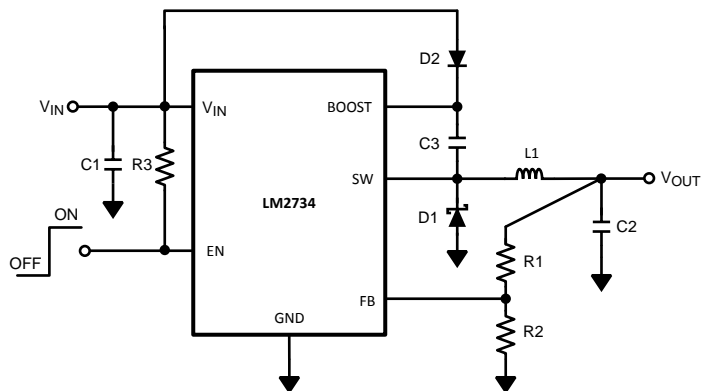

Figure 27. LM2734Y (550 kHz) V_{BOOST} Derived from V_{IN} 5 V to 1.5 V / 1-A Schematic

8.2.6.1 Design Requirements

Derive charge for V_{BOOST} from the input supply (V_{IN}). $V_{\text{BOOST}} - V_{\text{SW}}$ should not exceed the maximum operating limit of 5.5 V.

8.2.6.2 Detailed Design Procedure

See [Detailed Design Procedure](#).

Table 6. Bill of Materials for Figure 27

PART ID	PART VALUE	MANUFACTURER	PART NUMBER
U1	1-A Buck Regulator	Texas Instruments	LM2734Y
C1, Input Cap	10 μF , 6.3 V, X5R	TDK	C3216X5ROJ106M
C2, Output Cap	22 μF , 6.3 V, X5R	TDK	C3216X5ROJ226M
C3, Boost Cap	0.01 μF , 16 V, X7R	TDK	C1005X7R1C103K
D1, Catch Diode	0.3 V_F Schottky 1 A, 10 VR	ON Semi	MBRM110L
D2, Boost Diode	1 V_F @ 50-mA Diode	Diodes, Inc.	1N4148W
L1	10 μH , 1.6 A,	TDK	SLF7032T-100M1R4
R1	8.87 $\text{k}\Omega$, 1%	Vishay	CRCW06038871F
R2	10.2 $\text{k}\Omega$, 1%	Vishay	CRCW06031022F
R3	100 $\text{k}\Omega$, 1%	Vishay	CRCW06031003F

8.2.6.3 Application Curves

See [Application Curves](#).

8.2.7 LM2734Y (550 kHz) V_{BOOST} Derived from V_{OUT} 12 V to 3.3 V / 1 A

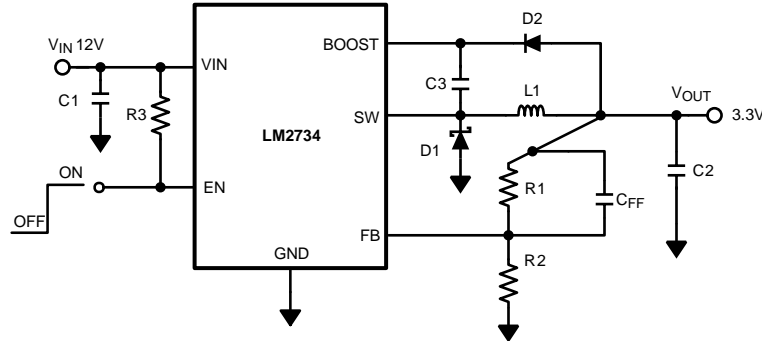

Figure 28. LM2734Y (550 kHz) V_{BOOST} Derived from V_{OUT} 12 V to 3.3 V / 1 A Schematic

8.2.7.1 Design Requirements

Derive charge for V_{BOOST} from the output voltage, (V_{OUT}). The output voltage should be between 2.5 V and 5.5 V.

8.2.7.2 Detailed Design Procedure

See [Detailed Design Procedure](#).

Table 7. Bill of Materials for [Figure 28](#)

PART ID	PART VALUE	MANUFACTURER	PART NUMBER
U1	1-A Buck Regulator	Texas Instruments	LM2734Y
C1, Input Cap	10 μF , 25 V, X7R	TDK	C3225X7R1E106M
C2, Output Cap	22 μF , 6.3 V, X5R	TDK	C3216X5ROJ226M
C3, Boost Cap	0.01 μF , 16 V, X7R	TDK	C1005X7R1C103K
D1, Catch Diode	0.34 V_F Schottky 1 A, 30VR	Vishay	SS1P3L
D2, Boost Diode	0.6 V_F @ 30-mA Diode	Vishay	BAT17
L1	10 μH , 1.6 A	TDK	SLF7032T-100M1R4
R1	31.6 k Ω , 1%	Vishay	CRCW06033162F
R2	10.0 k Ω , 1%	Vishay	CRCW06031002F
R3	100 k Ω , 1%	Vishay	CRCW06031003F

8.2.7.3 Application Curves

See [Application Curves](#).

8.2.8 LM2734Y (550 kHz) V_{BOOST} Derived from V_{SHUNT} 18 V to 1.5 V / 1 A

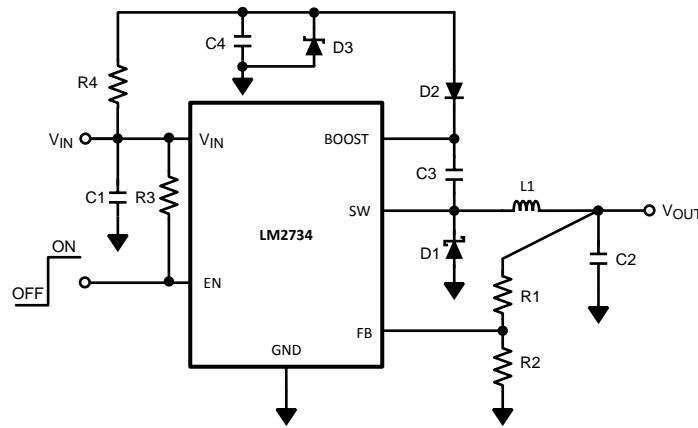

Figure 29. LM2734Y (550 kHz) V_{BOOST} Derived from V_{SHUNT} 18 V to 1.5 V / 1-A

8.2.8.1 Design Requirements

An alternative method when V_{IN} is greater than 5.5 V is to place the zener diode D3 in a shunt configuration. A small 350 mW to 500 mW 5.1 V zener in a SOT or SOD package can be used for this purpose. A small ceramic capacitor such as a 6.3 V, 0.1 μ F capacitor (C4) should be placed in parallel with the zener diode. When the internal NMOS switch turns on, a pulse of current is drawn to charge the internal NMOS gate capacitance. The 0.1 μ F parallel shunt capacitor ensures that the V_{BOOST} voltage is maintained during this time.

8.2.8.2 Detailed Design Procedure

See [Detailed Design Procedure](#).

Table 8. Bill of Materials for Figure 29

PART ID	PART VALUE	MANUFACTURER	PART NUMBER
U1	1-A Buck Regulator	Texas Instruments	LM2734Y
C1, Input Cap	10 μ F, 25 V, X7R	TDK	C3225X7R1E106M
C2, Output Cap	22 μ F, 6.3 V, X5R	TDK	C3216X5ROJ226M
C3, Boost Cap	0.01 μ F, 16 V, X7R	TDK	C1005X7R1C103K
C4, Shunt Cap	0.1 μ F, 6.3 V, X5R	TDK	C1005X5R0J104K
D1, Catch Diode	0.4 V_F Schottky 1 A, 30VR	Vishay	SS1P3L
D2, Boost Diode	1 V_F @ 50-mA Diode	Diodes, Inc.	1N4148W
D3, Zener Diode	5.1 V 250 Mw SOT	Vishay	BZX84C5V1
L1	15 μ H, 1.5 A	TDK	SLF7045T-150M1R5
R1	8.87 k Ω , 1%	Vishay	CRCW06038871F
R2	10.2 k Ω , 1%	Vishay	CRCW06031022F
R3	100 k Ω , 1%	Vishay	CRCW06031003F
R4	4.12 k Ω , 1%	Vishay	CRCW06034121F

8.2.8.3 Application Curves

See [Application Curves](#).

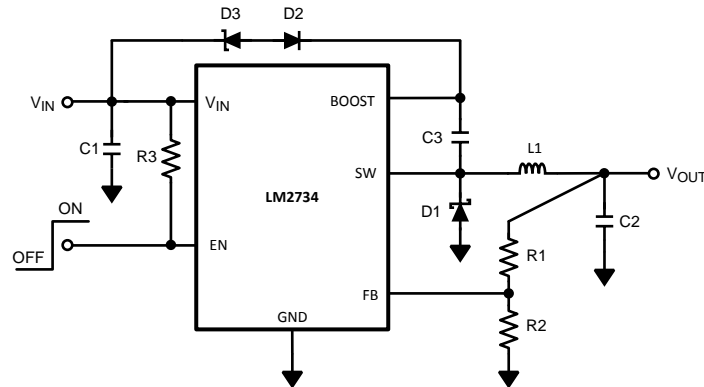
8.2.9 LM2734Y (550 kHz) V_{BOOST} Derived from Series Zener Diode (V_{IN}) 15 V to 1.5 V / 1 A

Figure 30. LM2734Y (550 kHz) V_{BOOST} Derived from Series Zener Diode (V_{IN}) 15 V to 1.5 V / 1-A Schematic
8.2.9.1 Design Requirements

In applications where both V_{IN} and V_{OUT} are greater than 5.5 V, or less than 3 V, C_{BOOST} cannot be charged directly from these voltages. If V_{IN} is greater than 5.5 V, C_{BOOST} can be charged from V_{IN} minus a zener voltage by placing a zener diode D3 in series with D2. When using a series zener diode from the input, ensure that the regulation of the input supply doesn't create a voltage that falls outside the recommended V_{BOOST} voltage.

$$(V_{INMAX} - V_{D3}) < 5.5 \text{ V} \quad (28)$$

$$(V_{INMIN} - V_{D3}) > 1.6 \text{ V} \quad (29)$$

8.2.9.2 Detailed Design Procedure

See [Detailed Design Procedure](#).

Table 9. Bill of Materials for Figure 30

PART ID	PART VALUE	MANUFACTURER	PART NUMBER
U1	1-A Buck Regulator	Texas Instruments	LM2734Y
C1, Input Cap	10 μ F, 25 V, X7R	TDK	C3225X7R1E106M
C2, Output Cap	22 μ F, 6.3 V, X5R	TDK	C3216X5ROJ226M
C3, Boost Cap	0.01 μ F, 16 V, X7R	TDK	C1005X7R1C103K
D1, Catch Diode	0.4 V _F Schottky 1 A, 30 VR	Vishay	SS1P3L
D2, Boost Diode	1 V _F @ 50-mA Diode	Diodes, Inc.	1N4148W
D3, Zener Diode	11 V 350 Mw SOT	Diodes, Inc.	BZX84C11T
L1	15 μ H, 1.5 A,	TDK	SLF7045T-150M1R5
R1	8.87 k Ω , 1%	Vishay	CRCW06038871F
R2	10.2 k Ω , 1%	Vishay	CRCW06031022F
R3	100 k Ω , 1%	Vishay	CRCW06031003F

8.2.9.3 Application Curves

See [Application Curves](#).

8.2.10 LM2734Y (550 kHz) V_{BOOST} Derived from Series Zener Diode (V_{OUT}) 15 V to 9 V / 1 A

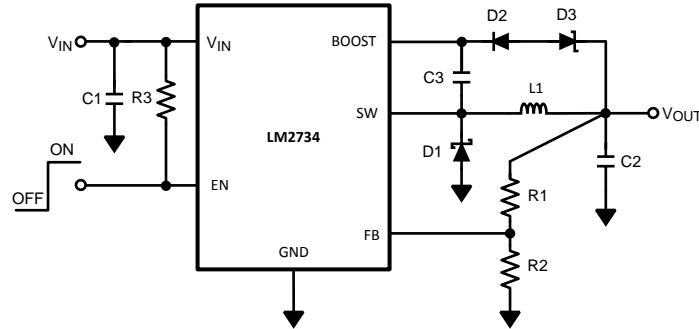

Figure 31. LM2734Y (550 kHz) V_{BOOST} Derived from Series Zener Diode (V_{OUT}) 15 V to 9 V / 1-A

8.2.10.1 Design Requirements

In applications where both V_{IN} and V_{OUT} are greater than 5.5 V, or less than 3 V, C_{BOOST} cannot be charged directly from these voltages. If V_{IN} and V_{OUT} are greater than 5.5 V, C_{BOOST} can be charged from V_{OUT} minus a zener voltage by placing a zener diode D3 in series with D2.

8.2.10.2 Detailed Design Procedure

See [Detailed Design Procedure](#).

Table 10. Bill of Materials for Figure 31

PART ID	PART VALUE	MANUFACTURER	PART NUMBER
U1	1-A Buck Regulator	Texas Instruments	LM2734Y
C1, Input Cap	10 μF , 25 V, X7R	TDK	C3225X7R1E106M
C2, Output Cap	22 μF , 16 V, X5R	TDK	C3216X5R1C226M
C3, Boost Cap	0.01 μF , 16 V, X7R	TDK	C1005X7R1C103K
D1, Catch Diode	0.4 V_{F} Schottky 1 A, 30 VR	Vishay	SS1P3L
D2, Boost Diode	1 V_{F} @ 50-mA Diode	Diodes, Inc.	1N4148W
D3, Zener Diode	4.3 V 350 Mw SOT	Diodes, Inc.	BZX84C4V3
L1	22 μH , 1.4 A,	TDK	SLF7045T-220M1R3-1PF
R1	102 k Ω , 1%	Vishay	CRCW06031023F
R2	10.2k Ω , 1%	Vishay	CRCW06031022F
R3	100k Ω , 1%	Vishay	CRCW06031003F

8.2.10.3 Application Curves

See [Application Curves](#).

9 Power Supply Recommendations

Input voltage is rated as 3 V to 18 V; however, care must be taken in certain circuit configurations (for example, V_{BOOST} derived from V_{IN} where the requirement that $V_{\text{BOOST}} - V_{\text{SW}} < 5.5 \text{ V}$ should be observed) Also, for best efficiency V_{BOOST} should be at least 2.5-V above V_{SW} .

The voltage on the Enable pin should not exceed V_{IN} by more than 0.3 V.

10 Layout

10.1 Layout Guidelines

When planning layout there are a few things to consider when trying to achieve a clean, regulated output. The most important consideration when completing the layout is the close coupling of the GND connections of the C_{IN} capacitor and the catch diode D1. These ground ends should be close to one another and be connected to the GND plane with at least two through-holes. Place these components as close to the IC as possible. Next in importance is the location of the GND connection of the C_{OUT} capacitor, which should be near the GND connections of C_{IN} and D1.

There should be a continuous ground plane on the bottom layer of a two-layer board except under the switching node island.

The FB pin is a high-impedance node and care should be taken to make the FB trace short to avoid noise pickup and inaccurate regulation. The feedback resistors should be placed as close as possible to the IC, with the GND of R2 placed as close as possible to the GND of the IC. The V_{OUT} trace to R1 should be routed away from the inductor and any other traces that are switching.

High AC currents flow through the V_{IN} , SW and V_{OUT} traces, so they should be as short and wide as possible. However, making the traces wide increases radiated noise, so the designer must make this trade-off. Radiated noise can be decreased by choosing a shielded inductor.

The remaining components should also be placed as close as possible to the IC. See Application Note AN-1229 ([SNVA054](#)) for further considerations and the LM2734 demo board as an example of a four-layer layout.

10.2 Layout Example

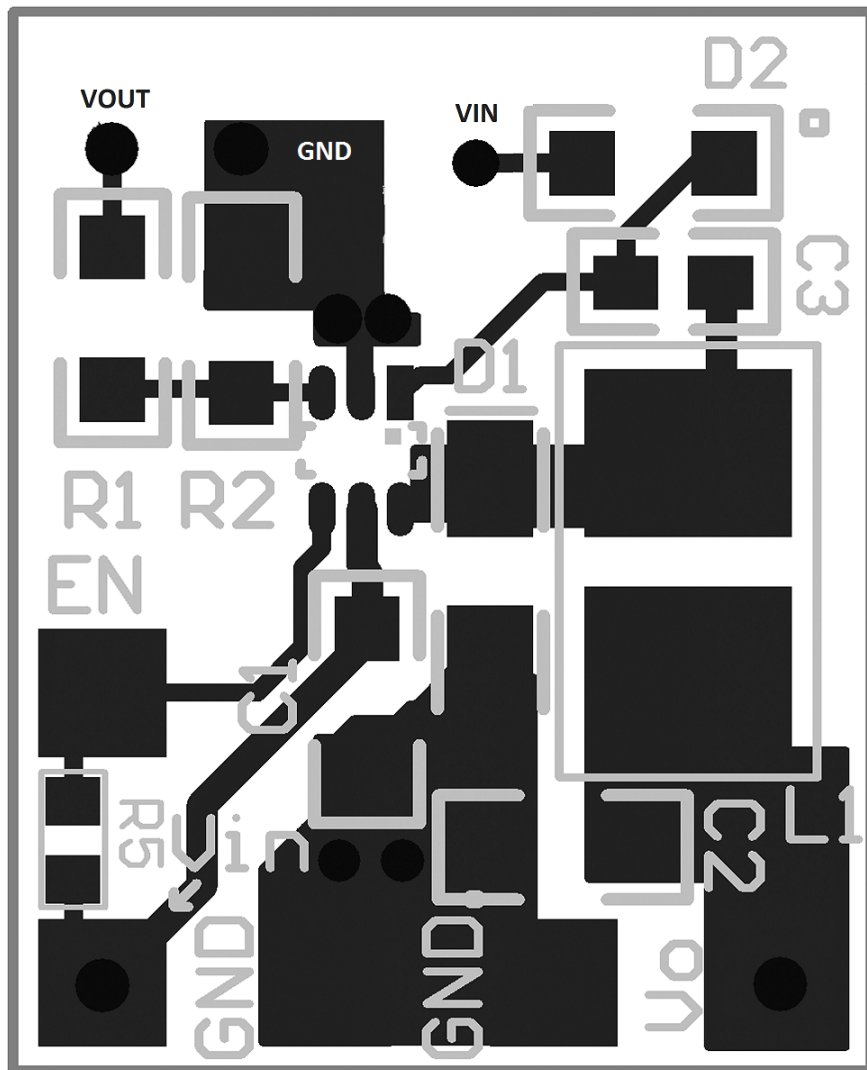

Figure 32. Top Layer

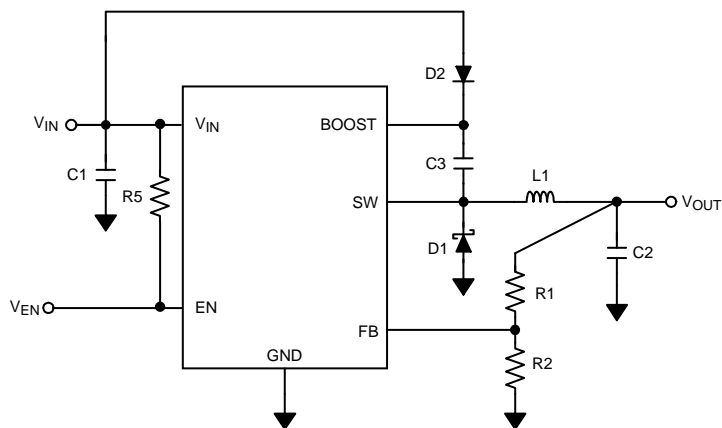

Figure 33. Layout Schematic

11 Device and Documentation Support

11.1 Third-Party Products Disclaimer

TI'S PUBLICATION OF INFORMATION REGARDING THIRD-PARTY PRODUCTS OR SERVICES DOES NOT CONSTITUTE AN ENDORSEMENT REGARDING THE SUITABILITY OF SUCH PRODUCTS OR SERVICES OR A WARRANTY, REPRESENTATION OR ENDORSEMENT OF SUCH PRODUCTS OR SERVICES, EITHER ALONE OR IN COMBINATION WITH ANY TI PRODUCT OR SERVICE.

11.2 Trademarks

WEBENCH is a registered trademark of Texas Instruments.
All other trademarks are the property of their respective owners.

11.3 Electrostatic Discharge Caution



These devices have limited built-in ESD protection. The leads should be shorted together or the device placed in conductive foam during storage or handling to prevent electrostatic damage to the MOS gates.

11.4 Glossary

[SLYZ022](#) — *TI Glossary*.

This glossary lists and explains terms, acronyms, and definitions.

12 Mechanical, Packaging, and Orderable Information

The following pages include mechanical, packaging, and orderable information. This information is the most current data available for the designated devices. This data is subject to change without notice and revision of this document. For browser-based versions of this data sheet, refer to the left-hand navigation.

PACKAGING INFORMATION

Orderable Device	Status (1)	Package Type	Package Drawing	Pins	Package Qty	Eco Plan (2)	Lead/Ball Finish (6)	MSL Peak Temp (3)	Op Temp (°C)	Device Marking (4/5)	Samples
LM2734XMK/NOPB	ACTIVE	SOT	DDC	6	1000	Green (RoHS & no Sb/Br)	CU SN	Level-1-260C-UNLIM	-40 to 125	SFDB	Samples
LM2734XMKX/NOPB	ACTIVE	SOT	DDC	6	3000	Green (RoHS & no Sb/Br)	CU SN	Level-1-260C-UNLIM	-40 to 125	SFDB	Samples
LM2734XQMK/NOPB	ACTIVE	SOT	DDC	6	1000	Green (RoHS & no Sb/Br)	CU SN	Level-1-260C-UNLIM	-40 to 125	SUKB	Samples
LM2734XQMK/NOPB	ACTIVE	SOT	DDC	6	250	Green (RoHS & no Sb/Br)	CU SN	Level-1-260C-UNLIM	-40 to 125	SUKB	Samples
LM2734XQMKX/NOPB	ACTIVE	SOT	DDC	6	3000	Green (RoHS & no Sb/Br)	CU SN	Level-1-260C-UNLIM	-40 to 125	SUKB	Samples
LM2734YMK	NRND	SOT	DDC	6	1000	TBD	Call TI	Call TI	-40 to 125	SFEB	
LM2734YMK/NOPB	ACTIVE	SOT	DDC	6	1000	Green (RoHS & no Sb/Br)	CU SN	Level-1-260C-UNLIM	-40 to 125	SFEB	Samples
LM2734YMKX/NOPB	ACTIVE	SOT	DDC	6	3000	Green (RoHS & no Sb/Br)	CU SN	Level-1-260C-UNLIM	-40 to 125	SFEB	Samples
LM2734YQMK/NOPB	ACTIVE	SOT	DDC	6	1000	Green (RoHS & no Sb/Br)	CU SN	Level-1-260C-UNLIM	-40 to 125	SVCB	Samples
LM2734YQMK/NOPB	ACTIVE	SOT	DDC	6	250	Green (RoHS & no Sb/Br)	CU SN	Level-1-260C-UNLIM	-40 to 125	SVCB	Samples
LM2734YQMKX/NOPB	ACTIVE	SOT	DDC	6	3000	Green (RoHS & no Sb/Br)	CU SN	Level-1-260C-UNLIM	-40 to 125	SVCB	Samples

(1) The marketing status values are defined as follows:

ACTIVE: Product device recommended for new designs.

LIFEBUY: TI has announced that the device will be discontinued, and a lifetime-buy period is in effect.

NRND: Not recommended for new designs. Device is in production to support existing customers, but TI does not recommend using this part in a new design.

PREVIEW: Device has been announced but is not in production. Samples may or may not be available.

OBSELETE: TI has discontinued the production of the device.

(2) Eco Plan - The planned eco-friendly classification: Pb-Free (RoHS), Pb-Free (RoHS Exempt), or Green (RoHS & no Sb/Br) - please check <http://www.ti.com/productcontent> for the latest availability information and additional product content details.

TBD: The Pb-Free/Green conversion plan has not been defined.

Pb-Free (RoHS): TI's terms "Lead-Free" or "Pb-Free" mean semiconductor products that are compatible with the current RoHS requirements for all 6 substances, including the requirement that lead not exceed 0.1% by weight in homogeneous materials. Where designed to be soldered at high temperatures, TI Pb-Free products are suitable for use in specified lead-free processes.

Pb-Free (RoHS Exempt): This component has a RoHS exemption for either 1) lead-based flip-chip solder bumps used between the die and package, or 2) lead-based die adhesive used between the die and leadframe. The component is otherwise considered Pb-Free (RoHS compatible) as defined above.

Green (RoHS & no Sb/Br): TI defines "Green" to mean Pb-Free (RoHS compatible), and free of Bromine (Br) and Antimony (Sb) based flame retardants (Br or Sb do not exceed 0.1% by weight in homogeneous material)

(3) MSL, Peak Temp. - The Moisture Sensitivity Level rating according to the JEDEC industry standard classifications, and peak solder temperature.

(4) There may be additional marking, which relates to the logo, the lot trace code information, or the environmental category on the device.

(5) Multiple Device Markings will be inside parentheses. Only one Device Marking contained in parentheses and separated by a "~" will appear on a device. If a line is indented then it is a continuation of the previous line and the two combined represent the entire Device Marking for that device.

(6) Lead/Ball Finish - Orderable Devices may have multiple material finish options. Finish options are separated by a vertical ruled line. Lead/Ball Finish values may wrap to two lines if the finish value exceeds the maximum column width.

Important Information and Disclaimer: The information provided on this page represents TI's knowledge and belief as of the date that it is provided. TI bases its knowledge and belief on information provided by third parties, and makes no representation or warranty as to the accuracy of such information. Efforts are underway to better integrate information from third parties. TI has taken and continues to take reasonable steps to provide representative and accurate information but may not have conducted destructive testing or chemical analysis on incoming materials and chemicals. TI and TI suppliers consider certain information to be proprietary, and thus CAS numbers and other limited information may not be available for release.

In no event shall TI's liability arising out of such information exceed the total purchase price of the TI part(s) at issue in this document sold by TI to Customer on an annual basis.

OTHER QUALIFIED VERSIONS OF LM2734, LM2734-Q1 :

- Catalog: [LM2734](#)
- Automotive: [LM2734-Q1](#)

NOTE: Qualified Version Definitions:

- Catalog - TI's standard catalog product
- Automotive - Q100 devices qualified for high-reliability automotive applications targeting zero defects

TAPE AND REEL INFORMATION

QUADRANT ASSIGNMENTS FOR PIN 1 ORIENTATION IN TAPE

*All dimensions are nominal

Device	Package Type	Package Drawing	Pins	SPQ	Reel Diameter (mm)	Reel Width W1 (mm)	A0 (mm)	B0 (mm)	K0 (mm)	P1 (mm)	W (mm)	Pin1 Quadrant
LM2734XMK/NOPB	SOT	DDC	6	1000	178.0	8.4	3.2	3.2	1.4	4.0	8.0	Q3
LM2734XMKX/NOPB	SOT	DDC	6	3000	178.0	8.4	3.2	3.2	1.4	4.0	8.0	Q3
LM2734XQMK/NOPB	SOT	DDC	6	1000	178.0	8.4	3.2	3.2	1.4	4.0	8.0	Q3
LM2734XQMKE/NOPB	SOT	DDC	6	250	178.0	8.4	3.2	3.2	1.4	4.0	8.0	Q3
LM2734XQMKX/NOPB	SOT	DDC	6	3000	178.0	8.4	3.2	3.2	1.4	4.0	8.0	Q3
LM2734YMK	SOT	DDC	6	1000	178.0	8.4	3.2	3.2	1.4	4.0	8.0	Q3
LM2734YMK/NOPB	SOT	DDC	6	1000	178.0	8.4	3.2	3.2	1.4	4.0	8.0	Q3
LM2734YMKX/NOPB	SOT	DDC	6	3000	178.0	8.4	3.2	3.2	1.4	4.0	8.0	Q3
LM2734YQMK/NOPB	SOT	DDC	6	1000	178.0	8.4	3.2	3.2	1.4	4.0	8.0	Q3
LM2734YQMKE/NOPB	SOT	DDC	6	250	178.0	8.4	3.2	3.2	1.4	4.0	8.0	Q3
LM2734YQMKX/NOPB	SOT	DDC	6	3000	178.0	8.4	3.2	3.2	1.4	4.0	8.0	Q3

TAPE AND REEL BOX DIMENSIONS

*All dimensions are nominal

Device	Package Type	Package Drawing	Pins	SPQ	Length (mm)	Width (mm)	Height (mm)
LM2734XMK/NOPB	SOT	DDC	6	1000	210.0	185.0	35.0
LM2734XMKX/NOPB	SOT	DDC	6	3000	210.0	185.0	35.0
LM2734XQMK/NOPB	SOT	DDC	6	1000	210.0	185.0	35.0
LM2734XQMKX/NOPB	SOT	DDC	6	250	210.0	185.0	35.0
LM2734XQMKX/NOPB	SOT	DDC	6	3000	210.0	185.0	35.0
LM2734YMK	SOT	DDC	6	1000	210.0	185.0	35.0
LM2734YMK/NOPB	SOT	DDC	6	1000	210.0	185.0	35.0
LM2734YMKX/NOPB	SOT	DDC	6	3000	210.0	185.0	35.0
LM2734YQMK/NOPB	SOT	DDC	6	1000	210.0	185.0	35.0
LM2734YQMKX/NOPB	SOT	DDC	6	250	210.0	185.0	35.0
LM2734YQMKX/NOPB	SOT	DDC	6	3000	210.0	185.0	35.0

DDC (R-PDSO-G6)

PLASTIC SMALL-OUTLINE

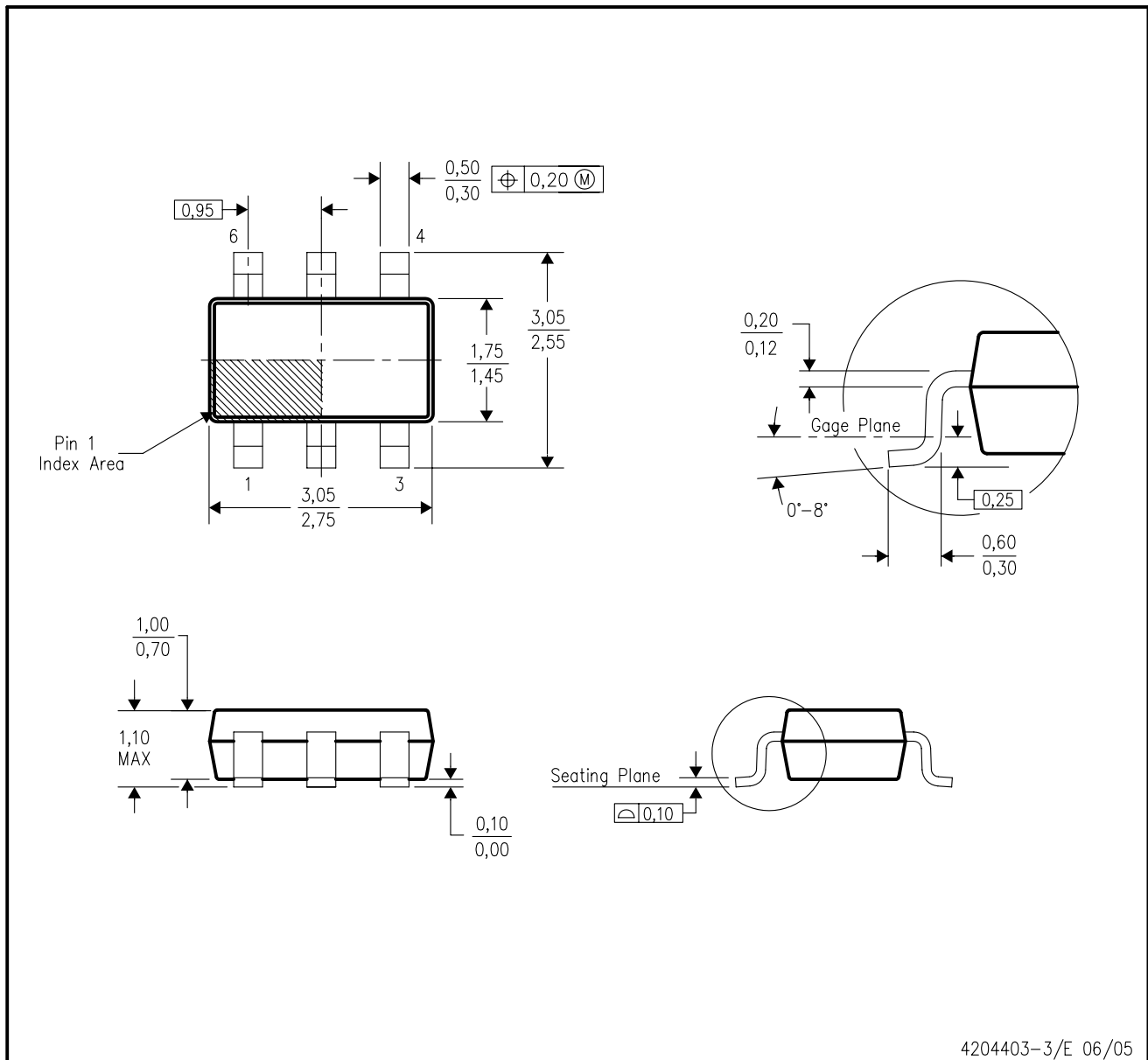

- NOTES:
- All linear dimensions are in millimeters.
 - This drawing is subject to change without notice.
 - Body dimensions do not include mold flash or protrusion.
 - Falls within JEDEC MO-193 variation AA (6 pin).

DDC (R-PDSO-G6)

PLASTIC SMALL OUTLINE

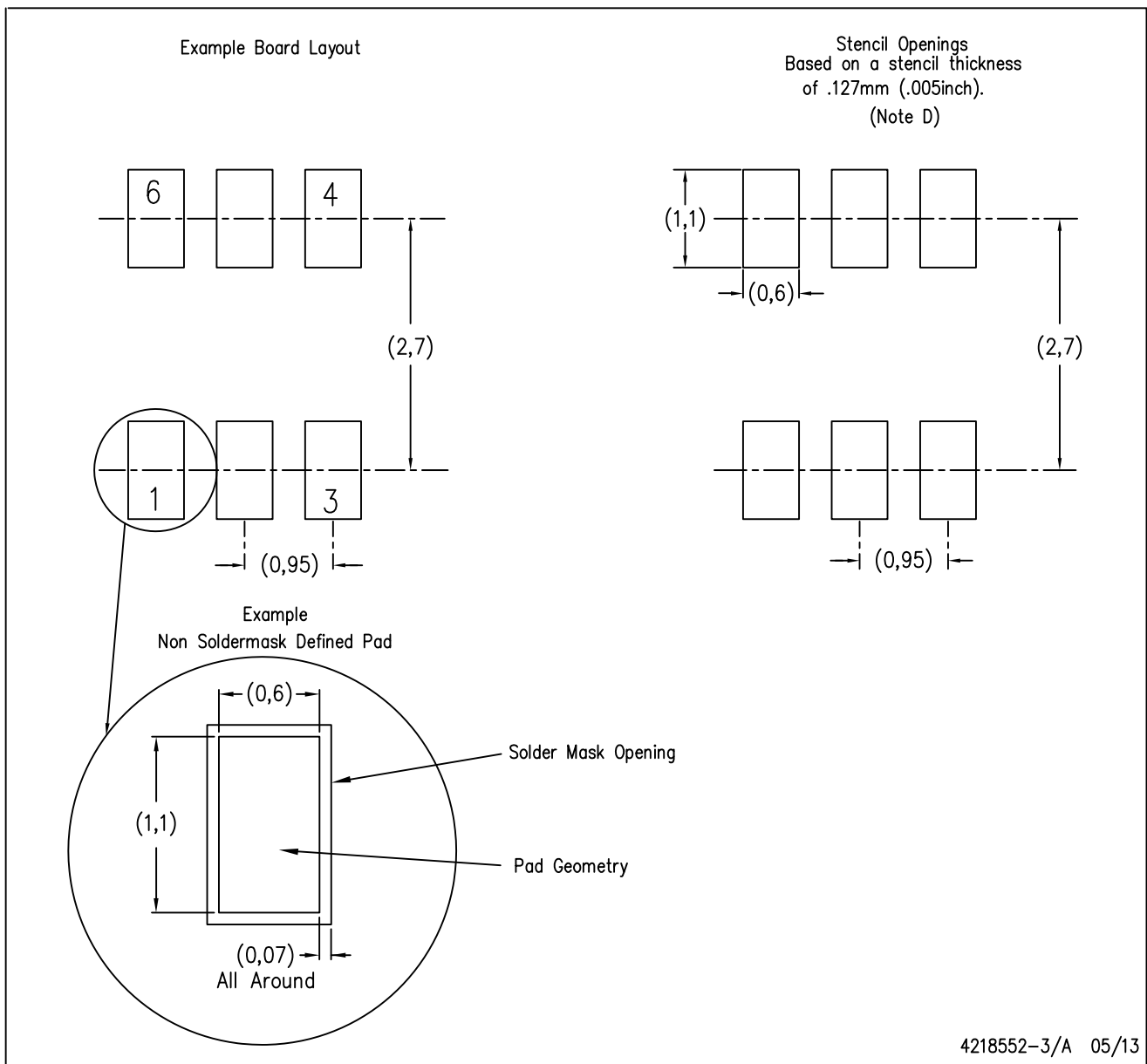

- NOTES:
- A. All linear dimensions are in millimeters.
 - B. This drawing is subject to change without notice.
 - C. Publication IPC-7351 is recommended for alternate designs.
 - D. Laser cutting apertures with trapezoidal walls and also rounding corners will offer better paste release. Customers should contact their board assembly site for stencil design recommendations. Example stencil design based on a 50% volumetric metal load solder paste. Refer to IPC-7525 for other stencil recommendations.

IMPORTANT NOTICE

Texas Instruments Incorporated and its subsidiaries (TI) reserve the right to make corrections, enhancements, improvements and other changes to its semiconductor products and services per JESD46, latest issue, and to discontinue any product or service per JESD48, latest issue. Buyers should obtain the latest relevant information before placing orders and should verify that such information is current and complete. All semiconductor products (also referred to herein as "components") are sold subject to TI's terms and conditions of sale supplied at the time of order acknowledgment.

TI warrants performance of its components to the specifications applicable at the time of sale, in accordance with the warranty in TI's terms and conditions of sale of semiconductor products. Testing and other quality control techniques are used to the extent TI deems necessary to support this warranty. Except where mandated by applicable law, testing of all parameters of each component is not necessarily performed.

TI assumes no liability for applications assistance or the design of Buyers' products. Buyers are responsible for their products and applications using TI components. To minimize the risks associated with Buyers' products and applications, Buyers should provide adequate design and operating safeguards.

TI does not warrant or represent that any license, either express or implied, is granted under any patent right, copyright, mask work right, or other intellectual property right relating to any combination, machine, or process in which TI components or services are used. Information published by TI regarding third-party products or services does not constitute a license to use such products or services or a warranty or endorsement thereof. Use of such information may require a license from a third party under the patents or other intellectual property of the third party, or a license from TI under the patents or other intellectual property of TI.

Reproduction of significant portions of TI information in TI data books or data sheets is permissible only if reproduction is without alteration and is accompanied by all associated warranties, conditions, limitations, and notices. TI is not responsible or liable for such altered documentation. Information of third parties may be subject to additional restrictions.

Resale of TI components or services with statements different from or beyond the parameters stated by TI for that component or service voids all express and any implied warranties for the associated TI component or service and is an unfair and deceptive business practice. TI is not responsible or liable for any such statements.

Buyer acknowledges and agrees that it is solely responsible for compliance with all legal, regulatory and safety-related requirements concerning its products, and any use of TI components in its applications, notwithstanding any applications-related information or support that may be provided by TI. Buyer represents and agrees that it has all the necessary expertise to create and implement safeguards which anticipate dangerous consequences of failures, monitor failures and their consequences, lessen the likelihood of failures that might cause harm and take appropriate remedial actions. Buyer will fully indemnify TI and its representatives against any damages arising out of the use of any TI components in safety-critical applications.

In some cases, TI components may be promoted specifically to facilitate safety-related applications. With such components, TI's goal is to help enable customers to design and create their own end-product solutions that meet applicable functional safety standards and requirements. Nonetheless, such components are subject to these terms.

No TI components are authorized for use in FDA Class III (or similar life-critical medical equipment) unless authorized officers of the parties have executed a special agreement specifically governing such use.

Only those TI components which TI has specifically designated as military grade or "enhanced plastic" are designed and intended for use in military/aerospace applications or environments. Buyer acknowledges and agrees that any military or aerospace use of TI components which have **not** been so designated is solely at the Buyer's risk, and that Buyer is solely responsible for compliance with all legal and regulatory requirements in connection with such use.

TI has specifically designated certain components as meeting ISO/TS16949 requirements, mainly for automotive use. In any case of use of non-designated products, TI will not be responsible for any failure to meet ISO/TS16949.

Products

Audio	www.ti.com/audio
Amplifiers	amplifier.ti.com
Data Converters	dataconverter.ti.com
DLP® Products	www.dlp.com
DSP	dsp.ti.com
Clocks and Timers	www.ti.com/clocks
Interface	interface.ti.com
Logic	logic.ti.com
Power Mgmt	power.ti.com
Microcontrollers	microcontroller.ti.com
RFID	www.ti-rfid.com
OMAP Applications Processors	www.ti.com/omap
Wireless Connectivity	www.ti.com/wirelessconnectivity

Applications

Automotive and Transportation	www.ti.com/automotive
Communications and Telecom	www.ti.com/communications
Computers and Peripherals	www.ti.com/computers
Consumer Electronics	www.ti.com/consumer-apps
Energy and Lighting	www.ti.com/energy
Industrial	www.ti.com/industrial
Medical	www.ti.com/medical
Security	www.ti.com/security
Space, Avionics and Defense	www.ti.com/space-avionics-defense
Video and Imaging	www.ti.com/video

TI E2E Community

e2e.ti.com

Looking for pricing, stock, or lifecycle information?

Click below to explore more details on WIN SOURCE:

 [View LM2734XMK/NOPB on WIN SOURCE](#)

 [Texas Instruments](#) Information

Optimize Your Supply Chain with WIN SOURCE Solutions

-  Global Sourcing Solution
-  Obsolete Management
-  Cost Control Management
-  Shortage Management
-  Alternative Solution
-  Excess Inventory Management