



THE DATASHEET OF LM2743MTCX/NOPB



LM2743 2.2-V to 16-V Input, voltage mode, synchronous buck controller with tracking

1 Features

- Power stage input voltage from 1 V to 16 V
- Control stage input voltage from 3 V to 6 V
- Output voltage adjustable down to 0.6 V
- Power-good flag and shutdown
- Output overvoltage and undervoltage detection
- $\pm 2\%$ Feedback voltage accuracy over temperature
- Low-side adjustable current sensing
- Adjustable soft start
- Tracking and sequencing with shutdown and soft-start pins
- Switching frequency from 50 kHz to 1 MHz
- TSSOP-14 package
- Create a custom design using the LM2743 with the [WEBENCH® Power Designer](#)

2 Applications

- 3.3-V Buck regulation
- Cable modem, DSL and ADSL
- Laser Jet and ink jet printers
- Low-voltage power modules
- DSP, ASIC, core, and I/O

3 Description

The LM2743 is a high-speed synchronous buck regulator controller with an accurate feedback voltage accuracy of $\pm 2\%$. It can provide simple down conversion to output voltages as low as 0.6 V. Though the control sections of the IC are rated for 3 V to 6 V, the driver sections are designed to accept input supply rails as high as 16 V. The use of adaptive non-overlapping MOSFET gate drivers helps avoid potential shoot-through problems while maintaining high efficiency. The IC is designed for the more cost-effective option of driving only N-channel MOSFETs in both the high-side and low-side positions. It senses the low-side switch voltage drop for providing a simple, adjustable current limit.

The fixed-frequency voltage-mode PWM control architecture is adjustable from 50 kHz to 1 MHz with one external resistor. This wide range of switching frequency gives the power supply designer the flexibility to make better tradeoffs between component size, cost and efficiency.

Features include soft start, input undervoltage lockout (UVLO) and Power Good (based on both undervoltage and overvoltage detection). In addition, the shutdown pin of the IC can be used for providing start-up delay, and the soft-start pin can be used for implementing precise tracking, for the purpose of sequencing with respect to an external rail.

Device Information⁽¹⁾

PART NUMBER	PACKAGE	BODY SIZE (NOM)
LM2743	TSSOP (14)	5.00 mm x 4.40 mm

(1) For all available packages, see the orderable addendum at the end of the data sheet.

Typical Application Diagram

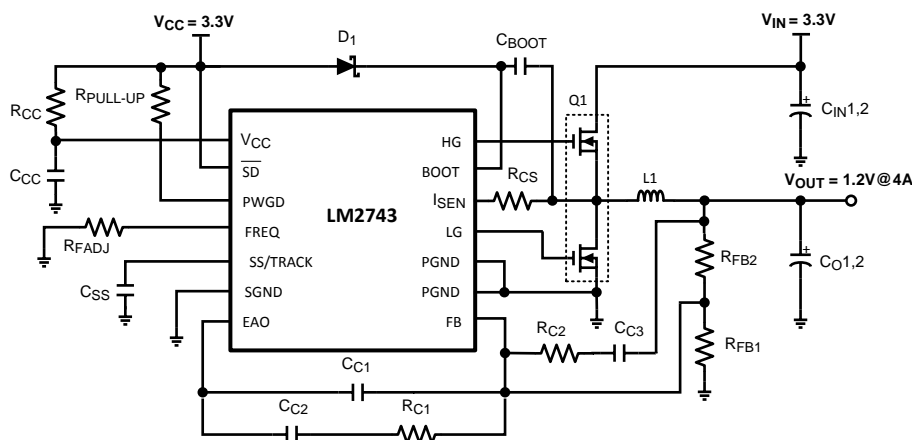

Table of Contents

1 Features 1 2 Applications 1 3 Description 1 4 Revision History 2 5 Pin Configuration and Functions 3 6 Specifications 4 6.1 Absolute Maximum Ratings 4 6.2 ESD Ratings 4 6.3 Recommended Operating Conditions 4 6.4 Thermal Information 4 6.5 Electrical Characteristics 5 6.6 Typical Characteristics 7 7 Detailed Description 10 7.1 Overview 10 7.2 Functional Block Diagram 10 7.3 Feature Description 10	7.4 Device Functional Modes 18 8 Application and Implementation 19 8.1 Application Information 19 8.2 Typical Applications 19 9 Power Supply Recommendations 33 10 Layout 33 10.1 Layout Guidelines 33 10.2 Layout Example 33 11 Device and Documentation Support 34 11.1 Device Support 34 11.2 Receiving Notification of Documentation Updates 34 11.3 Community Resources 34 11.4 Trademarks 34 11.5 Electrostatic Discharge Caution 34 11.6 Glossary 34 12 Mechanical, Packaging, and Orderable Information 35
---	--

4 Revision History

NOTE: Page numbers for previous revisions may differ from page numbers in the current version.

Changes from Revision H (October 2015) to Revision I	Page
<ul style="list-style-type: none"> • Editorial updates; add links for WEBENCH; no technical changes 1 	1
Changes from Revision G (March 2013) to Revision H	Page
<ul style="list-style-type: none"> • Added <i>ESD Ratings</i> table, <i>Feature Description</i> section, <i>Device Functional Modes</i>, <i>Application and Implementation</i> section, <i>Power Supply Recommendations</i> section, <i>Layout</i> section, <i>Device and Documentation Support</i> section, and <i>Mechanical, Packaging, and Orderable Information</i> section. 1 	1
Changes from Revision F (March 2013) to Revision G	Page
<ul style="list-style-type: none"> • Changed layout of National Data Sheet to TI format 32 	32

5 Pin Configuration and Functions

**PW Package
14-Pin TSSOP
Top View**

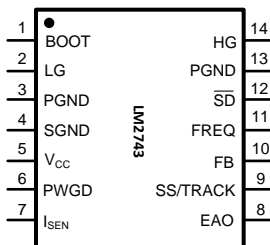

Pin Functions

PIN		DESCRIPTION
NAME	NO.	
BOOT	1	Bootstrap pin. This is the supply rail for the gate drivers. When the high-side MOSFET turns on, the voltage on this pin should be at least one gate threshold above the regulator input voltage V_{IN} to properly turn on the MOSFET. See MOSFET Gate Drivers for more details on how to select MOSFETs.
LG	2	Low-gate drive pin. This is the gate drive for the low-side N-channel MOSFET. This signal is interlocked with the high-side gate drive HG (Pin 14), so as to avoid shoot-through.
PGND	3	Power ground. This is also the ground for the low-side MOSFET driver. Both the pins must be connected together on the PCB and form a ground plane, which is usually also the system ground.
	13	
SGND	4	Signal ground. It should be connected appropriately to the ground plane with due regard to good layout practices in switching power regulator circuits.
V_{CC}	5	Supply rail for the control sections of the IC.
PWGD	6	Power Good pin. This is an open drain output, which is typically meant to be connected to V_{CC} or any other low voltage source through a pull-up resistor. Choose the pull-up resistor so that the current going into this pin is kept below 1 mA. For most applications a recommended value for the pull-up resistor is 100 k Ω . The voltage on this pin is thus pulled low under output under-voltage or over-voltage fault conditions and also under input UVLO.
I_{SEN}	7	Current limit threshold setting pin. This sources a fixed 40 μ A current. A resistor of appropriate value should be connected between this pin and the drain of the low-side MOSFET (switch node).
EAO	8	Output of the error amplifier. The voltage level on this pin is compared with an internally generated ramp signal to determine the duty cycle. This pin is necessary for compensating the control loop.
SS/TRACK	9	Soft-start and tracking pin. This pin is internally connected to the non-inverting input of the error amplifier during soft-start, and in fact any time the SS/TRACK pin voltage happens to be below the internal reference voltage. For the basic soft-start function, a capacitor of minimum value 1 nF is connected from this pin to ground. To track the rising ramp of another power supply's output, connect a resistor divider from the output of that supply to this pin as described in Application and Implementation .
FB	10	Feedback pin. This is the inverting input of the error amplifier, which is used for sensing the output voltage and compensating the control loop.
FREQ	11	Frequency adjust pin. The switching frequency is set by connecting a resistor of suitable value between this pin and ground. The equation for calculating the exact value is provided in Application and Implementation , but some typical values (rounded up to the nearest standard values) are 324 k Ω for 100 kHz, 97.6 k Ω for 300 kHz, 56.2 k Ω for 500 kHz, 24.9 k Ω for 1 MHz.
\overline{SD}	12	IC shutdown pin. Pull this pin to V_{CC} to ensure the IC is enabled. Connect to ground to disable the IC. Under shutdown, both high-side and low-side drives are off. This pin also features a precision threshold for power supply sequencing purposes, as well as a low threshold to ensure minimal quiescent current.
HG	14	High-gate drive pin. This is the gate drive for the high-side N-channel MOSFET. This signal is interlocked with LG (Pin 2) to avoid shoot-through.

6 Specifications

6.1 Absolute Maximum Ratings

		MIN	MAX	UNIT
V_{CC}		-0.3	7	V
	BOOT voltage	-0.3	21	V
I_{SEN}		-0.3	9.5	V
	All other pins	-0.3	$V_{CC} + 0.3$	V
T_J	Junction temperature		150	°C
Soldering information	Lead temperature (soldering, 10 s)		260	°C
	Infrared or convection (20 s)		235	°C
T_{stg}	Storage temperature	-65	150	°C

- Stresses beyond those listed under *Absolute Maximum Ratings* may cause permanent damage to the device. These are stress ratings only, which do not imply functional operation of the device at these or any other conditions beyond those indicated under *Recommended Operating Conditions*. Exposure to absolute-maximum-rated conditions for extended periods may affect device reliability.
- If Military/Aerospace specified devices are required, please contact the Texas Instruments Sales Office/ Distributors for availability and specifications.

6.2 ESD Ratings

			VALUE	UNIT
$V_{(ESD)}$	Electrostatic discharge ⁽¹⁾	Human-body model (HBM), per ANSI/ESDA/JEDEC JS-001 ⁽²⁾	2000	V

- The human body model is a 100 pF capacitor discharged through a 1.5-k Ω resistor into each pin.
- JEDEC document JEP155 states that 500-V HBM allows safe manufacturing with a standard ESD control process.

6.3 Recommended Operating Conditions

		MIN	NOM	MAX	UNIT
V_{CC}	Supply voltage range	3		6	V
T_J	Junction temperature	-40		125	°C

6.4 Thermal Information

THERMAL METRIC ⁽¹⁾		LM2743	UNIT
		TSSOP (PW)	
		14 PINS	
$R_{\theta JA}$	Junction-to-ambient thermal resistance	107.9	°C/W
$R_{\theta JC(top)}$	Junction-to-case (top) thermal resistance	33.7	°C/W
$R_{\theta JB}$	Junction-to-board thermal resistance	50.7	°C/W
ψ_{JT}	Junction-to-top characterization parameter	1.8	°C/W
ψ_{JB}	Junction-to-board characterization parameter	50	°C/W

- For more information about traditional and new thermal metrics, see the *Semiconductor and IC Package Thermal Metrics* application report, [SPRA953](#).

6.5 Electrical Characteristics

Typical limits are for $T_J = 25^\circ\text{C}$ only, represent the most likely parametric norm at $T_J = 25^\circ\text{C}$, and are provided for reference purposes only; minimum and maximum limits apply over the junction temperature range of -40°C to 125°C . Unless otherwise specified, $V_{CC} = 3.3\text{ V}$. Data sheet minimum and maximum specification limits are specified by design, test, or statistical analysis. (See ⁽¹⁾)

PARAMETER		TEST CONDITIONS	MIN	TYP	MAX	UNIT
V_{FB}	FB Pin Voltage	$V_{CC} = 3\text{ V to }6\text{ V}$	0.588	0.6	0.612	V
V_{ON}	UVLO Thresholds	Rising Falling		2.76 2.42		V
I_{Q_VCC}	Operating V_{CC} Current	$V_{CC} = 3.3\text{ V}, V_{SD} = 3.3\text{ V}$ $F_{SW} = 600\text{ kHz}$	1	1.5	2.1	mA
		$V_{CC} = 5\text{ V}, V_{SD} = 3.3\text{ V}$ $F_{SW} = 600\text{ kHz}$	1	1.7	2.1	
	Shutdown V_{CC} Current	$V_{CC} = 3.3\text{ V}, V_{SD} = 0\text{ V}$		110	185	μA
t_{PWGD1}	PWGD Pin Response Time	V_{FB} Rising		6		μs
t_{PWGD2}	PWGD Pin Response Time	V_{FB} Falling		6		μs
I_{SS-ON}	SS Pin Source Current	$V_{SS} = 0\text{ V}$	7	10	14	μA
I_{SS-OC}	SS Pin Sink Current During Over Current	$V_{SS} = 2.5\text{ V}$		90		μA
I_{SEN-TH}	I_{SEN} Pin Source Current Trip Point		25	40	55	μA
ERROR AMPLIFIER						
GBW	Error Amplifier Unity Gain Bandwidth			9		MHz
G	Error Amplifier DC Gain			106		dB
SR	Error Amplifier Slew Rate			3.2		V/ μs
I_{EAO}	EAO Pin Current Sourcing and Sinking Capability	$V_{EAO} = 1.5, FB = 0.55\text{ V}$ $V_{EAO} = 1.5, FB = 0.65\text{ V}$		2.6 9.2		mA
V_{EA}	Error Amplifier Output Voltage	Minimum		1		V
		Maximum		2		V
GATE DRIVE						
I_{Q-BOOT}	BOOT Pin Quiescent Current	$V_{BOOT} = 12\text{ V}, V_{SD} = 0$		18	90	μA
R_{HG_UP}	High-Side MOSFET Driver Pull-Up ON resistance	$V_{BOOT} = 5\text{ V}$ at 350 mA Sourcing		3		Ω
R_{HG_DN}	High-Side MOSFET Driver Pull-Down ON resistance	HG = 5 V at 350 mA Sourcing		2		Ω
R_{LG_UP}	Low-Side MOSFET Driver Pull-Up ON resistance	$V_{BOOT} = 5\text{ V}$ at 350 mA Sourcing		3		Ω
R_{LG_DN}	Low-Side MOSFET Driver Pull-Down ON resistance	LG = 5 V at 350 mA Sourcing		2		Ω
OSCILLATOR						
f_{SW}	PWM Frequency	$R_{FADJ} = 702.1\text{ k}\Omega$		50		kHz
		$R_{FADJ} = 98.74\text{ k}\Omega$		300		
		$R_{FADJ} = 45.74\text{ k}\Omega$	475	600	725	
		$R_{FADJ} = 24.91\text{ k}\Omega$		1000		
D	Max High-Side Duty Cycle	$f_{SW} = 300\text{ kHz}$ $f_{SW} = 600\text{ kHz}$ $f_{SW} = 1\text{ MHz}$		80% 76% 73%		
LOGIC INPUTS AND OUTPUTS						
$V_{STBY-IH}$	Standby High Trip Point	$V_{FB} = 0.575\text{ V}, V_{BOOT} = 3.3\text{ V}, V_{SD}$ Rising			1.1	V
$V_{STBY-IL}$	Standby Low Trip Point	$V_{FB} = 0.575\text{ V}, V_{BOOT} = 3.3\text{ V}, V_{SD}$ Falling	0.232			V
V_{SD-IH}	\overline{SD} Pin Logic High Trip Point	V_{SD} Rising			1.3	V

(1) The power MOSFETs can run on a separate 1-V to 16-V rail (Input voltage, V_{IN}). Practical lower limit of V_{IN} depends on selection of the external MOSFET.

Electrical Characteristics (continued)

Typical limits are for $T_J = 25^\circ\text{C}$ only, represent the most likely parametric norm at $T_J = 25^\circ\text{C}$, and are provided for reference purposes only; minimum and maximum limits apply over the junction temperature range of -40°C to 125°C . Unless otherwise specified, $V_{CC} = 3.3\text{ V}$. Data sheet minimum and maximum specification limits are specified by design, test, or statistical analysis. (See ⁽¹⁾)

PARAMETER		TEST CONDITIONS	MIN	TYP	MAX	UNIT
V_{SD-IL}	\overline{SD} Pin Logic Low Trip Point	V_{SD} Falling	0.8			V
$V_{PWGD-TH-LO}$	PWGD Pin Trip Points	FB Falling	0.408	0.434	0.457	V
$V_{PWGD-TH-HI}$	PWGD Pin Trip Points	FB Rising	0.677	0.710	0.742	V
$V_{PWGD-HYS}$	PWGD Hysteresis	FB Falling	60			mV
		FB Rising	90			

6.6 Typical Characteristics

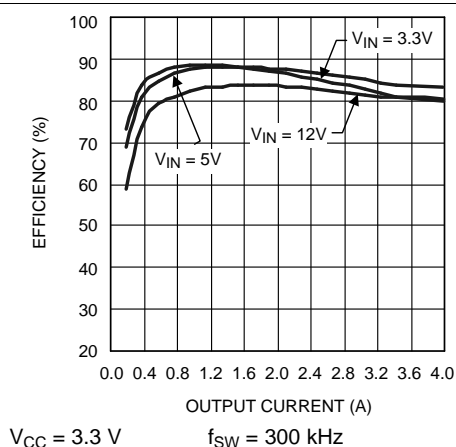

Figure 1. Efficiency $V_{OUT} = 1.2 V$

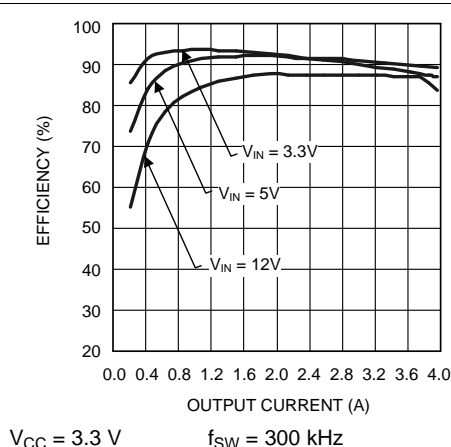

Figure 2. Efficiency $V_{OUT} = 2.5 V$

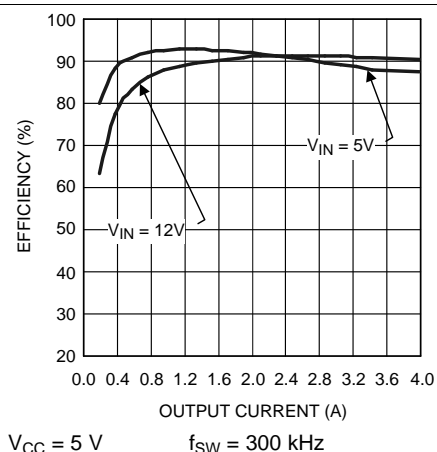

Figure 3. Efficiency $V_{OUT} = 3.3 V$

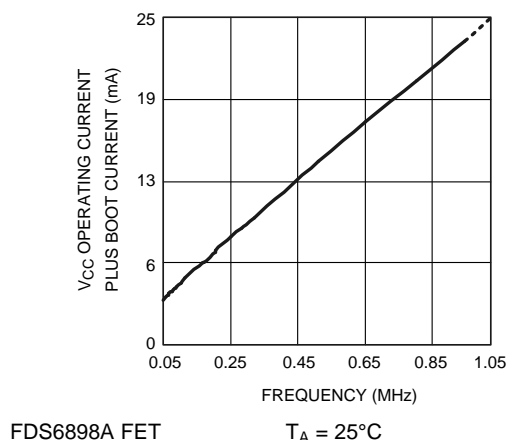

Figure 4. V_{CC} Operating Current Plus BOOT Current vs Frequency

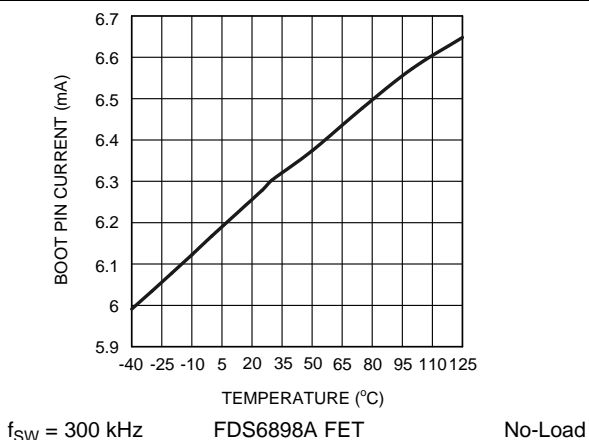

Figure 5. BOOT Pin Current vs Temperature for BOOT Voltage = 3.3 V

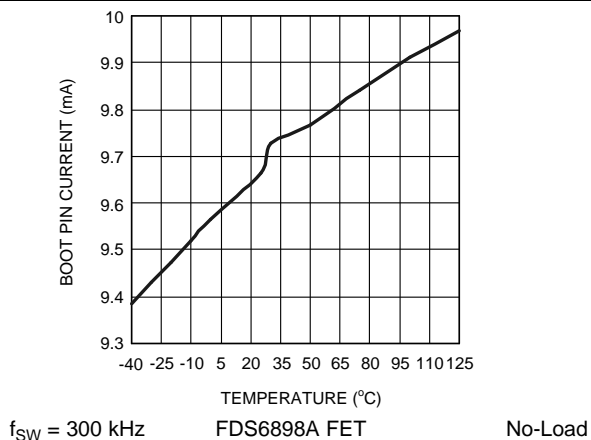
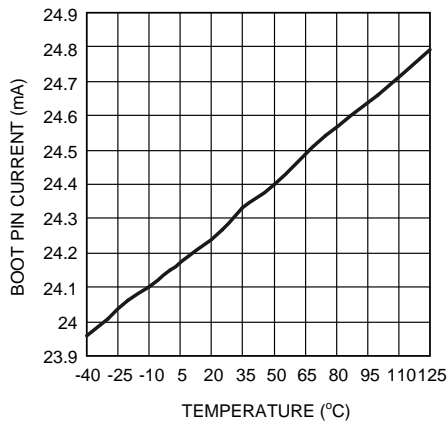

Figure 6. BOOT Pin Current vs Temperature for BOOT Voltage = 5 V

Typical Characteristics (continued)



$f_{SW} = 300 \text{ kHz}$ FDS6898A FET No-Load

Figure 7. BOOT Pin Current vs Temperature for BOOT Voltage = 12 V

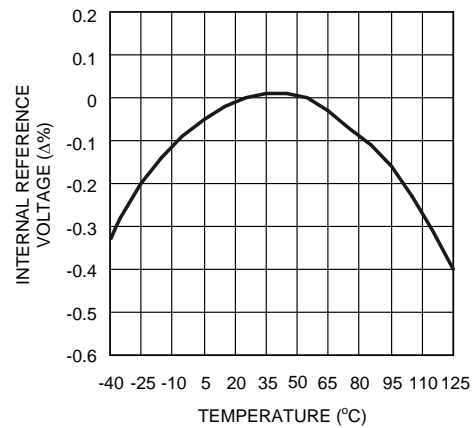

Figure 8. Internal Reference Voltage vs Temperature

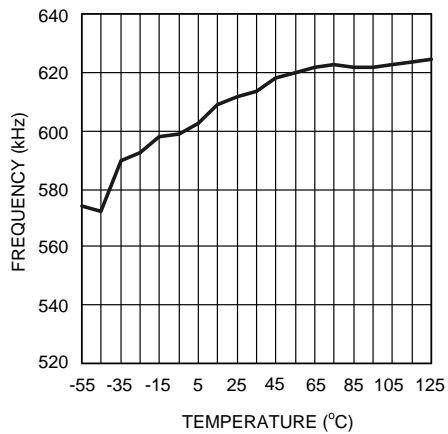

Figure 9. Frequency vs Temperature

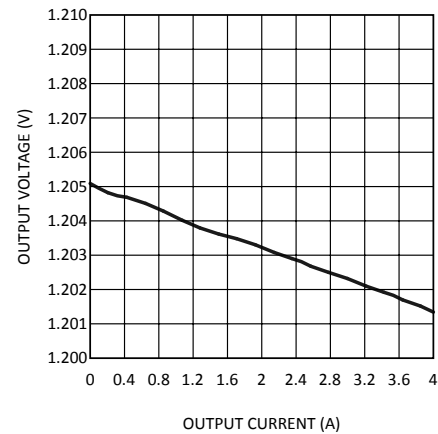
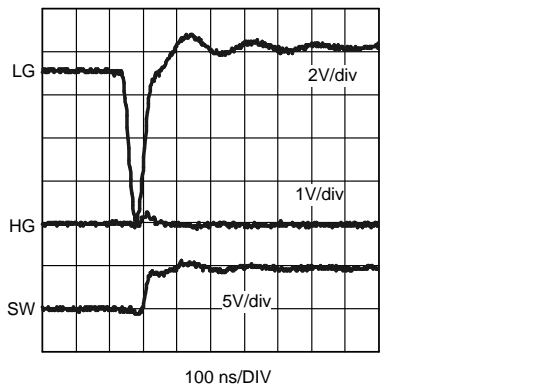
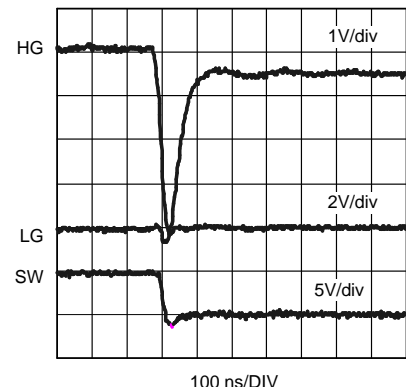

Figure 10. Output Voltage vs Output Current



$V_{CC} = 3.3 \text{ V}$ $V_{IN} = 5 \text{ V}$ $V_{OUT} = 1.2 \text{ V}$
 $I_{OUT} = 4 \text{ A}$ $C_{SS} = 12 \text{ nF}$ $f_{SW} = 300 \text{ kHz}$

Figure 11. Switch Waveforms (HG Rising)



$V_{CC} = 3.3 \text{ V}$ $V_{IN} = 5 \text{ V}$ $V_{OUT} = 1.2 \text{ V}$
 $I_{OUT} = 4 \text{ A}$ $C_{SS} = 12 \text{ nF}$ $f_{SW} = 300 \text{ kHz}$

Figure 12. Switch Waveforms (HG Falling)

Typical Characteristics (continued)

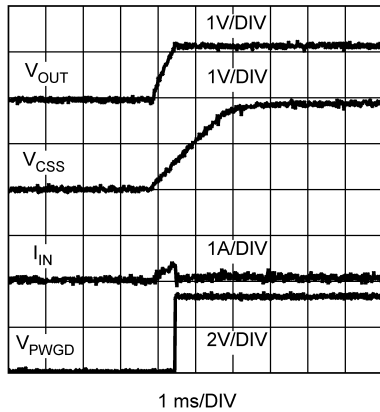

$V_{CC} = 3.3\text{ V}$ $V_{IN} = 5\text{ V}$ $V_{OUT} = 1.2\text{ V}$
 $C_{SS} = 12\text{ nF}$ $f_{SW} = 300\text{ kHz}$

Figure 13. Start-Up (No-Load)

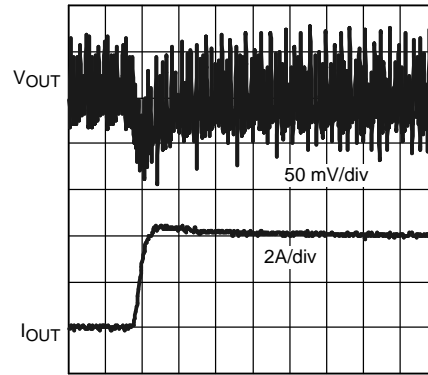

$I_{OUT} = 0\text{ A to }4\text{ A}$ $V_{CC} = 3.3\text{ V}$ $V_{IN} = 5\text{ V}$
 $V_{OUT} = 1.2\text{ V}$ $C_{SS} = 12\text{ nF}$ $f_{SW} = 300\text{ kHz}$

Figure 14. Load Transient Response

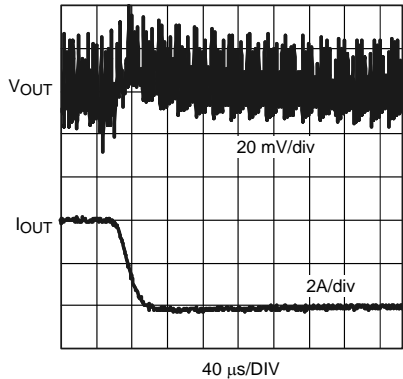

$I_{OUT} = 4\text{ A to }0\text{ A}$ $V_{CC} = 3.3\text{ V}$ $V_{IN} = 5\text{ V}$
 $V_{OUT} = 1.2\text{ V}$ $C_{SS} = 12\text{ nF}$ $f_{SW} = 300\text{ kHz}$

Figure 15. Load Transient Response

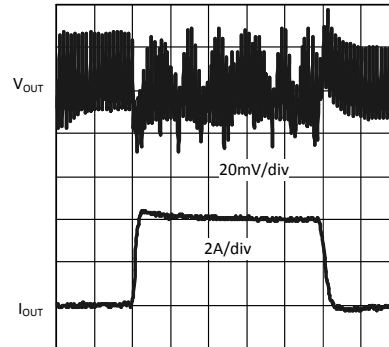

$V_{CC} = 3.3\text{ V}$ $V_{IN} = 5\text{ V}$ $V_{OUT} = 1.2\text{ V}$
 $C_{SS} = 12\text{ nF}$ $f_{SW} = 300\text{ kHz}$

Figure 16. Load Transient Response

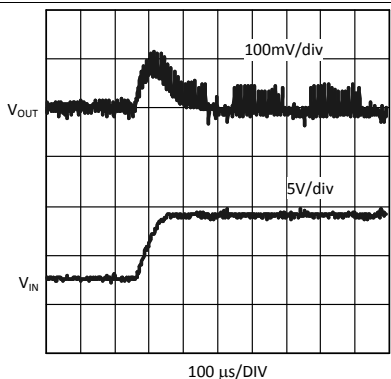

$V_{IN} = 3\text{ V to }9\text{ V}$ $V_{CC} = 3.3\text{ V}$ $V_{OUT} = 1.2\text{ V}$
 Line (), $I_{OUT} = 2\text{ A}$ $f_{SW} = 300\text{ kHz}$

Figure 17. Line Transient Response

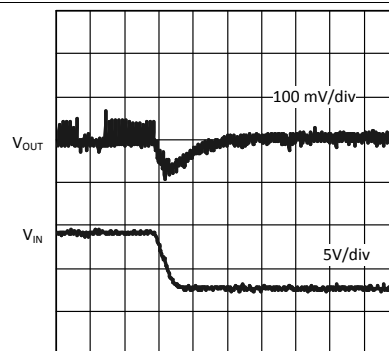

$V_{IN} = 9\text{ V to }3\text{ V}$ $V_{CC} = 3.3\text{ V}$ $V_{OUT} = 1.2\text{ V}$
 $I_{OUT} = 2\text{ A}$ $f_{SW} = 300\text{ kHz}$

Figure 18. Transient Response

7 Detailed Description

7.1 Overview

The LM2743 is a voltage-mode, high-speed synchronous buck regulator with a PWM control scheme. It has output shutdown (\overline{SD}), input under-voltage lock-out (UVLO) mode and power good (PWGD) flag (based on over-voltage and under-voltage detection). The over-voltage and under-voltage signals are logically OR'ed to drive the power good signal and provide a logic signal to the system if the output voltage goes out of regulation. Current limit is achieved by sensing the voltage V_{DS} across the low-side MOSFET.

7.2 Functional Block Diagram

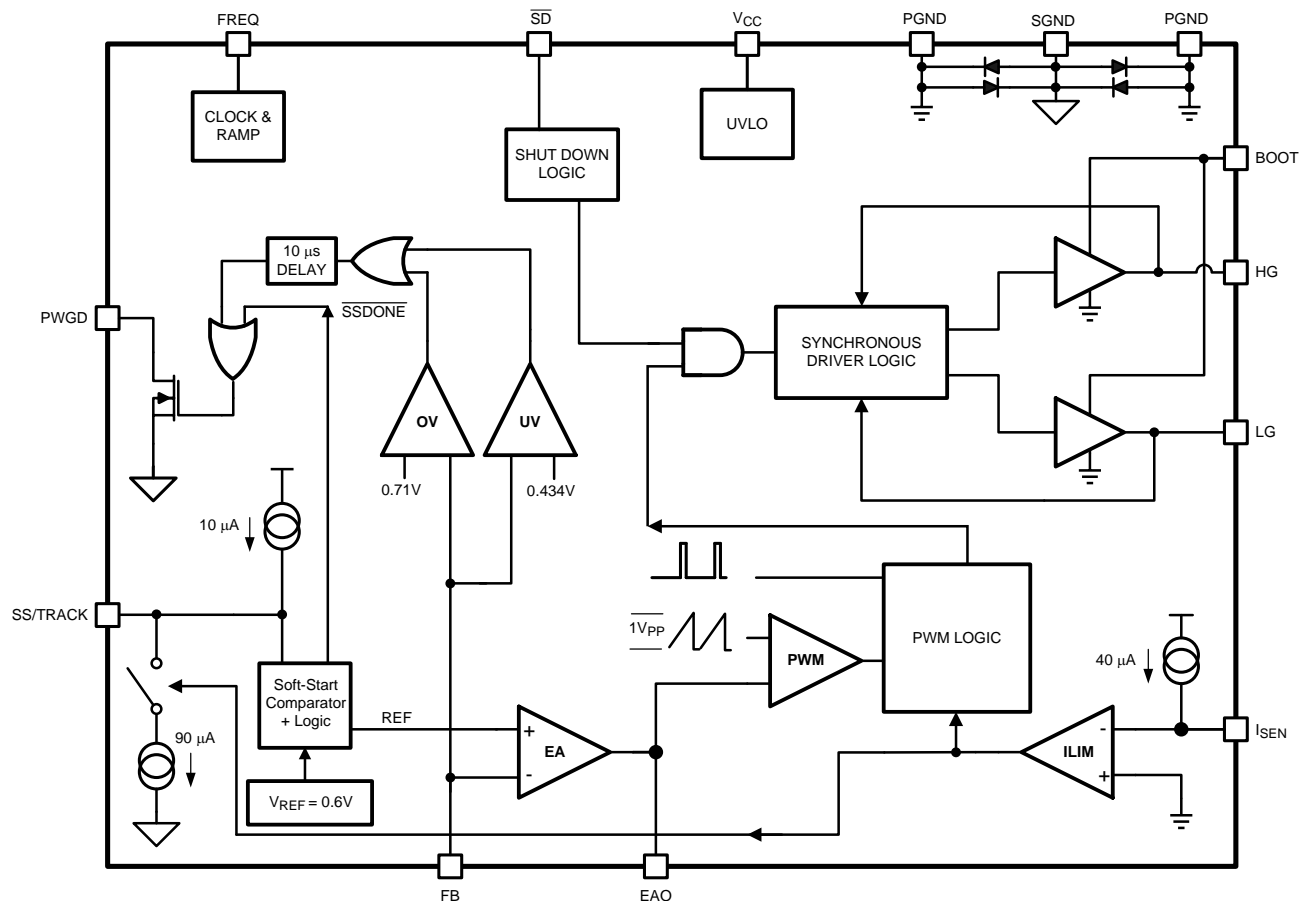

7.3 Feature Description

7.3.1 Start Up and Soft-Start

When V_{CC} exceeds 2.76V and the shutdown pin (\overline{SD}) sees a logic high, the soft-start period begins. Then an internal, fixed 10 μ A source begins charging the soft-start capacitor. During soft-start the voltage on the soft-start capacitor C_{SS} is connected internally to the non-inverting input of the error amplifier. The soft-start period lasts until the voltage on the soft-start capacitor exceeds the LM2743 reference voltage of 0.6V. At this point the reference voltage takes over at the non-inverting error amplifier input. The capacitance of C_{SS} determines the length of the soft-start period, and can be approximated by:

$$C_{SS} = \frac{t_{SS}}{60}$$

where

Feature Description (continued)

- C_{SS} is in μF and t_{SS} is in ms (1)

During soft start the Power Good flag is forced low and it is released when the FB pin voltage reaches 70% of 0.6V. At this point the chip enters normal operation mode, and the output overvoltage and undervoltage monitoring starts.

7.3.2 Normal Operation

While in normal operation mode, the LM2743 regulates the output voltage by controlling the duty cycle of the high side and low side MOSFETs (see [Typical Application Diagram](#)). The equation governing output voltage is:

$$V_{OUT} = \frac{R_{FB1} + R_{FB2}}{R_{FB1}} V_{FB}$$

$$(V_{FB} = 0.6\text{V}) \quad (2)$$

The PWM frequency is adjustable between 50 kHz and 1 MHz and is set by an external resistor, R_{FADJ} , between the FREQ pin and ground. The resistance needed for a desired frequency is approximately:

$$R_{FADJ} = -5.93 + 3.06 \frac{10^7}{f_{SW}} + 0.24 \frac{10^{12}}{(f_{SW})^2}$$
(3)

Where f_{SW} is in Hz and R_{FADJ} is in $\text{k}\Omega$.

7.3.3 Tracking a Voltage Level

The LM2743 can track the output of a master power supply during soft-start by connecting a resistor divider to the SS/TRACK pin. In this way, the output voltage slew rate of the LM2743 will be controlled by the master supply for loads that require precise sequencing. When the tracking function is used no soft-start capacitor should be connected to the SS/TRACK pin. Otherwise, a C_{SS} value of at least 1 nF between the soft-start pin and ground should be used.

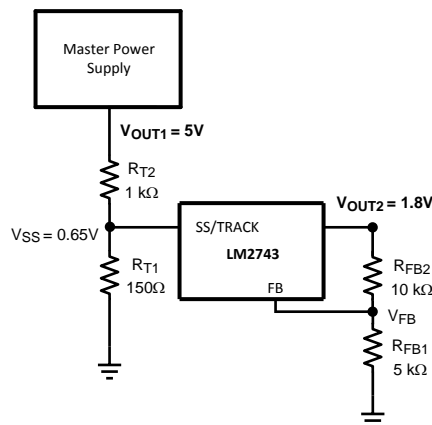

Figure 19. Tracking Circuit

One way to use the tracking feature is to design the tracking resistor divider so that the master supply's output voltage (V_{OUT1}) and the LM2743's output voltage (represented symbolically in [Figure 19](#) as V_{OUT2} , that is, without explicitly showing the power components) both rise together and reach their target values at the same time. For this case, the equation governing the values of the tracking divider resistors R_{T1} and R_{T2} is:

$$0.65 = V_{OUT1} \frac{R_{T1}}{R_{T1} + R_{T2}}$$
(4)

Feature Description (continued)

The current through R_{T1} should be about 3 mA to 4 mA for precise tracking. The final voltage of the SS/TRACK pin should be set higher than the feedback voltage of 0.6 V (say about 0.65 V as in the above equation). If the master supply voltage was 5 V and the LM2743 output voltage was 1.8 V, for example, then the value of R_{T1} needed to give the two supplies identical soft-start times would be 150 Ω . A timing diagram for the equal soft-start time case is shown in [Figure 20](#).

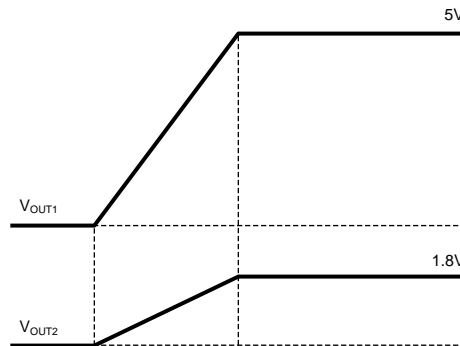

Figure 20. Tracking with Equal Soft-Start Time

7.3.4 Tracking Voltage Slew Rate

The tracking feature can alternatively be used not to make both rails reach regulation at the same time but rather to have similar rise rates (in terms of output dV/dt). This method ensures that the output voltage of the LM2743 always reaches regulation before the output voltage of the master supply. Because the output of the master supply is divided down, in order to track properly the output voltage of the LM2743 must be lower than the voltage of the master supply. In this case, the tracking resistors can be determined based on the following equation:

$$V_{OUT2} = V_{OUT1} \frac{R_{T1}}{R_{T1} + R_{T2}} \quad (5)$$

For the example case of $V_{OUT1} = 5$ V and $V_{OUT2} = 1.8$ V, with R_{T1} set to 150 Ω as before, R_{T2} is calculated from the above equation to be 265 Ω . A timing diagram for the case of equal slew rates is shown in [Figure 21](#).

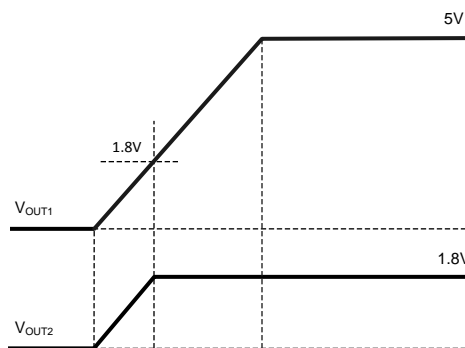

Figure 21. Tracking with Equal Slew Rates

7.3.5 Sequencing

The start up/soft-start of the LM2743 can be delayed for the purpose of sequencing by connecting a resistor divider from the output of a master power supply to the \overline{SD} pin, as shown in [Figure 22](#).

Feature Description (continued)

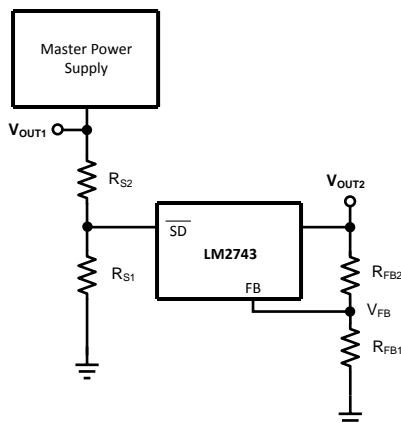

Figure 22. Sequencing Circuit

A desired delay time t_{DELAY} between the startup of the master supply output voltage and the LM2743 output voltage can be set based on the \overline{SD} pin low-to-high threshold V_{SD-IH} and the slew rate of the voltage at the \overline{SD} pin, SR_{SD} :

$$t_{DELAY} = V_{SD-IH} / SR_{SD} \tag{6}$$

Note again, that in Figure 22, the output voltage of the LM2743 has been represented symbolically as V_{OUT2} , without explicitly showing the power components.

V_{SD-IH} is typically 1.08V and SR_{SD} is the slew rate of the \overline{SD} pin voltage. The values of the sequencing divider resistors R_{S1} and R_{S2} set the SR_{SD} based on the master supply output voltage slew rate, SR_{OUT1} , using the following equation:

$$SR_{SD} = SR_{OUT1} \frac{R_{S1}}{R_{S1} + R_{S2}} \tag{7}$$

For example, if the master supply output voltage slew rate was 1V/ms and the desired delay time between the startup of the master supply and LM2743 output voltage was 5ms, then the desired \overline{SD} pin slew rate would be $(1.08V/5 \text{ ms}) = 0.216 \text{ V/ms}$. Due to the internal impedance of the \overline{SD} pin, the maximum recommended value for R_{S2} is 1 k Ω . To achieve the desired slew rate, R_{S1} would then be 274 Ω . A timing diagram for this example is shown in Figure 23.

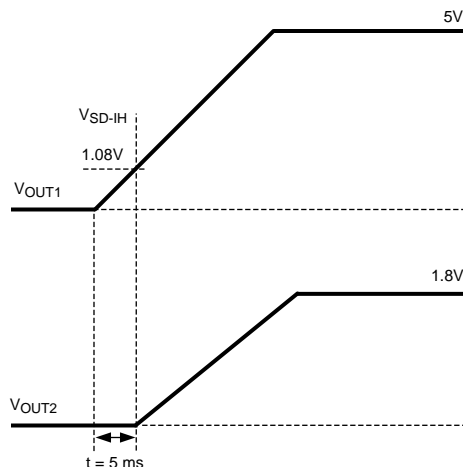

Figure 23. Delay for Sequencing

Feature Description (continued)

7.3.6 \overline{SD} Pin Impedance

When connecting a resistor divider to the \overline{SD} pin of the LM2743 some care has to be taken. Once the \overline{SD} voltage goes above V_{SD-IH} , a 17- μ A pull-up current is activated as shown in Figure 24. This current is used to create the internal hysteresis (≈ 170 mV); however, high external impedances will affect the \overline{SD} pin logic thresholds as well. The external impedance used for the sequencing divider network should preferably be a small fraction of the impedance of the \overline{SD} pin for good performance (around 1 k Ω).

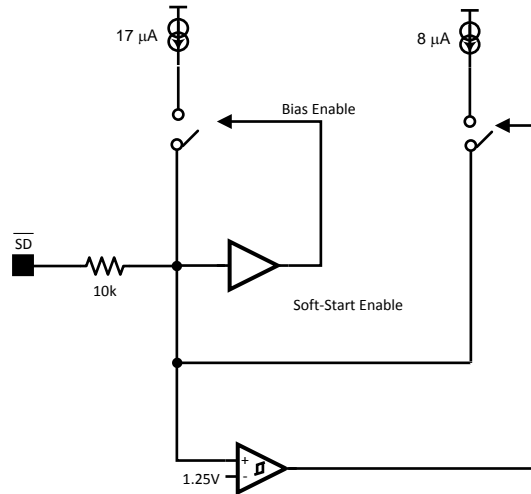

Figure 24. \overline{SD} Pin Logic

7.3.7 MOSFET Gate Drivers

The LM2743 has two gate drivers designed for driving N-channel MOSFETs in a synchronous mode. Note that unlike most other synchronous controllers, the bootstrap capacitor of the LM2743 provides power not only to the driver of the upper MOSFET, but the lower MOSFET driver too (both drivers are ground referenced, i.e. no floating driver). To fully turn the top MOSFET on, the BOOT voltage must be at least one gate threshold greater than V_{IN} when the high-side drive goes high. This bootstrap voltage is usually supplied from a local charge pump structure. But looking at the *Typical Application* schematic, this also means that the difference voltage $V_{CC} - V_{D1}$, which is the voltage the bootstrap capacitor charges up to, must be always greater than the maximum tolerance limit of the threshold voltage of the upper MOSFET. Here V_{D1} is the forward voltage drop across the bootstrap diode D1. This therefore may place restrictions on the minimum input voltage and/or type of MOSFET used.

The most basic charge bootstrap pump circuit can be built using one Schottky diode and a small capacitor, as shown in Figure 25. The capacitor C_{BOOT} serves to maintain enough voltage between the top MOSFET gate and source to control the device even when the top MOSFET is on and its source has risen up to the input voltage level. The charge pump circuitry is fed from V_{CC} , which can operate over a range from 3.0V to 6.0V. Using this basic method the voltage applied to the gates of both high-side and low-side MOSFETs is $V_{CC} - V_D$. This method works well when V_{CC} is $5 V \pm 10\%$, because the gate drives will get at least 4.0V of drive voltage during the worst case of $V_{CC-MIN} = 4.5 V$ and $V_{D-MAX} = 0.5 V$. Logic level MOSFETs generally specify their on-resistance at $V_{GS} = 4.5 V$. When $V_{CC} = 3.3 V \pm 10\%$, the gate drive at worst case could go as low as 2.5 V. Logic level MOSFETs are not specified to turn on, or may have much higher on-resistance at 2.5 V. Sub-logic level MOSFETs, usually specified at $V_{GS} = 2.5 V$, will work, but are more expensive, and tend to have higher on-resistance. The circuit in Figure 25 works well for input voltages ranging from 1 V up to 16 V and $V_{CC} = 5 V \pm 10\%$, because the drive voltage depends only on V_{CC} .

Feature Description (continued)

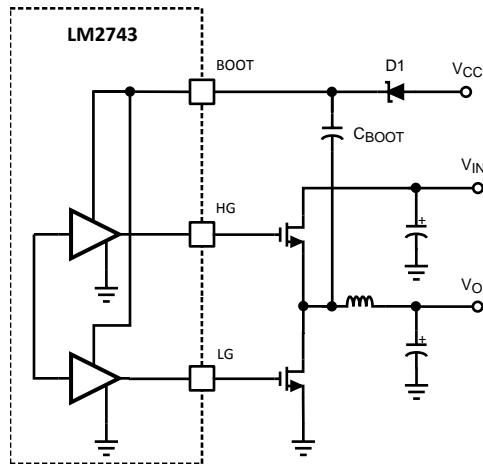

Figure 25. Basic Charge Pump (Bootstrap)

Note that the LM2743 can be paired with a low cost linear regulator like the LM78L05 to run from a single input rail between 6.0 and 14 V. The 5-V output of the linear regulator powers both the V_{CC} and the bootstrap circuit, providing efficient drive for logic level MOSFETs. An example of this circuit is shown in Figure 26.

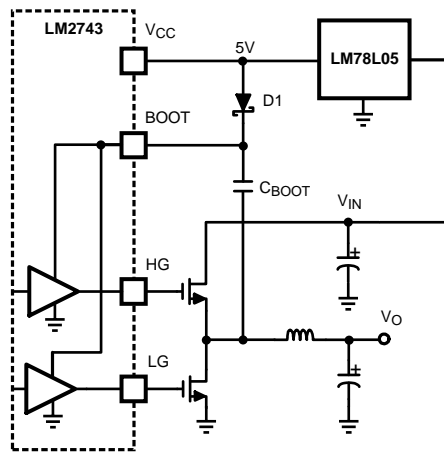

Figure 26. LM78L05 Feeding Basic Charge Pump

Figure 27 shows a second possibility for bootstrapping the MOSFET drives using a doubler. This circuit provides an equal voltage drive of $V_{CC} - 3V_D + V_{IN}$ to both the high-side and low-side MOSFET drives. This method should only be used in circuits that use 3.3 V for both V_{CC} and V_{IN} . Even with $V_{IN} = V_{CC} = 3.0$ V (10% lower tolerance on 3.3 V) and $V_D = 0.5$ V both high-side and low-side gates will have at least 4.5 V of drive. The power dissipation of the gate drive circuitry is directly proportional to gate drive voltage, hence the thermal limits of the LM2743 IC will quickly be reached if this circuit is used with V_{CC} or V_{IN} voltages over 5V.

Feature Description (continued)

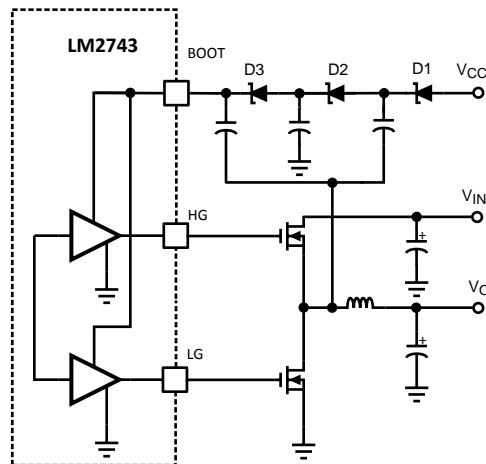

Figure 27. Charge Pump with Added Gate Drive

All the gate drive circuits shown in [Figure 25](#) through [Figure 27](#) typically use 100-nF ceramic capacitors in the bootstrap locations.

7.3.8 Power Good Signal

The open drain output on the Power Good pin needs a pull-up resistor to a low voltage source. The pull-up resistor should be chosen so that the current going into the Power Good pin is less than 1 mA. A 100-kΩ resistor is recommended for most applications.

The Power Good signal is an OR-gated flag which takes into account both output over-voltage and under-voltage conditions. If the feedback pin (FB) voltage is 18% above its nominal value ($118\% \times V_{FB} = 0.708\text{V}$) or falls 28% below that value ($72\% \times V_{FB} = 0.42\text{V}$) the Power Good flag goes low. The Power Good flag can be used to signal other circuits that the output voltage has fallen out of regulation, however the switching of the LM2743 continues regardless of the state of the Power Good signal. The Power Good flag will return to logic high whenever the feedback pin voltage is between 72% and 118% of 0.6V.

7.3.9 UVLO

The 2.76V turn-on threshold on V_{CC} has a built in hysteresis of about 300 mV. If V_{CC} drops below 2.42V, the chip enters UVLO mode. UVLO consists of turning off the top and bottom MOSFETS and remaining in that condition until V_{CC} rises above 2.76V. As with shutdown, the soft-start capacitor is discharged through an internal MOSFET, ensuring that the next start-up will be controlled by the soft-start circuitry.

7.3.10 Current Limit

Current limit is realized by sensing the voltage across the low-side MOSFET while it is on. The $R_{DS(ON)}$ of the MOSFET is a known value; hence the current through the MOSFET can be determined as:

$$V_{DS} = I_{OUT} \times R_{DS(ON)} \quad (8)$$

The current through the low-side MOSFET while it is on is also the falling portion of the inductor current. The current limit threshold is determined by an external resistor, R_{CS} , connected between the switching node and the I_{SEN} pin. A constant current of 40 μA is forced through R_{CS} , causing a fixed voltage drop. This fixed voltage is compared against V_{DS} and if the latter is higher, the current limit of the chip has been reached. To obtain a more accurate value for R_{CS} you must consider the operating values of $R_{DS(ON)}$ and I_{SEN-TH} at their operating temperatures in your application and the effect of slight parameter differences from part to part. R_{CS} can be found by using the following equation using the $R_{DS(ON)}$ value of the low side MOSFET at its expected hot temperature and the absolute minimum value expected over the full temperature range for the I_{SEN-TH} which is 25 μA :

$$R_{CS} = R_{DS(ON-HOT)} \times I_{LIM} / 40 \mu\text{A} \quad (9)$$

Feature Description (continued)

For example, a conservative 15-A current limit in a 10-A design with a minimum $R_{DS(ON)}$ of 10 m Ω would require a 6-k Ω resistor. To prevent the I_{SEN} pin from sinking too much current when the switch node goes above 9.5 V, the value of the current limit setting resistor R_{CS} should not be too low. The criterion is as follows,

$$R_{CS} \geq \frac{V_{IN} - 9.5V}{10 \text{ mA}} \quad (10)$$

where the 10 mA is the maximum current I_{SEN} pin is allowed to sink. For example if $V_{IN} = 13.2 \text{ V}$, the minimum value of R_{CS} is 370 Ω . Because current sensing is done across the low-side MOSFET, no minimum high-side on-time is necessary. The LM2743 enters current limit mode if the inductor current exceeds the current limit threshold at the point where the high-side MOSFET turns off and the low-side MOSFET turns on. (The point of peak inductor current, see [Figure 28](#)). Note that in normal operation mode the high-side MOSFET always turns on at the beginning of a clock cycle. In current limit mode, by contrast, the high-side MOSFET on-pulse is skipped. This causes inductor current to fall. Unlike a normal operation switching cycle, however, in a current limit mode switching cycle the high-side MOSFET will turn on as soon as inductor current has fallen to the current limit threshold. The LM2743 will continue to skip high-side MOSFET pulses until the inductor current peak is below the current limit threshold, at which point the system resumes normal operation.

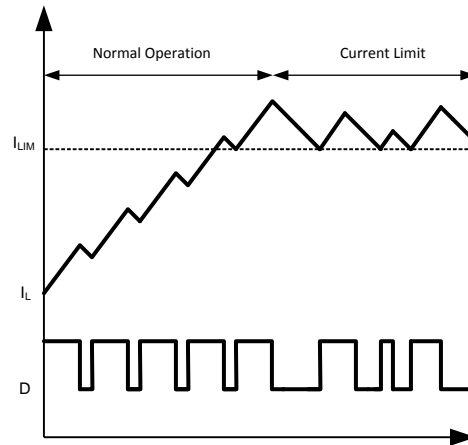

Figure 28. Current Limit Threshold

Unlike a high-side MOSFET current sensing scheme, which limits the peaks of inductor current, low-side current sensing is only allowed to limit the current during the converter off-time, when inductor current is falling. Therefore in a typical current limit plot the valleys are normally well defined, but the peaks are variable, according to the duty cycle. The PWM error amplifier and comparator control the off-pulse of the high-side MOSFET, even during current limit mode, meaning that peak inductor current can exceed the current limit threshold. Assuming that the output inductor does not saturate, the maximum peak inductor current during current limit mode can be calculated with the following equation:

$$I_{PK-CL} = I_{LIM} + (T_{SW} - 200 \text{ ns}) \frac{V_{IN} - V_O}{L} \quad (11)$$

Where T_{SW} is the inverse of switching frequency f_{SW} . The 200 ns term represents the minimum off-time of the duty cycle, which ensures enough time for correct operation of the current sensing circuitry.

Feature Description (continued)

In order to minimize the time period in which peak inductor current exceeds the current limit threshold, the IC also discharges the soft-start capacitor through a fixed 90- μ A sink. The output of the LM2743 internal error amplifier is limited by the voltage on the soft-start capacitor. Hence, discharging the soft-start capacitor reduces the maximum duty cycle D of the controller. During severe current limit this reduction in duty cycle will reduce the output voltage if the current limit conditions last for an extended time. Output inductor current will be reduced in turn to a flat level equal to the current limit threshold. The third benefit of the soft-start capacitor discharge is a smooth, controlled ramp of output voltage when the current limit condition is cleared.

7.3.11 Foldback Current Limit

In the case where extra protection is used to help an output short condition, a current foldback resistor (R_{CLF}) should be considered, see [Figure 29](#). First select the percentage of current limit foldback (P_{LIM}):

$$P_{LIM} = I_{LIM} \times P \quad (12)$$

where P is a ratio between 0 and 1.

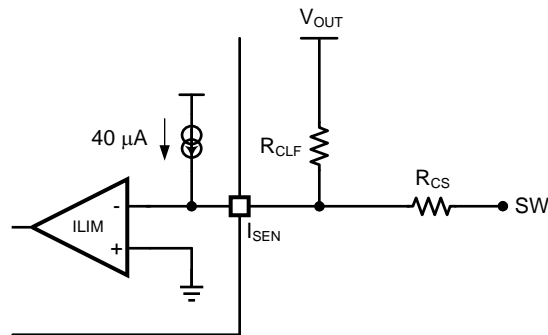

Figure 29. Foldback Current Limit Circuit

Obtain the R_{CS} with the following equation:

$$\frac{P_{LIM} \times R_{DS(ON)}}{I_{SEN}} = R_{CS} \quad (13)$$

where $I_{SEN} = 40 \mu\text{A}$. If the switch node goes above 9.5 V the following criterion must be satisfied:

$$R_{CS} \geq \frac{V_{IN} - 9.5\text{V}}{10 \text{ mA}} \quad (14)$$

The equation for calculating the foldback resistance value is:

$$R_{CLF} = \frac{R_{CS} \times V_{OUT}}{(I_{LIM} \times R_{DS(ON)}) - (I_{SEN} \times R_{CS})} \quad (15)$$

7.4 Device Functional Modes

7.4.1 Shutdown

If the shutdown pin is pulled low, (below 0.8 V) the LM2743 enters shutdown mode, and discharges the soft-start capacitor through a MOSFET switch. The high and low-side MOSFETs are turned off. The LM2743 remains in this state as long as V_{SD} sees a logic low (see the [Electrical Characteristics](#) table). To assure proper IC start-up the shutdown pin should not be left floating. For normal operation this pin should be connected directly to V_{CC} or to another voltage between 1.3 V to V_{CC} (see the [Electrical Characteristics](#) table).

8 Application and Implementation

NOTE

Information in the following applications sections is not part of the TI component specification, and TI does not warrant its accuracy or completeness. TI's customers are responsible for determining suitability of components for their purposes. Customers should validate and test their design implementation to confirm system functionality.

8.1 Application Information

The LM2743 is a voltage-mode, high-speed synchronous buck regulator with a PWM control scheme. It is designed for use in set-top boxes, thin clients, DSL/Cable modems, and other applications that require high-efficiency buck converters. Use the following design procedure to select component values for the LM2743 device. Use the WEBENCH to generate a complete design (see [Custom Design With WEBENCH® Tools](#)).

8.2 Typical Applications

8.2.1 Synchronous Buck Converter Typical Application using LM2743

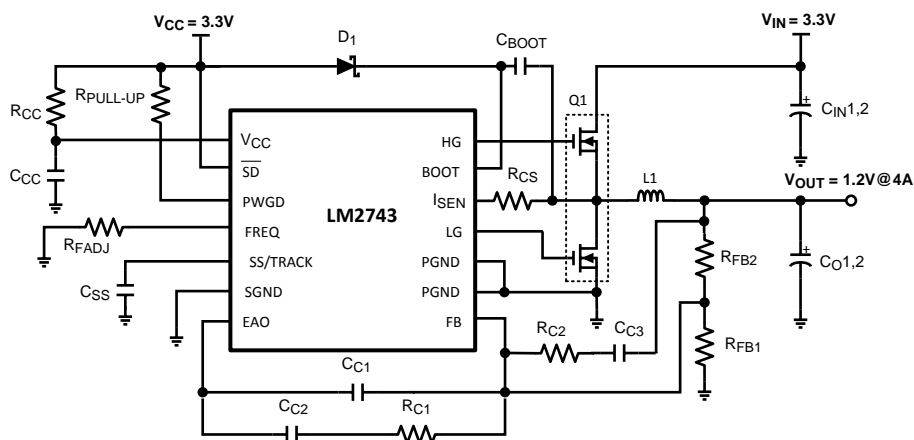

Figure 30. 3.3 V to 1.2 V at 4 A, $f_{SW} = 300$ kHz

8.2.1.1 Design Requirements

The following section provides a step-by-step design guide of a voltage-mode synchronous buck converter using the LM2743. This design converts 3.3 V (V_{IN}) to 1.2 V (V_{OUT}) at a maximum load of 4 A, with an efficiency of 89% and a switching frequency of 300 kHz. The same procedures can be followed to create many other designs with varying input voltages, output voltages, and load currents.

8.2.1.2 Detailed Design Procedure

8.2.1.2.1 Custom Design With WEBENCH® Tools

[Click here](#) to create a custom design using the LM2743 device with the WEBENCH® Power Designer.

1. Start by entering the input voltage (V_{IN}), output voltage (V_{OUT}), and output current (I_{OUT}) requirements.
2. Optimize the design for key parameters such as efficiency, footprint, and cost using the optimizer dial.
3. Compare the generated design with other possible solutions from Texas Instruments.

The WEBENCH Power Designer provides a customized schematic along with a list of materials with real-time pricing and component availability.

In most cases, these actions are available:

- Run electrical simulations to see important waveforms and circuit performance
- Run thermal simulations to understand board thermal performance

Typical Applications (continued)

- Export customized schematic and layout into popular CAD formats
- Print PDF reports for the design, and share the design with colleagues

Get more information about WEBENCH tools at www.ti.com/WEBENCH.

8.2.1.2.2 Duty Cycle Calculation

The complete duty cycle for a buck converter is defined with [Equation 16](#):

$$D = \frac{V_{OUT} + V_{SWL}}{V_{IN} - V_{SWH} + V_{SWL}} \quad (16)$$

where V_{SWL} and V_{SWH} are the respective forward voltage drops that develop across the low side and high side MOSFETs. Assuming the inductor ripple current is 20% to 30% of the output current, therefore:

$$V_{SWL} = I_{OUT} \times R_{DS(ON)LOW} \text{ (Low-Side MOSFET)} \quad (17)$$

$$V_{SWH} = I_{OUT} \times R_{DS(ON)HIGH} \text{ (High-Side MOSFET)} \quad (18)$$

To calculate the maximum duty cycle use the estimated 'hot' $R_{DS(on)}$ value of the MOSFETs, the minimum input voltage, and maximum load. As shown in [Figure 31](#), the worst case maximum duty cycles of the LM2743 occurs at 125°C junction temperature vs V_{CC} (IC control section voltage). Ensure that the operating duty cycle is below the curve in [Figure 31](#), if this condition is not satisfied, the system will be unable to develop the required duty cycle to derive the necessary system power and so the output voltage will fall out of regulation.

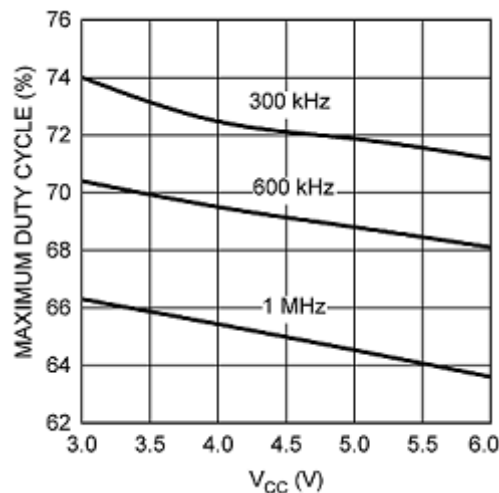

Figure 31. Maximum Duty Cycle vs V_{CC}
 $T_J = 125^\circ\text{C}$

8.2.1.2.3 Input Capacitor

The input capacitors in a Buck converter are subjected to high stress due to the input current trapezoidal waveform. Input capacitors are selected for their ripple current capability and their ability to withstand the heat generated since that ripple current passes through their ESR. Input rms ripple current is approximately:

$$I_{RMS_RIP} = I_{OUT} \times \sqrt{D(1 - D)} \quad (19)$$

The power dissipated by each input capacitor is:

$$P_{CAP} = \frac{(I_{RMS_RIP})^2 \times ESR}{n^2} \quad (20)$$

Typical Applications (continued)

where n is the number of capacitors, and ESR is the equivalent series resistance of each capacitor. The equation above indicates that power loss in each capacitor decreases rapidly as the number of input capacitors increases. The worst-case ripple for a Buck converter occurs during full load and when the duty cycle (D) is 0.5. For this 3.3V to 1.2V design the duty cycle is 0.364. For a 4A maximum load the ripple current is 1.92A.

8.2.1.2.4 Output Inductor

The output inductor forms the first half of the power stage in a Buck converter. It is responsible for smoothing the square wave created by the switching action and for controlling the output current ripple (ΔI_{OUT}). The inductance is chosen by selecting between tradeoffs in efficiency and response time. The smaller the output inductor, the more quickly the converter can respond to transients in the load current. However, as shown in the efficiency calculations, a smaller inductor requires a higher switching frequency to maintain the same level of output current ripple. An increase in frequency can mean increasing loss in the MOSFETs due to the charging and discharging of the gates. Generally the switching frequency is chosen so that conduction loss outweighs switching loss. The equation for output inductor selection is:

$$L = \frac{V_{IN} - V_{OUT}}{\Delta I_{OUT} \times f_{SW}} \times D \quad (21)$$

$$L = \frac{3.3V - 1.2V}{0.4 \times 4A \times 300 \text{ kHz}} \times \frac{1.2V}{3.3V} \quad (22)$$

$$L = 1.6 \mu\text{H} \quad (23)$$

Here we have plugged in the values for output current ripple, input voltage, output voltage, switching frequency, and assumed a 40% peak-to-peak output current ripple. This yields an inductance of 1.6 μH . The output inductor must be rated to handle the peak current (also equal to the peak switch current), which is $(I_{OUT} + (0.5 \times \Delta I_{OUT})) = 4.8 \text{ A}$, for a 4 A design. The Coilcraft DO3316P-222P is 2.2 μH , is rated to 7.4-A peak, and has a direct current resistance (DCR) of 12 m Ω .

After selecting an output inductor, inductor current ripple should be re-calculated with the new inductance value, as this information is needed to select the output capacitor. Re-arranging the equation used to select inductance yields the following:

$$\Delta I_{OUT} = \frac{V_{IN(MAX)} - V_O}{f_{SW} \times L_{ACTUAL}} \times D \quad (24)$$

$V_{IN(MAX)}$ is assumed to be 10% above the steady state input voltage, or 3.6V. The actual current ripple will then be 1.2A. Peak inductor/switch current will be 4.6A.

8.2.1.2.5 Output Capacitor

The output capacitor forms the second half of the power stage of a Buck switching converter. It is used to control the output voltage ripple (ΔV_{OUT}) and to supply load current during fast load transients.

In this example the output current is 4 A and the expected type of capacitor is an aluminum electrolytic, as with the input capacitors. Other possibilities include ceramic, tantalum, and solid electrolyte capacitors, however the ceramic type often do not have the large capacitance needed to supply current for load transients, and tantalums tend to be more expensive than aluminum electrolytic. Aluminum capacitors tend to have very high capacitance and fairly low ESR, meaning that the ESR zero, which affects system stability, will be much lower than the switching frequency. The large capacitance means that at the switching frequency, the ESR is dominant, hence the type and number of output capacitors is selected on the basis of ESR. One simple formula to find the maximum ESR based on the desired output voltage ripple, ΔV_{OUT} and the designed output current ripple, ΔI_{OUT} , is:

$$ESR_{MAX} = \frac{\Delta V_{OUT}}{\Delta I_{OUT}} \quad (25)$$

Typical Applications (continued)

In this example, in order to maintain a 2% peak-to-peak output voltage ripple and a 40% peak-to-peak inductor current ripple, the required maximum ESR is 20 mΩ. The Sanyo 4SP560M electrolytic capacitor will give an equivalent ESR of 14 mΩ. The capacitance of 560 μF is enough to supply energy even to meet severe load transient demands.

8.2.1.2.6 MOSFETs

Selection of the power MOSFETs is governed by a tradeoff between cost, size, and efficiency. One method is to determine the maximum cost that can be endured, and then select the most efficient device that fits that price. Breaking down the losses in the high-side and low-side MOSFETs and then creating spreadsheets is one way to determine relative efficiencies between different MOSFETs. Good correlation between the prediction and the bench result is not specified, however. Single-channel buck regulators that use a controller IC and discrete MOSFETs tend to be most efficient for output currents of 2A to 10A.

Losses in the high-side MOSFET can be broken down into conduction loss, gate charging loss, and switching loss. Conduction loss, or I^2R loss, is approximately:

$$P_C = D ((I_O)^2 \times R_{DSON-HI} \times 1.3) \text{ (High-Side MOSFET)} \quad (26)$$

$$P_C = (1 - D) \times ((I_O)^2 \times R_{DSON-LO} \times 1.3) \text{ (Low-Side MOSFET)} \quad (27)$$

In the above equations, the factor 1.3 accounts for the increase in MOSFET R_{DSON} due to heating. Alternatively, the 1.3 can be ignored and the R_{DSON} of the MOSFET estimated using the **R_{DSON} Vs. Temperature** curves in the MOSFET datasheets.

Gate charging loss results from the current driving the gate capacitance of the power MOSFETs, and is approximated as:

$$P_{GC} = n \times (V_{DD}) \times Q_G \times f_{SW} \quad (28)$$

where 'n' is the number of MOSFETs (if multiple devices have been placed in parallel), V_{DD} is the driving voltage (see [MOSFET Gate Drivers](#) section) and Q_{GS} is the gate charge of the MOSFET. If different types of MOSFETs are used, the n term can be ignored and their gate charges simply summed to form a cumulative Q_G . Gate charge loss differs from conduction and switching losses in that the actual dissipation occurs in the LM2743, and not in the MOSFET itself.

Switching loss occurs during the brief transition period as the high-side MOSFET turns on and off, during which both current and voltage are present in the channel of the MOSFET. It can be approximated as:

$$P_{SW} = 0.5 \times V_{IN} \times I_O \times (t_r + t_f) \times f_{SW} \quad (29)$$

where t_r and t_f are the rise and fall times of the MOSFET. Switching loss occurs in the high-side MOSFET only.

For this example, the maximum drain-to-source voltage applied to either MOSFET is 3.6V. The maximum drive voltage at the gate of the high-side MOSFET is 3.1V, and the maximum drive voltage for the low-side MOSFET is 3.3V. Due to the low drive voltages in this example, a MOSFET that turns on fully with 3.1V of gate drive is needed. For designs of 5A and under, dual MOSFETs in SOIC-8 package provide a good trade-off between size, cost, and efficiency.

8.2.1.2.7 Support Components

C_{IN2} - A small value (0.1-μF to 1-μF) ceramic capacitor should be placed as close as possible to the drain of the high-side MOSFET and source of the low-side MOSFET (dual MOSFETs make this easy). This capacitor should be X5R type dielectric or better.

R_{CC} , C_{CC} - These are standard filter components designed to ensure smooth DC voltage for the chip supply. R_{CC} should be 1 Ω to 10 Ω. C_{CC} should 1 μF, X5R type or better.

C_{BOOT} - Bootstrap capacitor, typically 100 nF.

$R_{PULL-UP}$ – This is a standard pull-up resistor for the open-drain power good signal (PWGD). The recommended value is 10 kΩ connected to V_{CC} . If this feature is not necessary, the resistor can be omitted.

Typical Applications (continued)

D₁ - A small Schottky diode should be used for the bootstrap. It allows for a minimum drop for both high and low-side drivers. The MBR0520 or BAT54 work well in most designs.

R_{CS} - Resistor used to set the current limit. Since the design calls for a peak current magnitude (I_{OUT+} ($0.5 \times \Delta I_{OUT}$)) of 4.8 A, a safe setting would be 6A. (This is below the saturation current of the output inductor, which is 7 A.) Following the equation from the [Current Limit](#) section, a 1.3-k Ω resistor should be used.

R_{FADJ} - This resistor is used to set the switching frequency of the chip. The resistor value is calculated from equation in [Normal Operation](#) section. For 300-kHz operation, a 97.6-k Ω resistor should be used.

C_{SS} - The soft-start capacitor depends on the user requirements and is calculated based on the equation given in the section titled [Start Up and Soft-Start](#). Therefore, for a 700- μ s delay, a 12-nF capacitor is suitable.

8.2.1.2.8 Control Loop Compensation

The LM2743 uses voltage-mode ('VM') PWM control to correct changes in output voltage due to line and load transients. One of the attractive advantages of voltage mode control is its relative immunity to noise and layout. However VM requires careful small signal compensation of the control loop for achieving high bandwidth and good phase margin.

The control loop is comprised of two parts. The first is the power stage, which consists of the duty cycle modulator, output inductor, output capacitor, and load. The second part is the error amplifier, which for the LM2743 is a 9-MHz op-amp used in the classic inverting configuration. [Figure 32](#) shows the regulator and control loop components.

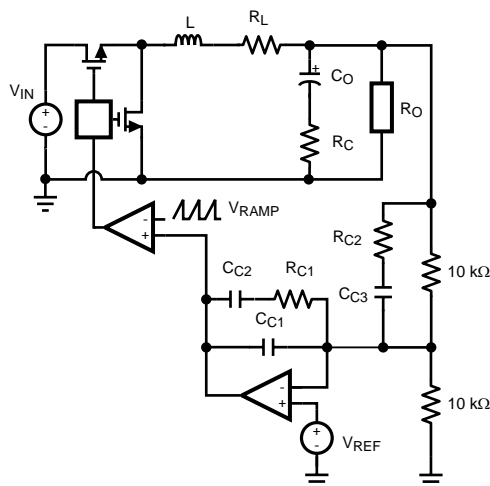

Figure 32. Power Stage and Error Amplifier

One popular method for selecting the compensation components is to create Bode plots of gain and phase for the power stage and error amplifier. Combined, they make the overall bandwidth and phase margin of the regulator easy to see. Software tools such as Excel, MathCAD, and Matlab are useful for showing how changes in compensation or the power stage affect system gain and phase.

The power stage modulator provides a DC gain A_{DC} that is equal to the input voltage divided by the peak-to-peak value of the PWM ramp. This ramp is 1.0V-P for the LM2743. The inductor and output capacitor create a double pole at frequency f_{DP} , and the capacitor ESR and capacitance create a single zero at frequency f_{ESR} . For this example, with $V_{IN} = 3.3$ V, these quantities are:

$$A_{DC} = \frac{V_{IN}}{V_{RAMP}} = \frac{3.3}{1.0} = 10.4 \text{ dB} \quad (30)$$

$$f_{DP} = \frac{1}{2\pi} \sqrt{\frac{R_O + R_L}{LC_O(R_O + ESR)}} = 4.5 \text{ kHz} \quad (31)$$

Typical Applications (continued)

$$f_{\text{ESR}} = \frac{1}{2\pi C_{\text{O}} \text{ESR}} = 20.3 \text{ kHz} \quad (32)$$

In the equation for f_{DP} , the variable R_{L} is the power stage resistance, and represents the inductor DCR plus the on resistance of the top power MOSFET. R_{O} is the output voltage divided by output current. The power stage transfer function G_{PS} is given by the following equation, and [Figure 34](#) shows Bode plots of the phase and gain in this example.

$$G_{\text{PS}} = \frac{V_{\text{IN}} \times R_{\text{O}}}{V_{\text{RAMP}}} \times \frac{sC_{\text{O}}R_{\text{C}} + 1}{a \times s^2 + b \times s + c}$$

where

- $a = LC_{\text{O}}(R_{\text{O}} + R_{\text{C}})$
 - $b = L + C_{\text{O}}(R_{\text{O}}R_{\text{L}} + R_{\text{O}}R_{\text{C}} + R_{\text{C}}R_{\text{L}})$
 - $c = R_{\text{O}} + R_{\text{L}}$
- (33)

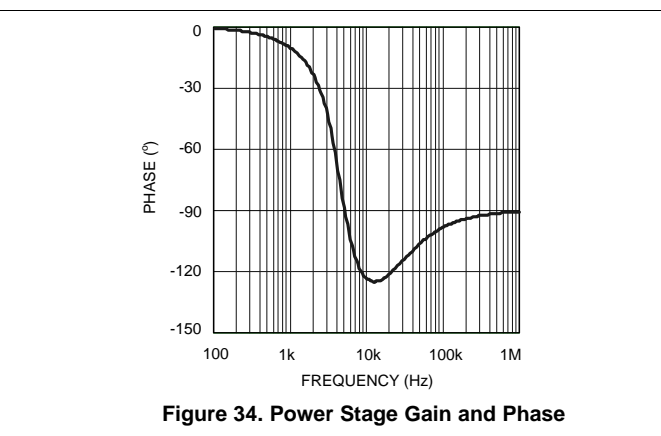
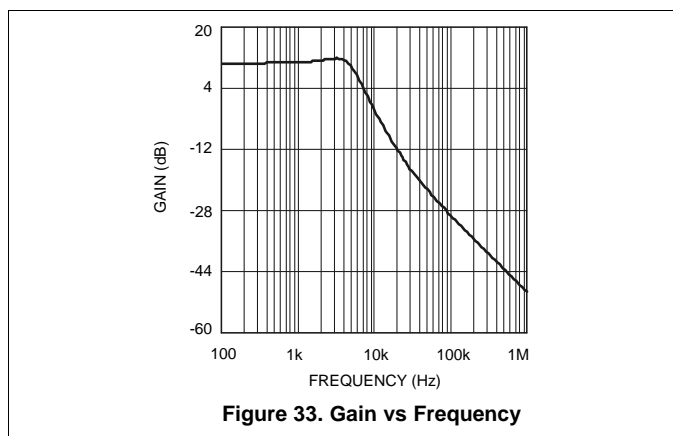

The double pole at 4.5 kHz causes the phase to drop to approximately -130° at around 10 kHz. The ESR zero, at 20.3 kHz, provides a $+90^\circ$ boost that prevents the phase from dropping to -180° . If this loop were left uncompensated, the bandwidth would be approximately 10 kHz and the phase margin 53° . In theory, the loop would be stable, but would suffer from poor DC regulation (due to the low DC gain) and would be slow to respond to load transients (due to the low bandwidth.) In practice, the loop could easily become unstable due to tolerances in the output inductor, capacitor, or changes in output current, or input voltage. Therefore, the loop is compensated using the error amplifier and a few passive components.

For this example, a Type III, or three-pole-two-zero approach gives optimal bandwidth and phase.

In most voltage mode compensation schemes, including Type III, a single pole is placed at the origin to boost DC gain as high as possible. Two zeroes f_{z1} and f_{z2} are placed at the double pole frequency to cancel the double pole phase lag. Then, a pole, f_{p1} is placed at the frequency of the ESR zero. A final pole f_{p2} is placed at one-half of the switching frequency. The gain of the error amplifier transfer function is selected to give the best bandwidth possible without violating the Nyquist stability criteria. In practice, a good crossover point is one-fifth of the switching frequency, or 60 kHz for this example. The generic equation for the error amplifier transfer function is:

$$G_{\text{EA}} = A_{\text{EA}} \times \frac{\left(\frac{s}{2\pi f_{z1}} + 1\right)\left(\frac{s}{2\pi f_{z2}} + 1\right)}{s\left(\frac{s}{2\pi f_{p1}} + 1\right)\left(\frac{s}{2\pi f_{p2}} + 1\right)} \quad (34)$$

Typical Applications (continued)

In this equation, the variable A_{EA} is a ratio of the values of the capacitance and resistance of the compensation components, arranged as shown in [Figure 32](#). A_{EA} is selected to provide the desired bandwidth. A starting value of 80,000 for A_{EA} should give a conservative bandwidth. Increasing the value will increase the bandwidth, but will also decrease phase margin. Designs with 45° to 60° are usually best because they represent a good trade-off between bandwidth and phase margin. In general, phase margin is lowest and gain highest (worst-case) for maximum input voltage and minimum output current. One method to select A_{EA} is to use an iterative process beginning with these worst-case conditions.

1. Increase A_{EA}
2. Check overall bandwidth and phase margin
3. Change V_{IN} to minimum and recheck overall bandwidth and phase margin
4. Change I_O to maximum and recheck overall bandwidth and phase margin

The process ends when the both bandwidth and the phase margin are sufficiently high. For this example input voltage can vary from 3.0 to 3.6 V and output current can vary from 0 to 4 A, and after a few iterations a moderate gain factor of 101 dB is used.

The error amplifier of the LM2743 has a unity-gain bandwidth of 9 MHz. In order to model the effect of this limitation, the open-loop gain can be calculated as:

$$OPG = \frac{2\pi \times 9 \text{ MHz}}{s} \quad (35)$$

The new error amplifier transfer function that takes into account unity-gain bandwidth is:

$$H_{EA} = \frac{G_{EA} \times OPG}{1 + G_{EA} + OPG} \quad (36)$$

The gain and phase of the error amplifier are shown in [Figure 36](#).

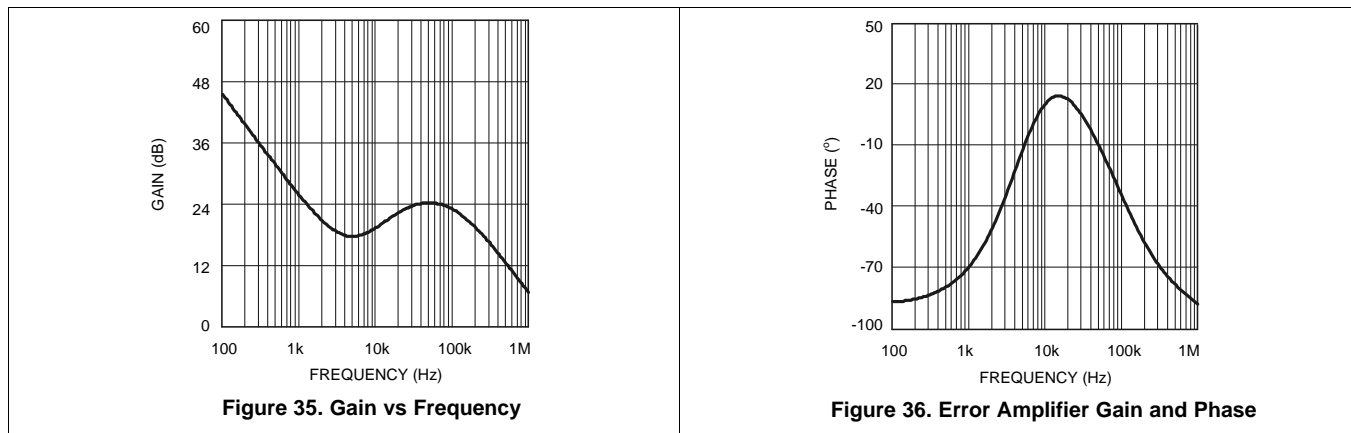

In VM regulators, the top feedback resistor R_{FB2} forms a part of the compensation. Setting R_{FB2} to 10 k Ω , $\pm 1\%$ usually gives values for the other compensation resistors and capacitors that fall within a reasonable range. (Capacitances > 1 pF, resistances < 1 M Ω) C_{C1} , C_{C2} , C_{C3} , R_{C1} , and R_{C2} are selected to provide the poles and zeroes at the desired frequencies, using the following equations:

$$C_{C1} = \frac{f_{Z1}}{A_{EA} \times 10,000 \times f_{P2}} = 27 \text{ pF} \quad (37)$$

$$C_{C2} = \frac{1}{A_{EA} \times 10,000} - C_{C1} = 882 \text{ pF} \quad (38)$$

Typical Applications (continued)

$$C_{C3} = \frac{1}{2\pi \times 10,000} \times \left(\frac{1}{f_{Z2}} - \frac{1}{f_{P1}} \right) = 2.73 \text{ nF} \quad (39)$$

$$R_{C1} = \frac{1}{2\pi \times C_{C2} \times f_{Z1}} = 39.8 \text{ k}\Omega \quad (40)$$

$$R_{C2} = \frac{1}{2\pi \times C_{C3} \times f_{P1}} = 2.55 \text{ k}\Omega \quad (41)$$

In practice, a good trade off between phase margin and bandwidth can be obtained by selecting the closest $\pm 10\%$ capacitor values above what are suggested for C_{C1} and C_{C2} , the closest $\pm 10\%$ capacitor value below the suggestion for C_{C3} , and the closest $\pm 1\%$ resistor values below the suggestions for R_{C1} , R_{C2} . Note that if the suggested value for R_{C2} is less than 100Ω , it should be replaced by a short circuit. Following this guideline, the compensation components will be:

$$C_{C1} = 27 \text{ pF } \pm 10\%$$

$$C_{C2} = 820 \text{ pF } \pm 10\%$$

$$C_{C3} = 2.7 \text{ nF } \pm 10\%$$

$$R_{C1} = 39.2 \text{ k}\Omega \pm 1\%$$

$$R_{C2} = 2.55 \text{ k}\Omega \pm 1\%$$

The transfer function of the compensation block can be derived by considering the compensation components as impedance blocks Z_F and Z_I around an inverting op-amp:

$$G_{EA-ACTUAL} = \frac{Z_F}{Z_I} \quad (42)$$

$$Z_F = \frac{\frac{1}{sC_{C1}} \times \left(10,000 + \frac{1}{sC_{C2}} \right)}{10,000 + \frac{1}{sC_{C1}} + \frac{1}{sC_{C2}}} \quad (43)$$

$$Z_I = \frac{R_{C1} \left(R_{C2} + \frac{1}{sC_{C3}} \right)}{R_{C1} + R_{C2} + \frac{1}{sC_{C3}}} \quad (44)$$

As with the generic equation, $G_{EA-ACTUAL}$ must be modified to take into account the limited bandwidth of the error amplifier. The result is:

$$H_{EA} = \frac{G_{EA-ACTUAL} \times OPG}{1 + G_{EA-ACTUAL} + OPG} \quad (45)$$

The total control loop transfer function H is equal to the power stage transfer function multiplied by the error amplifier transfer function.

$$H = G_{PS} \times H_{EA} \quad (46)$$

Typical Applications (continued)

The bandwidth and phase margin can be read graphically from Bode plots of H_{EA} are shown in [Figure 38](#).

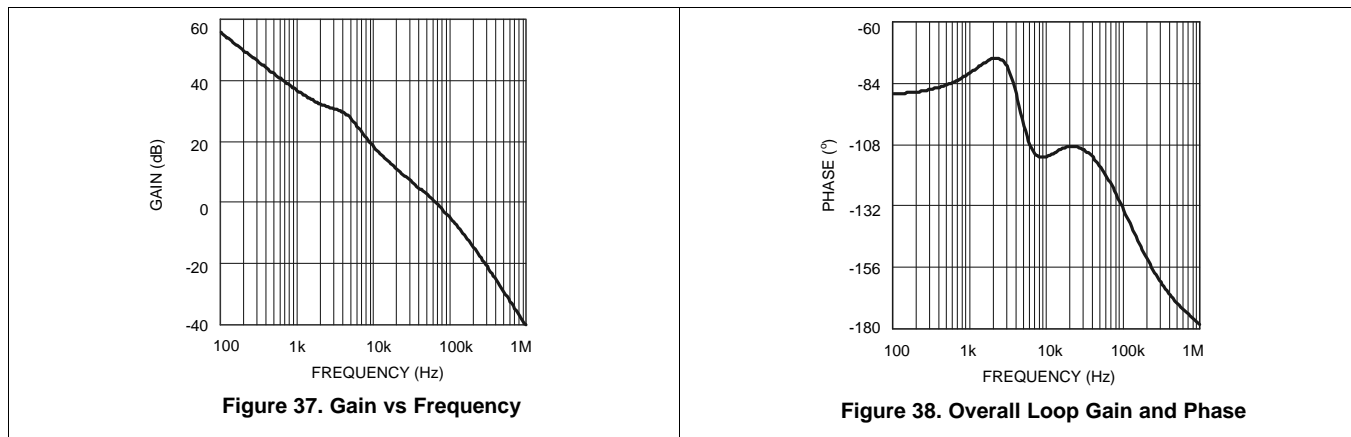

The bandwidth of this example circuit is 59 kHz, with a phase margin of 60°.

8.2.1.2.9 Efficiency Calculations

The following is a sample calculation.

A reasonable estimation of the efficiency of a switching buck controller can be obtained by adding together the Output Power (P_{OUT}) loss and the Total Power (P_{TOTAL}) loss:

$$\eta = \frac{P_{OUT}}{P_{OUT} + P_{TOTAL}} \times 100\% \quad (47)$$

The Output Power (P_{OUT}) for the [Figure 30](#) design is (1.2 V x 4 A) = 4.8 W. The Total Power (P_{TOTAL}), with an efficiency calculation to complement the design, is shown below.

The majority of the power losses are due to low and high side of MOSFET's losses. The losses in any MOSFET are group of switching (P_{SW}) and conduction losses(P_{CND}).

$$P_{FET} = P_{SW} + P_{CND} = 61.38 \text{ mW} + 270.42 \text{ mW} \quad (48)$$

$$P_{FET} = 331.8 \text{ mW} \quad (49)$$

The following equations show FET Switching Loss (P_{SW}).

$$P_{SW} = P_{SW(ON)} + P_{SW(OFF)} \quad (50)$$

$$P_{SW} = 0.5 \times V_{IN} \times I_{OUT} \times (t_r + t_f) \times f_{SW} \quad (51)$$

$$P_{SW} = 0.5 \times 3.3 \text{ V} \times 4 \text{ A} \times 300 \text{ kHz} \times 31 \text{ ns} \quad (52)$$

$$P_{SW} = 61.38 \text{ mW} \quad (53)$$

The FDS6898A has a typical turn-on rise time t_r and turn-off fall time t_f of 15 ns and 16 ns, respectively. The switching losses for this type of dual N-Channel MOSFETs are 0.061 W.

The following equations show FET Conduction Loss (P_{CND}).

$$P_{CND} = P_{CND1} + P_{CND2} \quad (54)$$

$$P_{CND1} = (I_{OUT})^2 \times R_{DS(ON)} \times k \times D \quad (55)$$

$$P_{CND2} = (I_{OUT})^2 \times R_{DS(ON)} \times k \times (1-D) \quad (56)$$

$R_{DS(ON)} = 13 \text{ m}\Omega$ and the factor is a constant value ($k = 1.3$) to account for the increasing $R_{DS(ON)}$ of a FET due to heating.

$$P_{CND1} = (4\text{A})^2 \times 13 \text{ m}\Omega \times 1.3 \times 0.364 \quad (57)$$

Typical Applications (continued)

$$P_{\text{CND2}} = (4\text{A})^2 \times 13 \text{ m}\Omega \times 1.3 \times (1 - 0.364) \quad (58)$$

$$P_{\text{CND}} = 98.42 \text{ mW} + 172 \text{ mW} = 270.42 \text{ mW} \quad (59)$$

There are few additional losses that are taken into account:

The following equations show IC Operating Loss (P_{IC}).

$$P_{\text{IC}} = I_{\text{Q-VCC}} \times V_{\text{CC}} \quad (60)$$

where $I_{\text{Q-VCC}}$ is the typical operating V_{CC} current

$$P_{\text{IC}} = 1.5 \text{ mA} \times 3.3\text{V} = 4.95 \text{ mW} \quad (61)$$

The following equations show FET Gate Charging Loss (P_{GATE}).

$$P_{\text{GATE}} = n \times V_{\text{CC}} \times Q_{\text{GS}} \times f_{\text{SW}} \quad (62)$$

$$P_{\text{GATE}} = 2 \times 3.3 \text{ V} \times 3 \text{ nC} \times 300 \text{ kHz} \quad (63)$$

$$P_{\text{GATE}} = 5.94 \text{ mW} \quad (64)$$

The value n is the total number of FETs used and Q_{GS} is the typical gate-source charge value, which is 3 nC. For the FDS6898A the gate charging loss is 5.94 mW.

The following equations show Input Capacitor Loss (P_{CAP}).

$$P_{\text{CAP}} = \frac{(I_{\text{RMS_RIP}})^2 \times \text{ESR}}{n^2}$$

where (65)

$$I_{\text{RMS_RIP}} = I_{\text{OUT}} \times \sqrt{D(1-D)} \quad (66)$$

Here n is the number of paralleled capacitors, ESR is the equivalent series resistance of each, and P_{CAP} is the dissipation in each. So for example if we use only one input capacitor of 24 m Ω .

$$P_{\text{CAP}} = \frac{(1.924\text{A})^2 \times 24 \text{ m}\Omega}{1^2} \quad (67)$$

$$P_{\text{CAP}} = 88.8 \text{ mW} \quad (68)$$

The following equation shows Output Inductor Loss (P_{IND}).

$$P_{\text{IND}} = I_{\text{OUT}}^2 \times \text{DCR} \quad (69)$$

where DCR is the DC resistance. Therefore, for example

$$P_{\text{IND}} = (4\text{A})^2 \times 11 \text{ m}\Omega \quad (70)$$

$$P_{\text{IND}} = 176 \text{ mW} \quad (71)$$

The following equations show Total System Efficiency.

$$P_{\text{TOTAL}} = P_{\text{FET}} + P_{\text{IC}} + P_{\text{GATE}} + P_{\text{CAP}} + P_{\text{IND}} \quad (72)$$

$$\eta = \frac{P_{\text{OUT}}}{P_{\text{OUT}} + P_{\text{TOTAL}}} \times 100\% \quad (73)$$

$$\eta = \frac{4.8\text{W}}{4.8\text{W} + 0.6\text{W}} = 89\% \quad (74)$$

Typical Applications (continued)

8.2.1.3 Application Curves

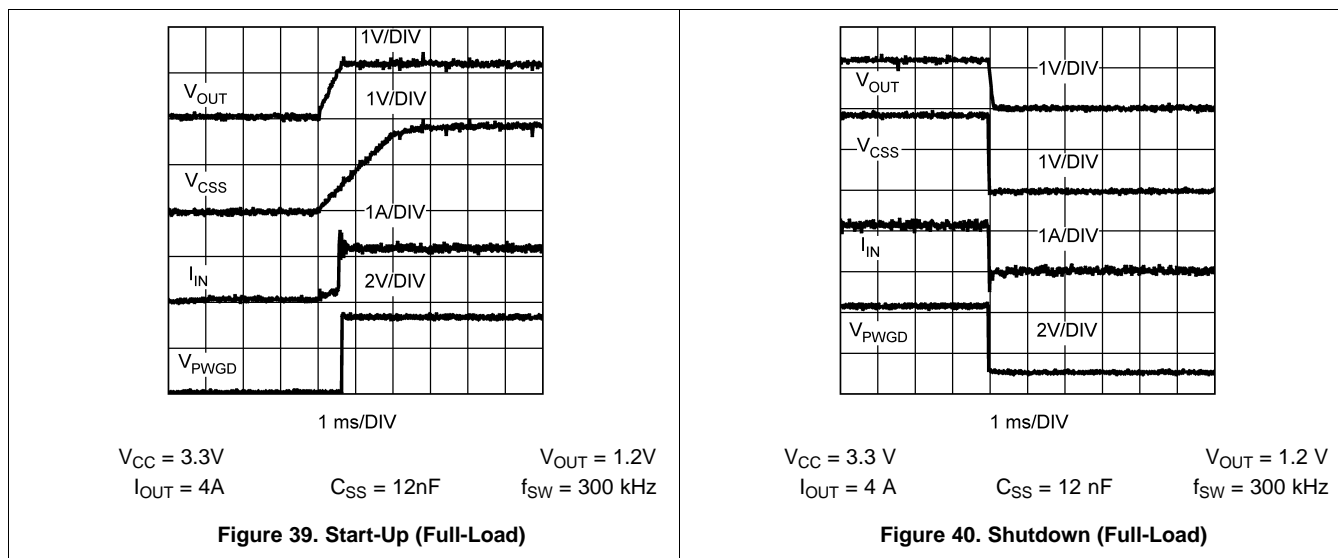

8.2.2 Example Circuit 1

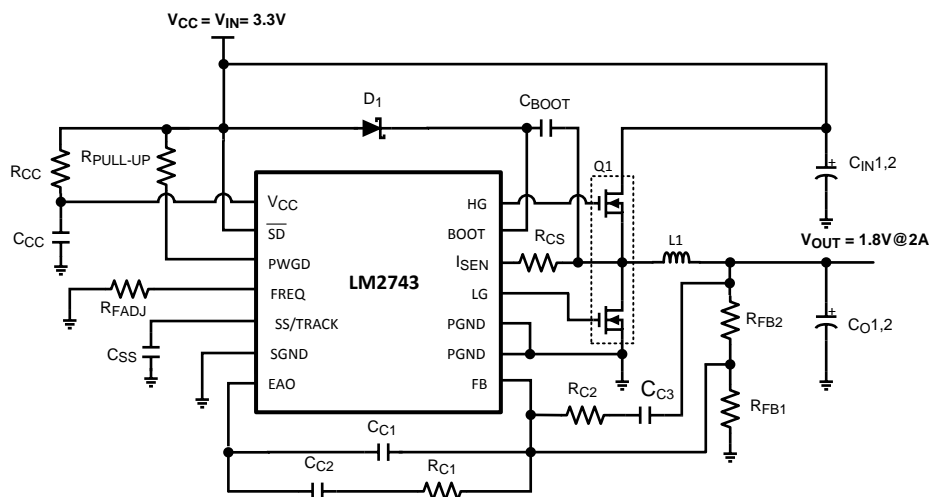

Figure 41. 3.3 V to 1.8 V at 2 A, $f_{SW} = 300\text{ kHz}$

8.2.2.1 Design Requirements

This design converts 3.3 V (V_{IN}) to 1.8 V (V_{OUT}) at a maximum load of 2 A, with a switching frequency of 300 kHz.

8.2.2.2 Detailed Design Procedure

Follow the detailed design procedure in [Detailed Design Procedure](#).

8.2.3.2 Detailed Design Procedure

Follow the detailed design procedure in [Detailed Design Procedure](#).

8.2.3.3 Bill of Materials

Table 2. Bill of Materials

PART	PART NUMBER	TYPE	PACKAGE	DESCRIPTION	VENDOR
U1	LM2743	Synchronous Controller	TSSOP-14		TI
Q1	FDS6898A	Dual N-MOSFET	SOIC-8	20 V, 10 mΩ at 4.5 V, 16 nC	Fairchild
D1	MBR0520LT1	Schottky Diode	SOD-123		
L1	DO3316P-682	Inductor		6.8 μH, 4.4 Arms, 27 mΩ	Coilcraft
C _{IN1}	16SP100M	Aluminum Electrolytic	10mm x 6mm	100 μF, 16 V, 2.89 Arms	Sanyo
C _{O1}	10SP56M	Aluminum Electrolytic	6.3mm x 6mm	56 μF, 10 V, 1.7 Arms	Sanyo
C _{CC} , C _{BOOT} , C _{IN2} , C _{O2}	VJ1206Y104KXXA	Capacitor	1206	0.1 μF, 10%	Vishay
C _{C3}	VJ0805Y182KXXA	Capacitor	805	1800 pF, 10%	Vishay
C _{SS}	VJ0805A123KXAA	Capacitor	805	12 nF, 10%	Vishay
C _{C2}	VJ0805A821KXAA	Capacitor	805	820 pF 10%	Vishay
C _{C1}	VJ0805A330KXAA	Capacitor	805	33 pF, 10%	Vishay
R _{FB2}	CRCW08051002F	Resistor	805	10.0 kΩ 1%	Vishay
R _{FB1}	CRCW08053161F	Resistor	805	3.16 kΩ 1%	Vishay
R _{FADJ}	CRCW08051103F	Resistor	805	110 kΩ 1%	Vishay
R _{C2}	CRCW08051301F	Resistor	805	1.3 kΩ 1%	Vishay
R _{CS}	CRCW08052101F	Resistor	805	2.1 kΩ 1%	Vishay
R _{CC}	CRCW080510R0F	Resistor	805	10.0 Ω 1%	Vishay
R _{C1}	CRCW08053322F	Resistor	805	33.2 kΩ 1%	Vishay
R _{PULL-UP}	CRCW08051003J	Resistor	805	100 kΩ 5%	Vishay

8.2.4 Example Circuit 3

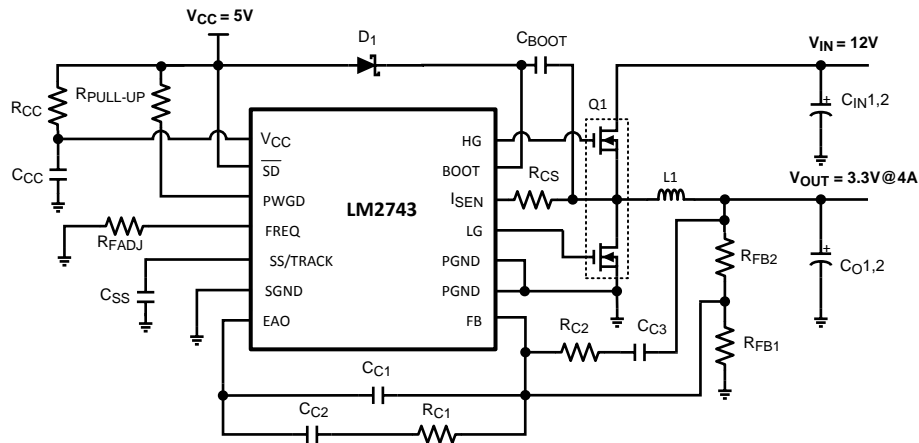

Figure 43. 12 V to 3.3 V at 4 A, $f_{SW} = 300$ kHz

8.2.4.1 Design Requirements

This design converts 12 V (V_{IN}) to 3.3 V (V_{OUT}) at a maximum load of 4 A, with a switching frequency of 300 kHz.

8.2.4.2 Detailed Design Procedure

Follow the detailed design procedure in [Detailed Design Procedure](#).

8.2.4.3 Bill of Materials

Table 3. Bill of Materials

PART	PART NUMBER	TYPE	PACKAGE	DESCRIPTION	VENDOR
U1	LM2743	Synchronous Controller	TSSOP-14		TI
Q1	FDS6898A	Dual N-MOSFET	SOIC-8	20 V, 10 mΩ at 4.5 V, 16 nC	Fairchild
D1	MBR0520LTI	Schottky Diode	SOD-123		
L1	DO3316P-332	Inductor		3.3 μH, 5.4 Arms, 15 mΩ	Coilcraft
C _{IN1}	16SP100M	Aluminum Electrolytic	10 mm x 6 mm	100 μF, 16 V, 2.89 Arms	Sanyo
C _{O1}	6SP220M	Aluminum Electrolytic	10 mm x 6 mm	220 μF, 6.3 V 3.1 Arms	Sanyo
C _{CC} , C _{BOOT} , C _{IN2} , C _{O2}	VJ1206Y104KXXA	Capacitor	1206	0.1 μF, 10%	Vishay
C _{C3}	VJ0805Y222KXXA	Capacitor	805	2200 pF, 10%	Vishay
C _{SS}	VJ0805A123KXAA	Capacitor	805	12 nF, 10%	Vishay
C _{C2}	VJ0805Y332KXXA	Capacitor	805	3300 pF 10%	Vishay
C _{C1}	VJ0805A820KXAA	Capacitor	805	82 pF, 10%	Vishay
R _{FB2}	CRCW08051002F	Resistor	805	10.0 kΩ 1%	Vishay
R _{FB1}	CRCW08052211F	Resistor	805	2.21 kΩ 1%	Vishay
R _{FADJ}	CRCW08051103F	Resistor	805	110 kΩ 1%	Vishay
R _{C2}	CRCW08052611F	Resistor	805	2.61 kΩ 1%	Vishay
R _{CS}	CRCW08054121F	Resistor	805	4.12 kΩ 1%	Vishay
R _{CC}	CRCW080510R0F	Resistor	805	10.0 Ω 1%	Vishay
R _{C1}	CRCW08051272F	Resistor	805	12.7 kΩ 1%	Vishay
R _{PULL-UP}	CRCW08051003J	Resistor	805	100 kΩ 5%	Vishay

9 Power Supply Recommendations

The LM2743 is a power management device. The power supply for the device is any DC voltage source within the specified input range (see [Design Requirements](#)).

10 Layout

10.1 Layout Guidelines

In a buck regulator, the primary switching loop consists of the input capacitor and MOSFET switches. Minimizing the area of this loop reduces the stray inductance, and minimizes noise and possible erratic operation. High quality input capacitors should be placed as close as possible to the MOSFET switches, with the positive side of the input capacitor connected directly to the high-side MOSFET drain, and the ground side of the capacitor connected as close as possible to the low-side MOSFET switch ground connection. Connect all of the low power ground connections directly to the SGND pin. Connect the VCC capacitor directly to the PGND pin.

10.2 Layout Example

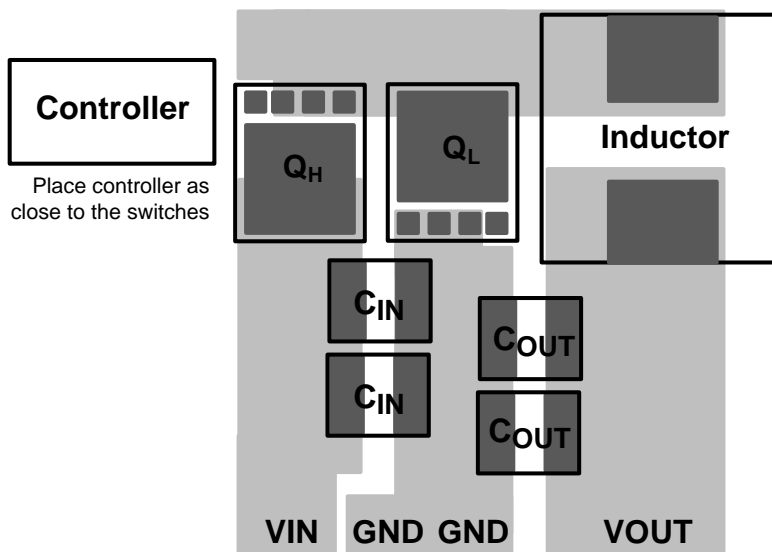

Figure 44. Layout Recommendation

11 Device and Documentation Support

11.1 Device Support

11.1.1 Development Support

11.1.1.1 Custom Design With WEBENCH® Tools

Click [here](#) to create a custom design using the LM2743 device with the WEBENCH® Power Designer.

1. Start by entering the input voltage (V_{IN}), output voltage (V_{OUT}), and output current (I_{OUT}) requirements.
2. Optimize the design for key parameters such as efficiency, footprint, and cost using the optimizer dial.
3. Compare the generated design with other possible solutions from Texas Instruments.

The WEBENCH Power Designer provides a customized schematic along with a list of materials with real-time pricing and component availability.

In most cases, these actions are available:

- Run electrical simulations to see important waveforms and circuit performance
- Run thermal simulations to understand board thermal performance
- Export customized schematic and layout into popular CAD formats
- Print PDF reports for the design, and share the design with colleagues

Get more information about WEBENCH tools at www.ti.com/WEBENCH.

11.2 Receiving Notification of Documentation Updates

To receive notification of documentation updates, navigate to the device product folder on ti.com. In the upper right corner, click on *Alert me* to register and receive a weekly digest of any product information that has changed. For change details, review the revision history included in any revised document.

11.3 Community Resources

The following links connect to TI community resources. Linked contents are provided "AS IS" by the respective contributors. They do not constitute TI specifications and do not necessarily reflect TI's views; see TI's [Terms of Use](#).

TI E2E™ Online Community *TI's Engineer-to-Engineer (E2E) Community*. Created to foster collaboration among engineers. At e2e.ti.com, you can ask questions, share knowledge, explore ideas and help solve problems with fellow engineers.

Design Support *TI's Design Support* Quickly find helpful E2E forums along with design support tools and contact information for technical support.

11.4 Trademarks

E2E is a trademark of Texas Instruments.
WEBENCH is a registered trademark of Texas Instruments.
All other trademarks are the property of their respective owners.

11.5 Electrostatic Discharge Caution



These devices have limited built-in ESD protection. The leads should be shorted together or the device placed in conductive foam during storage or handling to prevent electrostatic damage to the MOS gates.

11.6 Glossary

[SLYZ022](#) — *TI Glossary*.

This glossary lists and explains terms, acronyms, and definitions.

12 Mechanical, Packaging, and Orderable Information

The following pages include mechanical, packaging, and orderable information. This information is the most current data available for the designated devices. This data is subject to change without notice and revision of this document. For browser-based versions of this data sheet, refer to the left-hand navigation.

PACKAGING INFORMATION

Orderable Device	Status (1)	Package Type	Package Drawing	Pins	Package Qty	Eco Plan (2)	Lead finish/ Ball material (6)	MSL Peak Temp (3)	Op Temp (°C)	Device Marking (4/5)	Samples
LM2743MTC	LIFEBUY	TSSOP	PW	14	94	Non-RoHS & Green	Call TI	Level-1-260C-UNLIM	-40 to 125	2743 MTC	
LM2743MTC/NOPB	ACTIVE	TSSOP	PW	14	94	RoHS & Green	NIPDAU SN	Level-1-260C-UNLIM	-40 to 125	2743 MTC	Samples
LM2743MTCX/NOPB	ACTIVE	TSSOP	PW	14	2500	RoHS & Green	NIPDAU SN	Level-1-260C-UNLIM	-40 to 125	2743 MTC	Samples

(1) The marketing status values are defined as follows:

ACTIVE: Product device recommended for new designs.

LIFEBUY: TI has announced that the device will be discontinued, and a lifetime-buy period is in effect.

NRND: Not recommended for new designs. Device is in production to support existing customers, but TI does not recommend using this part in a new design.

PREVIEW: Device has been announced but is not in production. Samples may or may not be available.

OBSOLETE: TI has discontinued the production of the device.

(2) **RoHS:** TI defines "RoHS" to mean semiconductor products that are compliant with the current EU RoHS requirements for all 10 RoHS substances, including the requirement that RoHS substance do not exceed 0.1% by weight in homogeneous materials. Where designed to be soldered at high temperatures, "RoHS" products are suitable for use in specified lead-free processes. TI may reference these types of products as "Pb-Free".

RoHS Exempt: TI defines "RoHS Exempt" to mean products that contain lead but are compliant with EU RoHS pursuant to a specific EU RoHS exemption.

Green: TI defines "Green" to mean the content of Chlorine (Cl) and Bromine (Br) based flame retardants meet JS709B low halogen requirements of <=1000ppm threshold. Antimony trioxide based flame retardants must also meet the <=1000ppm threshold requirement.

(3) MSL, Peak Temp. - The Moisture Sensitivity Level rating according to the JEDEC industry standard classifications, and peak solder temperature.

(4) There may be additional marking, which relates to the logo, the lot trace code information, or the environmental category on the device.

(5) Multiple Device Markings will be inside parentheses. Only one Device Marking contained in parentheses and separated by a "~" will appear on a device. If a line is indented then it is a continuation of the previous line and the two combined represent the entire Device Marking for that device.

(6) Lead finish/Ball material - Orderable Devices may have multiple material finish options. Finish options are separated by a vertical ruled line. Lead finish/Ball material values may wrap to two lines if the finish value exceeds the maximum column width.

Important Information and Disclaimer:The information provided on this page represents TI's knowledge and belief as of the date that it is provided. TI bases its knowledge and belief on information provided by third parties, and makes no representation or warranty as to the accuracy of such information. Efforts are underway to better integrate information from third parties. TI has taken and continues to take reasonable steps to provide representative and accurate information but may not have conducted destructive testing or chemical analysis on incoming materials and chemicals. TI and TI suppliers consider certain information to be proprietary, and thus CAS numbers and other limited information may not be available for release.

In no event shall TI's liability arising out of such information exceed the total purchase price of the TI part(s) at issue in this document sold by TI to Customer on an annual basis.

TAPE AND REEL INFORMATION

QUADRANT ASSIGNMENTS FOR PIN 1 ORIENTATION IN TAPE



*All dimensions are nominal

Device	Package Type	Package Drawing	Pins	SPQ	Reel Diameter (mm)	Reel Width W1 (mm)	A0 (mm)	B0 (mm)	K0 (mm)	P1 (mm)	W (mm)	Pin1 Quadrant
LM2743MTCX/NOPB	TSSOP	PW	14	2500	330.0	12.4	6.95	5.6	1.6	8.0	12.0	Q1

TAPE AND REEL BOX DIMENSIONS

*All dimensions are nominal

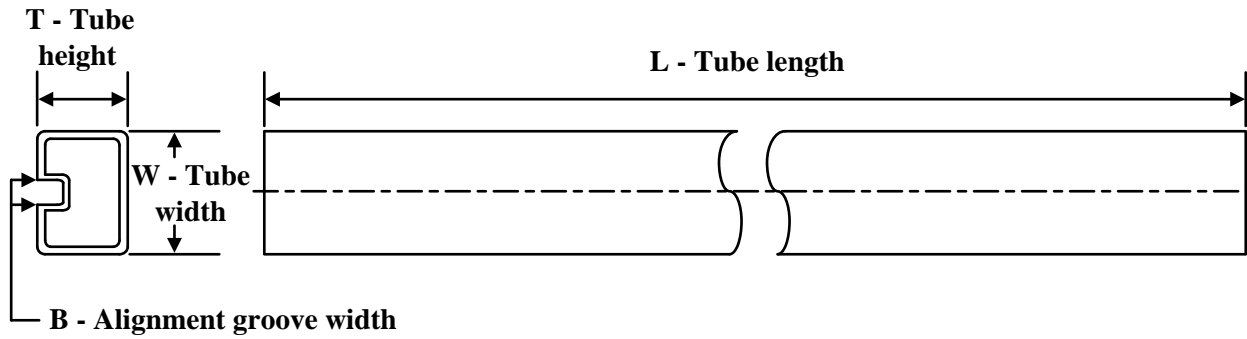
Device	Package Type	Package Drawing	Pins	SPQ	Length (mm)	Width (mm)	Height (mm)
LM2743MTCX/NOPB	TSSOP	PW	14	2500	367.0	367.0	35.0

TUBE



*All dimensions are nominal

Device	Package Name	Package Type	Pins	SPQ	L (mm)	W (mm)	T (μm)	B (mm)
LM2743MTC	PW	TSSOP	14	94	495	8	2514.6	4.06
LM2743MTC	PW	TSSOP	14	94	495	8	2514.6	4.06
LM2743MTC/NOPB	PW	TSSOP	14	94	495	8	2514.6	4.06
LM2743MTC/NOPB	PW	TSSOP	14	94	530	10.2	3600	3.5
LM2743MTC/NOPB	PW	TSSOP	14	94	495	8	2514.6	4.06

PW (R-PDSO-G14)

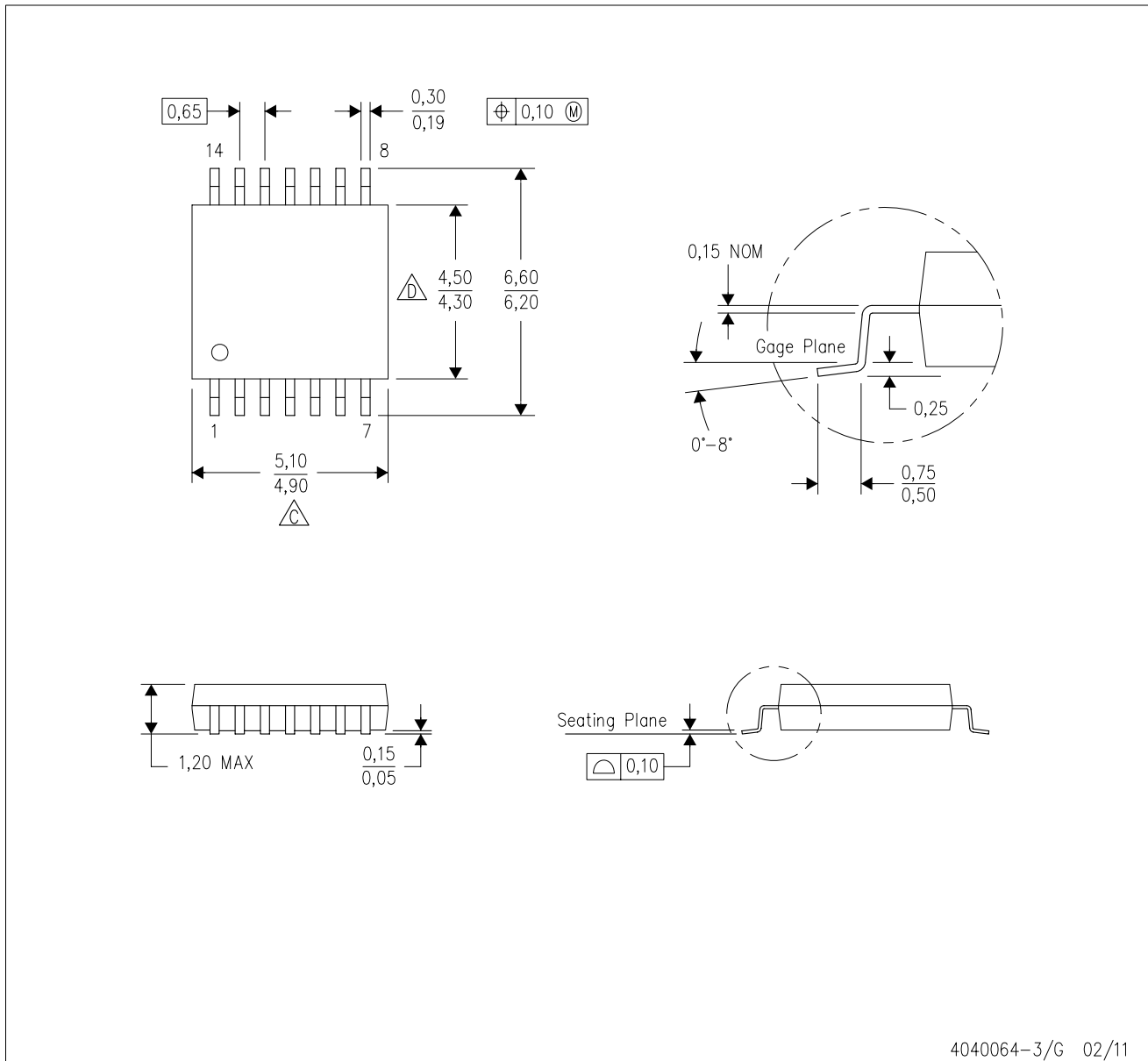
PLASTIC SMALL OUTLINE



- NOTES:
- A. All linear dimensions are in millimeters. Dimensioning and tolerancing per ASME Y14.5M-1994.
 - B. This drawing is subject to change without notice.
 -  Body length does not include mold flash, protrusions, or gate burrs. Mold flash, protrusions, or gate burrs shall not exceed 0,15 each side.
 -  Body width does not include interlead flash. Interlead flash shall not exceed 0,25 each side.
 - E. Falls within JEDEC MO-153

PW (R-PDSO-G14)

PLASTIC SMALL OUTLINE

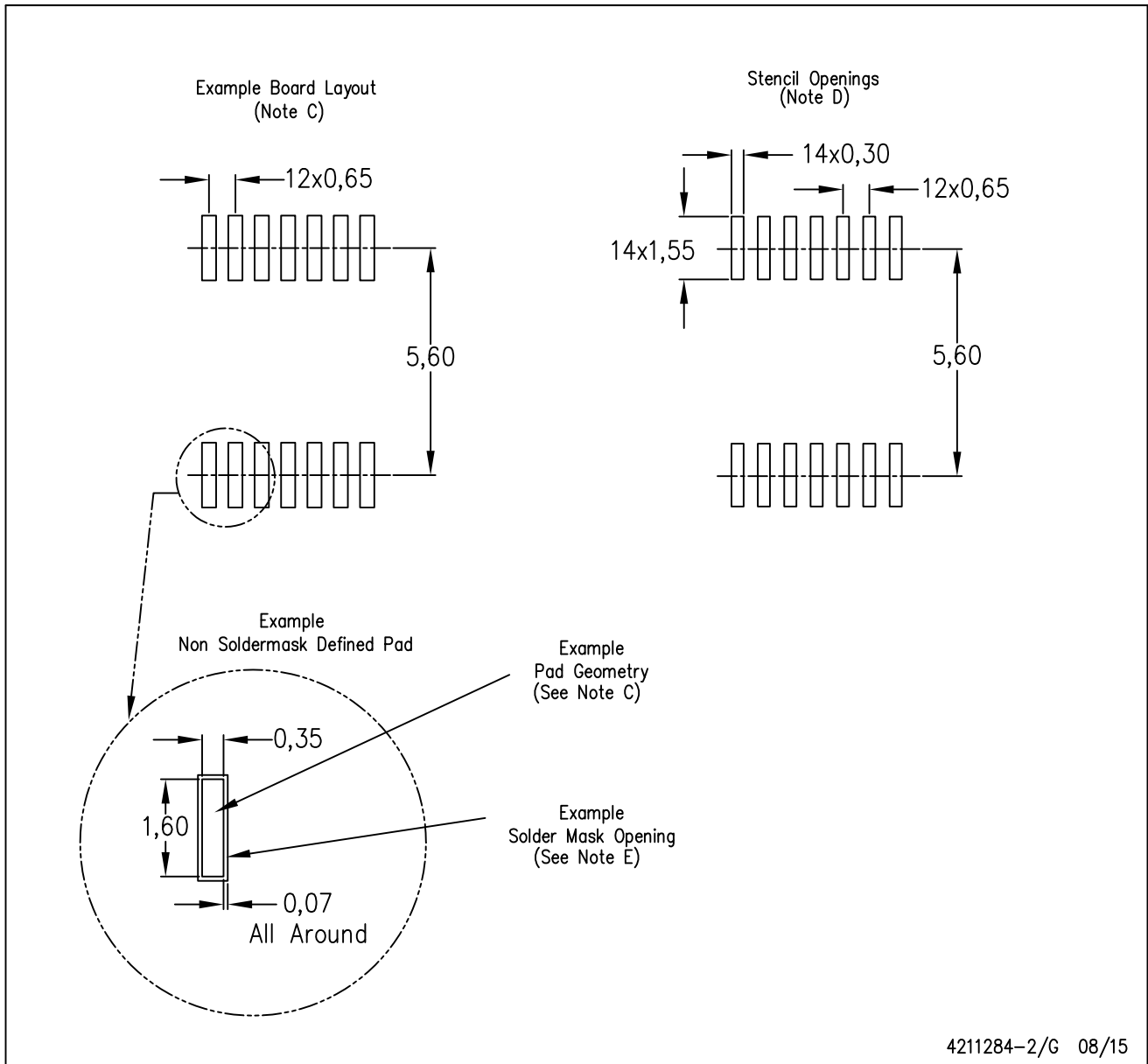

- NOTES:
- All linear dimensions are in millimeters.
 - This drawing is subject to change without notice.
 - Publication IPC-7351 is recommended for alternate designs.
 - Laser cutting apertures with trapezoidal walls and also rounding corners will offer better paste release. Customers should contact their board assembly site for stencil design recommendations. Refer to IPC-7525 for other stencil recommendations.
 - Customers should contact their board fabrication site for solder mask tolerances between and around signal pads.

IMPORTANT NOTICE AND DISCLAIMER

TI PROVIDES TECHNICAL AND RELIABILITY DATA (INCLUDING DATA SHEETS), DESIGN RESOURCES (INCLUDING REFERENCE DESIGNS), APPLICATION OR OTHER DESIGN ADVICE, WEB TOOLS, SAFETY INFORMATION, AND OTHER RESOURCES "AS IS" AND WITH ALL FAULTS, AND DISCLAIMS ALL WARRANTIES, EXPRESS AND IMPLIED, INCLUDING WITHOUT LIMITATION ANY IMPLIED WARRANTIES OF MERCHANTABILITY, FITNESS FOR A PARTICULAR PURPOSE OR NON-INFRINGEMENT OF THIRD PARTY INTELLECTUAL PROPERTY RIGHTS.

These resources are intended for skilled developers designing with TI products. You are solely responsible for (1) selecting the appropriate TI products for your application, (2) designing, validating and testing your application, and (3) ensuring your application meets applicable standards, and any other safety, security, regulatory or other requirements.

These resources are subject to change without notice. TI grants you permission to use these resources only for development of an application that uses the TI products described in the resource. Other reproduction and display of these resources is prohibited. No license is granted to any other TI intellectual property right or to any third party intellectual property right. TI disclaims responsibility for, and you will fully indemnify TI and its representatives against, any claims, damages, costs, losses, and liabilities arising out of your use of these resources.

TI's products are provided subject to [TI's Terms of Sale](#) or other applicable terms available either on [ti.com](https://www.ti.com) or provided in conjunction with such TI products. TI's provision of these resources does not expand or otherwise alter TI's applicable warranties or warranty disclaimers for TI products.

TI objects to and rejects any additional or different terms you may have proposed.

Mailing Address: Texas Instruments, Post Office Box 655303, Dallas, Texas 75265
Copyright © 2023, Texas Instruments Incorporated

Looking for pricing, stock, or lifecycle information?

Click below to explore more details on WIN SOURCE:

 [View LM2743MTCX/NOPB on WIN SOURCE](#)

 [Texas Instruments](#) Information

Optimize Your Supply Chain with WIN SOURCE Solutions

-  Global Sourcing Solution
-  Obsolete Management
-  Cost Control Management
-  Shortage Management
-  Alternative Solution
-  Excess Inventory Management