



THE DATASHEET OF LM2787BPX



LM2787 Low Noise Regulated Switched Capacitor Voltage Inverter in DSBGA

Check for Samples: [LM2787](#)

FEATURES

- Inverts and Regulates the Input Supply Voltage
- Small 8-Bump DSBGA and Thin DSBGA Packages
- 91% Typical Charge Pump Power Efficiency at 10mA
- Low Output Ripple
- Shutdown Lowers Quiescent Current to 0.05 μA (Typical)

APPLICATIONS

- Wireless Communication Systems
- Cellular Phone Power Amplifier Biasing
- Interface Power Supplies
- Handheld Instrumentation
- Laptop Computers and PDA's

DESCRIPTION

The LM2787 CMOS Negative Regulated Switched Capacitor Voltage Inverter delivers a very low noise adjustable output for an input voltage in the range of +2.7V to +5.5V. Four low cost capacitors are used in this circuit to provide up to 10mA of output current. The regulated output for the LM2787 is adjustable between -1.5V and -5.2V. The LM2787 operates at 260 kHz (typical) switching frequency to reduce output resistance and voltage ripple. With an operating current of only 400 μA (charge pump power efficiency greater than 90% with most loads) and 0.05 μA typical shutdown current, the LM2787 provides ideal performance for cellular phone power amplifier bias and other low current, low noise negative voltage needs. The device comes in small 8-Bump DSBGA and thin DSBGA packages.

Typical Application Circuit and Connection Diagram

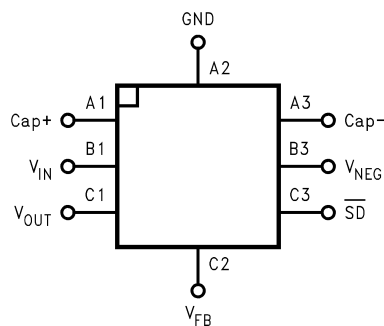
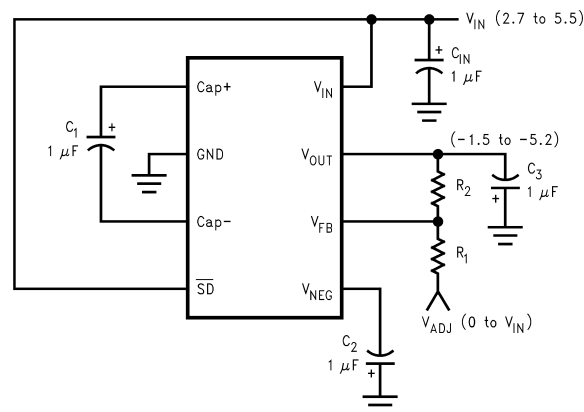
8-Bump DSBGA (Top View)

Please be aware that an important notice concerning availability, standard warranty, and use in critical applications of Texas Instruments semiconductor products and disclaimers thereto appears at the end of this data sheet.

All trademarks are the property of their respective owners.

PIN DESCRIPTIONS

Pin No.	Name	Function
A1	Cap+	Positive terminal for C ₁ .
B1	V _{IN}	Positive power supply input.
C1	V _{OUT}	Regulated negative output voltage.
C2	V _{FB}	Feedback input. Connect V _{FB} to an external resistor divider between V _{OUT} and a positive adjust voltage V _{ADJ} (0 ≤ V _{ADJ} ≤ V _{IN}). DO NOT leave unconnected.
C3	\overline{SD}	Active low, logic-level shutdown input.
B3	V _{NEG}	Negative unregulated output voltage.
A3	Cap-	Negative terminal for C ₁ .
A2	GND	Ground.



These devices have limited built-in ESD protection. The leads should be shorted together or the device placed in conductive foam during storage or handling to prevent electrostatic damage to the MOS gates.

Absolute Maximum Ratings⁽¹⁾⁽²⁾

Supply Voltage (V _{IN} to GND or GND to OUT)	+ 5.8V
\overline{SD}	(GND - 0.3V) to (V _{IN} + 0.3V)
V _{NEG} and V _{OUT} Continuous Output Current	10mA
V _{OUT} Short-Circuit Duration to GND ⁽³⁾	1 sec.
Continuous Power Dissipation (T _A = 25°C) ⁽⁴⁾	600mW
T _{JMAX} ⁽⁴⁾	150°C
θ _{JA} ⁽⁴⁾	220°C/W
Operating Input Voltage Range	2.7V to 5.5V
Operating Output Current Range	0mA to 10mA
Operating Ambient Temp. Range	-40°C to 85°C
Operating Junction Temp. Range	-40°C to 110°C
Storage Temperature	-65°C to 150°C
Lead Temp. (Soldering, 10 sec.)	300°C
ESD Rating ⁽⁵⁾	2kV

- (1) Absolute Maximum Ratings indicate limits beyond which damage to the device may occur. Electrical specifications do not apply when operating the device beyond its rated operating conditions.
- (2) If Military/Aerospace specified devices are required, please contact the TI Sales Office/Distributors for availability and specifications.
- (3) OUT may be shorted to GND for one second without damage. However, shorting OUT to V_{IN} may damage the device and must be avoided. Also, for temperatures above T_A = 85°C, OUT must not be shorted to GND or V_{IN} or device may be damaged.
- (4) The maximum power dissipation must be de-rated at elevated temperatures and is limited by T_{JMAX} (maximum junction temperature), T_A (ambient temperature) and θ_{JA} (junction-to-ambient thermal resistance). The maximum power dissipation at any temperature is: P_{DissMAX} = (T_{JMAX} - T_A)/θ_{JA} up to the value listed in the Absolute Maximum Ratings.
- (5) Rating is for the human body model, a 100pF capacitor discharged through a 1.5 kΩ resistor into each pin.

Electrical Characteristics

Limits with standard typeface apply for T_J = 25°C, and limits in **boldface type** apply over the full temperature range. Unless otherwise specified V_{IN} = 3.6V, C₁ = C₂ = C₃ = 1μF.

Symbol	Parameter	Conditions	Min	Typ	Max	Units
I _Q	Supply Current	Open Circuit, No Load		400	950	μA
I _{SD}	Shutdown Supply Current			0.05	1	μA
F _{SW}	Switching Frequency ⁽¹⁾	V _{IN} = 3.6V	140	260	450	kHz
η _{POWER}	Power Efficiency at V _{NEG}	I _L = 3.6mA I _L = 10mA		94 91		%
T _{START}	Start Up time			120	600	μs

(1) The output switches operate at one half the oscillator frequency, f_{OSC} = 2f_{SW}.

Electrical Characteristics (continued)

Limits with standard typeface apply for $T_J = 25^\circ\text{C}$, and limits in **boldface type** apply over the full temperature range. Unless otherwise specified $V_{IN} = 3.6\text{V}$, $C_1 = C_2 = C_3 = 1\mu\text{F}$.

Symbol	Parameter	Conditions	Min	Typ	Max	Units
R_{NEG}	Output Resistance to V_{NEG}	See ⁽²⁾		30		Ω
V_R	Output Voltage Ripple ⁽³⁾	$I_L = 2.5\text{mA}$, $V_{OUT} = -2.7\text{V}$ $I_L = 10\text{mA}$, $V_{OUT} = -3.8\text{V}$		1		mV
V_{FB}	Feedback Pin Reference Voltage	$I_L = 2.5\text{mA}$ ⁽⁴⁾	-1.25	-1.20	-1.15	V
V_{OUT}	Adjustable Output Voltage	$5.5\text{V} \geq V_{IN} \geq 2.7\text{V}$, $2.5\text{mA} \geq I_L$ $5.5\text{V} \geq V_{IN} \geq 3.0\text{V}$, $10\text{mA} \geq I_L \geq 0\text{mA}$	$-(V_{IN} - 0.3\text{V})$ $-(V_{IN} - 1.2\text{V})$			V
	Load Regulation	0 to 10mA, $V_{OUT} = -2.4\text{V}$		5		mV/mA
	Line Regulation	$5.5\text{V} \geq V_{IN} \geq 2.7\text{V}$, $I_L = 2.5\text{mA}$		1		mV/V
V_{IH}	Shutdown Pin Input Voltage High	$5.5\text{V} \geq V_{IN} \geq 2.7\text{V}$	2.4			V
V_{IL}	Shutdown Pin Input Voltage Low	$5.5\text{V} \geq V_{IN} \geq 2.7\text{V}$			0.8	V

- (2) Current drawn from V_{NEG} pin decreases power efficiency and will increase output voltage ripple.
 (3) In the test circuit, capacitors C_1 , C_2 , and C_3 are $1\mu\text{F}$, 0.30Ω maximum ESR capacitors. Capacitors with higher ESR will increase output resistance, increase output voltage ripple, and reduce efficiency.
 (4) The feedback resistors R_1 and R_2 are $200\text{k}\Omega$ resistors.

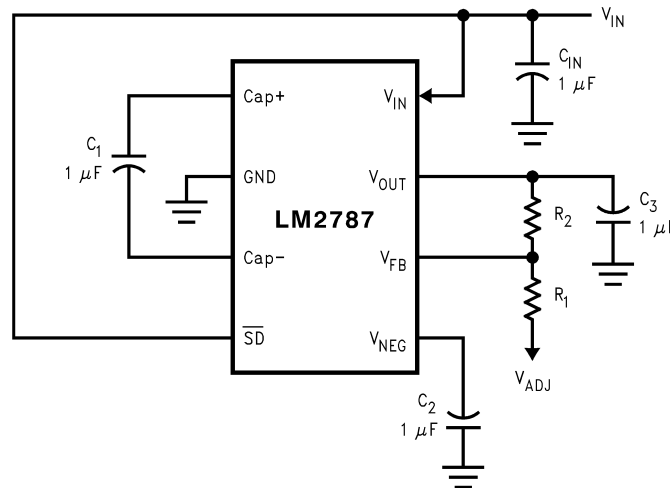

Figure 1. Standard Application Circuit

Typical Performance Characteristics

Unless otherwise specified, $T_A = 25^\circ\text{C}$, $V_{\text{OUT}} = -2.5\text{V}$.

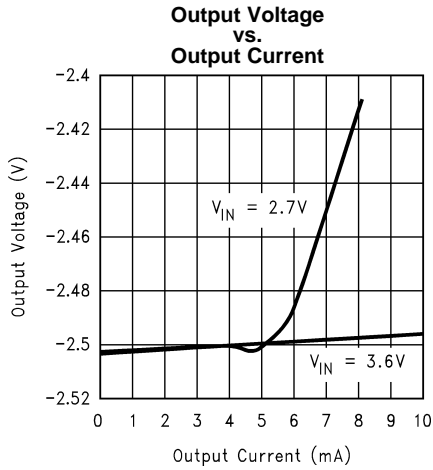

Figure 2.

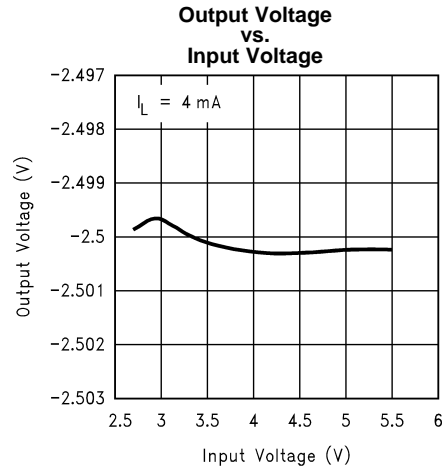

Figure 3.

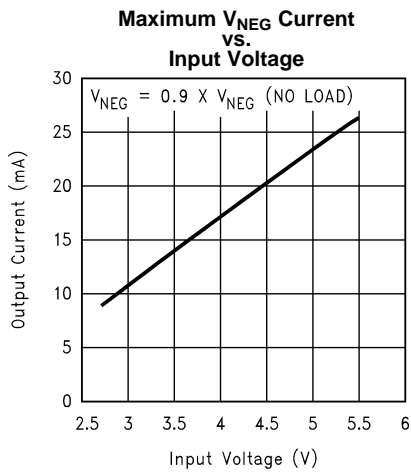

Figure 4.

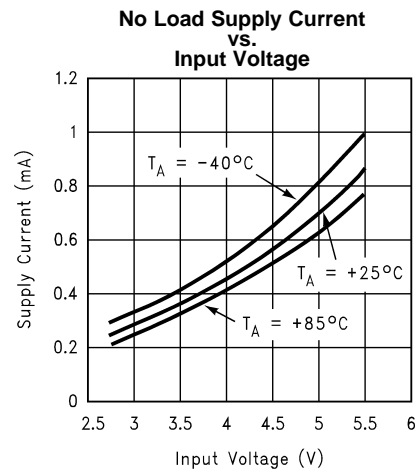

Figure 5.

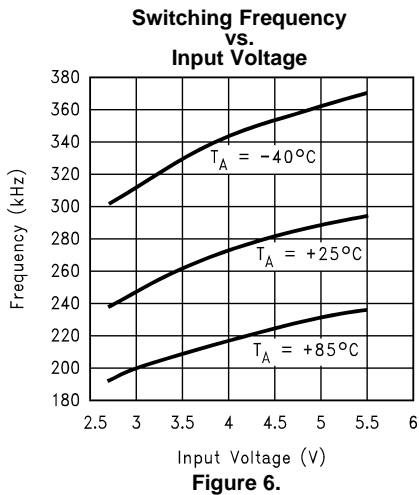

Figure 6.

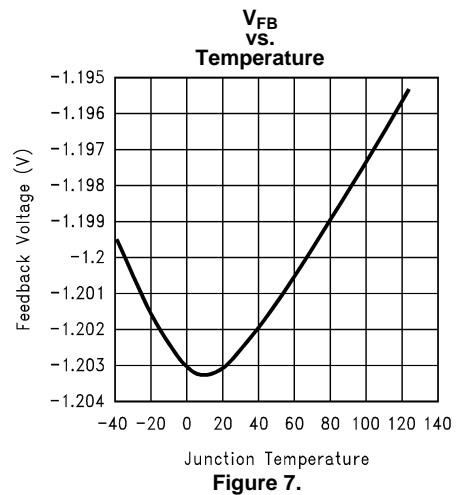
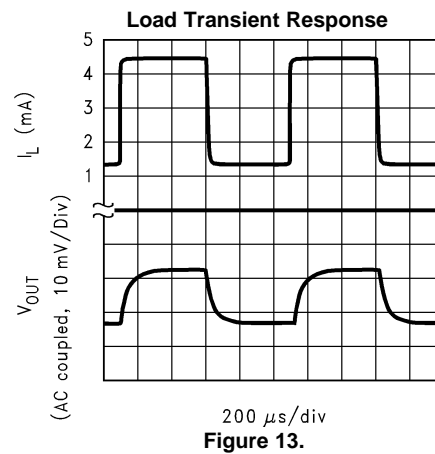
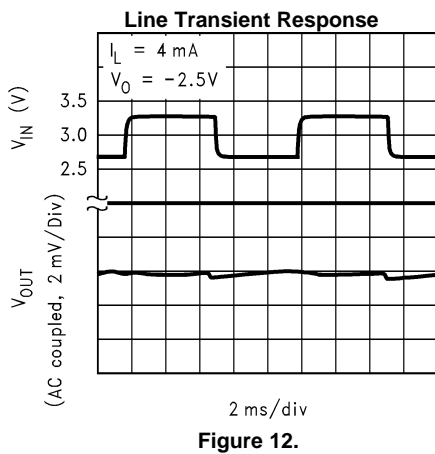
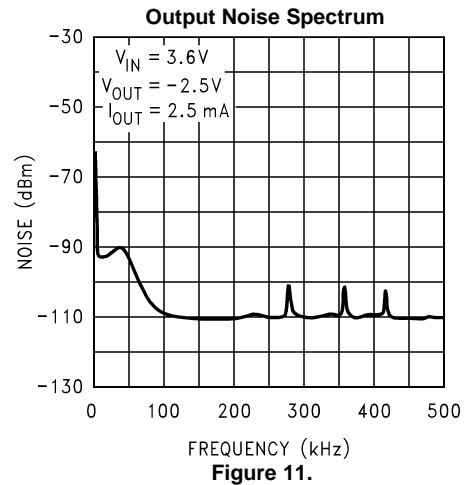
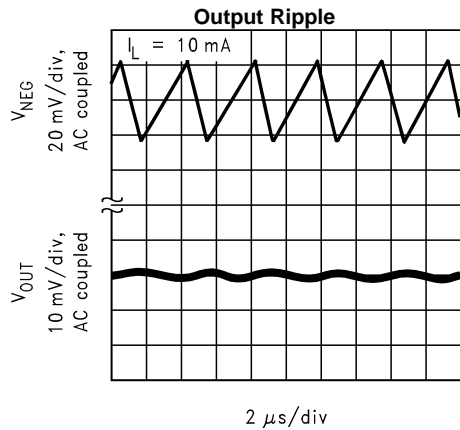
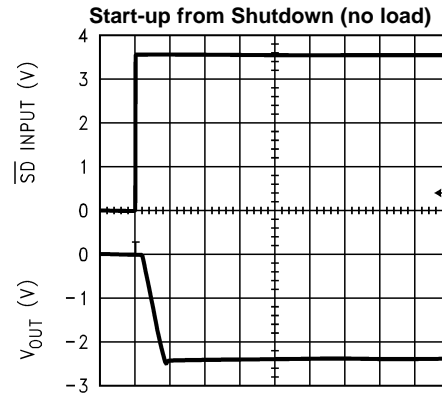
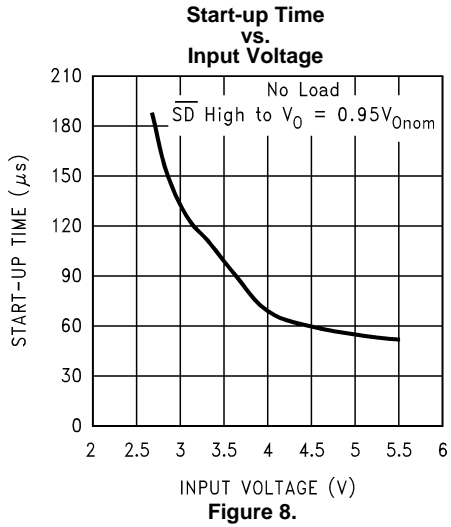

Figure 7.

Typical Performance Characteristics (continued)

Unless otherwise specified, $T_A = 25^\circ\text{C}$, $V_{OUT} = -2.5\text{V}$.



FUNCTIONAL BLOCK DIAGRAM

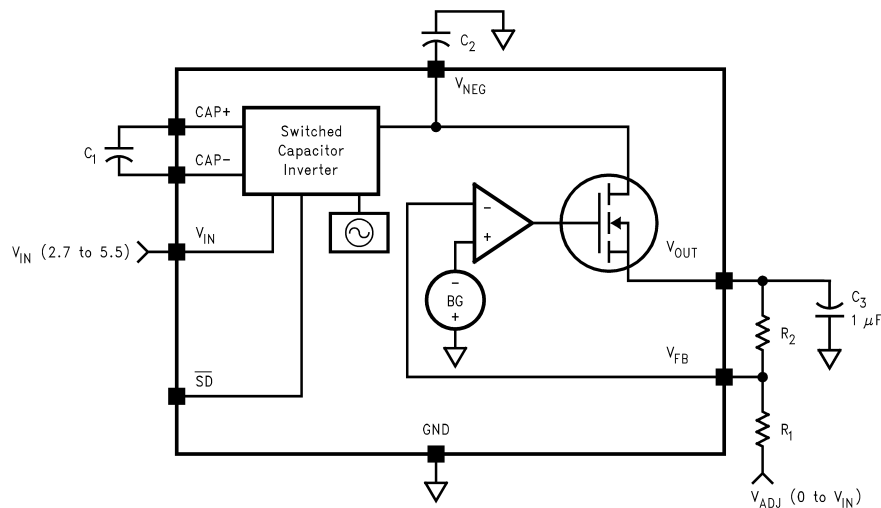

Figure 14. Functional Block Diagram

Device Description

The LM2787 is an inverting, regulated charge-pump power converter. It features low noise, small physical size, and is simple to use. It is an ideal solution for biasing GaAsFET devices such as power amplifier modules found in portable devices and cellular phones.

A switched capacitor charge-pump circuit is used to invert the input voltage V_{IN} to its corresponding negative value which is seen at V_{NEG} . This voltage is regulated by a low dropout linear regulator at V_{OUT} (Figure 14). The output voltage can be regulated anywhere from $-1.5V$ to $-5.2V$ and is determined by a pair of feedback resistors (see [Setting the Output Voltage](#)). The PSRR of the linear regulator reduces the output voltage ripple produced by the charge-pump inverter at the output V_{OUT} . The regulator also attenuates noise from the incoming supply due to its high PSRR.

Shutdown

The LM2787 features a logic-level shutdown feature. The function is active-low and will reduce the supply current to $0.05\mu A$ (typical) when engaged. When shutdown is active V_{OUT} and V_{NEG} are switched to ground.

APPLICATION INFORMATION

Setting the Output Voltage

The output voltage on the LM2787 is set by using a resistor divider between the output, the feedback pin, and an arbitrary voltage V_{ADJ} (Figure 14). V_{ADJ} can range from GND to any positive voltage up to V_{IN} . V_{ADJ} is usually chosen to be GND and should not be connected to a different voltage unless it is well regulated so the output will stay constant. The feedback pin is held at a constant voltage V_{FB} which equals $-1.2V$. The output voltage can be selected using the equation:

$$V_{OUT} = \frac{R_2}{R_1} (V_{FB} - V_{ADJ}) + V_{FB} \quad (1)$$

The current into the feedback pin I_{FB} is in the range of $10nA$ to $100nA$. Therefore using a value of $500k\Omega$ or smaller for R_1 should make this current of little concern when setting the output voltage. For best accuracy, use resistors with 1% or better tolerance.

Capacitor Selection

Selecting the right capacitors for your circuit is important. The capacitors affect the output resistance of the charge-pump, the output voltage ripple, and the overall dropout voltage ($V_{IN}-|V_{OUT}|$) of the circuit. The output resistance of the charge-pump inverter is:

$$R_{NEG} = R_{SW} + 4ESR_{C1} + ESR_{C2} + \frac{1}{f_{SW} \times C1} \quad (2)$$

The switching frequency is fixed at 260kHz and R_{SW} (the combined resistance of the internal switches) is typically 10Ω. It is clear from this equation that low ESR capacitors are desirable and that larger values of C_1 will further reduce the output resistance. The output resistance of the entire circuit (in dropout) is:

$$R_{OUT} = R_{NEG} + R_{regulator} \quad (3)$$

$R_{regulator}$ (the output impedance of the linear regulator) is approximately 10Ω. When the circuit is in regulation, the overall output resistance is equal to the linear regulator load regulation (5mV/mA). The dropout voltage is therefore affected by the capacitors used since it is simply defined as $I_{OUT} \times R_{OUT}$.

A larger value of capacitor and lower ESR for C_2 will lower the output voltage ripple of the charge-pump. This ripple will then be subject to the PSRR of the linear regulator and reduced at V_{OUT} .

In summation, larger value capacitors with lower ESR will give the lowest output noise and ripple. C_1 , C_2 , and C_3 should be 1.0μF minimum with less than 0.3Ω ESR. Larger values may be used for any or all capacitors. All capacitors should be either ceramic, surface-mount chip tantalum, or polymer electrolytic.

Output Noise and Ripple

Low output noise and output voltage ripple are two of the attractive features of the LM2787. Because they are small, the noise and ripple can be hard to measure accurately. Ground loop error between the circuit and the oscilloscope caused by the switching of the charge-pump produces ground currents in the probe wires. This causes sharp voltage spikes on the oscilloscope waveform. To reduce this error, measure the output directly at the output capacitor (C_3) and use the shortest wires possible. Also, do not use the ground lead on the probe. Take the tip cover off of the probe and touch the grounding ring of the probe directly to the output ground. This should give the most accurate reading of the actual output waveform.

DSBGA Mounting

The DSBGA package requires specific mounting techniques which are detailed in Application Note AN1112. Referring to the section **Surface Mount Technology (SMT) Assembly Considerations**, it should be noted that the pad style which must be used with the 8-pin package is the NSMD (non-solder mask defined) type.

For best results during assembly, alignment ordinals on the PC board may be used to facilitate placement of the DSBGA device.

DSBGA Light Sensitivity

Exposing the DSBGA device to direct sunlight may cause misoperation of the device. Light sources such as Halogen lamps can also affect electrical performance if brought near the device.

The wavelengths which have the most detrimental effect are reds and infra-reds. The fluorescent lighting used inside of most buildings has very little effect on performance.

REVISION HISTORY

Changes from Revision E (May 2013) to Revision F	Page
• Changed layout of National Data Sheet to TI format	7

IMPORTANT NOTICE

Texas Instruments Incorporated and its subsidiaries (TI) reserve the right to make corrections, enhancements, improvements and other changes to its semiconductor products and services per JESD46, latest issue, and to discontinue any product or service per JESD48, latest issue. Buyers should obtain the latest relevant information before placing orders and should verify that such information is current and complete. All semiconductor products (also referred to herein as "components") are sold subject to TI's terms and conditions of sale supplied at the time of order acknowledgment.

TI warrants performance of its components to the specifications applicable at the time of sale, in accordance with the warranty in TI's terms and conditions of sale of semiconductor products. Testing and other quality control techniques are used to the extent TI deems necessary to support this warranty. Except where mandated by applicable law, testing of all parameters of each component is not necessarily performed.

TI assumes no liability for applications assistance or the design of Buyers' products. Buyers are responsible for their products and applications using TI components. To minimize the risks associated with Buyers' products and applications, Buyers should provide adequate design and operating safeguards.

TI does not warrant or represent that any license, either express or implied, is granted under any patent right, copyright, mask work right, or other intellectual property right relating to any combination, machine, or process in which TI components or services are used. Information published by TI regarding third-party products or services does not constitute a license to use such products or services or a warranty or endorsement thereof. Use of such information may require a license from a third party under the patents or other intellectual property of the third party, or a license from TI under the patents or other intellectual property of TI.

Reproduction of significant portions of TI information in TI data books or data sheets is permissible only if reproduction is without alteration and is accompanied by all associated warranties, conditions, limitations, and notices. TI is not responsible or liable for such altered documentation. Information of third parties may be subject to additional restrictions.

Resale of TI components or services with statements different from or beyond the parameters stated by TI for that component or service voids all express and any implied warranties for the associated TI component or service and is an unfair and deceptive business practice. TI is not responsible or liable for any such statements.

Buyer acknowledges and agrees that it is solely responsible for compliance with all legal, regulatory and safety-related requirements concerning its products, and any use of TI components in its applications, notwithstanding any applications-related information or support that may be provided by TI. Buyer represents and agrees that it has all the necessary expertise to create and implement safeguards which anticipate dangerous consequences of failures, monitor failures and their consequences, lessen the likelihood of failures that might cause harm and take appropriate remedial actions. Buyer will fully indemnify TI and its representatives against any damages arising out of the use of any TI components in safety-critical applications.

In some cases, TI components may be promoted specifically to facilitate safety-related applications. With such components, TI's goal is to help enable customers to design and create their own end-product solutions that meet applicable functional safety standards and requirements. Nonetheless, such components are subject to these terms.

No TI components are authorized for use in FDA Class III (or similar life-critical medical equipment) unless authorized officers of the parties have executed a special agreement specifically governing such use.

Only those TI components which TI has specifically designated as military grade or "enhanced plastic" are designed and intended for use in military/aerospace applications or environments. Buyer acknowledges and agrees that any military or aerospace use of TI components which have **not** been so designated is solely at the Buyer's risk, and that Buyer is solely responsible for compliance with all legal and regulatory requirements in connection with such use.

TI has specifically designated certain components as meeting ISO/TS16949 requirements, mainly for automotive use. In any case of use of non-designated products, TI will not be responsible for any failure to meet ISO/TS16949.

Products

Audio	www.ti.com/audio
Amplifiers	amplifier.ti.com
Data Converters	dataconverter.ti.com
DLP® Products	www.dlp.com
DSP	dsp.ti.com
Clocks and Timers	www.ti.com/clocks
Interface	interface.ti.com
Logic	logic.ti.com
Power Mgmt	power.ti.com
Microcontrollers	microcontroller.ti.com
RFID	www.ti-rfid.com
OMAP Applications Processors	www.ti.com/omap
Wireless Connectivity	www.ti.com/wirelessconnectivity

Applications

Automotive and Transportation	www.ti.com/automotive
Communications and Telecom	www.ti.com/communications
Computers and Peripherals	www.ti.com/computers
Consumer Electronics	www.ti.com/consumer-apps
Energy and Lighting	www.ti.com/energy
Industrial	www.ti.com/industrial
Medical	www.ti.com/medical
Security	www.ti.com/security
Space, Avionics and Defense	www.ti.com/space-avionics-defense
Video and Imaging	www.ti.com/video

TI E2E Community

e2e.ti.com

Looking for pricing, stock, or lifecycle information?

Click below to explore more details on WIN SOURCE:

 [View LM2787BPX on WIN SOURCE](#)

 [Texas Instruments](#) Information

Optimize Your Supply Chain with WIN SOURCE Solutions

-  Global Sourcing Solution
-  Obsolete Management
-  Cost Control Management
-  Shortage Management
-  Alternative Solution
-  Excess Inventory Management