



**THE DATASHEET OF
LM2788MM-1.8/NOPB**



LM2788 120mA High Efficiency Step-Down Switched Capacitor Voltage Converter

Check for Samples: [LM2788](#)

FEATURES

- **Output Voltage Options:**
 - 2.0V ± 5%, 1.8V ± 5%, 1.5V ± 6%
- **120mA Output Current Capability**
- **Multi-Gain and Gain Hopping for Highest Possible Efficiency - up to 90% Efficient**
- **2.6V to 5.5V Input Range**
- **Low Operating Supply Current: 32µA**
- **Shutdown Supply Current: 0.1µA**
- **Thermal and Short Circuit Protection**
- **Available in an 8-Pin VSSOP Package**

APPLICATIONS

- Cellular Phones
- Pagers
- H/PC and P/PC Devices
- Portable Electronic Equipment
- Handheld Instrumentation

Typical Application Circuit

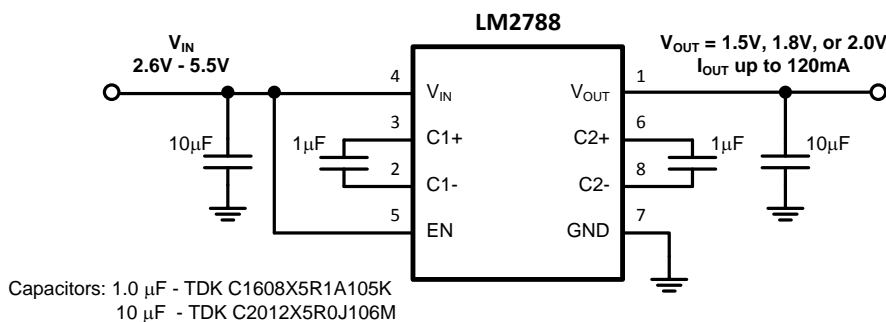

DESCRIPTION

The LM2788 switched capacitor step-down DC/DC converter efficiently produces a 120mA regulated low-voltage rail from a 2.6V to 5.5V input. Fixed output voltage options of 1.5V, 1.8V, and 2.0V are available. The LM2788 uses multiple fractional gain configurations to maximize conversion efficiency over the entire input voltage and output current ranges. Also contributing to high overall efficiency is the extremely low supply current of the LM2788: 32µA operating unloaded and 0.1µA in shutdown.

The optimal external component requirements of the LM2788 solution minimize size and cost, making the part ideal for Li-Ion and other battery powered designs. Two 1µF flying capacitors and two 10µF bypass capacitors are all that are required, and no inductors are needed.

The LM2788 also features noise-reducing soft-start circuitry, short-circuit protection and over-temperature protection.



Please be aware that an important notice concerning availability, standard warranty, and use in critical applications of Texas Instruments semiconductor products and disclaimers thereto appears at the end of this data sheet.

All trademarks are the property of their respective owners.

Connection Diagram

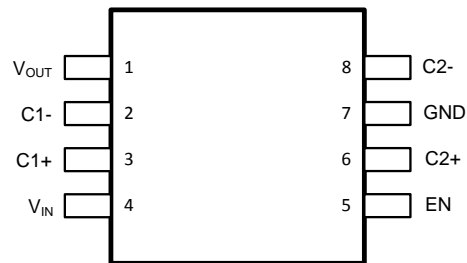

**Figure 1. LM2788
VSSOP-8 Package
Package #: DGK0008A
Top View**

PIN DESCRIPTIONS

Pin	Name	Description
1	V _{OUT}	Regulated Output Voltage
2	C1-	First Flying Capacitor: Negative Terminal
3	C1+	First Flying Capacitor: Positive terminal
4	V _{IN}	Input voltage. Recommended V _{IN} Range: 2.6V to 5.5V
5	EN	Enable. Logic Input. High voltage = ON, Low voltage = SHUTDOWN
6	C2+	Second Flying-Capacitor: Positive Terminal
7	GND	Ground Connection
8	C2-	Second Flying Capacitor: Negative Terminal



These devices have limited built-in ESD protection. The leads should be shorted together or the device placed in conductive foam during storage or handling to prevent electrostatic damage to the MOS gates.

ABSOLUTE MAXIMUM RATINGS⁽¹⁾⁽²⁾⁽³⁾

V_{IN} , EN pins: Voltage to Ground ⁽⁴⁾	-0.3V to 5.6V
Junction Temperature ($T_{J-MAX-ABS}$)	150°C
Continuous Power Dissipation ⁽⁵⁾	Internally Limited
V_{OUT} Short-Circuit to GND Duration ⁽⁵⁾	Unlimited
Storage Temperature Range	-65°C to 150°C
Lead Temperature (Soldering, 5 Sec.)	260°C
ESD Rating ⁽⁶⁾ Human-body model: Machine model	2 kV 200V

- (1) Absolute Maximum Ratings indicate limits beyond which damage to the component may occur. Operating Ratings are conditions under which operation of the device is specified. Operating Ratings do not imply ensured performance limits. For ensured performance limits and associated test conditions, see the Electrical Characteristics tables.
- (2) All voltages are with respect to the potential at the GND pin.
- (3) If Military/Aerospace specified devices are required, please contact the Texas Instruments Sales Office/Distributors for availability and specifications.
- (4) Voltage on the EN pin must not be brought above $V_{IN} + 0.3V$.
- (5) Thermal shutdown circuitry protects the device from permanent damage.
- (6) The Human body model is a 100 pF capacitor discharged through a 1.5 k Ω resistor into each pin. The machine model is a 200pF capacitor discharged directly into each pin.

OPERATING RATINGS⁽¹⁾⁽²⁾

Input Voltage Range	2.6V to 5.5V
Recommended Output Current Range	0mA to 120mA
Junction Temperature Range	-40°C to 125°C
Ambient Temperature Range ⁽³⁾	-40°C to 85°C

- (1) Absolute Maximum Ratings indicate limits beyond which damage to the component may occur. Operating Ratings are conditions under which operation of the device is specified. Operating Ratings do not imply ensured performance limits. For ensured performance limits and associated test conditions, see the Electrical Characteristics tables.
- (2) All voltages are with respect to the potential at the GND pin.
- (3) Maximum ambient temperature (T_{A-MAX}) is dependent on the maximum operating junction temperature ($T_{J-MAX-OP} = 125^{\circ}C$), the maximum power dissipation of the device in the application (P_{D-MAX}), and the junction-to ambient thermal resistance of the part/package in the application (θ_{JA}), as given by the following equation: $T_{A-MAX} = T_{J-MAX-OP} - (\theta_{JA} \times P_{D-MAX})$. The ambient temperature operating rating is provided merely for convenience. This part may be operated outside the listed T_A rating, so long as the junction temperature of the device does not exceed the maximum operating rating of 125°C.

THERMAL INFORMATION

Junction-to-Ambient Thermal	220°C/W
Resistance, VSSOP-8 Package (θ_{JA}) ⁽¹⁾	

- (1) Junction-to-ambient thermal resistance is a highly application and board-layout dependent. In applications where high maximum power dissipation exists, special care must be paid to thermal dissipation issues. For more information on these topics, please refer to the [POWER DISSIPATION](#) section of this datasheet.

ELECTRICAL CHARACTERISTICS⁽¹⁾⁽²⁾

Limits in standard typeface and typical values apply for $T_j = 25^\circ\text{C}$. Limits in **boldface** type apply over the operating junction temperature range. Unless otherwise specified: $2.6 \leq V_{IN} \leq 5.5\text{V}$, $V(\text{EN}) = V_{IN}$, $C_1 = C_2 = 1\mu\text{F}$, $C_{IN} = C_{OUT} = 10\mu\text{F}$.⁽³⁾

Symbol	Parameter	Conditions	Min	Typ	Max	Units
LM2788-1.8, LM2788-2.0						
V_{OUT}	Output Voltage Tolerance	$2.8\text{V} \leq V_{IN} \leq 4.2\text{V}$ $0\text{mA} \leq I_{OUT} \leq 120\text{mA}$	-5		+5	% of $V_{OUT(\text{nom})}$ ⁽⁴⁾
		$4.2\text{V} \leq V_{IN} \leq 5.5\text{V}$ $0\text{mA} \leq I_{OUT} \leq 120\text{mA}$	-6		+6	
LM2788-1.5						
V_{OUT}	Output Voltage Tolerance	$2.8\text{V} \leq V_{IN} \leq 4.2\text{V}$ $0\text{mA} \leq I_{OUT} \leq 120\text{mA}$	-6		+6	% of $V_{OUT(\text{nom})}$ ⁽⁴⁾
		$4.2\text{V} \leq V_{IN} \leq 5.5\text{V}$ $0\text{mA} \leq I_{OUT} \leq 120\text{mA}$	-6		+6	
All Output Voltage Options						
I_Q	Operating Supply Current	$I_{OUT} = 0\text{mA}$		32	50	μA
I_{SD}	Shutdown Supply Current	$V(\text{EN}) = 0\text{V}$		0.1	2	μA
V_R	Output Voltage Ripple	LM2788-1.8: $V_{IN} = 3.6\text{V}$, $I_{OUT} = 120\text{mA}$		20		$\text{mV}_{\text{p-p}}$
E_{PEAK}	Peak Efficiency	LM2788-1.8: $V_{IN} = 3.0\text{V}$, $I_{OUT} = 60\text{mA}$		90		%
E_{AVG}	Average Efficiency over Li-Ion Input Voltage Range ⁽⁵⁾	LM2788-1.5: $3.0 \leq V_{IN} \leq 4.2\text{V}$, $I_{OUT} = 60\text{mA}$		76		%
		LM2788-1.8: $3.0 \leq V_{IN} \leq 4.2\text{V}$, $I_{OUT} = 60\text{mA}$		82		
		LM2788-2.0: $3.0 \leq V_{IN} \leq 4.2\text{V}$, $I_{OUT} = 60\text{mA}$		75		
t_{ON}	Turn-On Time	$V_{IN} = 3.6\text{V}$, $I_{OUT} = 120\text{mA}$ ⁽⁶⁾		0.4		ms
f_{SW}	Switching Frequency			500		kHz
I_{SC}	Short-Circuit Current	$V_{IN} = 3.6$, $V_{OUT} = 0\text{V}$		25		mA
Enable Pin (EN) Characteristics						
V_{IH}	EN pin Logic-High Input		0.9		V_{IN}	V
V_{IL}	EN pin Logic-Low Input		0		0.4	V
I_{EN}	EN pin input current	$V_{\text{EN}} = 0\text{V}$		0		nA
		$V_{\text{EN}} = 5.5\text{V}$		30		

- (1) All voltages are with respect to the potential at the GND pin.
- (2) All room temperature limits are 100% tested or specified through statistical analysis. All limits at temperature extremes are specified by correlation using standard Statistical Quality Control methods (SQC). All limits are used to calculate Average Outgoing Quality Level (AOQL). Typical numbers are not ensured, but do represent the most likely norm.
- (3) C_{FLY} , C_{IN} , and C_{OUT} : Low-ESR Surface-Mount Ceramic Capacitors (MLCCs) used in setting electrical characteristics
- (4) Nominal output voltage ($V_{\text{OUT}(\text{nom})}$) is the target output voltage of the part, as given by the output-voltage-option identifier. See **Ordering Information** table for available options.
- (5) Efficiency is measured versus V_{IN} , with V_{IN} being swept in small increments from 3.0V to 4.2V. The average is calculated from these measurements results. Weighting to account for battery voltage discharge characteristics (V_{BAT} vs. Time) is not done in computing the average.
- (6) Turn-on time is measured from when the EN signal is pulled high until the output voltage crosses 90% of its final value.

BLOCK DIAGRAM

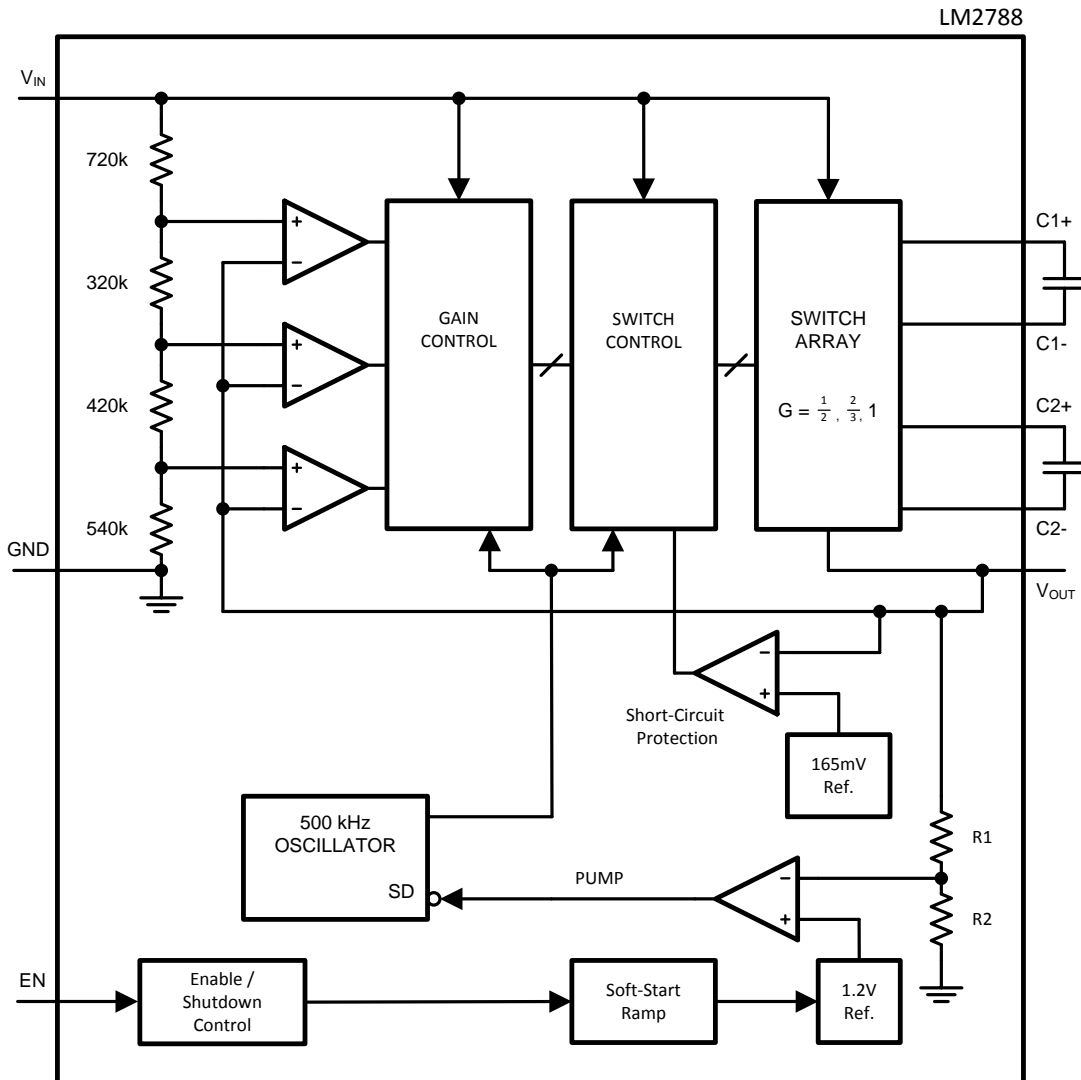

TYPICAL PERFORMANCE CHARACTERISTICS

Unless otherwise specified: $C_{IN} = 10\mu\text{F}$, $C_1 = 1.0\mu\text{F}$, $C_2 = 1.0\mu\text{F}$, $C_{OUT} = 10\mu\text{F}$, $T_A = 25^\circ\text{C}$. Capacitors are low-ESR multi-layer ceramic capacitors (MLCC's).

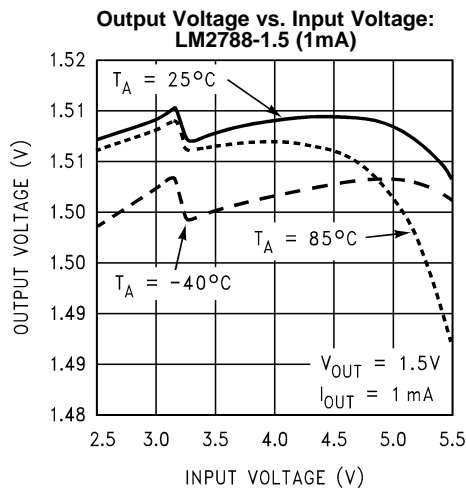

Figure 2.

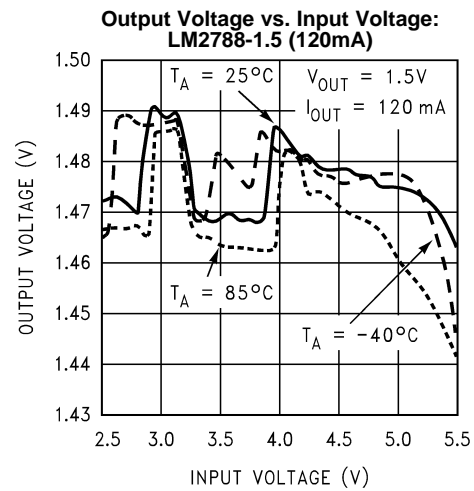

Figure 3.

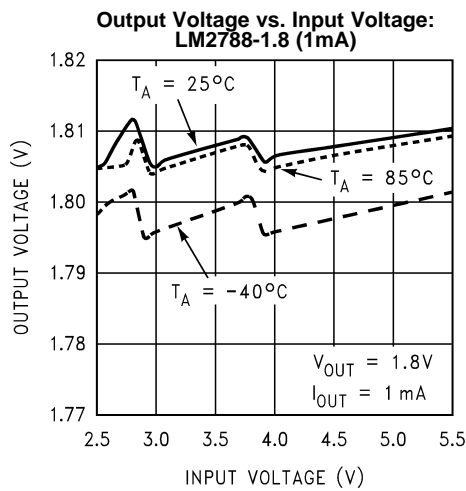

Figure 4.

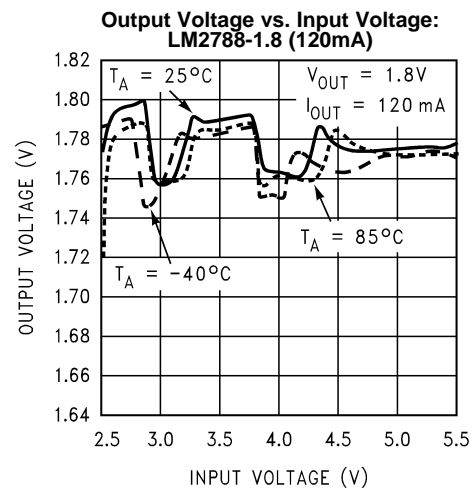

Figure 5.

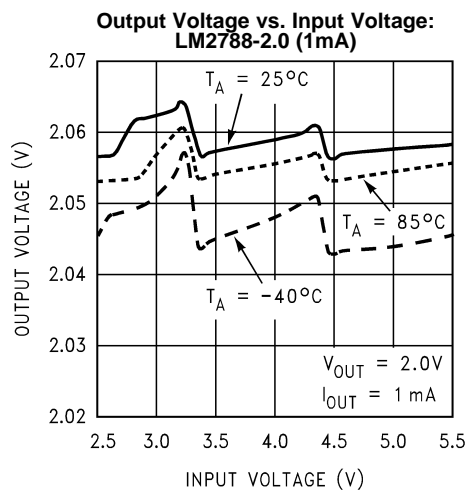

Figure 6.

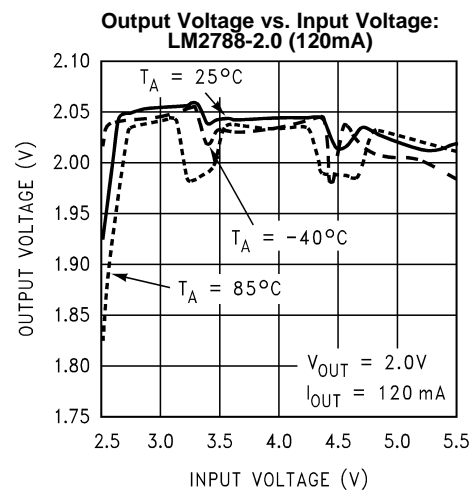

Figure 7.

TYPICAL PERFORMANCE CHARACTERISTICS (continued)

Unless otherwise specified: $C_{IN} = 10\mu F$, $C_1 = 1.0\mu F$, $C_2 = 1.0\mu F$, $C_{OUT} = 10\mu F$, $T_A = 25^\circ C$. Capacitors are low-ESR multi-layer ceramic capacitors (MLCC's).

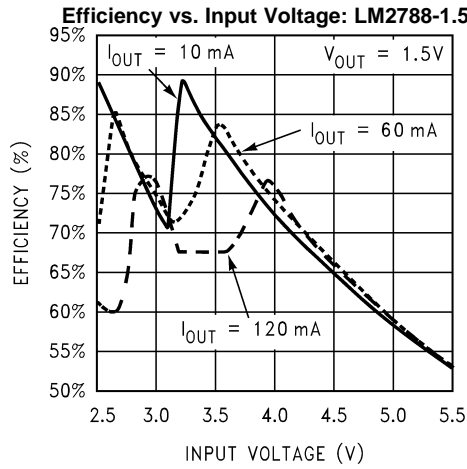

Figure 8.

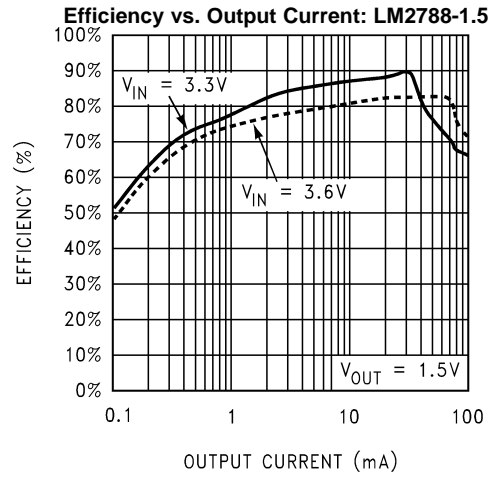

Figure 9.

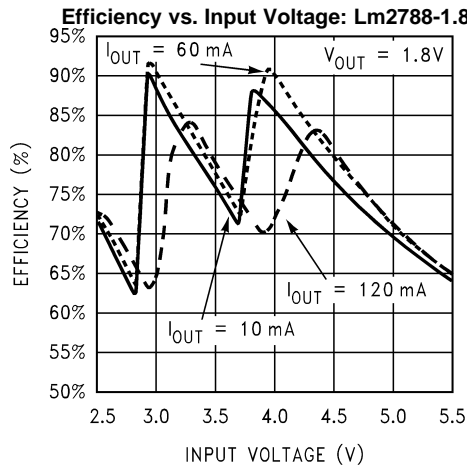

Figure 10.

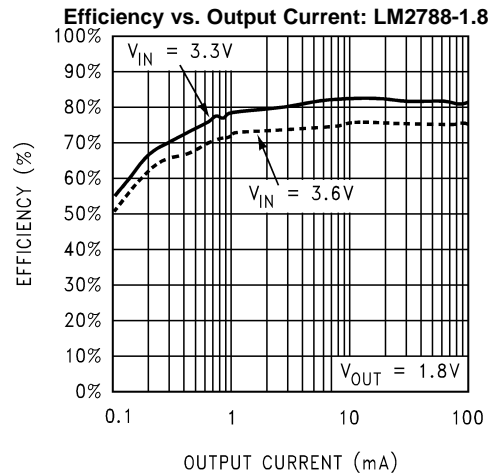

Figure 11.

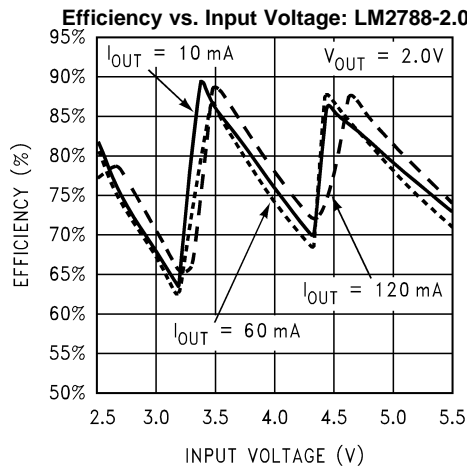

Figure 12.

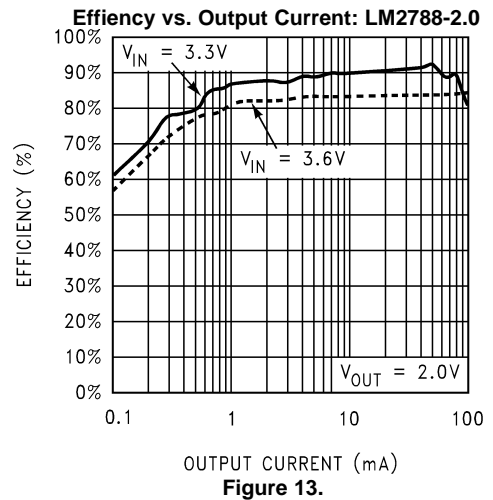

Figure 13.

TYPICAL PERFORMANCE CHARACTERISTICS (continued)

Unless otherwise specified: $C_{IN} = 10\mu F$, $C_1 = 1.0\mu F$, $C_2 = 1.0\mu F$, $C_{OUT} = 10\mu F$, $T_A = 25^\circ C$. Capacitors are low-ESR multi-layer ceramic capacitors (MLCC's).

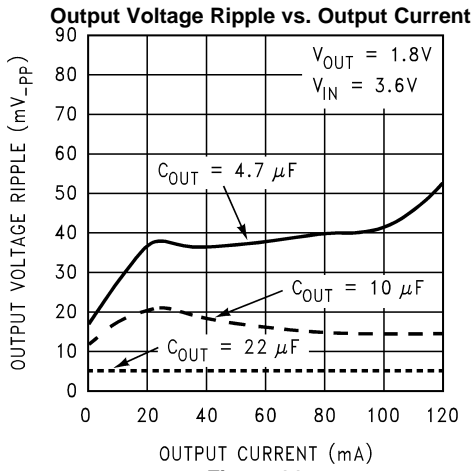

Figure 14.

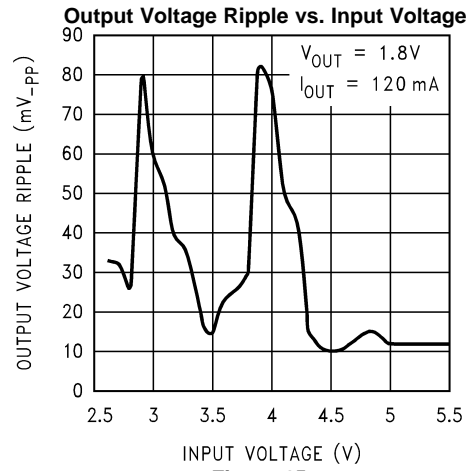

Figure 15.

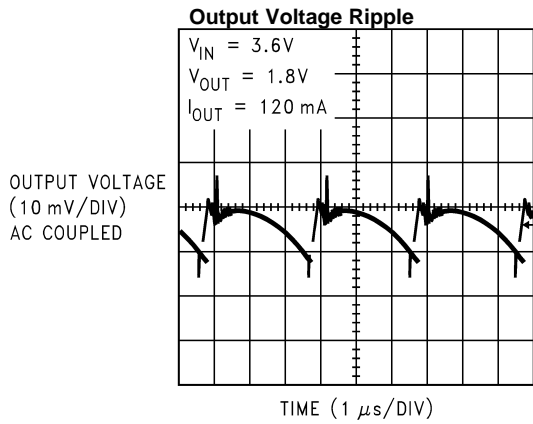

Figure 16.

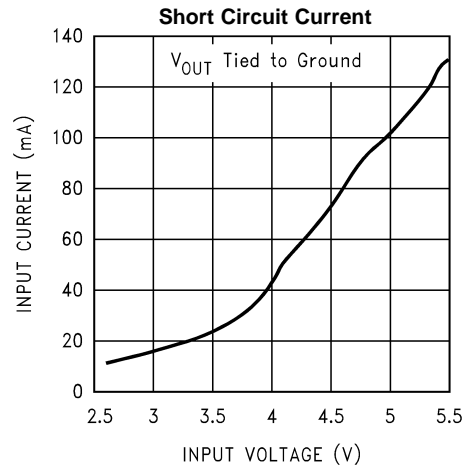

Figure 17.

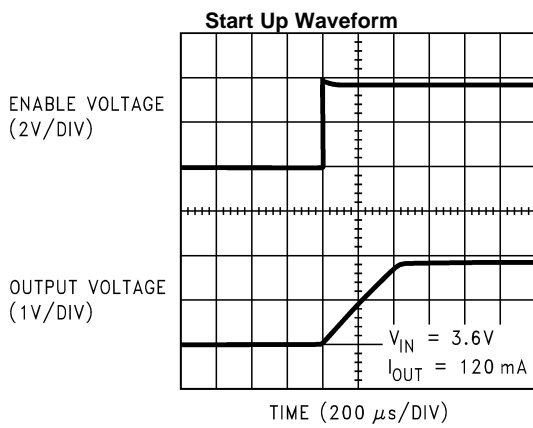

Figure 18.

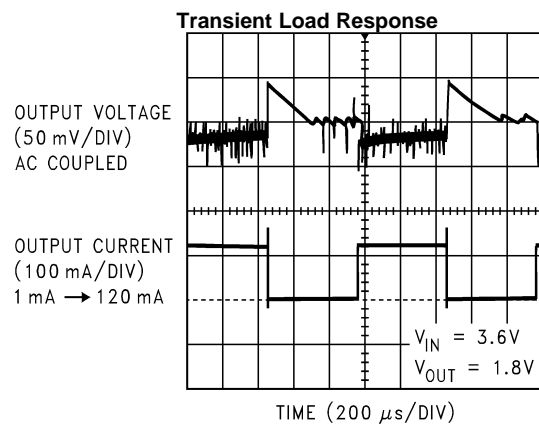

Figure 19.

OPERATION DESCRIPTION

OVERVIEW

The LM2788 is a switched capacitor converter that produces a regulated low-voltage output. The core of the part is the highly efficient charge pump that utilizes multiple fractional gains and pulse-frequency modulated (PFM) switching to minimize power losses over wide input voltage and output current ranges. A description of the principal operational characteristics of the LM2788 is broken up into the following sections: [PFM Regulation](#), [Fractional Multi-Gain Charge Pump](#), and [Gain Selection for Optimal Efficiency](#). Each of these sections refers to the [block diagram](#).

PFM REGULATION

The LM2788 achieves tightly regulated output voltages with pulse-frequency modulated (PFM) regulation. PFM simply means the part only pumps when it needs to. When the output voltage is above the target regulation voltage, the part idles and consumes minimal supply-current. In this state, the load current is supplied solely by the charge stored on the output capacitor. As this capacitor discharges and the output voltage falls below the target regulation voltage, the charge pump activates. Charge/current is delivered to the output (supplying the load and boosting the voltage on the output capacitor).

The primary benefit of PFM regulation is when output currents are light and the part is predominantly in the low-supply-current idle state. Net supply current is minimal because the part only occasionally needs to refresh the output capacitor by activating the charge pump, and the supply current it consumes.

FRACTIONAL MULTI-GAIN CHARGE PUMP

The core of the LM2788 is a two-phase charge pump controlled by an internally generated non-overlapping clock. The charge pump operates by using the external flying capacitors, C1 and C2, to transfer charge from the input to the output. During the charge phase, which doubles as the PFM "idle state", the flying capacitors are charged by the input supply. The charge pump will be in this state until the output voltage drops below the target regulation voltage, triggering the charge pump to activate so that it can deliver charge to the output. Charge transfer is achieved in the pump phase, where the fully charged flying capacitors are connected to the output so that the charge they hold can supply the load and recharge the output capacitor.

Input, output, and intermediary connections of the flying capacitors are made with internal MOS switches. The LM2788 utilizes two flying capacitors and a versatile switch network to achieve several fractional voltage gains: $\frac{1}{2}$, $\frac{2}{3}$, and 1. With this gain-switching ability, it is as if the LM2788 is three-charge-pumps-in-one. The "active" charge pump at any given time is the one that will yield the highest efficiency given the input and output conditions present.

GAIN SELECTION AND GAIN HOPPING FOR OPTIMAL EFFICIENCY

The ability to switch gains based on input and output conditions results in optimal LM2788 efficiency throughout the operating ranges of the part. Charge-pump efficiency is derived in the following two ideal equations (supply current and other losses are neglected for simplicity):

$$I_{IN} = G \times I_{OUT}$$

$$E = (V_{OUT} \times I_{OUT}) \div (V_{IN} \times I_{IN}) = V_{OUT} \div (G \times V_{IN})$$

In the equations, G represents the charge pump gain. Efficiency is optimal as $G \times V_{IN}$ approaches V_{OUT} . Optimal efficiency is achieved when gain is able to adjust depending on input and output voltage conditions. Due to the nature of charge pumps, G cannot adjust continuously, which would be ideal from an efficiency standpoint. But G can be a set of simple quantized ratios, allowing for a good degree of efficiency optimization.

The gain set of the LM2788 consists of the gains $\frac{1}{2}$, $\frac{2}{3}$, and 1. An internal input voltage range detector, along with the nominal output voltage of the given LM2788 option, determines what is to be referred to as the "base gain" of the part, G_B . The base gain is the default gain configuration of the part at a given V_{IN} . Table 1 lists G_B of the LM2788-1.8 over the input voltage range. (For the remainder of this discussion, the 1.8V option of the LM2788 will be used as an example. The other voltage options operate under the same principles as the 1.8V version, the gain-transitions merely occur at different voltage levels.)

Table 1. LM2788-1.8 Base Gain (G_B) vs. V_{IN}

Input Voltage	Base Gain (G_B)
2.6V - 2.9V	1
2.9V - 3.8V	$\frac{2}{3}$
3.8V - 5.5V	$\frac{1}{2}$

Table 1 shows the efficiency of the LM2788-1.8 versus input voltage, with output currents of 10mA and 120mA. The base gain regions (G_B) are separated and labeled. There is also a set of ideal efficiency gradients, $E_{IDEAL(G=xx)}$, showing the ideal efficiency of a charge pumps with gains of 1/2, 2/3, and 1. These curves were generated using the ideal efficiency equation presented above.

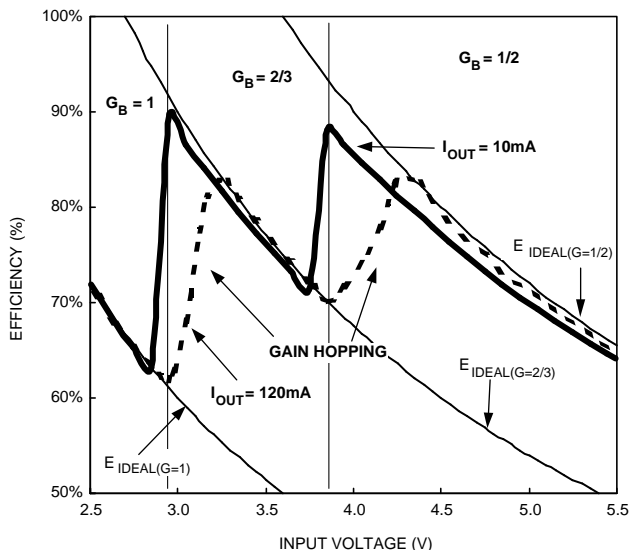

Base-gain (G_B) regions are separated and labeled. Ideal efficiency curves of charge pumps with $G = 1/2$, $2/3$, and 1 are included.

($E_{IDEAL(G=1)}$, $E_{IDEAL(G=2/3)}$, $E_{IDEAL(G=1/2)}$)

Figure 20. Efficiency of LM2788-1.8 with 10mA and 120mA output currents

The 10mA-load efficiency curve in **Figure 20** closely resembles the ideal Efficiency-vs.-Input-Voltage curves that correspond to each of the base-gain regions. The same holds true for the other base-gain regions. At the base-gain transitions ($V_{IN} = 2.9V, 3.8V$), the 10mA curve makes sharp transitions as the part switches base-gains. The 10mA load curve gives a clear picture of how base-gain affects overall converter efficiency. With a 10mA output current, the gain of the LM2788-1.8 is equal to the base-gain over the entire operating input voltage range. Additionally, with a 10mA load, internal supply current has a minimal impact on efficiency (Supply current does have a small effect: it is why the 10mA load curve is slightly below the ideal efficiency gradients in each of the base-gain regions).

The 120mA-load curve in **Figure 20** illustrates the effect of gain hopping on converter efficiency. Gain hopping is implemented to overcome output voltage droop that results from charge-pump non-idealities. In an ideal charge pump, the output voltage is equal to the product of the gain and the input voltage. Non-idealities such as finite switch resistance, capacitor ESR, and other factors result in the output of practical charge pumps being below the ideal value, however. This output droop is typically modeled as an output resistance, R_{OUT} , because the magnitude of the droop increases linearly with load current.

$$\text{Ideal Charge Pump: } V_{OUT} = G \times V_{IN}$$

$$\text{Real Charge Pump: } V_{OUT} = (G \times V_{IN}) - (I_{OUT} \times R_{OUT})$$

The LM2788 compensates for output voltage droop under high load conditions by gain hopping: when the base-gain is not sufficient to keep the output voltage in regulation, the part will temporarily switch up to the next highest gain setting to provide an intermittent boost in output voltage. When the output voltage is sufficiently boosted, the gain configuration reverts back to the base-gain setting. If the load remains high, the part will continue to hop back and forth between the base-gain and the next highest gain setting, and the output voltage will remain in regulation. In contrast to the base-gain decision, which is made based on the input voltage, the decision to gain hop is made by monitoring the voltage at the output of the part.

The efficiency curve of the LM2788-1.8 with a 120mA output current, also contained in [Figure 20](#), shows the effect that gain hopping has on efficiency. Comparing the 120mA load curve to the 10mA load curve, it is plain to see that to the right of the base-gain transitions, the efficiency of the 120mA curve increases gradually whereas the 10mA curve makes a sharp transition. The base-gain of both curves is the same for both loads. The difference comes in gain hopping. With the 120mA load, the part will spend a percentage of time in the base-gain setting and the rest of the time in the next-highest gain setting. The percentage of time gain hopping decreases as the input voltage rises, as less gain-hopping boost is required with increased input voltage. When the input voltage in a given base-gain region is large enough so that no extra boost from gain hopping is required, the 120mA-load efficiency curve mirrors the 10mA efficiency curve.

Table 2. LM2788-1.8 Gain Hopping Regions

Input Voltage	Base Gain (G_B)	Gain Hop Setting
3.0V - 3.3V	$\frac{2}{3}$	1
3.8V - 4.4V	$\frac{1}{2}$	$\frac{2}{3}$

Gain hopping contributes to the overall high efficiency of the LM2788. Gain hopping only occurs when required for keeping the output voltage in regulation. This allows the LM2788 to operate in the higher efficiency base-gain setting as much as possible. Gain hopping also allows the base-gain transitions to be placed at input voltages that are as low as practically possible. This maximizes the peaks, and minimizes the valleys, of the efficiency "saw-tooth" curves, again maximizing total solution efficiency.

SHUTDOWN

The LM2788 is in shutdown mode when the voltage on the active-low logic enable pin (EN) is low. In shutdown, the LM2788 draws virtually no supply current. When in shutdown, the output of the LM2788 is completely disconnected from the input, and will be 0V unless driven by an outside source.

In some applications, it may be desired to disable the LM2788 and drive the output pin with another voltage source. This can be done, but the voltage on the output pin of the LM2788 must not be brought above the input voltage. The output pin will draw a small amount when driven externally due the internal feedback resistor divider connected between V_{OUT} and GND.

SOFT START

The LM2788 employs soft start circuitry to prevent excessive input inrush currents during startup. The output voltage is programmed to rise from 0V to the nominal output voltage in approximately 400 μ s (typ.). With the input voltage established, soft-start is engaged when a part is enabled by pulling the voltage on the EN pin high. Soft-start also engages when voltage is established simultaneously to the V_{IN} and EN pins

THERMAL SHUTDOWN

Protection from overheating-related damage is achieved with a thermal shutdown feature. When the junction temperature rises to 150°C (typ.), the part switches into shutdown mode. The LM2788 disengages thermal shutdown when the junction temperature of the part is reduced to 130°C (typ.). Due to its high efficiency, the LM2788 should not activate thermal shutdown (or exhibit related thermal cycling) when the part is operated within specified input voltage, output current, and ambient temperature operating ratings.

SHORT-CIRCUIT PROTECTION

The LM2788 short-circuit protection circuitry that protects the device in the event of excessive output current and/or output shorts to ground. A graph of "Short-Circuit Current vs. Input Voltage" is provided in the [Typical Performance Characteristics](#) section.

APPLICATION INFORMATION

OUTPUT VOLTAGE RIPPLE

The voltage ripple on the output of the LM2788 is highly dependent on the application conditions. The output capacitor, the input voltage, and the output current each play a significant part in determining the output voltage ripple. Due to the complexity of LM2788 operation, providing equations or models to approximate the magnitude of the ripple cannot be easily accomplished. The following general statements can be made however

The output capacitor will have a significant effect on output voltage ripple magnitude. Ripple magnitude will typically be linearly proportional to the output capacitance present. A low-ESR ceramic capacitor is recommended on the output to keep output voltage ripple low. Placing multiple capacitors in parallel can reduce ripple significantly, both by increasing capacitance and reducing ESR. When capacitors are in parallel, ESR is in parallel as well. The effective net ESR is determined according to the properties of parallel resistance. Two identical capacitors in parallel have twice the capacitance and half the ESR as compared to a single capacitor of the same make. On a similar note, if a large-value, high-ESR capacitor (tantalum, for example) is to be used as the primary output capacitor, the net output ESR can be significantly reduced by placing a low-ESR ceramic capacitor in parallel with this primary output capacitor.

Ripple is increased when the LM2788 is gain hopping. Thus, in the presence of high currents, ripple is likely to vary significantly over the input voltage, depending on whether or not the part is gain hopping.

CAPACITORS

The LM2788 requires 4 external capacitors for proper operation. Surface-mount multi-layer ceramic capacitors are recommended. These capacitors are small, inexpensive and have very low equivalent series resistance (ESR, $\leq 15\text{m}\Omega$ typ.). Tantalum capacitors, OS-CON capacitors, and aluminum electrolytic capacitors generally are not recommended for use with the LM2788 due to their high ESR, as compared to ceramic capacitors.

For most applications, ceramic capacitors with X7R or X5R temperature characteristic are preferred for use with the LM2788. These capacitors have tight capacitance tolerance (as good as $\pm 10\%$), hold their value over temperature (X7R: $\pm 15\%$ over -55°C to 125°C ; X5R: $\pm 15\%$ over -55°C to 85°C), and typically have little voltage coefficient.

Capacitors with Y5V and/or Z5U temperature characteristic are generally not recommended for use with the LM2788. These types of capacitors typically have wide capacitance tolerance ($+80\%$, -20%), vary significantly over temperature (Y5V: $+22\%$, -82% over -30°C to $+85^\circ\text{C}$ range; Z5U: $+22\%$, -56% over $+10^\circ\text{C}$ to $+85^\circ\text{C}$ range), and have poor voltage coefficients. Under some conditions, a nominal $1\mu\text{F}$ Y5V or Z5U capacitor could have a capacitance of only $0.1\mu\text{F}$. Such detrimental deviation is likely to cause these Y5V and Z5U of capacitors to fail to meet the minimum capacitance requirements of the LM2788.

The table below lists some leading ceramic capacitor manufacturers.

Manufacturer	Contact Information
AVX	www.avx.com
Murata	www.murata.com
Taiyo-Yuden	www.t-yuden.com
TDK	www.component.tdk.com
Vishay-Vitramon	www.vishay.com

OUTPUT CAPACITOR

The output capacitor of the LM2788 plays an important part in LM2788 performance. In typical high-current applications, a $10\mu\text{F}$ low-ESR (ESR = equivalent series resistance) ceramic capacitor is recommended for use. For lighter loads, the output capacitance may be reduced (capacitance as low as $1\mu\text{F}$ for output currents $\leq 60\text{mA}$ is usually acceptable). The performance of the part should be evaluated with special attention paid to efficiency and output ripple to ensure the capacitance chosen on the output yields performance suitable for the application. In extreme cases, excessive ripple could cause control loop instability, severely affecting the performance of the part. If excessive ripple is present, the output capacitance should be increased.

The ESR of the output capacitor affects charge pump output resistance, which plays a role in determining output current capability. Both output capacitance and ESR affect output voltage ripple (See [Output Voltage Ripple](#) section, above). For these reasons, a low-ESR X7R/X5R ceramic capacitor is the capacitor of choice for the LM2788 output.

FLYING CAPACITORS

The flying capacitors (C_1 and C_2) transfer charge from the input to the output, and thus are like the engine of the charge pump. Low-ESR ceramic capacitors with X7R or X5R temperature characteristic are strongly recommended for use here. The flying capacitors C_1 and C_2 should be identical. As a general rule, the capacitance value of each flying capacitor should be 1/10th that of the output capacitor. Polarized capacitor (tantalum, aluminum electrolytic, etc.) must not be used for the flying capacitors, as they could become reverse-biased upon start-up of the LM2788.

The flying capacitance determines the strength of the charge pump—the larger the capacitance, the bigger the engine. ESR in the flying capacitors negatively affects the strength of the charge pump and should be minimized, as ESR contributes to undesired output resistance. If capacitors are too small the LM2788 could spend excessive amount of time gain hopping: decreasing efficiency, increasing output voltage ripple, and possibly impeding the ability of the part to regulate. On the other hand, if the flying capacitors are too large they could potentially overwhelm the output capacitor, resulting in increased output voltage ripple.

INPUT CAPACITOR

If the flying capacitors are the charge pump engine, the input capacitor (C_{IN}) is the fuel tank: a reservoir of charge that aids a quick transfer of charge from the supply to the flying capacitors during the charge phase of operation. The input capacitor helps to keep the input voltage from drooping at the start of the charge phase, when the flying capacitor is first connected to the input, and helps to filter noise on the input pin that could adversely affect sensitive internal analog circuitry biased off the input line. As mentioned above, an X7R/X5R ceramic capacitor is recommended for use. As a general recommendation, the input capacitor should be chosen to match the output capacitor.

POWER DISSIPATION

LM2788 power dissipation will, typically, not be much of a concern in most applications. Derating to accommodate self-heating will rarely be required due to the high efficiency of the part. When operating within specified operating ratings, the peak power dissipation (PD) of all LM2788 voltage options occurs with the LM2788-1.5 operating at the maximum rated operating output current of 120mA. With an input voltage of 5.5V, the power efficiency (E) of the LM2788-1.5 bottoms out at 54%. Assuming a typical junction-to-ambient thermal resistance (θ_{JA}) for the VSSOP package of 220°C/Watt, the junction temperature (T_J) of the part is calculated below for a part operating at the maximum rated ambient temperature (T_A) of 85°C.

$$\begin{aligned} P_D &= P_{IN} - P_{OUT} \\ &= (P_{OUT} / E) - P_{OUT} \\ &= [(1/E) - 1] \times P_{OUT} \\ &= [(1/54\%) - 1] \times 1.5V \times 120mW \\ &= 153mW \end{aligned}$$

$$\begin{aligned} T_J &= T_A + (P_D \times \theta_{JA}) \\ &= 85^\circ\text{C} + (.153W \times 220^\circ\text{C}/W) \\ &= 119^\circ\text{C} \end{aligned}$$

Even under these peak power dissipation and ambient temperature conditions, the junction temperature of the LM2788 is below the maximum operating rating of 125°C.

As an additional note, the ambient temperature operating rating range listed in the specifications is provided merely for convenience. The LM2788 may be operated outside this rating, so long as the junction temperature of the device does not exceed the maximum operating rating of 125°C.

Layout Guidelines

Proper board layout to accommodate the LM2788 circuit will help to ensure optimal performance. The following guidelines are recommended:

- Place capacitors as close to the LM2788 as possible, and preferably on the same side of the board as the IC.
- Use short, wide traces to connect the external capacitors to the LM2788 to minimize trace resistance and inductance.
- Use a low resistance connection between ground and the GND pin of the LM2788. Using wide traces and/or multiple vias to connect GND to a ground plane on the board is most advantageous.

Figure 21 is a sample single-layer board layout that accommodates the LM2788 typical application circuit, as pictured on the cover of this datasheet

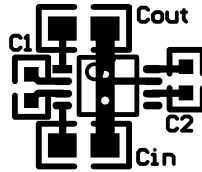

(Vias to a ground plane, assumed to be present, are located in the center of the LM2788 footprint.)

Figure 21. Sample single-layer board layout of the LM2788 Typical Application Circuit

REVISION HISTORY

Changes from Revision B (April 2013) to Revision C	Page
• Changed layout of National Data Sheet to TI format	14

IMPORTANT NOTICE

Texas Instruments Incorporated and its subsidiaries (TI) reserve the right to make corrections, enhancements, improvements and other changes to its semiconductor products and services per JESD46, latest issue, and to discontinue any product or service per JESD48, latest issue. Buyers should obtain the latest relevant information before placing orders and should verify that such information is current and complete. All semiconductor products (also referred to herein as "components") are sold subject to TI's terms and conditions of sale supplied at the time of order acknowledgment.

TI warrants performance of its components to the specifications applicable at the time of sale, in accordance with the warranty in TI's terms and conditions of sale of semiconductor products. Testing and other quality control techniques are used to the extent TI deems necessary to support this warranty. Except where mandated by applicable law, testing of all parameters of each component is not necessarily performed.

TI assumes no liability for applications assistance or the design of Buyers' products. Buyers are responsible for their products and applications using TI components. To minimize the risks associated with Buyers' products and applications, Buyers should provide adequate design and operating safeguards.

TI does not warrant or represent that any license, either express or implied, is granted under any patent right, copyright, mask work right, or other intellectual property right relating to any combination, machine, or process in which TI components or services are used. Information published by TI regarding third-party products or services does not constitute a license to use such products or services or a warranty or endorsement thereof. Use of such information may require a license from a third party under the patents or other intellectual property of the third party, or a license from TI under the patents or other intellectual property of TI.

Reproduction of significant portions of TI information in TI data books or data sheets is permissible only if reproduction is without alteration and is accompanied by all associated warranties, conditions, limitations, and notices. TI is not responsible or liable for such altered documentation. Information of third parties may be subject to additional restrictions.

Resale of TI components or services with statements different from or beyond the parameters stated by TI for that component or service voids all express and any implied warranties for the associated TI component or service and is an unfair and deceptive business practice. TI is not responsible or liable for any such statements.

Buyer acknowledges and agrees that it is solely responsible for compliance with all legal, regulatory and safety-related requirements concerning its products, and any use of TI components in its applications, notwithstanding any applications-related information or support that may be provided by TI. Buyer represents and agrees that it has all the necessary expertise to create and implement safeguards which anticipate dangerous consequences of failures, monitor failures and their consequences, lessen the likelihood of failures that might cause harm and take appropriate remedial actions. Buyer will fully indemnify TI and its representatives against any damages arising out of the use of any TI components in safety-critical applications.

In some cases, TI components may be promoted specifically to facilitate safety-related applications. With such components, TI's goal is to help enable customers to design and create their own end-product solutions that meet applicable functional safety standards and requirements. Nonetheless, such components are subject to these terms.

No TI components are authorized for use in FDA Class III (or similar life-critical medical equipment) unless authorized officers of the parties have executed a special agreement specifically governing such use.

Only those TI components which TI has specifically designated as military grade or "enhanced plastic" are designed and intended for use in military/aerospace applications or environments. Buyer acknowledges and agrees that any military or aerospace use of TI components which have **not** been so designated is solely at the Buyer's risk, and that Buyer is solely responsible for compliance with all legal and regulatory requirements in connection with such use.

TI has specifically designated certain components as meeting ISO/TS16949 requirements, mainly for automotive use. In any case of use of non-designated products, TI will not be responsible for any failure to meet ISO/TS16949.

Products

Audio	www.ti.com/audio
Amplifiers	amplifier.ti.com
Data Converters	dataconverter.ti.com
DLP® Products	www.dlp.com
DSP	dsp.ti.com
Clocks and Timers	www.ti.com/clocks
Interface	interface.ti.com
Logic	logic.ti.com
Power Mgmt	power.ti.com
Microcontrollers	microcontroller.ti.com
RFID	www.ti-rfid.com
OMAP Applications Processors	www.ti.com/omap
Wireless Connectivity	www.ti.com/wirelessconnectivity

Applications



Automotive and Transportation	www.ti.com/automotive
Communications and Telecom	www.ti.com/communications
Computers and Peripherals	www.ti.com/computers
Consumer Electronics	www.ti.com/consumer-apps
Energy and Lighting	www.ti.com/energy
Industrial	www.ti.com/industrial
Medical	www.ti.com/medical
Security	www.ti.com/security
Space, Avionics and Defense	www.ti.com/space-avionics-defense
Video and Imaging	www.ti.com/video

TI E2E Community

e2e.ti.com

Looking for pricing, stock, or lifecycle information?

Click below to explore more details on WIN SOURCE:

-  [View LM2788MM-1.8/NOPB on WIN SOURCE](#)
-  [Texas Instruments](#) Information

Optimize Your Supply Chain with WIN SOURCE Solutions

-  Global Sourcing Solution
-  Obsolete Management
-  Cost Control Management
-  Shortage Management
-  Alternative Solution
-  Excess Inventory Management