



**THE DATASHEET OF  
LM2842YMKX-ADJL**



## LM284x SIMPLE SWITCHER<sup>®</sup> 4.5-V to 42-V Input, 0.1-, 0.3-, or 0.6-A Output Step-Down DC/DC Regulator in Thin SOT

### 1 Features

- Input voltage 4.5 V to 42 V
- Output current options of 100 mA, 300 mA, and 600 mA
- Feedback pin voltage of 0.765 V
- 550-kHz (X) or 1.25-MHz (Y) switching frequency
- Low shutdown  $I_Q$ : 16- $\mu$ A typical
- Short-circuit protected
- Internally compensated
- Soft-start circuitry
- Small overall solution size (SOT-6L package)
- Create a custom design using the LM2840 (or LM2841/42) with the [WEBENCH<sup>®</sup> Power Designer](#)

### 2 Applications

- Battery-powered equipment
- Industrial distributed power applications
- Portable media players
- Portable hand-held instruments

### 3 Description

The LM284x SIMPLE SWITCHER<sup>™</sup> devices are PWM DC/DC buck (step-down) regulators. With an input range from 4.5 V to 42 V, they are suitable for a wide range of applications, such as power conditioning from unregulated sources. They feature a low  $R_{DS(ON)}$  (0.9- $\Omega$  typical) internal switch for maximum efficiency (85% typical). Operating frequency is fixed at 550 kHz (X option) and 1.25 MHz (Y option), allowing the use of small external components while still being able to have low output voltage ripple. Soft start can be implemented using the shutdown ( $\overline{SHDN}$ ) pin with an external RC circuit allowing the user to tailor the soft-start time to a specific application.

The LM2840 is optimized for up to 100 mA, the LM2841 for up to 300 mA, and the LM2842 for up to 600-mA load currents. They all have a 0.765-V nominal feedback voltage.

Additional features include: thermal shutdown,  $V_{IN}$  undervoltage lockout, and gate-drive undervoltage lockout. The LM284x are available in a low-profile SOT-6L package.

#### Device Information<sup>(1)</sup>

PART NUMBER	PACKAGE	BODY SIZE (NOM)
LM2840, LM2841, LM2842	SOT (6)	1.60 mm x 2.90 mm

(1) For all available packages, see the orderable addendum at the end of the data sheet.

#### Typical Application Circuit

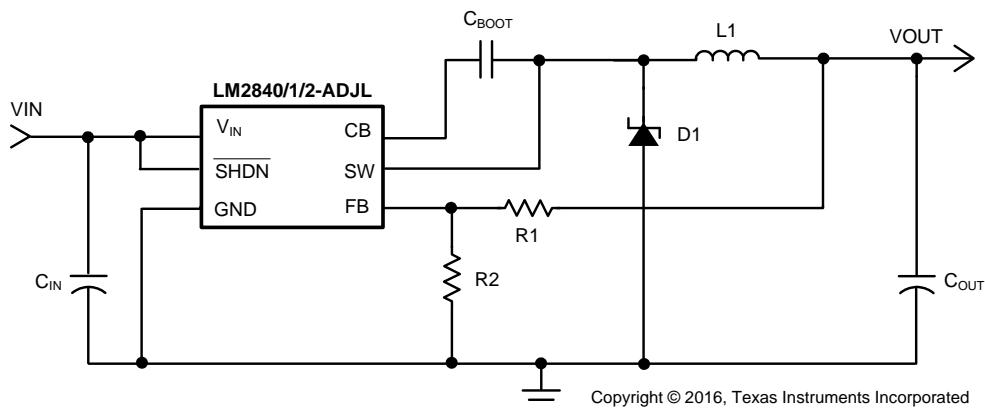

## Table of Contents

<b>1</b>	<b>Features</b> .....	<b>1</b>	<b>8</b>	<b>Application and Implementation</b> .....	<b>11</b>
<b>2</b>	<b>Applications</b> .....	<b>1</b>	8.1	Application Information.....	11
<b>3</b>	<b>Description</b> .....	<b>1</b>	8.2	Typical Applications .....	11
<b>4</b>	<b>Revision History</b> .....	<b>2</b>	<b>9</b>	<b>Power Supply Recommendations</b> .....	<b>16</b>
<b>5</b>	<b>Pin Configuration and Functions</b> .....	<b>3</b>	<b>10</b>	<b>Layout</b> .....	<b>16</b>
<b>6</b>	<b>Specifications</b> .....	<b>4</b>	10.1	Layout Guidelines .....	16
6.1	Absolute Maximum Ratings .....	4	10.2	Layout Example .....	16
6.2	ESD Ratings.....	4	<b>11</b>	<b>Device and Documentation Support</b> .....	<b>17</b>
6.3	Recommended Operating Conditions.....	4	11.1	Device Support.....	17
6.4	Thermal Information .....	4	11.2	Documentation Support .....	17
6.5	Electrical Characteristics .....	5	11.3	Related Links .....	17
6.6	Typical Characteristics.....	7	11.4	Receiving Notification of Documentation Updates	17
<b>7</b>	<b>Detailed Description</b> .....	<b>9</b>	11.5	Community Resources.....	18
7.1	Overview .....	9	11.6	Trademarks .....	18
7.2	Functional Block Diagram .....	9	11.7	Electrostatic Discharge Caution.....	18
7.3	Feature Description.....	9	11.8	Glossary .....	18
7.4	Device Functional Modes.....	10	<b>12</b>	<b>Mechanical, Packaging, and Orderable Information</b> .....	<b>18</b>

## 4 Revision History

NOTE: Page numbers for previous revisions may differ from page numbers in the current version.

<b>Changes from Revision J (February 2017) to Revision K</b>	<b>Page</b>
• Split automotive data sheet to separate document (SNVSBE5) and remove automotive-specific content from SNVS540 ..	1
• Added SIMPLE SWITCHER® to data sheet title .....	1

---

<b>Changes from Revision I (September 2016) to Revision J</b>	<b>Page</b>
• Added new text for Pin 4 .....	3
• Added this new line of text in Shutdown Operation section .....	13

---

<b>Changes from Revision H (April 2013) to Revision I</b>	<b>Page</b>
• Added <i>ESD Ratings</i> table, <i>Feature Description</i> section, <i>Device Functional Modes</i> , <i>Application and Implementation</i> section, <i>Power Supply Recommendations</i> section, <i>Layout</i> section, <i>Device and Documentation Support</i> section, and <i>Mechanical, Packaging, and Orderable Information</i> section. ....	1
• Added <i>Thermal Information</i> table .....	4

---

<b>Changes from Revision G (April 2013) to Revision H</b>	<b>Page</b>
• Changed layout of National Semiconductor data sheet to TI format.....	1

## 5 Pin Configuration and Functions

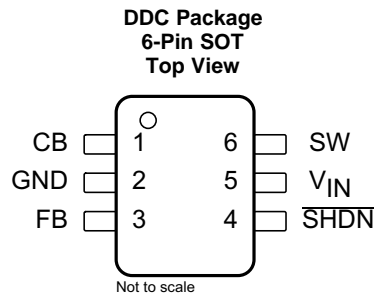

### Pin Functions

PIN		I/O	DESCRIPTION
NO.	NAME		
1	CB	I	SW FET gate bias voltage. Connect $C_{BOOT}$ capacitor between CB and SW.
2	GND	—	Ground connection
3	FB	I	Feedback pin: Set feedback voltage divider ratio with $V_{OUT} = V_{FB} (1 + (R1 / R2))$ . Resistors must be from 100 $\Omega$ to 10 k $\Omega$ to avoid input bias errors.
4	$\overline{\text{SHDN}}$	I	Logic level shutdown input. Pull to GND to disable the device and pull high to enable the device. If this function is not used tie to $V_{IN}$ . DO NOT ALLOW TO FLOAT.
5	$V_{IN}$	I	Power input voltage pin: 4.5-V to 42-V normal operating range.
6	SW	O	Power FET output: Connect to inductor, diode, and $C_{BOOT}$ capacitor.

## 6 Specifications

### 6.1 Absolute Maximum Ratings

 See <sup>(1)(2)</sup>

	MIN	MAX	UNIT
$V_{IN}$	-0.3	45	V
$\overline{SHDN}$	-0.3	$(V_{IN} + 0.3 \text{ V}) < 45$	V
SW voltage	-0.3	45	V
CB voltage above SW voltage		7	V
FB voltage	-0.3	5	V
Power dissipation <sup>(3)</sup>	Internally Limited		
Maximum junction temperature		150	°C
Storage temperature, $T_{stg}$	-65	150	°C

- Stresses beyond those listed under *Absolute Maximum Ratings* may cause permanent damage to the device. These are stress ratings only, which do not imply functional operation of the device at these or any other conditions beyond those indicated under *Recommended Operating Conditions*. Exposure to absolute-maximum-rated conditions for extended periods may affect device reliability.
- If Military/Aerospace specified devices are required, contact the Texas Instruments Sales Office/Distributors for availability and specifications.
- The maximum allowable power dissipation is a function of the maximum junction temperature,  $T_{J(MAX)}$ , the junction-to-ambient thermal resistance,  $R_{\theta JA}$ , and the ambient temperature,  $T_A$ . The maximum allowable power dissipation at any ambient temperature is calculated using:  $P_D (MAX) = (T_{J(MAX)} - T_A) / R_{\theta JA}$ . Exceeding the maximum allowable power dissipation causes excessive die temperature, and the regulator goes into thermal shutdown. Internal thermal shutdown circuitry protects the device from permanent damage. Thermal shutdown engages at  $T_J=175^\circ\text{C}$  (typical) and disengages at  $T_J= 155^\circ\text{C}$  (typical).

### 6.2 ESD Ratings

	VALUE	UNIT
$V_{(ESD)}$ Electrostatic discharge Human-body model (HBM), per ANSI/ESDA/JEDEC JS-001 <sup>(1)</sup>	±2000	V

- JEDEC document JEP155 states that 500-V HBM allows safe manufacturing with a standard ESD control process.

### 6.3 Recommended Operating Conditions

over operating free-air temperature range (unless otherwise noted)

	MIN	MAX	UNIT
Operating junction temperature <sup>(1)</sup>	-40	125	°C
Input voltage $V_{IN}$	4.5	42	V
SW voltage		42	V

- All limits specified at room temperature ( $T_A = 25^\circ\text{C}$ ) unless otherwise specified. All room temperature limits are 100% production tested. All limits at temperature extremes are ensured through correlation using standard Statistical Quality Control (SQC) methods. All limits are used to calculate Average Outgoing Quality Level (AOQL).

### 6.4 Thermal Information

THERMAL METRIC <sup>(1)</sup>		LM284x	UNIT
		DDC (SOT)	
		6 PINS	
$R_{\theta JA}$	Junction-to-ambient thermal resistance <sup>(2)(3)</sup>	121	°C/W
$R_{\theta JC(top)}$	Junction-to-case (top) thermal resistance	94	°C/W

- For more information about traditional and new thermal metrics, see the *Semiconductor and IC Package Thermal Metrics* application report.
- The package thermal impedance is calculated in accordance to JESD 51-7.
- Thermal Resistances were simulated on a 4-layer, JEDEC board

## 6.5 Electrical Characteristics

Specifications are for  $T_J = 25^\circ\text{C}$  unless otherwise specified. Minimum and Maximum limits are specified through test, design, or statistical correlation. Typical values represent the most likely parametric norm at  $T_J = 25^\circ\text{C}$ , and are provided for reference purposes only. Unless otherwise stated the following conditions apply:  $V_{IN} = 12\text{ V}$ .<sup>(1)(2)(3)</sup>

PARAMETER		TEST CONDITIONS		MIN	TYP	MAX	UNIT	
$I_Q$	Quiescent current	$\overline{\text{SHDN}} = 0\text{ V}$			16		$\mu\text{A}$	
			$T_J = -40^\circ\text{C}$ to $125^\circ\text{C}$			40		
		Device ON, not switching				1.3		mA
			$T_J = -40^\circ\text{C}$ to $125^\circ\text{C}$				1.75	
Device ON, no load				1.35		mA		
$T_J = -40^\circ\text{C}$ to $125^\circ\text{C}$					1.85			
$R_{\text{DS(ON)}}$	Switch ON resistance	See <sup>(4)</sup>			0.9		$\Omega$	
			$T_J = -40^\circ\text{C}$ to $125^\circ\text{C}$					1.6
$I_{\text{LSW}}$	Switch leakage current	$V_{\text{IN}} = 42\text{ V}$			0		$\mu\text{A}$	
			$T_J = -40^\circ\text{C}$ to $125^\circ\text{C}$					0.5
$I_{\text{CL}}$	Switch current limit	LM2840 <sup>(5)</sup>			525		mA	
			$T_J = -40^\circ\text{C}$ to $125^\circ\text{C}$					900
		LM2841 <sup>(5)</sup>				525		mA
			$T_J = -40^\circ\text{C}$ to $125^\circ\text{C}$				900	
		LM2842 <sup>(5)</sup>				1.15		A
			$T_J = -40^\circ\text{C}$ to $125^\circ\text{C}$				1.7	
$I_{\text{FB}}$	Feedback pin bias current	LM284[0,1,2] <sup>(6)</sup>			0.1		$\mu\text{A}$	
			$T_J = -40^\circ\text{C}$ to $125^\circ\text{C}$					1
$V_{\text{FB}}$	FB Pin reference voltage				0.765		V	
		$T_J = -40^\circ\text{C}$ to $125^\circ\text{C}$			0.747			0.782
$t_{\text{ON(min)}}$	Minimum ON-time	See <sup>(7)</sup>			100		ns	
			$T_J = -40^\circ\text{C}$ to $125^\circ\text{C}$					150
$t_{\text{OFF(min)}}$	Minimum OFF-time	X option			110		ns	
			$T_J = -40^\circ\text{C}$ to $125^\circ\text{C}$					370
		Y option				104		ns
			$T_J = -40^\circ\text{C}$ to $125^\circ\text{C}$				200	
$f_{\text{SW}}$	Switching frequency	X option, $V_{\text{FB}} = 0.5\text{ V}$			550		kHz	
			$T_J = -40^\circ\text{C}$ to $125^\circ\text{C}$			325		
		X option, $V_{\text{FB}} = 0\text{ V}$				140		MHz
			$T_J = -40^\circ\text{C}$ to $125^\circ\text{C}$				1.25	
		Y option, $V_{\text{FB}} = 0.5\text{ V}$				0.95		MHz
			$T_J = -40^\circ\text{C}$ to $125^\circ\text{C}$				1.5	
Y option, $V_{\text{FB}} = 0\text{ V}$				0.35		MHz		
	$T_J = -40^\circ\text{C}$ to $125^\circ\text{C}$				0.35			
$D_{\text{MAX}}$	Maximum duty cycle	X option			94%			
			$T_J = -40^\circ\text{C}$ to $125^\circ\text{C}$			88%		
		Y option				87%		
			$T_J = -40^\circ\text{C}$ to $125^\circ\text{C}$			81%		

(1) All limits specified at room temperature ( $T_A = 25^\circ\text{C}$ ) unless otherwise noted. Room temperature limits are production tested. Limits at temperature extremes are ensured through correlation using standard Statistical Quality Control (SQC) methods. Limits are used to calculate Average Outgoing Quality Level (AOQL).

(2) Typical numbers are at  $25^\circ\text{C}$  and represent the most likely norm.

(3) The part numbers in this table represent both the Q1 and non-Q1 versions of the respective parts.

(4) Includes the bond wires,  $R_{\text{DS(ON)}}$  from  $V_{\text{IN}}$  pin to SW pin.

(5) Current limit at 0% duty cycle. May be lower at higher duty cycle or input voltages below 6 V.

(6) Bias currents flow into pin.

(7) Minimum ON-time specified by design and simulation.

## Electrical Characteristics (continued)

Specifications are for  $T_J = 25^\circ\text{C}$  unless otherwise specified. Minimum and Maximum limits are specified through test, design, or statistical correlation. Typical values represent the most likely parametric norm at  $T_J = 25^\circ\text{C}$ , and are provided for reference purposes only. Unless otherwise stated the following conditions apply:  $V_{IN} = 12\text{ V}$ .<sup>(1)(2)(3)</sup>

PARAMETER		TEST CONDITIONS		MIN	TYP	MAX	UNIT
$V_{UVP}$	Undervoltage lockout thresholds	On threshold			3.7		V
			$T_J = -40^\circ\text{C}$ to $125^\circ\text{C}$	4.4			
		Off threshold			3.5		
			$T_J = -40^\circ\text{C}$ to $125^\circ\text{C}$			3.25	
$V_{\overline{\text{SHDN}}}$	Shutdown threshold	Device ON			1		V
			$T_J = -40^\circ\text{C}$ to $125^\circ\text{C}$	2.3			
		Device OFF			0.9		
			$T_J = -40^\circ\text{C}$ to $125^\circ\text{C}$			0.3	
$I_{\overline{\text{SHDN}}}$	Shutdown pin input bias current	$V_{\overline{\text{SHDN}}} = 2.3\text{ V}^{(6)}$			0.05		$\mu\text{A}$
			$T_J = -40^\circ\text{C}$ to $125^\circ\text{C}$			1.5	
		$V_{\overline{\text{SHDN}}} = 0\text{ V}$			0.02		
			$T_J = -40^\circ\text{C}$ to $125^\circ\text{C}$			1.5	

## 6.6 Typical Characteristics

The part numbers in this section represent both the Q1 and non-Q1 versions of the respective parts.

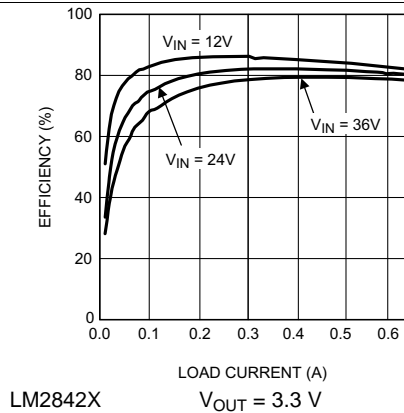

Figure 1. Efficiency vs Load Current

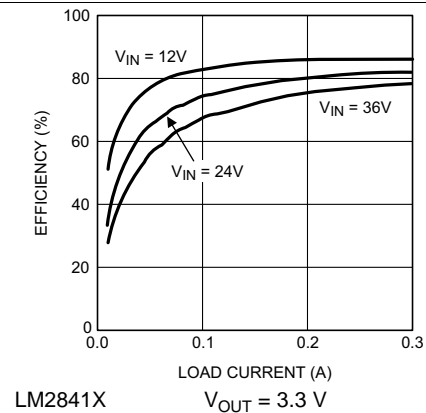

Figure 2. Efficiency vs Load Current

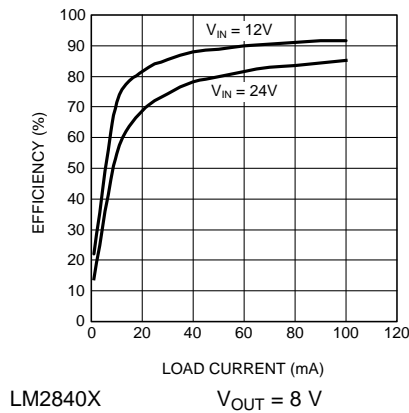

Figure 3. Efficiency vs Load Current

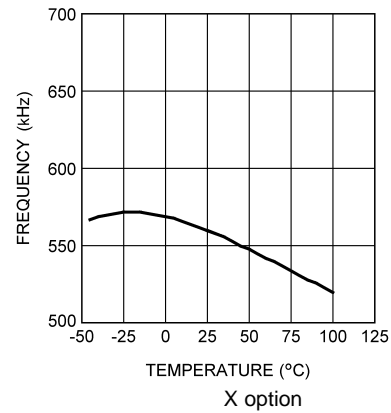

Figure 4. Switching Frequency vs Temperature

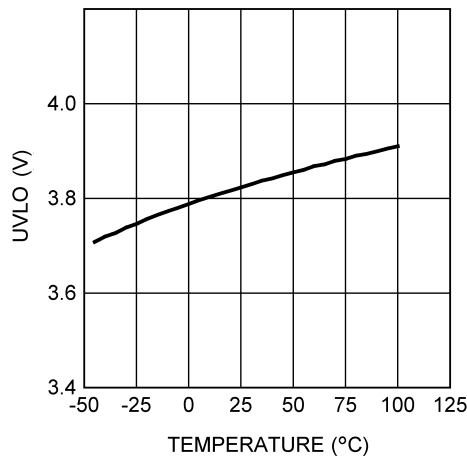

Figure 5. Input UVLO Voltage vs Temperature

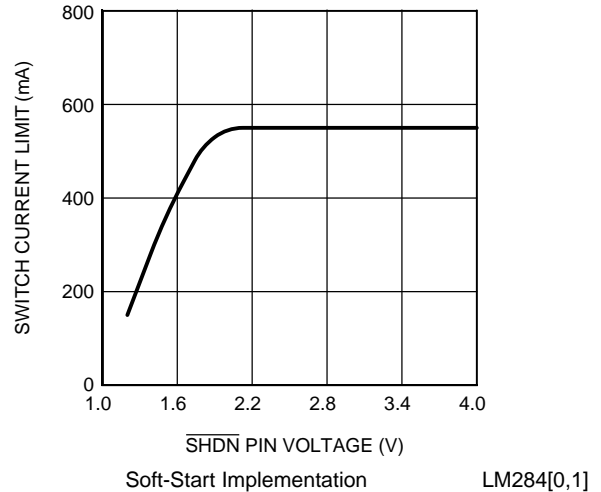
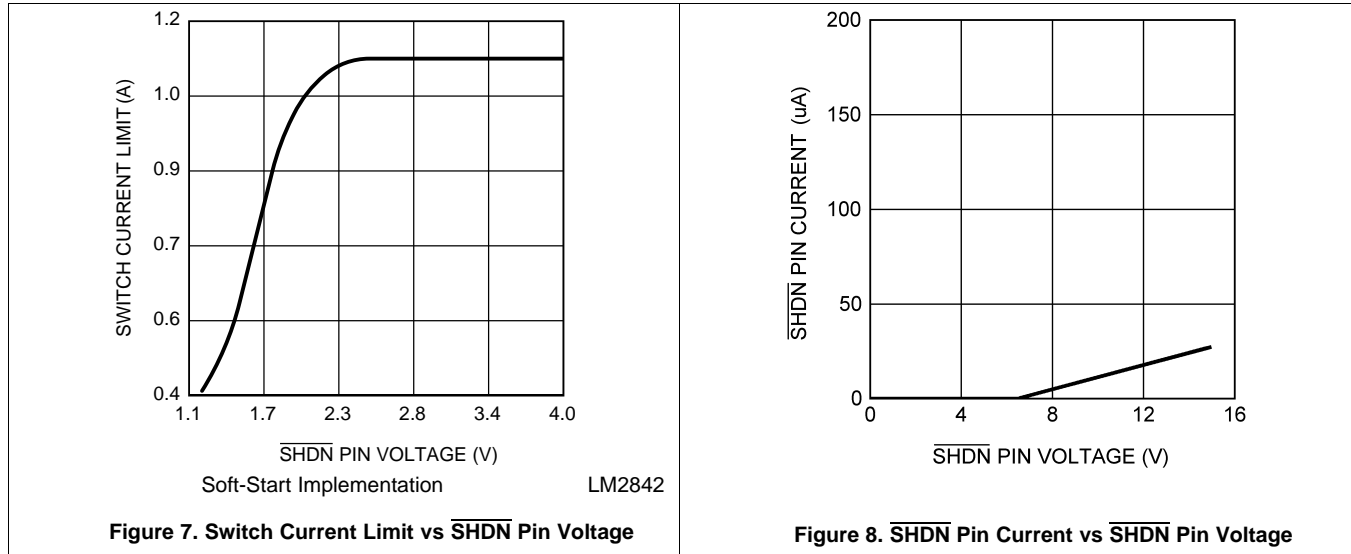

Figure 6. Switch Current Limit vs  $\overline{\text{SHDN}}$  Pin Voltage

### Typical Characteristics (continued)

The part numbers in this section represent both the Q1 and non-Q1 versions of the respective parts.





## 7.4 Device Functional Modes

### 7.4.1 Continuous Conduction Mode

The LM284x contain a current-mode, PWM buck regulator. A buck regulator steps the input voltage down to a lower output voltage. In continuous conduction mode (when the inductor current never reaches zero at steady-state operation), the buck regulator operates in two cycles. The power switch is connected between  $V_{IN}$  and SW. In the first cycle of operation the transistor is closed and the diode is reverse biased. Energy is collected in the inductor and the load current is supplied by  $C_{OUT}$  and the rising current through the inductor. During the second cycle the transistor is open and the diode is forward biased due to the fact that the inductor current cannot instantaneously change direction. The energy stored in the inductor is transferred to the load and output capacitor. The ratio of these two cycles determines the output voltage. The output voltage is defined approximately as shown in [Equation 1](#).

$$D = V_{OUT} / V_{IN} \quad (1)$$

$$D' = (1 - D)$$

where

- D is the duty cycle of the switch (2)

D and D' are required for design calculations.

## 8 Application and Implementation

### NOTE

Information in the following applications sections is not part of the TI component specification, and TI does not warrant its accuracy or completeness. TI's customers are responsible for determining suitability of components for their purposes. Customers should validate and test their design implementation to confirm system functionality.

### 8.1 Application Information

The LM284x are step-down DC/DC regulators. They are typically used to convert a higher DC voltage to a lower DC voltage with a maximum output current of 100 mA, 300 mA, or 600 mA. The following design procedure can be used to select components for the LM284x. Alternately, the WEBENCH® software may be used to generate complete designs. When generating a design, the WEBENCH software uses iterative design procedure and accesses comprehensive databases of components. See [ti.com](http://ti.com) and [Detailed Design Procedure](#) for more details.

### 8.2 Typical Applications

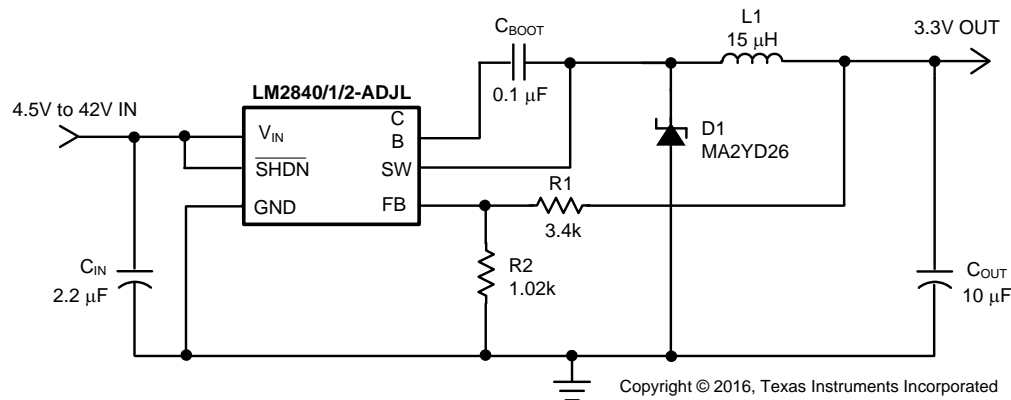

Figure 9. Application Circuit With 3.3-V Output Voltage at 100 mA

#### 8.2.1 Design Requirements

Table 1 lists the design parameters for this example.

Table 1. Design Parameters

DESIGN PARAMETER	EXAMPLE VALUE
Input voltage	4.5 V to 42 V
Output voltage	3.3 V
Output current	0.1 A

#### 8.2.2 Detailed Design Procedure

##### 8.2.2.1 Custom Design With WEBENCH® Tools

[Click here](#) to create a custom design using the LM2840 device with the WEBENCH® Power Designer.

1. Start by entering the input voltage ( $V_{IN}$ ), output voltage ( $V_{OUT}$ ), and output current ( $I_{OUT}$ ) requirements.
2. Optimize the design for key parameters such as efficiency, footprint, and cost using the optimizer dial.
3. Compare the generated design with other possible solutions from Texas Instruments.

The WEBENCH Power Designer provides a customized schematic along with a list of materials with real-time pricing and component availability.

In most cases, these actions are available:

- Run electrical simulations to see important waveforms and circuit performance

- Run thermal simulations to understand board thermal performance
- Export customized schematic and layout into popular CAD formats
- Print PDF reports for the design, and share the design with colleagues

Get more information about WEBENCH tools at [www.ti.com/WEBENCH](http://www.ti.com/WEBENCH).

This section presents guidelines for selecting external components.

### 8.2.2.2 Setting the Output Voltage

The output voltage is set using the feedback pin and a resistor divider connected to the output as shown in [Typical Application Circuit](#). The feedback pin voltage 0.765 V, so the ratio of the feedback resistors sets the output voltage according to [Equation 3](#):

$$V_{OUT} = 0.765 \text{ V} (1 + (R1 / R2)) \tag{3}$$

Typically R2 is given as 100 Ω to 10 kΩ for a starting value. To solve for R1 given R2 and V<sub>OUT</sub>, use [Equation 4](#):

$$R1 = R2 ((V_{OUT} / 0.765 \text{ V}) - 1) \tag{4}$$

### 8.2.2.3 Inductor Selection

The most critical parameters for the inductor are the inductance, peak current, and the DC resistance. The inductance is related to the peak-to-peak inductor ripple current, the input and the output voltages.

$$L = \frac{(V_{IN} - V_{OUT})V_{OUT}}{V_{IN} \times I_{RIPPLE} \times f_{SW}} \tag{5}$$

A higher value of ripple current reduces inductance, but increases the conductance loss, core loss, and current stress for the inductor and switch devices. It also requires a bigger output capacitor for the same output voltage ripple requirement. A reasonable value is setting the ripple current to be 30% of the DC output current. Because the ripple current increases with the input voltage, the maximum input voltage is always used to determine the inductance. The DC resistance of the inductor is a key parameter for the efficiency. Lower DC resistance is available with a bigger winding area. A good tradeoff between the efficiency and the core size is letting the inductor copper loss equal 2% of the output power. See [Selecting Inductors for Buck Converters](#) for more information on selecting inductors. A good starting point for most applications is a 10 μH to 22 μH with 1.1 A or greater current rating for the LM2842 or a 0.7 A or greater current rating for the LM284x . Using such a rating enables the device to current limit without saturating the inductor. This is preferable to the device going into thermal shutdown mode and the possibility of damaging the inductor if the output is shorted to ground or other long-term overload.

**Table 2. Recommended Inductors**

MANUFACTURER	INDUCTOR	CONTACT INFORMATION
Coilcraft	LPS4018, DO1608C, DO3308, and LPO2506 series	<a href="http://www.coilcraft.com">www.coilcraft.com</a> 800-3222645
MuRata	LQH55D and LQH66S series	<a href="http://www.murata.com">www.murata.com</a>
Coiltronics	MP2 and MP2A series	<a href="http://www.cooperbussman.com">www.cooperbussman.com</a>

### 8.2.2.4 Input Capacitor

A low ESR ceramic capacitor (C<sub>IN</sub>) is needed between the V<sub>IN</sub> pin and GND pin. This capacitor prevents large voltage transients from appearing at the input. Use a 2.2-μF to 10-μF value with X5R or X7R dielectric. Depending on construction, a ceramic capacitor's value can decrease up to 50% of its nominal value when rated voltage is applied. Consult with the capacitor manufacturer's data sheet for information on capacitor derating over voltage and temperature.

### 8.2.2.5 Output Capacitor

The selection of  $C_{OUT}$  is driven by the maximum allowable output voltage ripple. The output ripple in the constant frequency, PWM mode is approximated by Equation 6.

$$V_{RIPPLE} = I_{RIPPLE} (ESR + (1 / (8f_{SW}C_{OUT}))) \quad (6)$$

The ESR term usually plays the dominant role in determining the voltage ripple. Low-ESR ceramic capacitors are recommended. Capacitors in the range of 22  $\mu$ F to 100  $\mu$ F are a good starting point with an ESR of 0.1  $\Omega$  or less.

**Table 3. Recommended Input and Output Capacitors**

MANUFACTURER	CAPACITOR	CONTACT INFORMATION
Vishay Sprague	293D, 592D, and 595D series tantalum	<a href="http://www.vishay.com">www.vishay.com</a> 407-324-4140
Taiyo Yuden	High capacitance MLCC ceramic	<a href="http://www.t-yuden.com">www.t-yuden.com</a> 408-573-4150
Cornell Dubilier	ESRD series Polymer Aluminum Electrolytic SPV and AFK series V-chip series	<a href="http://www.cde.com">www.cde.com</a>
MuRata	High capacitance MLCC ceramic	<a href="http://www.murata.com">www.murata.com</a>

### 8.2.2.6 Bootstrap Capacitor

A 0.15- $\mu$ F ceramic capacitor or larger is recommended for the bootstrap capacitor ( $C_{BOOT}$ ). For applications where the input voltage is less than twice the output voltage a larger capacitor is recommended, generally 0.15  $\mu$ F to 1  $\mu$ F to ensure plenty of gate drive for the internal switches and a consistently low  $R_{DS(ON)}$ .

### 8.2.2.7 Soft-Start Components

The devices have circuitry that is used in conjunction with the  $\overline{SHDN}$  pin to limit the inrush current on start-up of the DC/DC switching regulator. The  $\overline{SHDN}$  pin in conjunction with a RC filter is used to tailor the soft start for a specific application. When a voltage applied to the  $\overline{SHDN}$  pin is between 0 V and up to 2.3 V it causes the cycle-by-cycle current limit in the power stage to be modulated for minimum current limit at 0 V up to the rated current limit at 2.3 V. Thus controlling the output rise time and inrush current at start-up. The resistor value must be selected so the current injected into the  $\overline{SHDN}$  pin is greater than the leakage current of the  $\overline{SHDN}$  pin (1.5  $\mu$ A) when the voltage at  $\overline{SHDN}$  is equal or greater than 2.3 V.

### 8.2.2.8 Shutdown Operation

The  $\overline{SHDN}$  pin of the LM284x is designed so that it may be controlled using 2.3 V or higher logic signals. If the shutdown function is not to be used the  $\overline{SHDN}$  pin may be tied to  $V_{IN}$ . This input must not be allowed to float

The maximum voltage to the  $\overline{SHDN}$  pin should not exceed 42 V. If the use of a higher voltage is desired due to system or other constraints it may be used; however, a 100 k $\Omega$  or larger resistor is recommended between the applied voltage and the  $\overline{SHDN}$  pin to protect the device.

### 8.2.2.9 Schottky Diode

The breakdown voltage rating of the diode (D1) is preferred to be 25% higher than the maximum input voltage. The current rating for the diode must be equal to the maximum output current for best reliability in most applications. In cases where the duty cycle is greater than 50%, the average diode current is lower. In this case it is possible to use a diode with a lower average current rating, approximately  $(1 - D)I_{OUT}$ ; however, the peak current rating should be higher than the maximum load current. A 0.5-A to 1-A rated diode is a good starting point.

### 8.2.3 Application Curves

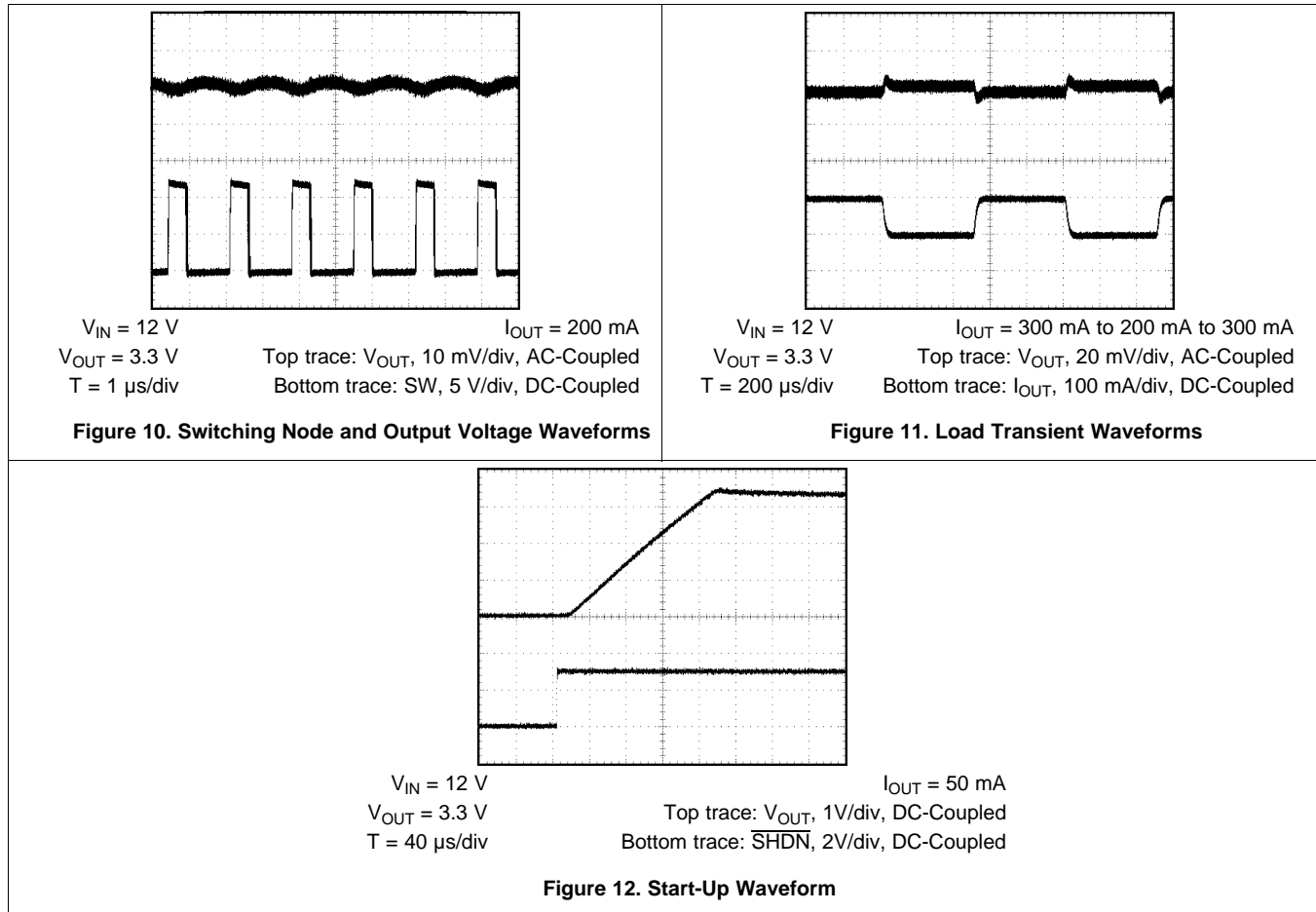

### 8.2.4 Other Application Circuits

Figure 13 to Figure 16 show application circuit examples using the LM284x devices. Customers must fully validate and test these circuits before implementing a design based on these examples. Unless otherwise noted, the design procedures in are applicable to these designs.

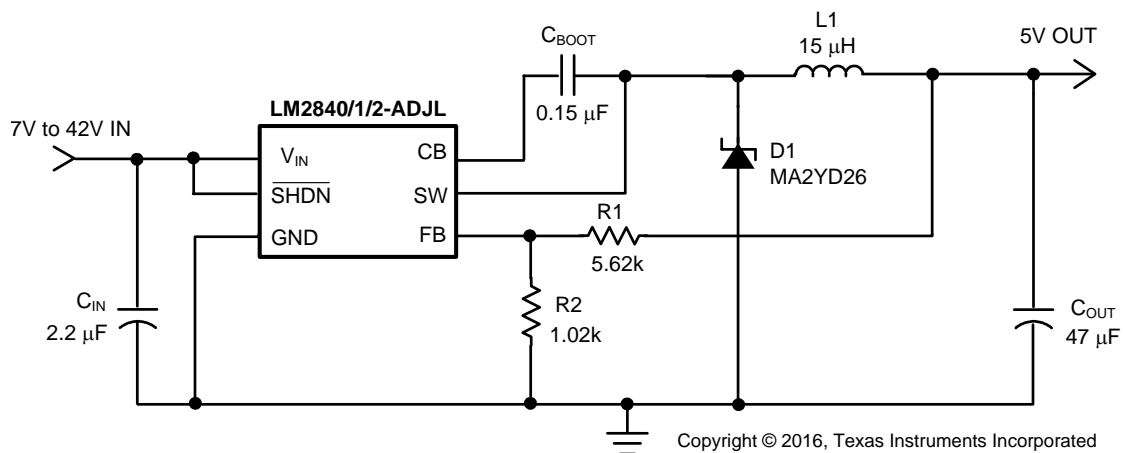

Figure 13. Step-Down Converter With 5-V Output Voltage

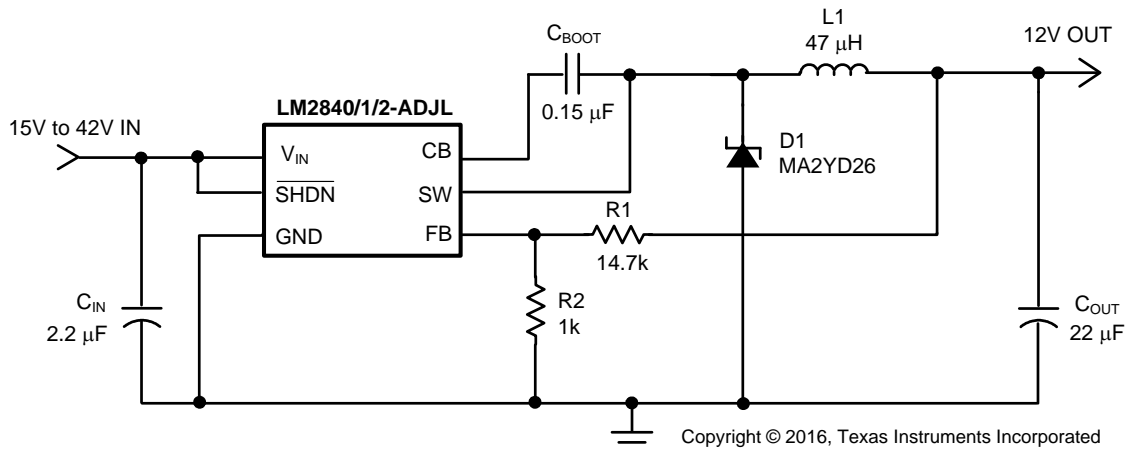

Figure 14. Step-Down Converter With 12-V Output Voltage

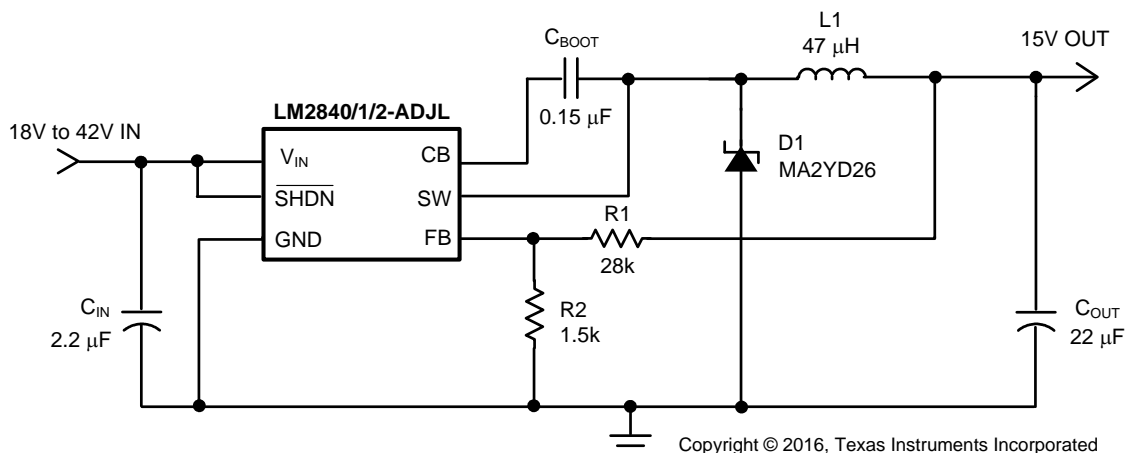

Figure 15. Step-Down Converter With 15-V Output Voltage

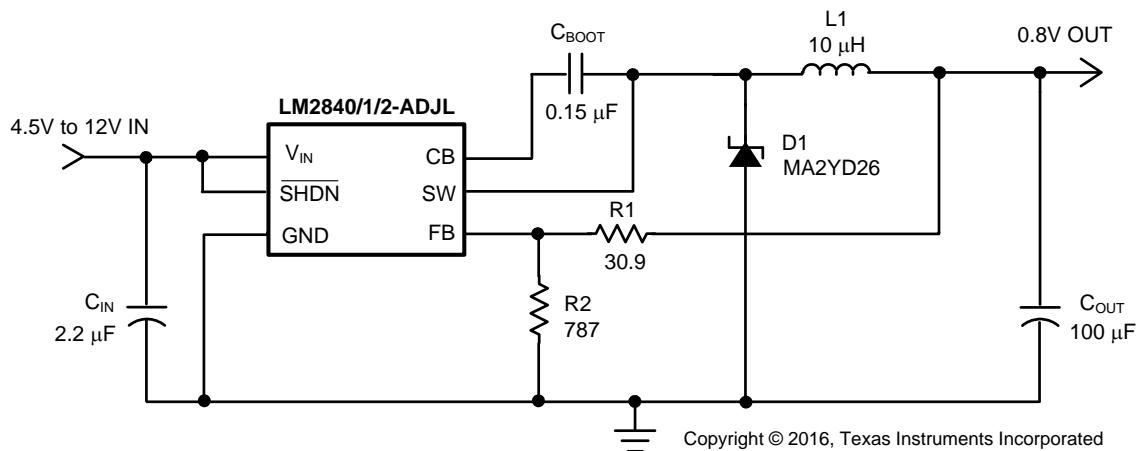

Figure 16. Step-Down Converter With 0.8-V Output Voltage

## 9 Power Supply Recommendations

The LM284x are designed to operate from an input voltage supply range between 4 V and 42 V. This input supply must be able to withstand the maximum input current and maintain a voltage above 4.5 V. The resistance of the input supply rail must be low enough that an input current transient does not cause a drop at the device supply voltage high enough to cause a false UVLO fault triggering and system reset. If the input supply is located more than a few inches from the device, additional bulk capacitance may be required in addition to the ceramic input capacitors.

## 10 Layout

### 10.1 Layout Guidelines

To reduce problems with conducted noise pickup, the ground side of the feedback network should be connected directly to the GND pin with its own connection. The feedback network, resistors R1 and R2, must be kept close to the FB pin, and away from the inductor to minimize coupling noise into the feedback pin. The input bypass capacitor  $C_{IN}$  must be placed close to the  $V_{IN}$  pin. This reduces copper trace resistance, which effects input voltage ripple of the IC. The inductor L1 must be placed close to the SW pin to reduce EMI and capacitive coupling. The output capacitor,  $C_{OUT}$  must be placed close to the junction of L1 and the diode D1. The L1, D1, and  $C_{OUT}$  trace must be as short as possible to reduce conducted and radiated noise and increase overall efficiency. The ground connection for the diode,  $C_{IN}$ , and  $C_{OUT}$  must be as small as possible and tied to the system ground plane in only one spot (preferably at the  $C_{OUT}$  ground point) to minimize conducted noise in the system ground plane. See [Layout Guidelines for Switching Power Supplies](#) for more detail on switching power supply layout considerations.

### 10.2 Layout Example

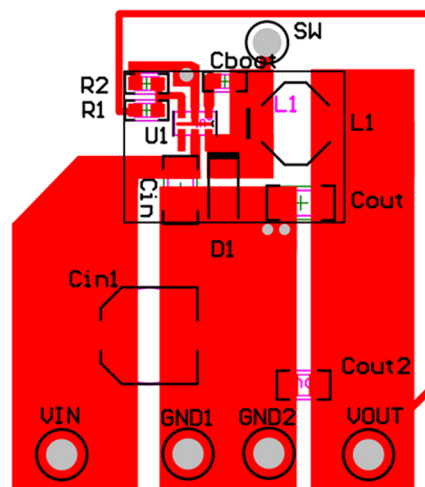

Figure 17. Recommended Layout

## 11 Device and Documentation Support

### 11.1 Device Support

#### 11.1.1 Third-Party Products Disclaimer

TI'S PUBLICATION OF INFORMATION REGARDING THIRD-PARTY PRODUCTS OR SERVICES DOES NOT CONSTITUTE AN ENDORSEMENT REGARDING THE SUITABILITY OF SUCH PRODUCTS OR SERVICES OR A WARRANTY, REPRESENTATION OR ENDORSEMENT OF SUCH PRODUCTS OR SERVICES, EITHER ALONE OR IN COMBINATION WITH ANY TI PRODUCT OR SERVICE.

#### 11.1.2 Development Support

##### 11.1.2.1 Custom Design With WEBENCH® Tools

[Click here](#) to create a custom design using the LM2840 device with the WEBENCH® Power Designer.

1. Start by entering the input voltage ( $V_{IN}$ ), output voltage ( $V_{OUT}$ ), and output current ( $I_{OUT}$ ) requirements.
2. Optimize the design for key parameters such as efficiency, footprint, and cost using the optimizer dial.
3. Compare the generated design with other possible solutions from Texas Instruments.

The WEBENCH Power Designer provides a customized schematic along with a list of materials with real-time pricing and component availability.

In most cases, these actions are available:

- Run electrical simulations to see important waveforms and circuit performance
- Run thermal simulations to understand board thermal performance
- Export customized schematic and layout into popular CAD formats
- Print PDF reports for the design, and share the design with colleagues

Get more information about WEBENCH tools at [www.ti.com/WEBENCH](http://www.ti.com/WEBENCH).

### 11.2 Documentation Support

#### 11.2.1 Related Documentation

For related documentation, see the following:

- [AN-1197 Selecting Inductors for Buck Converters](#) (SNVA038)
- [AN-1149 Layout Guidelines for Switching Power Supplies](#) (SNVA021)

### 11.3 Related Links

The table below lists quick access links. Categories include technical documents, support and community resources, tools and software, and quick access to order now.

**Table 4. Related Links**

PARTS	PRODUCT FOLDER	ORDER NOW	TECHNICAL DOCUMENTS	TOOLS & SOFTWARE	SUPPORT & COMMUNITY
LM2840	<a href="#">Click here</a>	<a href="#">Click here</a>	<a href="#">Click here</a>	<a href="#">Click here</a>	<a href="#">Click here</a>
LM2841	<a href="#">Click here</a>	<a href="#">Click here</a>	<a href="#">Click here</a>	<a href="#">Click here</a>	<a href="#">Click here</a>
LM2842	<a href="#">Click here</a>	<a href="#">Click here</a>	<a href="#">Click here</a>	<a href="#">Click here</a>	<a href="#">Click here</a>

### 11.4 Receiving Notification of Documentation Updates

To receive notification of documentation updates, navigate to the device product folder on ti.com. In the upper right corner, click on *Alert me* to register and receive a weekly digest of any product information that has changed. For change details, review the revision history included in any revised document.

## 11.5 Community Resources

The following links connect to TI community resources. Linked contents are provided "AS IS" by the respective contributors. They do not constitute TI specifications and do not necessarily reflect TI's views; see TI's [Terms of Use](#).

**TI E2E™ Online Community** *TI's Engineer-to-Engineer (E2E) Community*. Created to foster collaboration among engineers. At [e2e.ti.com](http://e2e.ti.com), you can ask questions, share knowledge, explore ideas and help solve problems with fellow engineers.

**Design Support** *TI's Design Support* Quickly find helpful E2E forums along with design support tools and contact information for technical support.

## 11.6 Trademarks

SIMPLE SWITCHER, E2E are trademarks of Texas Instruments.  
WEBENCH, SIMPLE SWITCHER are registered trademarks of Texas Instruments.  
All other trademarks are the property of their respective owners.

## 11.7 Electrostatic Discharge Caution



These devices have limited built-in ESD protection. The leads should be shorted together or the device placed in conductive foam during storage or handling to prevent electrostatic damage to the MOS gates.

## 11.8 Glossary

[SLYZ022](#) — *TI Glossary*.

This glossary lists and explains terms, acronyms, and definitions.

## 12 Mechanical, Packaging, and Orderable Information

The following pages include mechanical, packaging, and orderable information. This information is the most current data available for the designated devices. This data is subject to change without notice and revision of this document. For browser-based versions of this data sheet, refer to the left-hand navigation.

**PACKAGING INFORMATION**

Orderable Device	Status (1)	Package Type	Package Drawing	Pins	Package Qty	Eco Plan (2)	Lead/Ball Finish (6)	MSL Peak Temp (3)	Op Temp (°C)	Device Marking (4/5)	Samples
LM2840XMK-ADJL/NOPB	ACTIVE	SOT-23-THIN	DDC	6	1000	Green (RoHS & no Sb/Br)	CU SN	Level-1-260C-UNLIM	-40 to 125	SE8B	<a href="#">Samples</a>
LM2840XMKX-ADJL/NOPB	ACTIVE	SOT-23-THIN	DDC	6	3000	Green (RoHS & no Sb/Br)	CU SN	Level-1-260C-UNLIM	-40 to 125	SE8B	<a href="#">Samples</a>
LM2840YMK-ADJL/NOPB	ACTIVE	SOT-23-THIN	DDC	6	1000	Green (RoHS & no Sb/Br)	CU SN	Level-1-260C-UNLIM	-40 to 125	SF1B	<a href="#">Samples</a>
LM2841XMK-ADJL/NOPB	ACTIVE	SOT-23-THIN	DDC	6	1000	Green (RoHS & no Sb/Br)	CU SN	Level-1-260C-UNLIM	-40 to 125	STFB	<a href="#">Samples</a>
LM2841XMKX-ADJL/NOPB	ACTIVE	SOT-23-THIN	DDC	6	3000	Green (RoHS & no Sb/Br)	CU SN	Level-1-260C-UNLIM	-40 to 125	STFB	<a href="#">Samples</a>
LM2841YMK-ADJL/NOPB	ACTIVE	SOT-23-THIN	DDC	6	1000	Green (RoHS & no Sb/Br)	CU SN	Level-1-260C-UNLIM	-40 to 125	STTB	<a href="#">Samples</a>
LM2841YMKX-ADJL/NOPB	ACTIVE	SOT-23-THIN	DDC	6	3000	Green (RoHS & no Sb/Br)	CU SN	Level-1-260C-UNLIM	-40 to 125	STTB	<a href="#">Samples</a>
LM2842XMK-ADJL/NOPB	ACTIVE	SOT-23-THIN	DDC	6	1000	Green (RoHS & no Sb/Br)	CU SN	Level-1-260C-UNLIM	-40 to 125	STVB	<a href="#">Samples</a>
LM2842XMKX-ADJL/NOPB	ACTIVE	SOT-23-THIN	DDC	6	3000	Green (RoHS & no Sb/Br)	CU SN	Level-1-260C-UNLIM	-40 to 125	STVB	<a href="#">Samples</a>
LM2842YMK-ADJL/NOPB	ACTIVE	SOT-23-THIN	DDC	6	1000	Green (RoHS & no Sb/Br)	CU SN	Level-1-260C-UNLIM	-40 to 125	STXB	<a href="#">Samples</a>
LM2842YMKX-ADJL/NOPB	ACTIVE	SOT-23-THIN	DDC	6	3000	Green (RoHS & no Sb/Br)	CU SN	Level-1-260C-UNLIM	-40 to 125	STXB	<a href="#">Samples</a>

(1) The marketing status values are defined as follows:

**ACTIVE:** Product device recommended for new designs.

**LIFEBUY:** TI has announced that the device will be discontinued, and a lifetime-buy period is in effect.

**NRND:** Not recommended for new designs. Device is in production to support existing customers, but TI does not recommend using this part in a new design.

**PREVIEW:** Device has been announced but is not in production. Samples may or may not be available.

**OBSOLETE:** TI has discontinued the production of the device.

(2) **RoHS:** TI defines "RoHS" to mean semiconductor products that are compliant with the current EU RoHS requirements for all 10 RoHS substances, including the requirement that RoHS substance do not exceed 0.1% by weight in homogeneous materials. Where designed to be soldered at high temperatures, "RoHS" products are suitable for use in specified lead-free processes. TI may reference these types of products as "Pb-Free".

**RoHS Exempt:** TI defines "RoHS Exempt" to mean products that contain lead but are compliant with EU RoHS pursuant to a specific EU RoHS exemption.

**Green:** TI defines "Green" to mean the content of Chlorine (Cl) and Bromine (Br) based flame retardants meet JS709B low halogen requirements of <=1000ppm threshold. Antimony trioxide based flame retardants must also meet the <=1000ppm threshold requirement.

- (3) MSL, Peak Temp. - The Moisture Sensitivity Level rating according to the JEDEC industry standard classifications, and peak solder temperature.
- (4) There may be additional marking, which relates to the logo, the lot trace code information, or the environmental category on the device.
- (5) Multiple Device Markings will be inside parentheses. Only one Device Marking contained in parentheses and separated by a "~" will appear on a device. If a line is indented then it is a continuation of the previous line and the two combined represent the entire Device Marking for that device.
- (6) Lead/Ball Finish - Orderable Devices may have multiple material finish options. Finish options are separated by a vertical ruled line. Lead/Ball Finish values may wrap to two lines if the finish value exceeds the maximum column width.

**Important Information and Disclaimer:**The information provided on this page represents TI's knowledge and belief as of the date that it is provided. TI bases its knowledge and belief on information provided by third parties, and makes no representation or warranty as to the accuracy of such information. Efforts are underway to better integrate information from third parties. TI has taken and continues to take reasonable steps to provide representative and accurate information but may not have conducted destructive testing or chemical analysis on incoming materials and chemicals. TI and TI suppliers consider certain information to be proprietary, and thus CAS numbers and other limited information may not be available for release.

In no event shall TI's liability arising out of such information exceed the total purchase price of the TI part(s) at issue in this document sold by TI to Customer on an annual basis.

**OTHER QUALIFIED VERSIONS OF LM2840, LM2841, LM2842 :**

- Automotive: [LM2840-Q1](#), [LM2841-Q1](#), [LM2842-Q1](#)

**NOTE: Qualified Version Definitions:**

- Automotive - Q100 devices qualified for high-reliability automotive applications targeting zero defects

**TAPE AND REEL INFORMATION**

**QUADRANT ASSIGNMENTS FOR PIN 1 ORIENTATION IN TAPE**

\*All dimensions are nominal

Device	Package Type	Package Drawing	Pins	SPQ	Reel Diameter (mm)	Reel Width W1 (mm)	A0 (mm)	B0 (mm)	K0 (mm)	P1 (mm)	W (mm)	Pin1 Quadrant
LM2840XMK-ADJL/NOPB	SOT-23-THIN	DDC	6	1000	178.0	8.4	3.2	3.2	1.4	4.0	8.0	Q3
LM2840XMKX-ADJL/NOPB	SOT-23-THIN	DDC	6	3000	178.0	8.4	3.2	3.2	1.4	4.0	8.0	Q3
LM2840YMK-ADJL/NOPB	SOT-23-THIN	DDC	6	1000	178.0	8.4	3.2	3.2	1.4	4.0	8.0	Q3
LM2841XMK-ADJL/NOPB	SOT-23-THIN	DDC	6	1000	178.0	8.4	3.2	3.2	1.4	4.0	8.0	Q3
LM2841XMKX-ADJL/NOPB	SOT-23-THIN	DDC	6	3000	178.0	8.4	3.2	3.2	1.4	4.0	8.0	Q3
LM2841YMK-ADJL/NOPB	SOT-23-THIN	DDC	6	1000	178.0	8.4	3.2	3.2	1.4	4.0	8.0	Q3
LM2841YMKX-ADJL/NOPB	SOT-23-THIN	DDC	6	3000	178.0	8.4	3.2	3.2	1.4	4.0	8.0	Q3
LM2842XMK-ADJL/NOPB	SOT-23-THIN	DDC	6	1000	178.0	8.4	3.2	3.2	1.4	4.0	8.0	Q3
LM2842XMKX-ADJL/NOPB	SOT-23-THIN	DDC	6	3000	178.0	8.4	3.2	3.2	1.4	4.0	8.0	Q3
LM2842YMK-ADJL/NOPB	SOT-23-THIN	DDC	6	1000	178.0	8.4	3.2	3.2	1.4	4.0	8.0	Q3
LM2842YMKX-ADJL/NOPB	SOT-23-THIN	DDC	6	3000	178.0	8.4	3.2	3.2	1.4	4.0	8.0	Q3

Device	Package Type	Package Drawing	Pins	SPQ	Reel Diameter (mm)	Reel Width W1 (mm)	A0 (mm)	B0 (mm)	K0 (mm)	P1 (mm)	W (mm)	Pin1 Quadrant
B	23-THIN											

**TAPE AND REEL BOX DIMENSIONS**

\*All dimensions are nominal

Device	Package Type	Package Drawing	Pins	SPQ	Length (mm)	Width (mm)	Height (mm)
LM2840XMK-ADJL/NOPB	SOT-23-THIN	DDC	6	1000	210.0	185.0	35.0
LM2840XMKX-ADJL/NOPB	SOT-23-THIN	DDC	6	3000	210.0	185.0	35.0
LM2840YMK-ADJL/NOPB	SOT-23-THIN	DDC	6	1000	210.0	185.0	35.0
LM2841XMK-ADJL/NOPB	SOT-23-THIN	DDC	6	1000	210.0	185.0	35.0
LM2841XMKX-ADJL/NOPB	SOT-23-THIN	DDC	6	3000	210.0	185.0	35.0
LM2841YMK-ADJL/NOPB	SOT-23-THIN	DDC	6	1000	210.0	185.0	35.0
LM2841YMKX-ADJL/NOPB	SOT-23-THIN	DDC	6	3000	210.0	185.0	35.0
LM2842XMK-ADJL/NOPB	SOT-23-THIN	DDC	6	1000	210.0	185.0	35.0
LM2842XMKX-ADJL/NOPB	SOT-23-THIN	DDC	6	3000	210.0	185.0	35.0
LM2842YMK-ADJL/NOPB	SOT-23-THIN	DDC	6	1000	210.0	185.0	35.0
LM2842YMKX-ADJL/NOPB	SOT-23-THIN	DDC	6	3000	210.0	185.0	35.0

DDC (R-PDSO-G6)

PLASTIC SMALL-OUTLINE

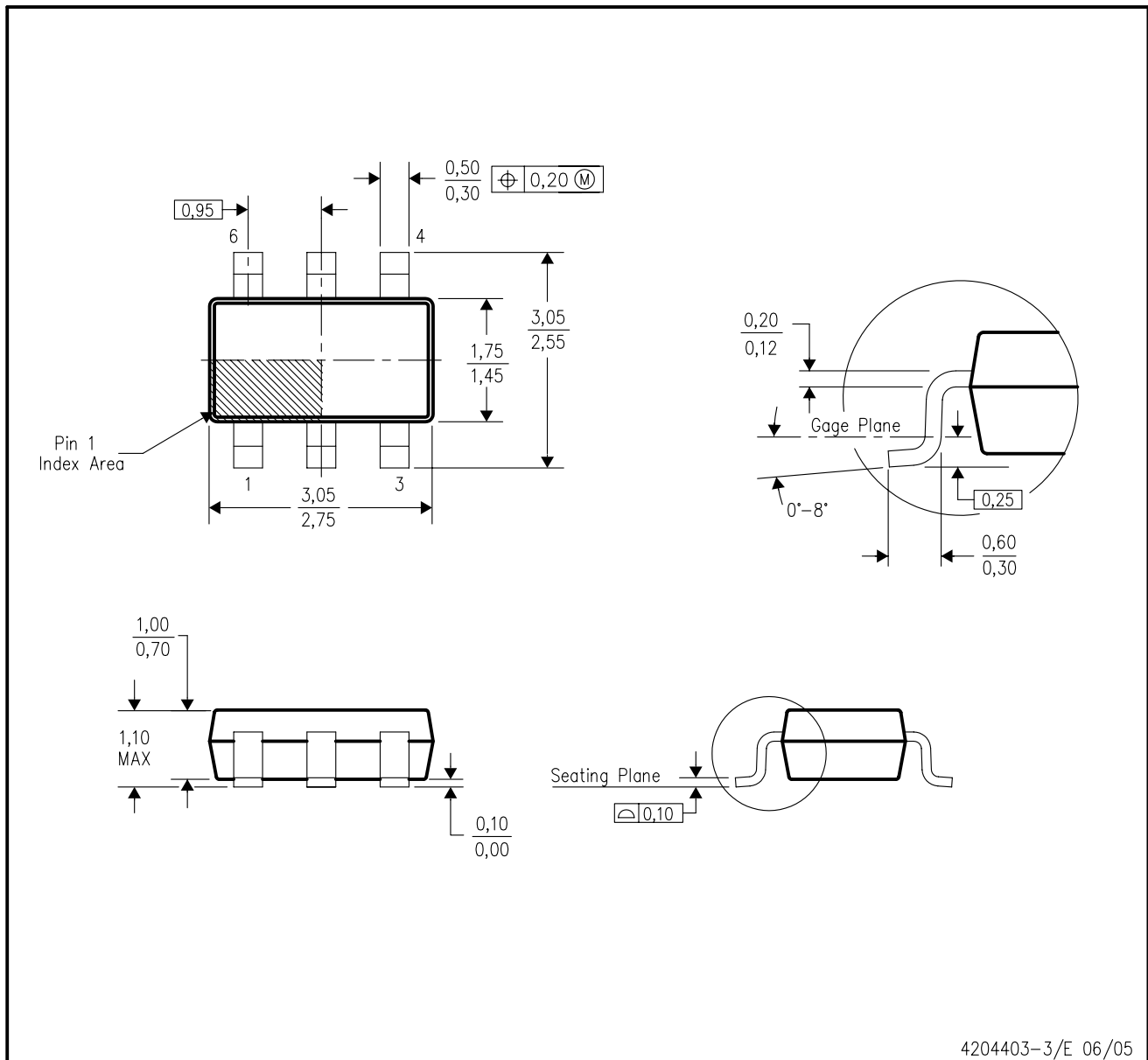

- NOTES:
- All linear dimensions are in millimeters.
  - This drawing is subject to change without notice.
  - Body dimensions do not include mold flash or protrusion.
  - Falls within JEDEC MO-193 variation AA (6 pin).

DDC (R-PDSO-G6)

PLASTIC SMALL OUTLINE

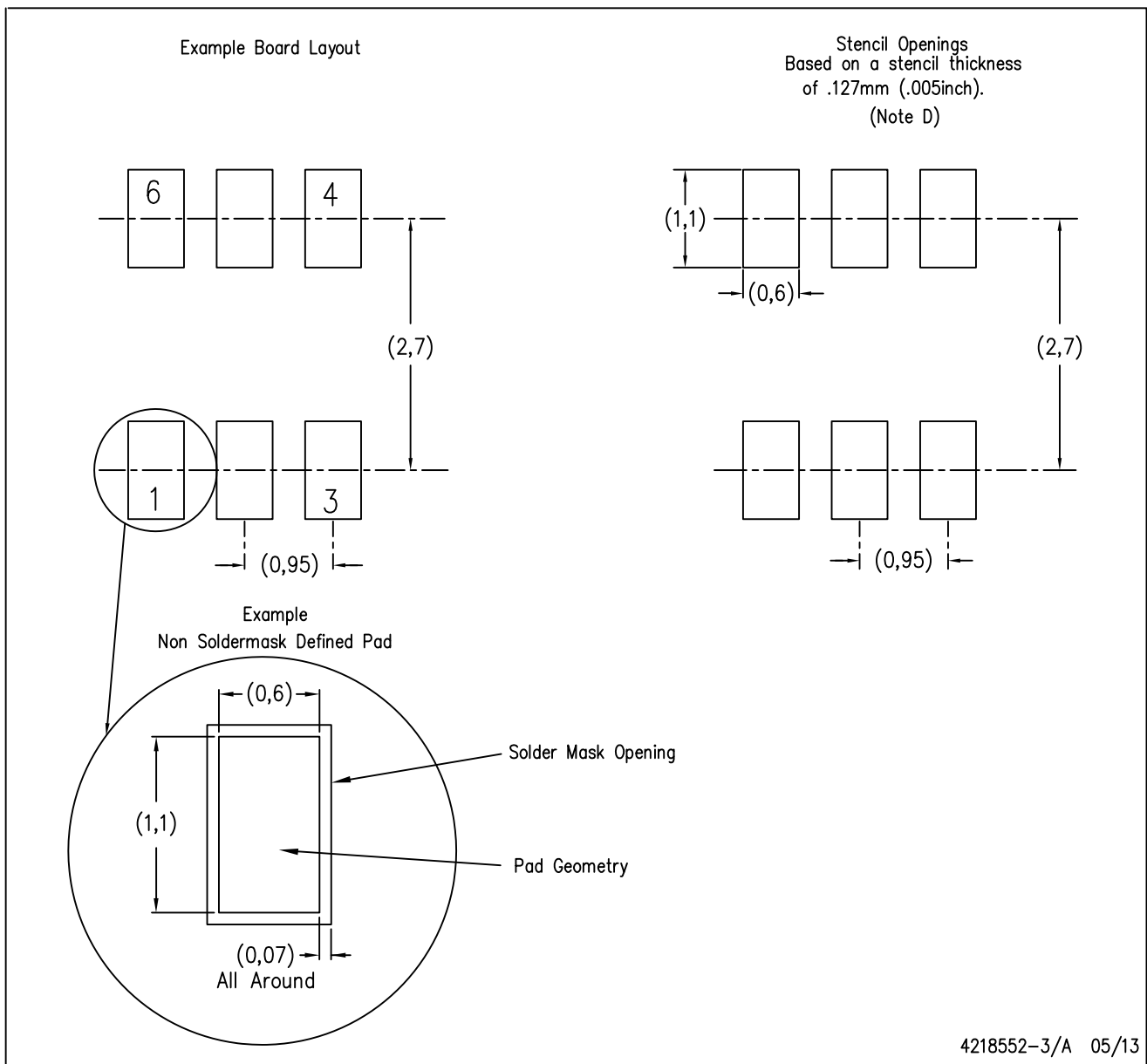

- NOTES:
- A. All linear dimensions are in millimeters.
  - B. This drawing is subject to change without notice.
  - C. Publication IPC-7351 is recommended for alternate designs.
  - D. Laser cutting apertures with trapezoidal walls and also rounding corners will offer better paste release. Customers should contact their board assembly site for stencil design recommendations. Example stencil design based on a 50% volumetric metal load solder paste. Refer to IPC-7525 for other stencil recommendations.

## IMPORTANT NOTICE AND DISCLAIMER

TI PROVIDES TECHNICAL AND RELIABILITY DATA (INCLUDING DATASHEETS), DESIGN RESOURCES (INCLUDING REFERENCE DESIGNS), APPLICATION OR OTHER DESIGN ADVICE, WEB TOOLS, SAFETY INFORMATION, AND OTHER RESOURCES "AS IS" AND WITH ALL FAULTS, AND DISCLAIMS ALL WARRANTIES, EXPRESS AND IMPLIED, INCLUDING WITHOUT LIMITATION ANY IMPLIED WARRANTIES OF MERCHANTABILITY, FITNESS FOR A PARTICULAR PURPOSE OR NON-INFRINGEMENT OF THIRD PARTY INTELLECTUAL PROPERTY RIGHTS.

These resources are intended for skilled developers designing with TI products. You are solely responsible for (1) selecting the appropriate TI products for your application, (2) designing, validating and testing your application, and (3) ensuring your application meets applicable standards, and any other safety, security, or other requirements. These resources are subject to change without notice. TI grants you permission to use these resources only for development of an application that uses the TI products described in the resource. Other reproduction and display of these resources is prohibited. No license is granted to any other TI intellectual property right or to any third party intellectual property right. TI disclaims responsibility for, and you will fully indemnify TI and its representatives against, any claims, damages, costs, losses, and liabilities arising out of your use of these resources.

TI's products are provided subject to TI's Terms of Sale ([www.ti.com/legal/termsofsale.html](http://www.ti.com/legal/termsofsale.html)) or other applicable terms available either on [ti.com](http://ti.com) or provided in conjunction with such TI products. TI's provision of these resources does not expand or otherwise alter TI's applicable warranties or warranty disclaimers for TI products.

Mailing Address: Texas Instruments, Post Office Box 655303, Dallas, Texas 75265  
Copyright © 2019, Texas Instruments Incorporated

## Looking for pricing, stock, or lifecycle information?

Click below to explore more details on WIN SOURCE:

 [View LM2842YMKX-ADJL on WIN SOURCE](#)

 [Texas Instruments](#) Information

## Optimize Your Supply Chain with WIN SOURCE Solutions

-  Global Sourcing Solution
-  Obsolete Management
-  Cost Control Management
-  Shortage Management
-  Alternative Solution
-  Excess Inventory Management