

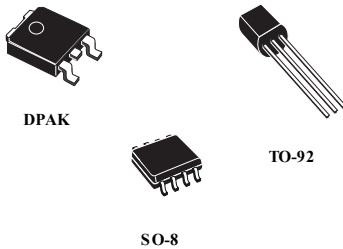

# THE DATASHEET OF LM2931BV50



## Very low drop voltage regulators with inhibit function



### Features

- AEC-Q100 qualified (DPAK only)
- Very low dropout voltage (90 mV typ. at 10 mA load)
- Low quiescent current (typ. 2.5 mA, at 100 mA load)
- Output current up to 100 mA
- Adjustable (from  $V_{OUT} = 2.5$  V only SO-8) and fixed (3.3 V and 5 V) output voltage version
- Internal current and thermal limit
- Load dump protection up to 60 V
- Reverse transient protection up to - 50 V
- Temperature range: - 40 to 125 °C
- Package available: TO-92, DPAK, SO-8 (with inhibit control)

### Description

The LM2931 are very low drop regulators. The very low drop voltage and the low quiescent current make them particularly suitable for low noise, low power applications and in battery-powered systems. In the 8-pin configuration (SO-8), fully compatible with the older L78L family, a shutdown logic control function is available. This means that when the device is used as a local regulator it is possible to put a part of the board in standby, decreasing total power consumption. Ideal for automotive applications, LM2931 is protected from reverse battery installations or 2 battery jumps. During the transient, such as a 60 V load dump, when the input voltage can exceed the specified maximum operating input voltage of 26 V, the regulator automatically shuts down to protect both internal circuitry and the load.

Maturity status link

[LM2931](#)

# 1 Diagram

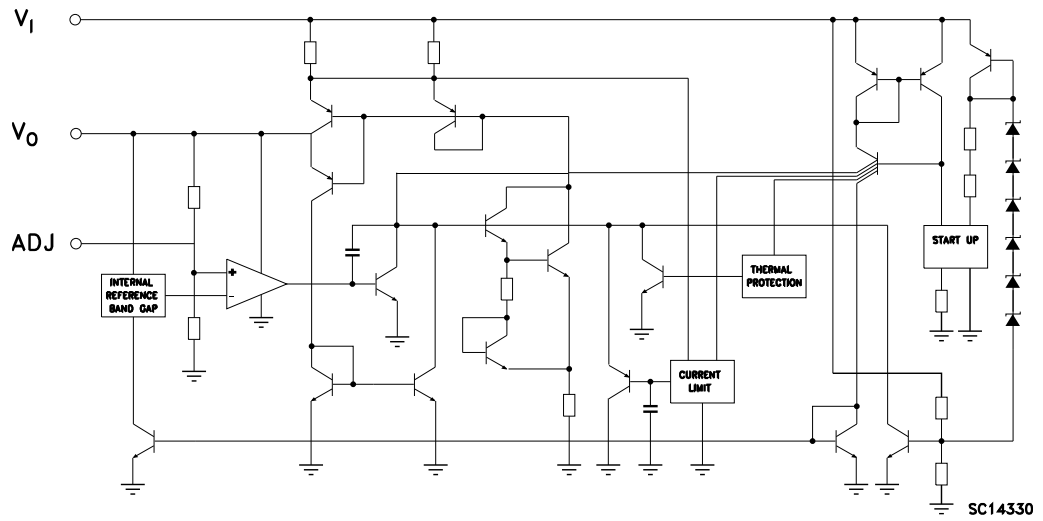
**Figure 2. Schematic diagram**

AMG110720161100MT

## 2 Pin configuration

Figure 3. Pin connections (top view)

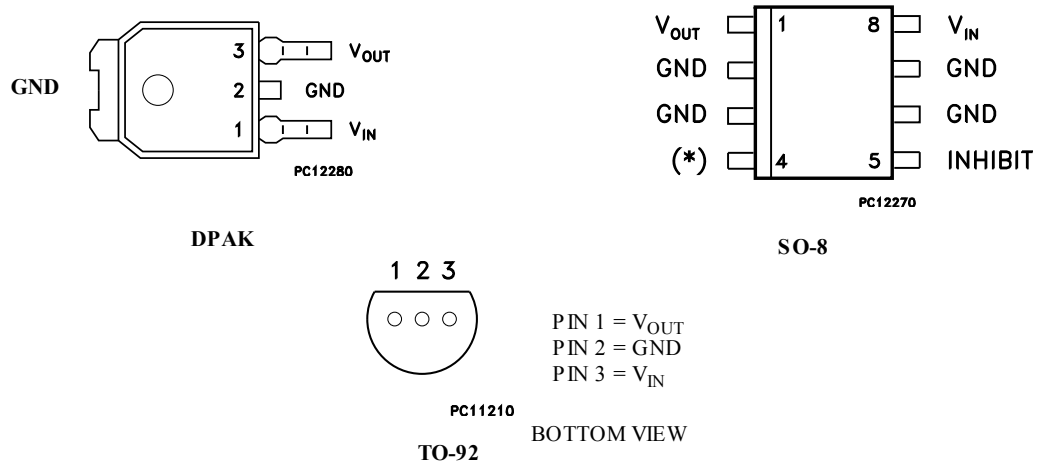

AMG110720161101MT

Note: (\*) ADJ pin on the adjustable version, not connected in the fixed output version.

### 3 Maximum ratings

**Table 1. Absolute maximum ratings**

Symbol	Parameter	Value	Unit
$V_I$	DC positive input voltage	40	V
$V_I$	DC reverse input voltage	-15	V
$V_I$	Transient input voltage (T < 100 ms)	60	V
$V_I$	Transient reverse input voltage (T < 100 ms)	-50	V
$V_{INH}$	Inhibit input voltage	40	V
$I_O$	Output current	Internally limited	
$T_{STG}$	Storage temperature range	-65 to 150	°C
$T_{OP}$	Operating junction temperature range	-40 to 125	°C

**Note:** Absolute maximum ratings are those values beyond which damage to the device may occur. Functional operation under these condition is not implied.

**Table 2. Thermal data**

Symbol	Parameter	SO-8	DPAK	TO-92	Unit
$R_{thJC}$	Thermal resistance junction-case	20	8	57	°C/W
$R_{thJA}$	Thermal resistance junction-ambient	55 <sup>(1)</sup>	100	200	°C/W

1. Considering 6 cm<sup>2</sup> of copper board heat-sink.

## 4 Application circuits

Figure 4. Application circuit for fixed output

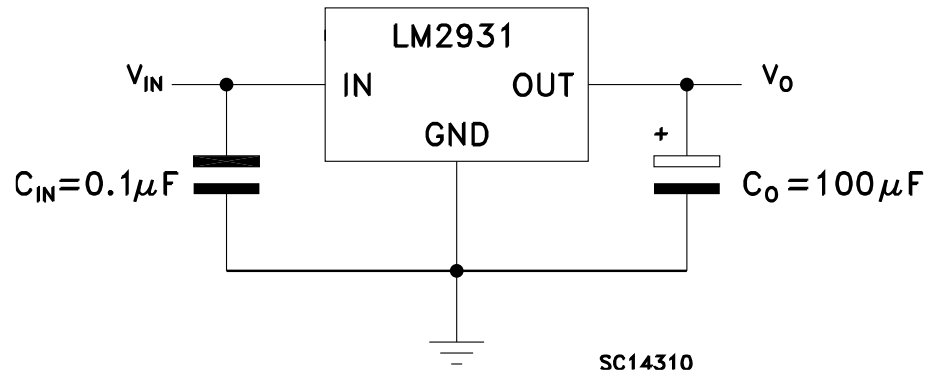

AMG110720161102MT

Figure 5. Application circuit for adjustable output

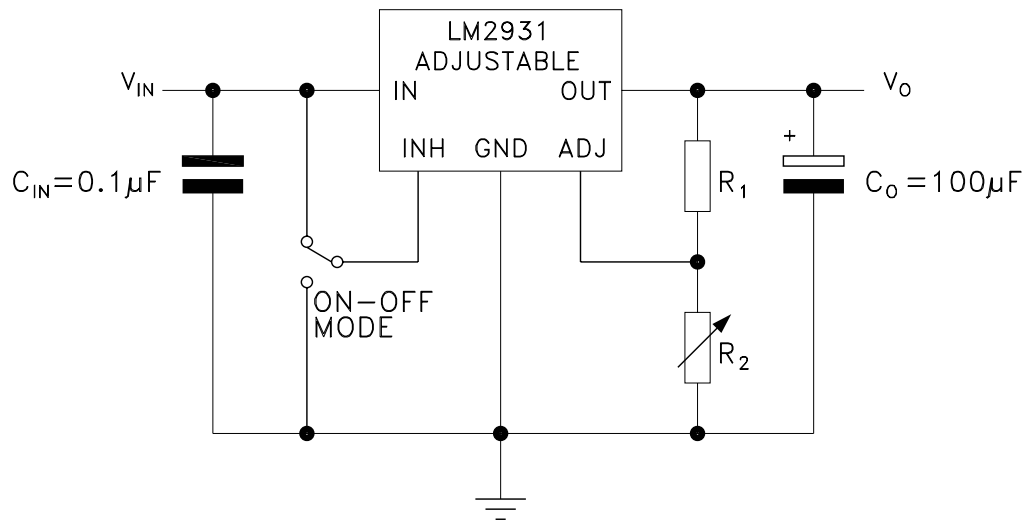

Note:  $R_1$  suggested value = 27 k $\Omega$

$$V_O = V_{REF} (R_1 + R_2) / R_1$$

Inhibit pin: regulator is enabled when  $V_{INH} < 1.2 \text{ V}$ , disabled when  $V_{INH} > 3.25 \text{ V}$

## 5 Electrical characteristics

Refer to the application circuit [Figure 4. Application circuit for fixed output](#),  $T_J = 25\text{ °C}$ ,  $C_I = 0.1\text{ }\mu\text{F}$ ,  $C_O = 100\text{ }\mu\text{F}$ ,  $V_I = 14\text{ V}$ ,  $I_O = 10\text{ mA}$ ,  $V_{INH} = 0\text{ V}$ , unless otherwise specified.

**Table 3. Electrical characteristics of LM2931A33/LM2931A33Y**

Symbol	Parameter	Test conditions	Min.	Typ.	Max.	Unit
$V_I$	Maximum operating input voltage	$I_O = 10\text{ mA}$ , $T_J = -40\text{ to }125\text{ °C}$	26			V
$V_O$	Output voltage		3.175	3.3	3.425	V
$V_O$	Output voltage	$I_O = 100\text{ mA}$ , $V_I = 6\text{ to }26\text{ V}$ , $T_J = -40\text{ to }125\text{ °C}$	3.135	3.3	3.465	V
$DV_O$	Line regulation	$V_I = 9\text{ to }16\text{ V}$		2	10	mV
		$V_I = 6\text{ to }26\text{ V}$		4	33	
$DV_O$	Load regulation	$I_O = 5\text{ to }100\text{ mA}$		10	33	mV
$V_d$	Dropout voltage <sup>(1)</sup>	$I_O = 10\text{ mA}$		90	250	mV
		$I_O = 100\text{ mA}$		250	600	
$I_d$	Quiescent current ON MODE	$I_O = 100\text{ mA}$		2.5	30	mA
	OFF MODE	$V_{INH} = 2.5\text{ V}$ , $R_{LOAD} = 330\text{ }\Omega$		0.3	1	
$I_{SC}$	Short circuit current		100	300		mA
SVR	Supply voltage rejection	$I_O = 100\text{ mA}$ , $V_I = 14 \pm 2\text{ V}$ , $f = 120\text{ Hz}$	55	78		dB
$V_{IL}$	Control input voltage low	$T_J = -40\text{ to }125\text{ °C}$		2	1.2	V
$V_{IH}$	Control input voltage high	$T_J = -40\text{ to }125\text{ °C}$	3.25	2		V
$I_{INH}$	Inhibit input current	$V_{INH} = 2.5\text{ V}$		22	50	$\mu\text{A}$
$V_I$	Transient input voltage	$R_{LOAD} = 330\text{ }\Omega$ , $T < 100\text{ ms}$	60	70		V
$V_I$	Reverse polarity input voltage	$V_O = \pm 0.3\text{ V}$ , $R_{LOAD} = 330\text{ }\Omega$	-15	-50		V
$V_I$	Reverse polarity input voltage transient	$R_{LOAD} = 330\text{ }\Omega$ , $T < 100\text{ ms}$	-50			V
eN	Output noise voltage	$B = 10\text{ Hz to }100\text{ kHz}$		330		$\mu\text{V}_{RMS}$

1.  $V_d$  measured when the output voltage has dropped 100 mV from the nominal value obtained at 14 V.

Refer to the application circuit [Figure 4. Application circuit for fixed output](#),  $T_J = 25\text{ °C}$ ,  $C_I = 0.1\text{ }\mu\text{F}$ ,  $C_O = 100\text{ }\mu\text{F}$ ,  $V_I = 14\text{ V}$ ,  $I_O = 10\text{ mA}$ ,  $V_{INH} = 0\text{ V}$ , unless otherwise specified.

**Table 4. Electrical characteristics of LM2931A50/ LM2931A50Y**

Symbol	Parameter	Test conditions	Min.	Typ.	Max.	Unit
$V_I$	Maximum operating input voltage	$I_O = 10\text{ mA}$ , $T_J = -40\text{ to }125\text{ °C}$	26			V
$V_O$	Output voltage		4.81	5	5.19	V
$V_O$	Output voltage	$I_O = 100\text{ mA}$ , $V_I = 6\text{ to }26\text{ V}$ , $T_J = -40\text{ to }125\text{ °C}$	4.75	5	5.25	V
$DV_O$	Line regulation	$V_I = 9\text{ to }16\text{ V}$		2	10	mV
		$V_I = 6\text{ to }26\text{ V}$		4	30	
$DV_O$	Load regulation	$I_O = 5\text{ to }100\text{ mA}$		15	50	mV
$V_d$	Dropout voltage <sup>(1)</sup>	$I_O = 10\text{ mA}$		90	200	mV
		$I_O = 100\text{ mA}$		250	600	

Symbol	Parameter	Test conditions	Min.	Typ.	Max.	Unit
I <sub>d</sub>	Quiescent current ON MODE	I <sub>O</sub> = 100 mA		2.5	30	mA
	OFF MODE	V <sub>INH</sub> = 2.5 V, R <sub>LOAD</sub> = 500 Ω		0.3	1	mA
I <sub>SC</sub>	Short circuit current		100	300		mA
SVR	Supply voltage rejection	I <sub>O</sub> = 100 mA, V <sub>I</sub> = 14 ± 2 V f = 120 Hz	55	75		dB
V <sub>IL</sub>	Control input voltage low	T <sub>J</sub> = -40 to 125 °C		2	1.2	V
V <sub>IH</sub>	Control input voltage high	T <sub>J</sub> = -40 to 125 °C	3.25	2		V
I <sub>INH</sub>	Inhibit input current	V <sub>INH</sub> = 2.5 V		22	50	μA
V <sub>I</sub>	Transient input voltage	R <sub>LOAD</sub> = 500 Ω, T < 100 ms	60	70		V
V <sub>I</sub>	Reverse polarity input voltage	V <sub>O</sub> = ± 0.3 V, R <sub>LOAD</sub> = 500 Ω	-15	-50		V
V <sub>I</sub>	Reverse polarity input voltage transient	R <sub>LOAD</sub> = 500 Ω, T < 100 ms	-50			V
eN	Output noise voltage	B = 10 Hz to 100 kHz		500		μV <sub>RMS</sub>

1. V<sub>d</sub> measured when the output voltage has dropped 100 mV from the nominal value obtained at 14 V.

Refer to the application circuit [Figure 5. Application circuit for adjustable output](#) with R<sub>1</sub> = 27 kΩ and R<sub>2</sub> = 40.5 kΩ, T<sub>J</sub> = 25 °C, C<sub>I</sub> = 0.1 μF, C<sub>O</sub> = 100 μF, V<sub>I</sub> = 14 V, I<sub>O</sub> = 10 mA, V<sub>INH</sub> = 0 V, unless otherwise specified.

**Table 5. Electrical characteristics of LM2931 (adjustable version)**

Symbol	Parameter	Test conditions	Min.	Typ.	Max.	Unit
V <sub>I</sub>	Maximum operating input voltage	I <sub>O</sub> = 10 mA, T <sub>J</sub> = -40 to 125 °C	26			V
V <sub>REF</sub>	Reference voltage <sup>(1)</sup>		1.14	1.2	1.26	V
V <sub>REF</sub>	Reference voltage <sup>(1)</sup>	I <sub>O</sub> = 100 mA, T <sub>J</sub> = -40 to 125 °C	1.08	1.2	1.32	V
DV <sub>O</sub>	Line regulation	V <sub>I</sub> = 3.6 to 26 V		0.6	4.5	mV
DV <sub>O</sub>	Load regulation	I <sub>O</sub> = 5 to 100 mA		9	30	mV
V <sub>d</sub>	Dropout voltage <sup>(2)</sup>	I <sub>O</sub> = 10 mA		90	200	mV
		I <sub>O</sub> = 100 mA		250	600	
I <sub>d</sub>	Quiescent current ON MODE	I <sub>O</sub> = 100 mA		2.5	30	mA
	OFF MODE	V <sub>INH</sub> = 2.5 V, R <sub>LOAD</sub> = 300 Ω		0.3	1	mA
I <sub>SC</sub>	Short circuit current		100	300		mA
SVR	Supply voltage rejection	I <sub>O</sub> = 100 mA, V <sub>I</sub> = 14 ± 2 V f = 120 Hz	55	80		dB
V <sub>IL</sub>	Control input voltage low	T <sub>J</sub> = -40 to 125 °C		2	1.2	V
V <sub>IH</sub>	Control input voltage high	T <sub>J</sub> = -40 to 125 °C	3.25	2		V
I <sub>INH</sub>	Inhibit input current	V <sub>INH</sub> = 2.5 V		22	50	μA
V <sub>I</sub>	Transient input voltage	R <sub>LOAD</sub> = 300 Ω, T < 100 ms	60	70		V
V <sub>I</sub>	Reverse polarity input voltage	V <sub>O</sub> = ± 0.3 V, R <sub>LOAD</sub> = 300 Ω	-15	-50		V
V <sub>I</sub>	Reverse polarity input voltage transient	R <sub>LOAD</sub> = 300 Ω, T < 100 ms	-50			V
eN	Output noise voltage	B = 10 Hz to 100 kHz		330		μV <sub>RMS</sub>

1. Reference voltage is measured from V<sub>OUT</sub> to ADJ pin.

2. V<sub>d</sub> measured when the output voltage has dropped 100 mV from the nominal value obtained at 14 V.

## 6 Typical characteristics

Unless otherwise specified  $C_I = 0.1 \mu\text{F}$ ,  $C_O = 100 \mu\text{F}$ .

**Figure 6. Output voltage vs temperature**

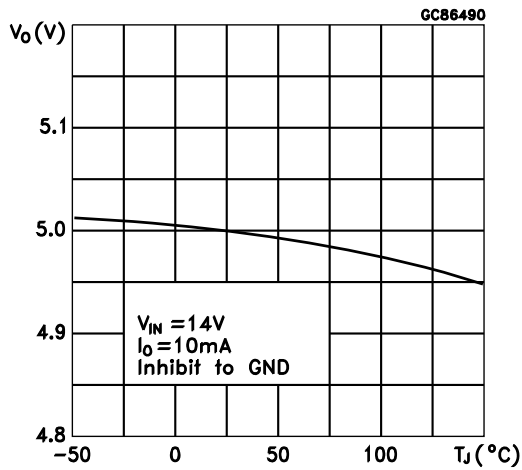

AMG110720161200MT

**Figure 7. Output voltage vs temperature**

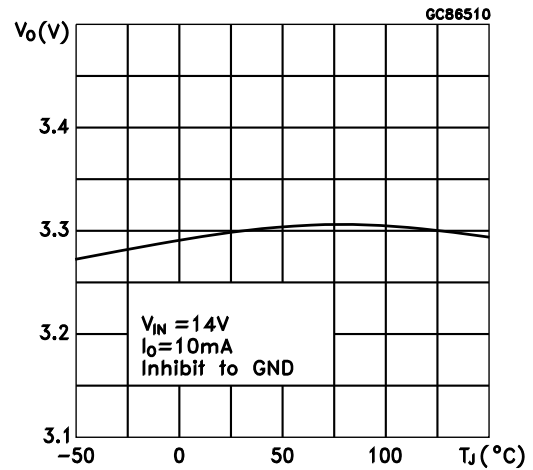

AMG110720161201MT

**Figure 8. Reference voltage vs temperature**

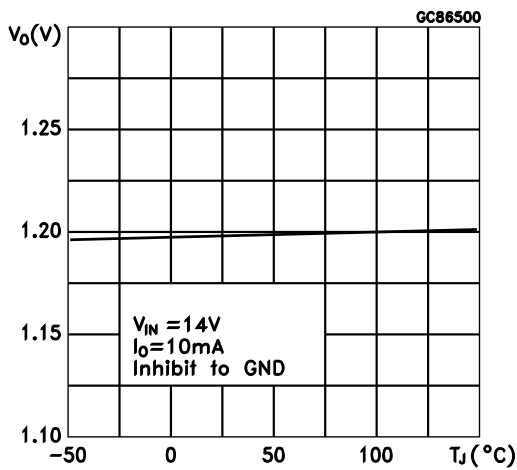

AMG110720161202MT

**Figure 9. Line regulation vs temperature**

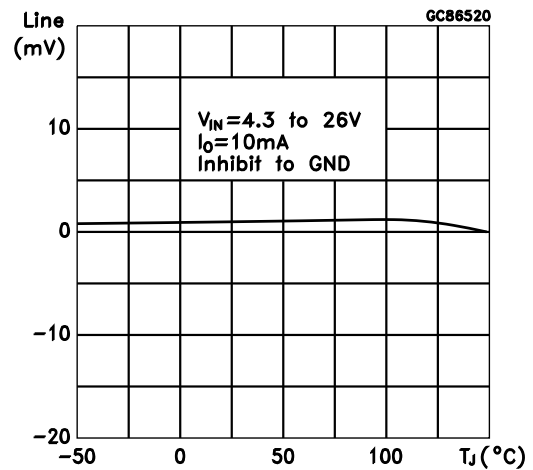

AMG110720161203MT

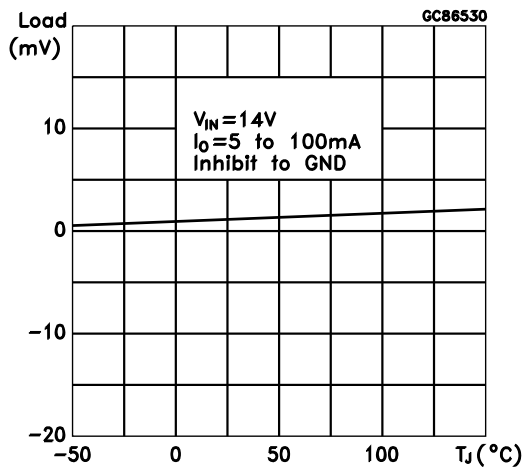
**Figure 10. Load regulation vs temperature**

AMG110720161204MT

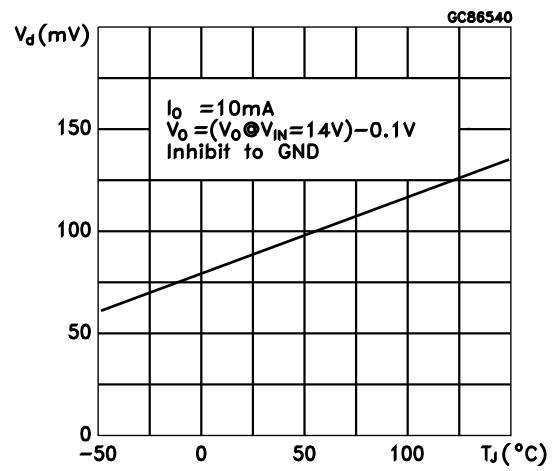
**Figure 11. Dropout voltage vs temperature**

AMG110720161205MT

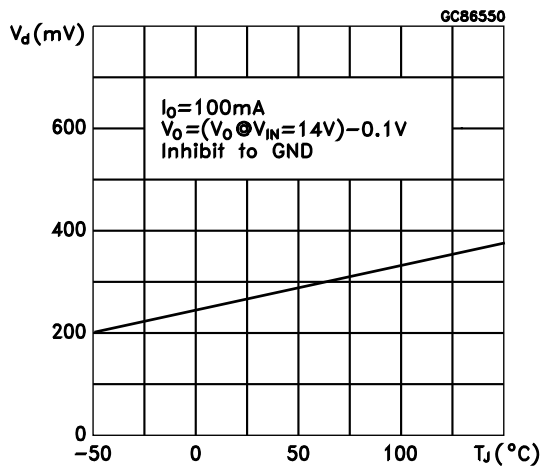
**Figure 12. Dropout voltage vs temperature**

AMG110720161206MT

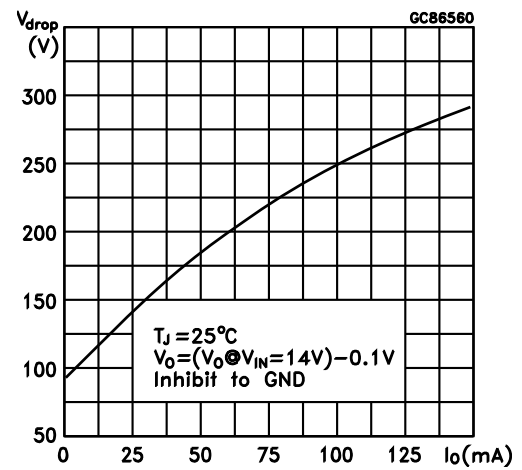
**Figure 13. Dropout voltage vs output current**

AMG110720161207MT

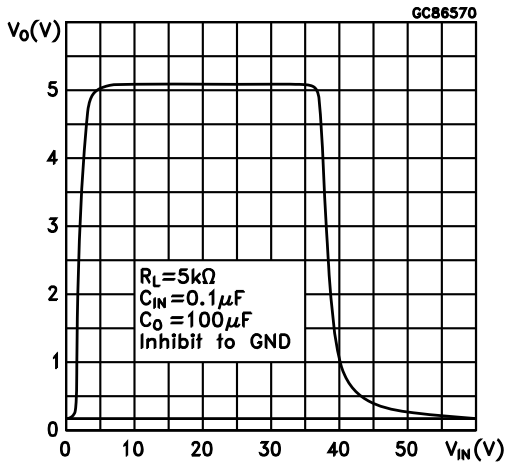
**Figure 14. Output voltage vs input voltage**

AMG110720161208MT

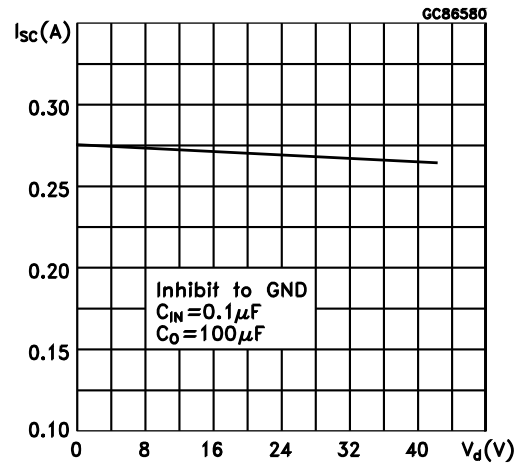
**Figure 15. Short circuit current vs drop voltage**

AMG110720161209MT

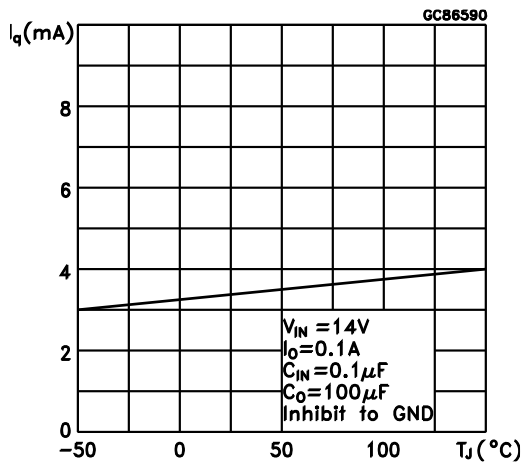
**Figure 16. Quiescent current vs temperature**

AMG110720161210MT

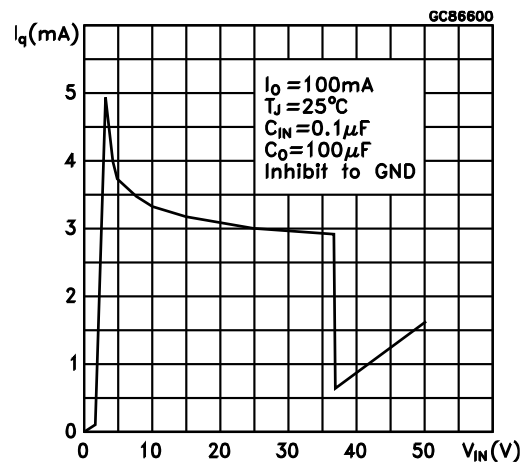
**Figure 17. Quiescent current vs input voltage**

AMG110720161211MT

**Figure 18. Quiescent current vs output current**

**Figure 19. Supply voltage rejection vs temperature**

**Figure 20. Supply voltage rejection vs frequency**

**Figure 21. Supply voltage rejection vs output current**

**Figure 22. Stability vs CO**

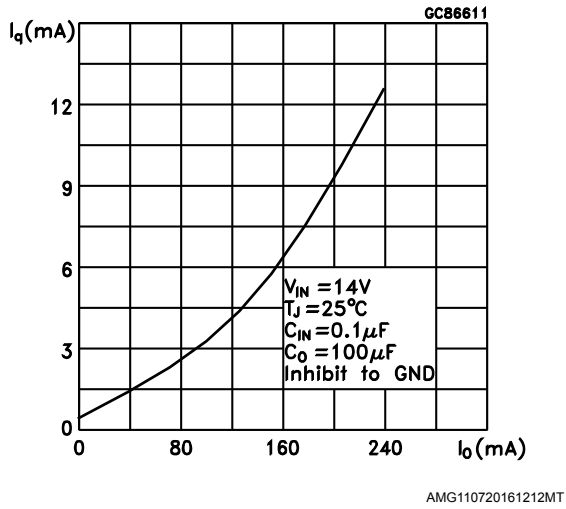
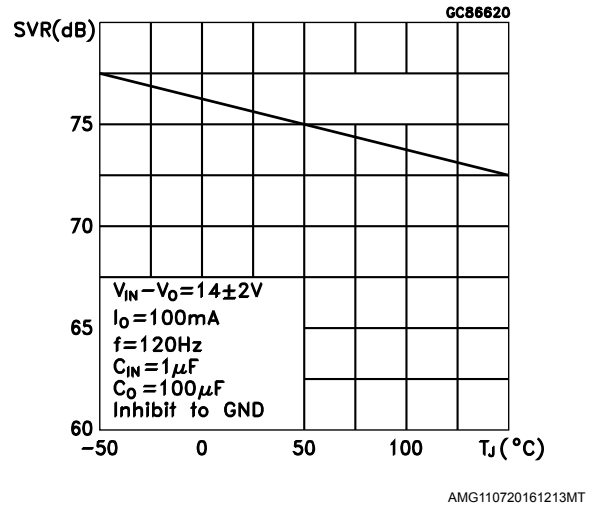
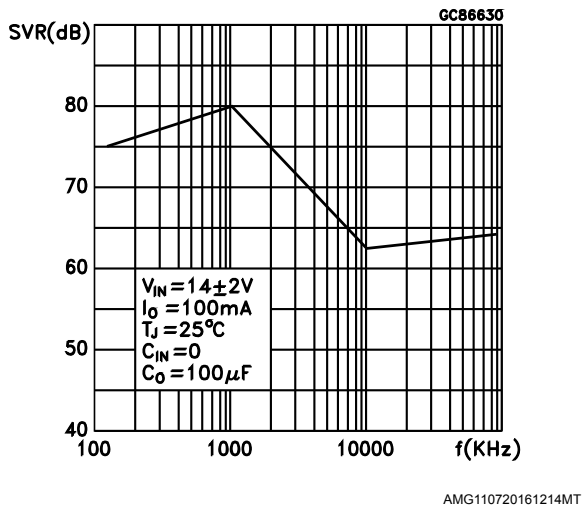
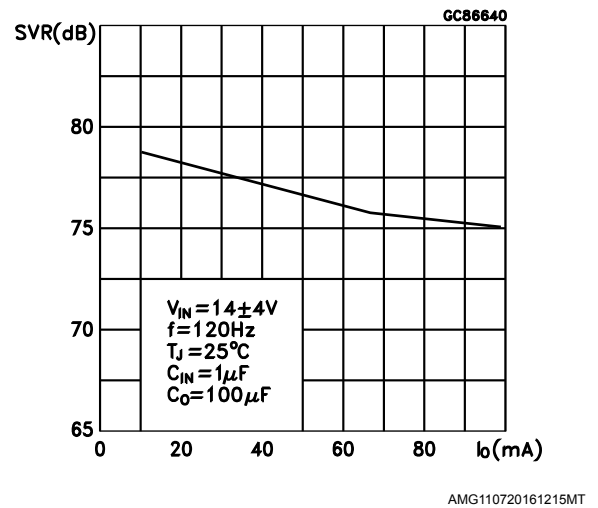
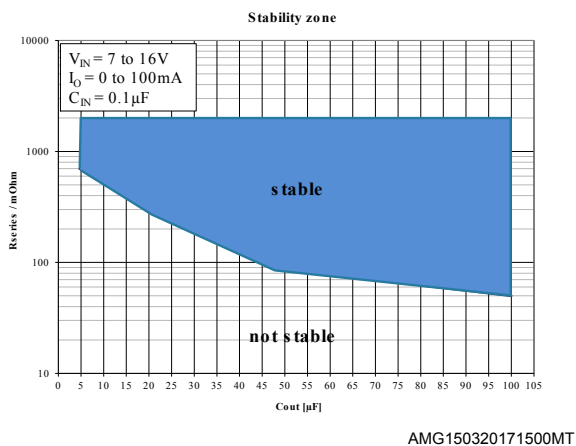
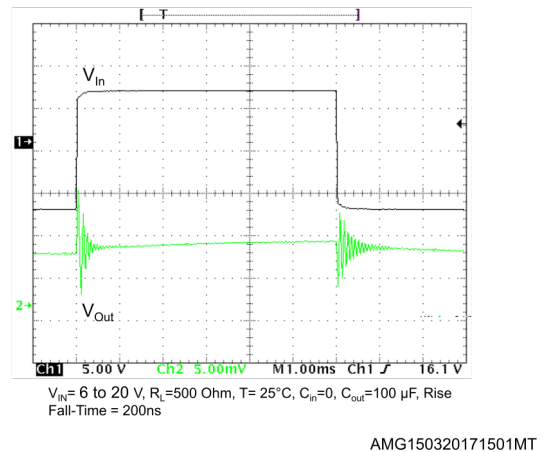
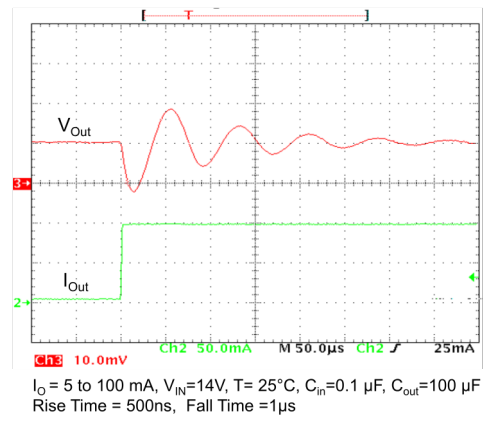
**Figure 23. Line transient**

Figure 24. Load transient



AMG150320171502MT

## **7** Package information

---

In order to meet environmental requirements, ST offers these devices in different grades of ECOPACK® packages, depending on their level of environmental compliance. ECOPACK® specifications, grade definitions and product status are available at: [www.st.com](http://www.st.com). ECOPACK® is an ST trademark.

## 7.1 DPAK package information

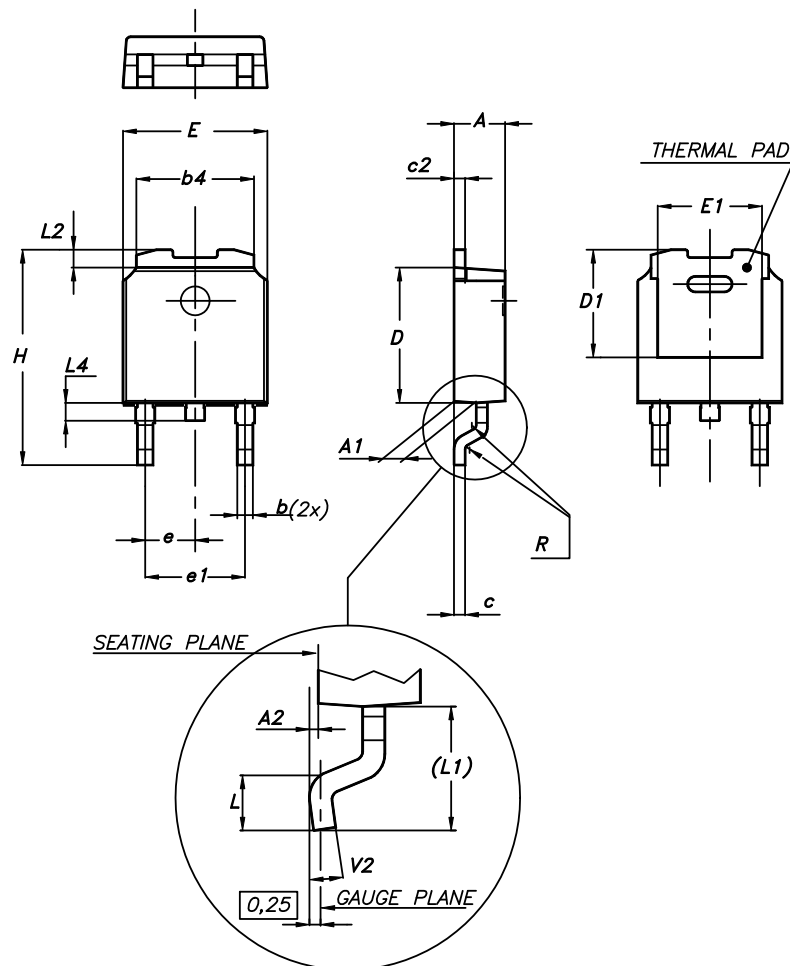
**Figure 25. DPAK package outline**

0068772\_A\_21

**Table 6. DPAK mechanical data**

Dim.	mm		
	Min.	Typ.	Max.
A	2.20		2.40
A1	0.90		1.10
A2	0.03		0.23
b	0.64		0.90
b4	5.20		5.40
c	0.45		0.60
c2	0.48		0.60
D	6.00		6.20

Dim.	mm		
	Min.	Typ.	Max.
D1		5.10	
E	6.40		6.60
E1		4.70	
e		2.28	
e1	4.40		4.60
H	9.35		10.10
L	1.00		1.50
(L1)		2.80	
L2		0.80	
L4	0.60		1.00
R		0.20	
V2	0°		8°

**Figure 26. DPAK recommended footprint (dimensions are in mm)**

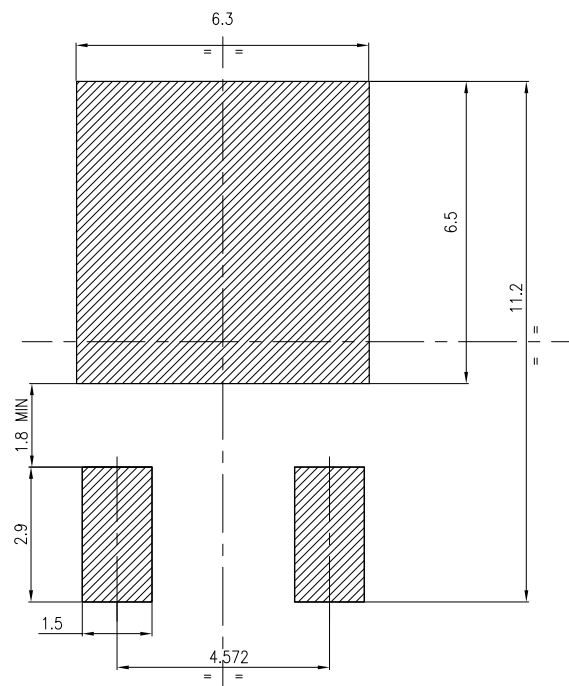

FP\_0068772\_24

## 7.2 DPAK packing information

**Figure 27. DPAK tape outline**

Figure 28. DPAK reel outline



### 7.3 SO8 package information

Figure 29. SO-8 package outline

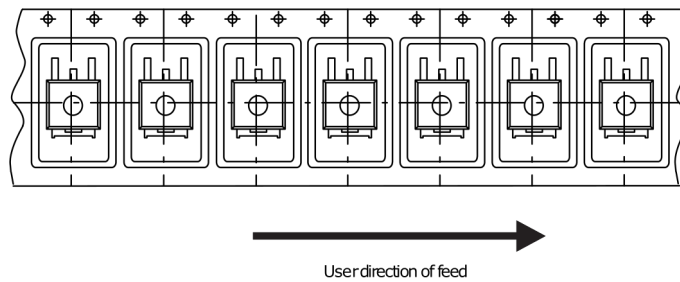
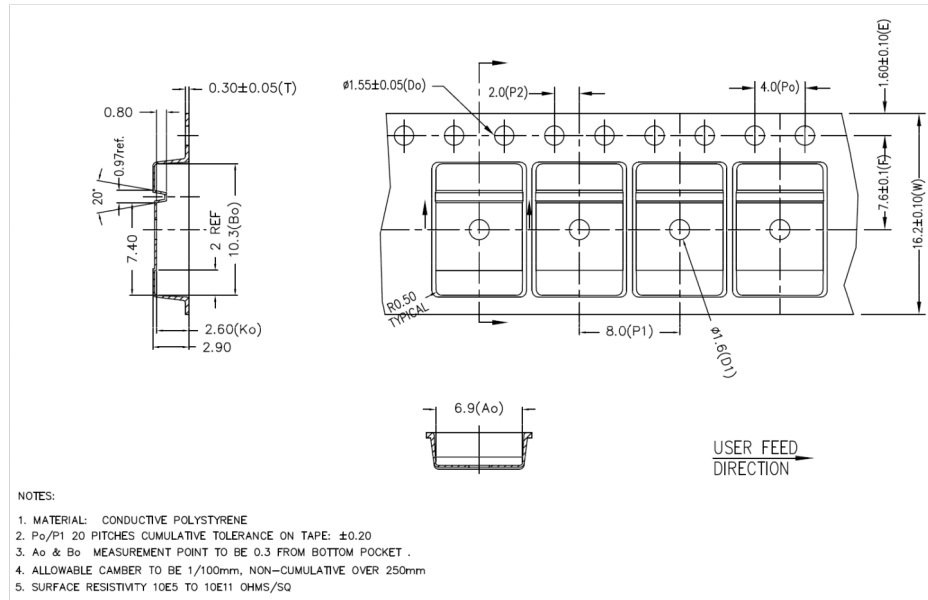
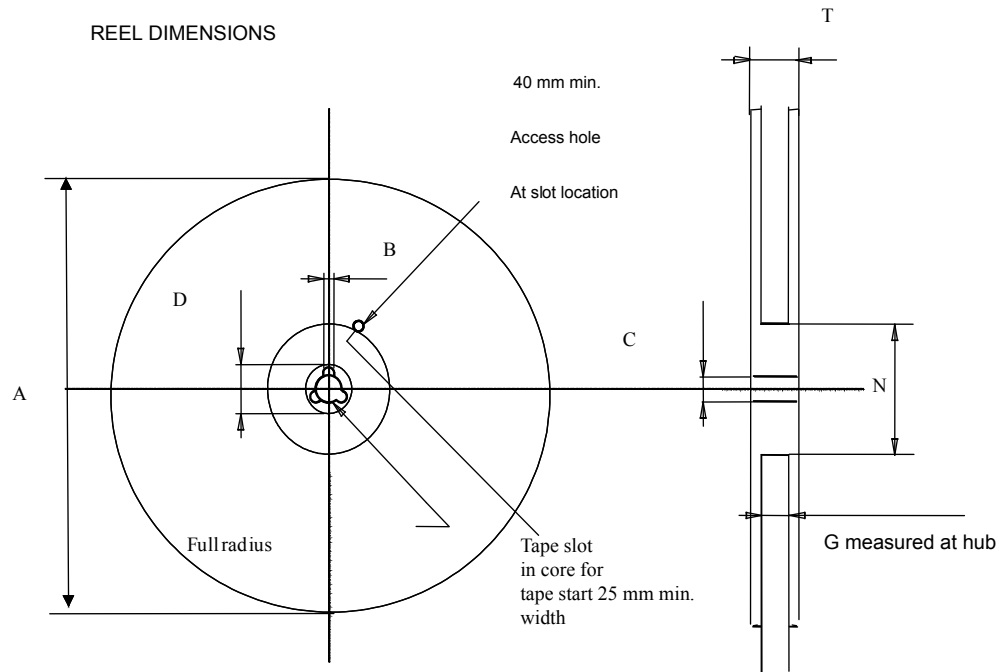
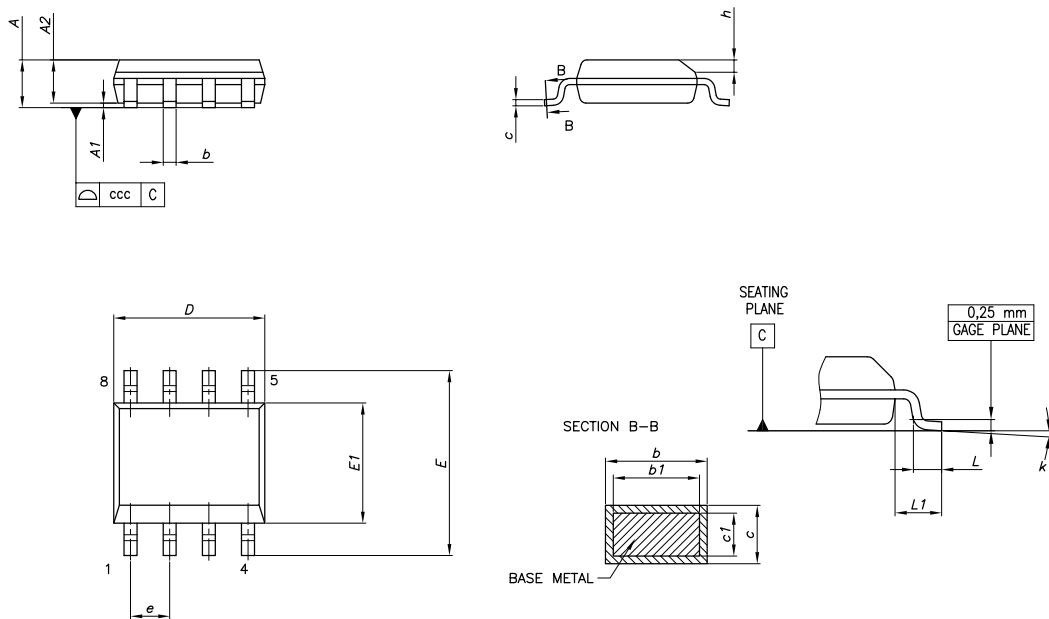

0016023\_I

Table 7. SO-8 mechanical data

Dim.	mm		
	Min.	Typ.	Max.
A			1.75
A1	0.10		0.25
A2	1.25		
b	0.28		0.48
c	0.17		0.23
D	4.80	4.90	5.00
E	5.80	6.00	6.20
E1	3.80	3.90	4.00
e		1.27	
h	0.25		0.50
L	0.40		1.27
L1		1.04	
k	0°		8°
ccc			0.10

Figure 30. SO-8 recommended footprint

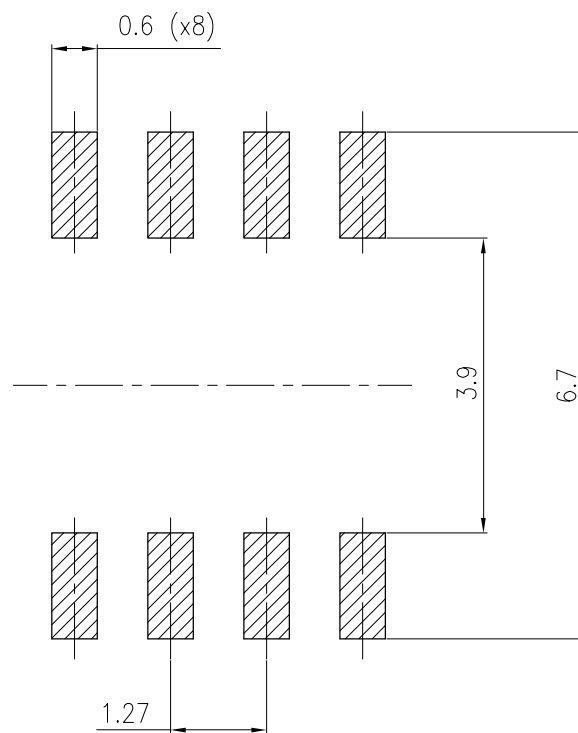

0016023\_I

## 7.4 SO-8 packing information

Figure 31. SO-8 tape and reel outline

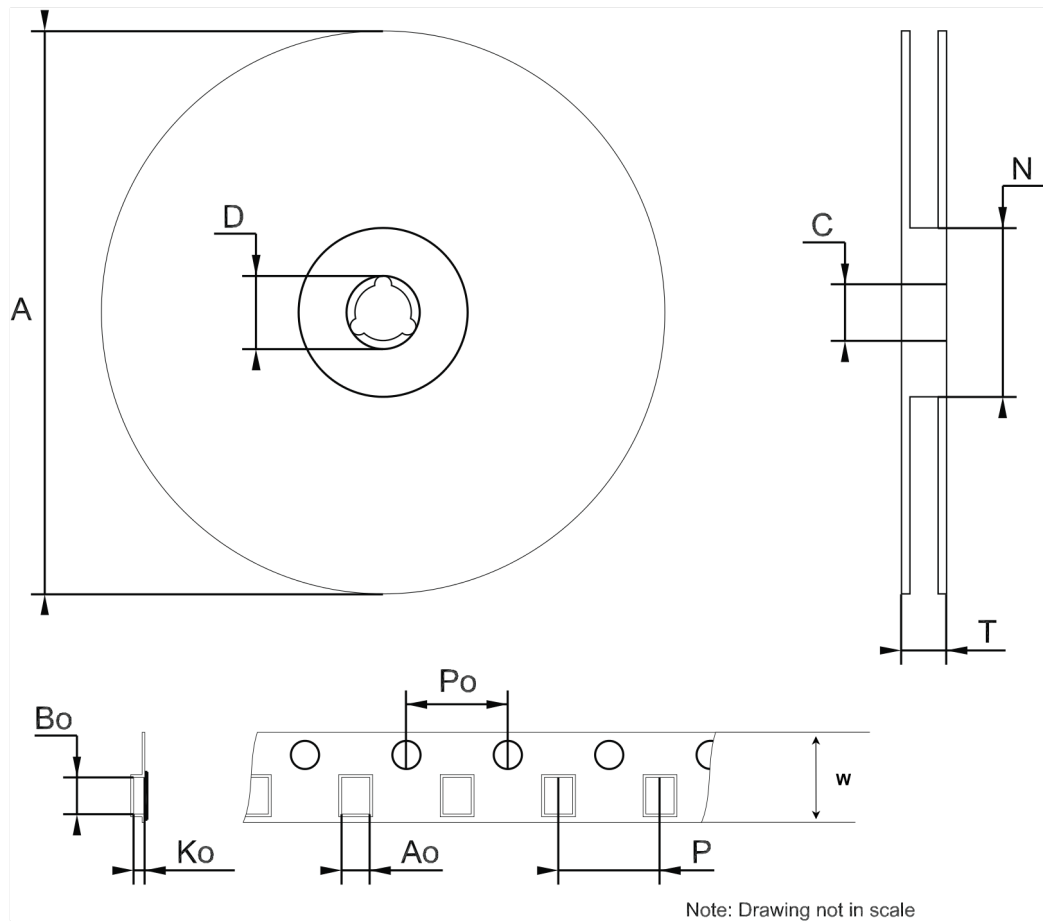
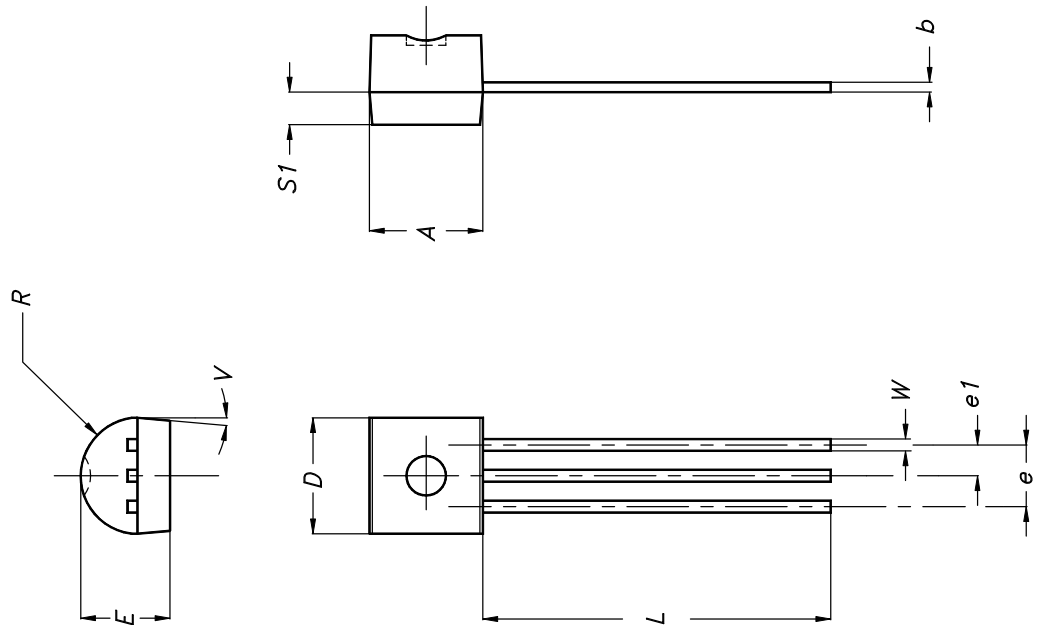

Table 8. SO-8 mechanical data

Dim.	mm		
	Min.	Typ.	Max.
A			330
C	12.8		13.2
D	20.2		
N	50		
T			22.4
Ao	6.4	6.5	6.6
Bo	5.2		5.4
Ko	2.1		2.3
Po	3.9		4.1
P	7.9		8.1
W	11.7	12.0	12.3

**7.5 TO-92 package information**
**Figure 32. TO-92 package outline**

0102782\_E

**Table 9. TO-92 mechanical data**

Dim.	mm		
	Min.	Typ.	Max.
A	4.32		4.95
b	0.36		0.51
D	4.45		4.95
E	3.30		3.94
e	2.41		2.67
e1	1.14		1.40
L	12.70		15.49
R	2.16		2.41
S1	0.92		1.52
W	0.41		0.56
V		5°	

## 8 Ordering informations

**Table 10. Order code**

DPAK		TO-92 (bag)	SO-8	Output voltages
AG	Standard			
LM2931ADT33RY <sup>(1)</sup>			LM2931AD33R	3.3 V
LM2931ADT50RY <sup>(1)</sup>	LM2931ADT50R	LM2931AZ50R	LM2931AD50R	5.0 V
			LM2931D-R	2.5 to 26 V

1. Qualified and characterized according to AEC Q100 and Q003 or equivalent, advanced screening according to AEC Q001 and Q002 or equivalent .

## Revision history

**Table 11. Document revision history**

Date	Revision	Changes
21-Jun-2004	12	Document updated.
16-Jun-2006	13	Order codes updated.
27-Jul-2007	14	Added Table 1 in cover page.
21-Aug-2007	15	Added root part number - (see Table 1).
22-Nov-2007	16	Modified: Table 1.
11-Feb-2008	17	Modified: Table 1 on page 1.
10-Jul-2008	18	Removed package TO-220, modified Table 1 on page 1.
26-May-2010	19	Modified: $V_I$ values Table 4 on page 6, Table 5 on page 7 and Table 6 on page 8.
02-Nov-2011	20	Modified: Figure 4 on page 6. Added: (*) ADJ pin on the Adjustable version, Not Connected in the fixed output version. on page 4 and Inhibit pin: regulator is enabled when $V_{INH} < 1.2$ V , disabled when $V_{INH} > 3.25$ V on page 6.
09-Apr-2014	21	Part numbers LM2931XX, LM2931AXX33 and LM2931AXX50 changed to LM2931. Updated the description in cover page Section 2: Pin configuration and Section 7: Package information. Added Section 8: Revision history. Minor text changes.
16-Mar-2017	22	Updated features in cover page, removed Table 1. Device summary from cover page, Table 3: "Electrical characteristics of LM2931A33/LM2931A33Y" , Table 4: "Electrical characteristics of LM2931A50/ LM2931A50Y" and Table 5: "Electrical characteristics of LM2931 (adjustable version)". Updated Section 7: "Package information". Added Section 8: "Ordering information". Minor text changes.
23-Feb-2018	23	Updated <a href="#">Figure 5. Application circuit for adjustable output.</a>

## Contents

<b>1</b>	<b>Diagram</b> .....	<b>2</b>
<b>2</b>	<b>Pin configuration</b> .....	<b>3</b>
<b>3</b>	<b>Maximum ratings</b> .....	<b>4</b>
<b>4</b>	<b>Application circuits</b> .....	<b>5</b>
<b>5</b>	<b>Electrical characteristics</b> .....	<b>6</b>
<b>6</b>	<b>Typical characteristics</b> .....	<b>8</b>
<b>7</b>	<b>Package information</b> .....	<b>13</b>
<b>7.1</b>	DPAK package information .....	14
<b>7.2</b>	DPAK packing information .....	15
<b>7.3</b>	SO8 package information .....	17
<b>7.4</b>	SO-8 packing information .....	18
<b>7.5</b>	TO-92 package information .....	19
<b>8</b>	<b>Ordering informations</b> .....	<b>21</b>
	<b>Revision history</b> .....	<b>22</b>
	<b>Contents</b> .....	<b>23</b>
	<b>List of tables</b> .....	<b>24</b>
	<b>List of figures</b> .....	<b>25</b>
	<b>Disclaimer</b> .....	<b>26</b>

## List of tables

<b>Table 1.</b>	Absolute maximum ratings . . . . .	4
<b>Table 2.</b>	Thermal data . . . . .	4
<b>Table 3.</b>	Electrical characteristics of LM2931A33/LM2931A33Y . . . . .	6
<b>Table 4.</b>	Electrical characteristics of LM2931A50/ LM2931A50Y . . . . .	6
<b>Table 5.</b>	Electrical characteristics of LM2931 (adjustable version) . . . . .	7
<b>Table 6.</b>	DPAK mechanical data . . . . .	14
<b>Table 7.</b>	SO-8 mechanical data . . . . .	18
<b>Table 8.</b>	SO-8 mechanical data . . . . .	19
<b>Table 9.</b>	TO-92 mechanical data . . . . .	20
<b>Table 10.</b>	Order code . . . . .	21
<b>Table 11.</b>	Document revision history . . . . .	22

## List of figures

Figure 2.	Schematic diagram . . . . .	2
Figure 3.	Pin connections (top view) . . . . .	3
Figure 4.	Application circuit for fixed output . . . . .	5
Figure 5.	Application circuit for adjustable output . . . . .	5
Figure 6.	Output voltage vs temperature . . . . .	8
Figure 7.	Output voltage vs temperature . . . . .	8
Figure 8.	Reference voltage vs temperature. . . . .	8
Figure 9.	Line regulation vs temperature . . . . .	8
Figure 10.	Load regulation vs temperature. . . . .	9
Figure 11.	Dropout voltage vs temperature . . . . .	9
Figure 12.	Dropout voltage vs temperature . . . . .	9
Figure 13.	Dropout voltage vs output current . . . . .	9
Figure 14.	Output voltage vs input voltage . . . . .	10
Figure 15.	Short circuit current vs drop voltage. . . . .	10
Figure 16.	Quiescent current vs temperature . . . . .	10
Figure 17.	Quiescent current vs input voltage . . . . .	10
Figure 18.	Quiescent current vs output current . . . . .	11
Figure 19.	Supply voltage rejection vs temperature. . . . .	11
Figure 20.	Supply voltage rejection vs frequency . . . . .	11
Figure 21.	Supply voltage rejection vs output current . . . . .	11
Figure 22.	Stability vs $C_O$ . . . . .	11
Figure 23.	Line transient . . . . .	11
Figure 24.	Load transient . . . . .	12
Figure 25.	DPAK package outline . . . . .	14
Figure 26.	DPAK recommended footprint (dimensions are in mm). . . . .	15
Figure 27.	DPAK tape outline. . . . .	16
Figure 28.	DPAK reel outline . . . . .	17
Figure 29.	SO-8 package outline . . . . .	17
Figure 30.	SO-8 recommended footprint . . . . .	18
Figure 31.	SO-8 tape and reel outline . . . . .	19
Figure 32.	TO-92 package outline . . . . .	20

**IMPORTANT NOTICE – PLEASE READ CAREFULLY**

STMicroelectronics NV and its subsidiaries (“ST”) reserve the right to make changes, corrections, enhancements, modifications, and improvements to ST products and/or to this document at any time without notice. Purchasers should obtain the latest relevant information on ST products before placing orders. ST products are sold pursuant to ST’s terms and conditions of sale in place at the time of order acknowledgement.

Purchasers are solely responsible for the choice, selection, and use of ST products and ST assumes no liability for application assistance or the design of Purchasers’ products.

No license, express or implied, to any intellectual property right is granted by ST herein.

Resale of ST products with provisions different from the information set forth herein shall void any warranty granted by ST for such product.



ST and the ST logo are trademarks of ST. All other product or service names are the property of their respective owners.

Information in this document supersedes and replaces information previously supplied in any prior versions of this document.

© 2018 STMicroelectronics – All rights reserved

## Looking for pricing, stock, or lifecycle information?

Click below to explore more details on WIN SOURCE:

-  [View LM2931BV50 on WIN SOURCE](#)
-  [STMicroelectronics](#) Information

## Optimize Your Supply Chain with WIN SOURCE Solutions

-  Global Sourcing Solution
-  Obsolete Management
-  Cost Control Management
-  Shortage Management
-  Alternative Solution
-  Excess Inventory Management