



# THE DATASHEET OF LM317LM/NOPB



## LM317L-N Wide $V_{IN}$ 100-mA Adjustable Voltage Regulator

### 1 Features

- Adjustable Output Down to 1.2 V
- 100-mA Output Current
- Capable of Handling up to 40V  $V_{IN}$
- Line Regulation Typically 0.01% /V
- Load Regulation Typically 0.1% /A
- No Output Capacitor Required (†)
- Current Limit Constant With Temperature
- Eliminates the Need to Stock Many Voltages
- Standard 3-Lead Transistor Package
- 80-dB Ripple Rejection
- Available in 3-Pin TO-92, 8-Pin SOIC, or 6-pin DSBGA Packages
- Output is Short-Circuit Protected
- See AN-1112 (SNVA009) for DSBGA Considerations

### 2 Applications

- Automotive LED Lighting
- Battery Chargers
- Post Regulation for Switching Supplies
- Constant-Current Regulators
- Microprocessor Supplies

#### Schematic Diagram

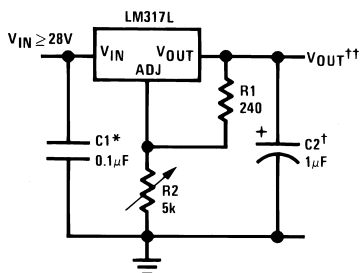

Full output current not available at high input-output voltages

†Optional—improves transient response

\*Needed if device is more than 6 inches from filter capacitors

$$\dagger\dagger V_{OUT} = 1.25V \left( 1 + \frac{R_2}{R_1} \right) + I_{ADJ} (R_2)$$

### 3 Description

The LM317L-N is an adjustable positive voltage regulator capable of supplying 100 mA over a 1.2-V to 37-V output range. The LM317L-N is easy to use and requires only two external resistors to set the output voltage. Both line and load regulation are better than standard fixed regulators. The LM317L-N is available packaged in a standard, easy-to-use TO-92 transistor package.

The LM317L-N offers full overload protection. Included on the chip are current limit, thermal overload protection, and safe area protection. Normally, no capacitors are required unless the device is situated more than 6 inches from the input filter capacitors, in which case an input bypass is required.

The LM317L-N uses *floating* topology and sees only the input-to-output differential voltage, therefore supplies of several hundred volts can be regulated, provided the maximum input-to-output differential is not exceeded. The device makes a simple adjustable switching regulator, a programmable output regulator, or by connecting a fixed resistor between the adjustment and output, the LM317L-N can be used as a precision current regulator.

The LM317L-N is available in a standard 3-pin TO-92 transistor package, the 8-pin SOIC package, and 6-pin DSBGA package. The LM317L-N is rated for operation over a  $-40^{\circ}\text{C}$  to  $125^{\circ}\text{C}$  range.

#### Device Information<sup>(1)</sup>

PART NUMBER	PACKAGE	BODY SIZE (NOM)
LM317L-N	TO-92 (3)	4.30 mm × 4.30 mm
	SOIC (8)	3.91 mm × 4.90 mm
	DSBGA (6)	1.68 mm × 1.019 mm

(1) For all available packages, see the orderable addendum at the end of the data sheet.



## Table of Contents

<b>1 Features</b> .....	<b>1</b>	7.4 Device Functional Modes.....	<b>10</b>
<b>2 Applications</b> .....	<b>1</b>	<b>8 Application and Implementation</b> .....	<b>12</b>
<b>3 Description</b> .....	<b>1</b>	8.1 Application Information.....	<b>12</b>
<b>4 Revision History</b> .....	<b>2</b>	8.2 Typical Applications .....	<b>12</b>
<b>5 Pin Configuration and Functions</b> .....	<b>3</b>	<b>9 Power Supply Recommendations</b> .....	<b>25</b>
<b>6 Specifications</b> .....	<b>4</b>	<b>10 Layout</b> .....	<b>25</b>
6.1 Absolute Maximum Rating .....	4	10.1 Layout Guidelines .....	25
6.2 ESD Ratings.....	4	10.2 Layout Examples.....	25
6.3 Recommended Operating Conditions.....	4	10.3 Thermal Considerations.....	26
6.4 Thermal Information .....	4	<b>11 Device and Documentation Support</b> .....	<b>27</b>
6.5 Electrical Characteristics .....	5	11.1 Documentation Support .....	27
6.6 Typical Characteristics.....	6	11.2 Community Resources.....	27
<b>7 Detailed Description</b> .....	<b>8</b>	11.3 Trademarks .....	27
7.1 Overview .....	8	11.4 Electrostatic Discharge Caution.....	27
7.2 Functional Block Diagram .....	9	11.5 Glossary .....	27
7.3 Feature Description.....	10	<b>12 Mechanical, Packaging, and Orderable Information</b> .....	<b>27</b>

## 4 Revision History

NOTE: Page numbers for previous revisions may differ from page numbers in the current version.

<b>Changes from Revision K (September 2015) to Revision L</b>	<b>Page</b>
• Changed TO-92 package view from top to bottom view .....	<b>3</b>
• Changed DSBGA package view from bump side down to top view .....	<b>3</b>
• Removed duplicate <i>Protection Diodes</i> section and <i>Regulator With Protection Diodes</i> image from the <i>Device Functional Modes</i> section.....	<b>10</b>

<b>Changes from Revision J (March 2013) to Revision K</b>	<b>Page</b>
• Added <i>ESD Ratings</i> table, <i>Feature Description</i> section, <i>Device Functional Modes</i> , <i>Application and Implementation</i> section, <i>Power Supply Recommendations</i> section, <i>Layout</i> section, <i>Device and Documentation Support</i> section, and <i>Mechanical, Packaging, and Orderable Information</i> section. ....	<b>1</b>

<b>Changes from Revision I (March 2013) to Revision J</b>	<b>Page</b>
• Changed layout of National Data Sheet to TI format .....	<b>25</b>

## 5 Pin Configuration and Functions

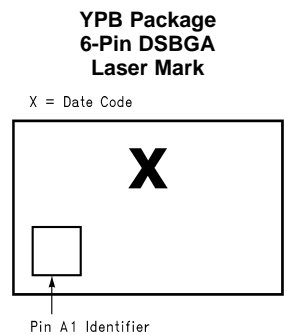
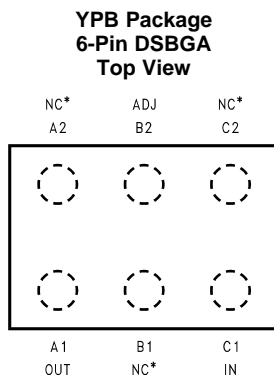
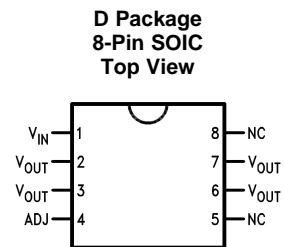
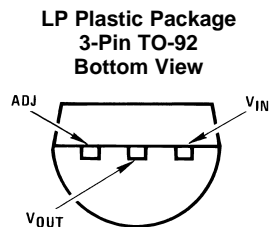

### Pin Functions

NAME	PIN			I/O	DESCRIPTION
	TO-92	SOIC	DSBGA		
VIN	3	1	C1	I	Supply input pin
VOUT	2	2, 3, 6, 7	A1	O	Voltage output pin
ADJ	1	4	B2	I	Output voltage adjustment pin. Connect to a resistor divider to set $V_O$ .
NC	—	5, 8	B1, A2, C2	—	No connection

## 6 Specifications

### 6.1 Absolute Maximum Rating <sup>(1)(2)</sup>

	MIN	MAX	UNIT
Power dissipation	Internally Limited		
Input-output voltage differential		40	V
Operating junction temperature	-40	125	°C
Lead temperature (soldering, 4 seconds)		260	°C
Storage temperature, $T_{stg}$	-55	150	°C

- (1) Stresses beyond those listed under *Absolute Maximum Ratings* may cause permanent damage to the device. These are stress ratings only, which do not imply functional operation of the device at these or any other conditions beyond those indicated under *Recommended Operating Conditions*. Exposure to absolute-maximum-rated conditions for extended periods may affect device reliability.
- (2) If Military/Aerospace specified devices are required, contact the Texas Instruments Sales Office/Distributors for availability and specifications.

### 6.2 ESD Ratings

	VALUE	UNIT
$V_{(ESD)}$ Electrostatic discharge Human-body model (HBM), per ANSI/ESDA/JEDEC JS-001 <sup>(1)</sup>	±2000	V

- (1) JEDEC document JEP155 states that 500-V HBM allows safe manufacturing with a standard ESD control process. Pins listed as ±2000 V may actually have higher performance.

### 6.3 Recommended Operating Conditions

over operating free-air temperature range (unless otherwise noted)

	MIN	MAX	UNIT
Operating temperature	-40	125	°C

### 6.4 Thermal Information

THERMAL METRIC <sup>(1)</sup>	LM317L-N				UNIT
	TO-92		SOIC	DSBGA	
	3 PINS		8 PINS	6 PINS	
	0.4-in Leads	0.125-in Leads			
$R_{\theta JA}$ Junction-to-ambient thermal resistance	180	160	165	290	°C/W
$R_{\theta JC(top)}$ Junction-to-case (top) thermal resistance	—	80.6	—	—	°C/W
$R_{\theta JB}$ Junction-to-board thermal resistance	—	—	—	—	°C/W
$\psi_{JT}$ Junction-to-top characterization parameter	—	24.7	—	—	°C/W
$\psi_{JB}$ Junction-to-board characterization parameter	—	135.8	—	—	°C/W
$R_{\theta JC(bot)}$ Junction-to-case (bottom) thermal resistance	—	—	—	—	°C/W

- (1) For more information about traditional and new thermal metrics, see the *Semiconductor and IC Package Thermal Metrics* application report, [SPRA953](#).

## 6.5 Electrical Characteristics <sup>(1)</sup>

PARAMETER	TEST CONDITIONS	MIN	TYP	MAX	UNIT
Line regulation	$T_J = 25^\circ\text{C}$ , $3\text{ V} \leq (V_{IN} - V_{OUT}) \leq 40\text{ V}$ , $I_L \leq 20\text{ mA}$ <sup>(2)</sup>		0.01	0.04	%/V
Load regulation	$T_J = 25^\circ\text{C}$ , $5\text{ mA} \leq I_{OUT} \leq I_{MAX}$ <sup>(2)</sup>		0.1%	0.5%	
Thermal regulation	$T_J = 25^\circ\text{C}$ , 10-ms Pulse		0.04	0.2	%/W
Adjustment pin current			50	100	$\mu\text{A}$
Adjustment pin current change	$5\text{ mA} \leq I_L \leq 100\text{ mA}$ $3\text{ V} \leq (V_{IN} - V_{OUT}) \leq 40\text{ V}$ , $P \leq 625\text{ mW}$		0.2	5	$\mu\text{A}$
Reference voltage	$3\text{ V} \leq (V_{IN} - V_{OUT}) \leq 40\text{ V}$ <sup>(3)</sup> $5\text{ mA} \leq I_{OUT} \leq 100\text{ mA}$ , $P \leq 625\text{ mW}$	1.2	1.25	1.3	V
Line regulation	$3\text{ V} \leq (V_{IN} - V_{OUT}) \leq 40\text{ V}$ , $I_L \leq 20\text{ mA}$ <sup>(2)</sup>		0.02	0.07	%/V
Load regulation	$5\text{ mA} \leq I_{OUT} \leq 100\text{ mA}$ <sup>(2)</sup>		0.3%	1.5%	
Temperature stability	$T_{MIN} \leq T_J \leq T_{MAX}$		0.65%		
Minimum load current	$(V_{IN} - V_{OUT}) \leq 40\text{ V}$		3.5	5	mA
	$3\text{ V} \leq (V_{IN} - V_{OUT}) \leq 15\text{ V}$		1.5	2.5	
Current limit	$3\text{ V} \leq (V_{IN} - V_{OUT}) \leq 13\text{ V}$	100	200	300	mA
	$(V_{IN} - V_{OUT}) = 40\text{ V}$	25	50	150	
RMS output noise, % of $V_{OUT}$	$T_J = 25^\circ\text{C}$ , $10\text{ Hz} \leq f \leq 10\text{ kHz}$		0.003%		
Ripple rejection ratio	$V_{OUT} = 10\text{ V}$ , $f = 120\text{ Hz}$ , $C_{ADJ} = 0$		65		dB
	$C_{ADJ} = 10\text{ }\mu\text{F}$	66	80		
Long-term stability	$T_J = 125^\circ\text{C}$ , 1000 Hours		0.3%	1%	

- (1) Unless otherwise noted, these specifications apply:  $-25^\circ\text{C} \leq T_J \leq 125^\circ\text{C}$  for the LM317L-N;  $V_{IN} - V_{OUT} = 5\text{ V}$  and  $I_{OUT} = 40\text{ mA}$ . Although power dissipation is internally limited, these specifications are applicable for power dissipations up to 625 mW.  $I_{MAX}$  is 100 mA.
- (2) Regulation is measured at constant junction temperature, using pulse testing with a low duty cycle. Changes in output voltage due to heating effects are covered under the specification for thermal regulation.
- (3) Thermal resistance of the TO-92 package is  $180^\circ\text{C/W}$  junction to ambient with 0.4-inch leads from a PCB and  $160^\circ\text{C/W}$  junction to ambient with 0.125-inch lead length to PCB.

## 6.6 Typical Characteristics

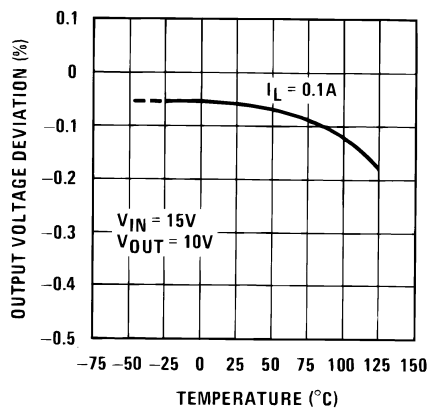
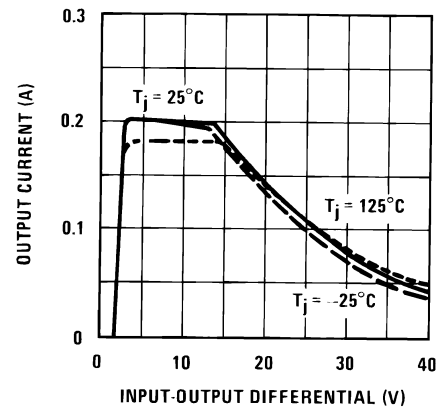
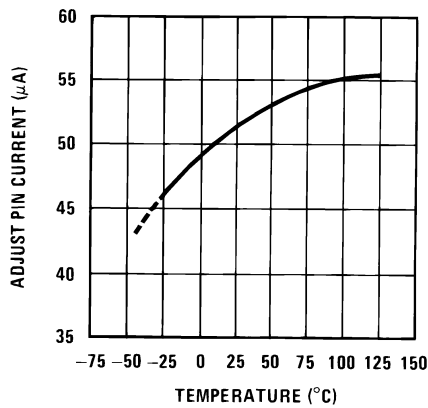
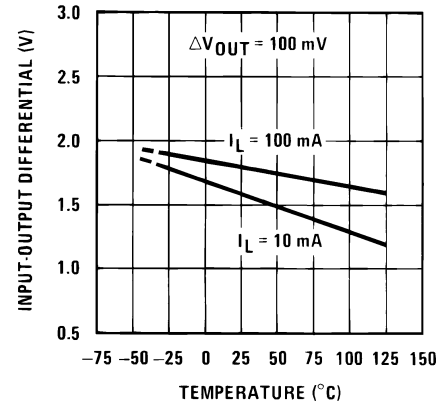
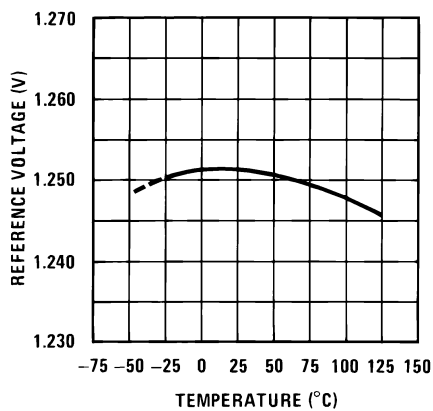
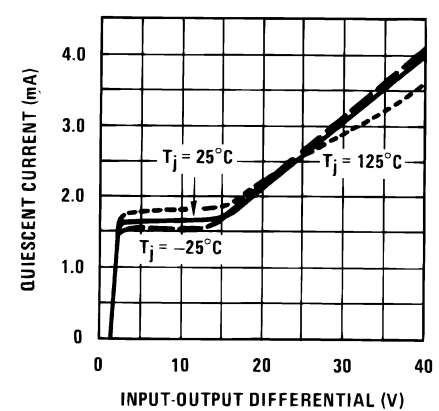
 (Output capacitor = 0  $\mu$ F unless otherwise noted.)

**Figure 1. Load Regulation**

**Figure 2. Current Limit**

**Figure 3. Adjustment Current**

**Figure 4. Dropout Voltage**

**Figure 5. Reference Voltage Temperature Stability**

**Figure 6. Minimum Operating Current**

Typical Characteristics (continued)

(Output capacitor = 0  $\mu$ F unless otherwise noted.)

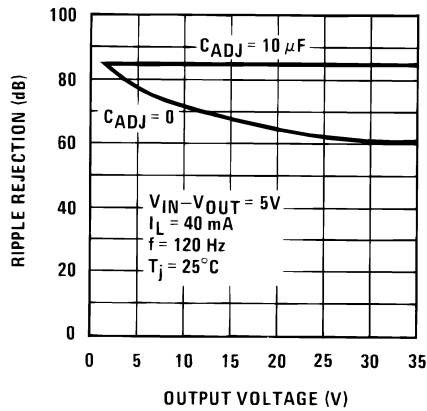

Figure 7. Ripple Rejection

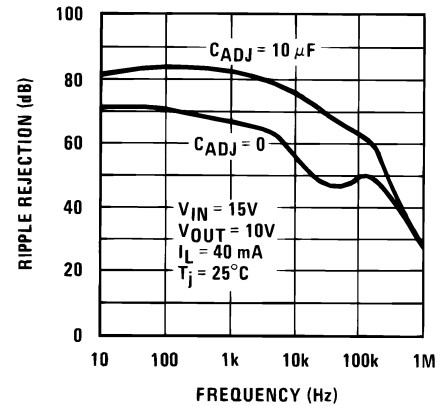

Figure 8. Ripple Rejection

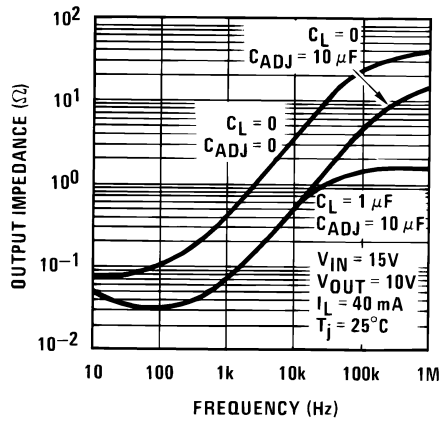

Figure 9. Output Impedance

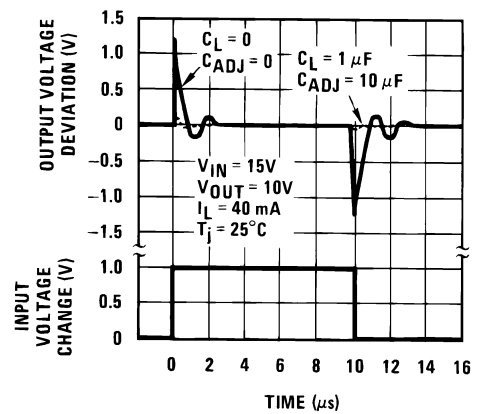

Figure 10. Line Transient Response

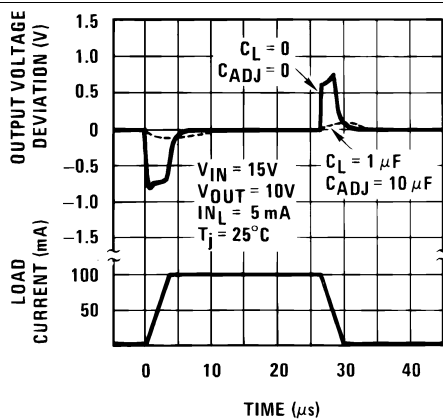

Figure 11. Load Transient Response

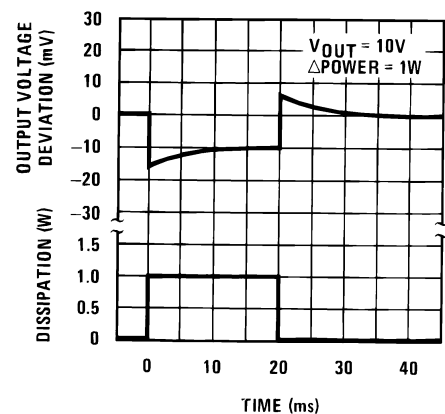

Figure 12. Thermal Regulation

## 7 Detailed Description

### 7.1 Overview

In operation, the LM317L-N develops a nominal 1.25-V reference voltage,  $V_{REF}$ , between the output and adjustment terminal. The reference voltage is impressed across program resistor  $R1$  and, because the voltage is constant, a constant current  $I_1$  then flows through the output set resistor  $R2$ , giving an output voltage of:

$$V_{OUT} = V_{REF} \left( 1 + \frac{R2}{R1} \right) + I_{ADJ}(R2) \quad (1)$$

Because the 100- $\mu$ A current from the adjustment terminal represents an error term, the LM317L-N was designed to minimize  $I_{ADJ}$  and make it very constant with line and load changes. To do this, all quiescent operating current is returned to the output establishing a minimum load current requirement. If there is insufficient load on the output, the output will rise.

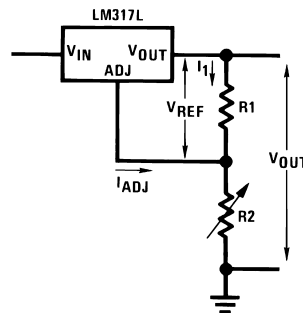

**Figure 13. Typical Application Circuit for Adjustable Regulator**



## 7.3 Feature Description

### 7.3.1 Load Regulation

The LM317L-N is capable of providing extremely good load regulation but a few precautions are needed to obtain maximum performance. The current set resistor connected between the adjustment terminal and the output terminal (usually 240  $\Omega$ ) must be tied directly to the output of the regulator rather than near the load. This eliminates line drops from appearing effectively in series with the reference and degrading regulation. For example, a 15-V regulator with 0.05- $\Omega$  resistance between the regulator and load will have a load regulation due to line resistance of 0.05  $\Omega \times I_L$ . If the set resistor is connected near the load the effective line resistance will be 0.05  $\Omega (1 + R_2/R_1)$  or in this case, 11.5 times worse.

Figure 14 shows the effect of resistance between the regulator and 240- $\Omega$  set resistor.

With the TO-92 package, it is easy to minimize the resistance from the case to the set resistor, by using two separate leads to the output pin. The ground of R2 can be returned near the ground of the load to provide remote ground-sensing and improve load regulation.

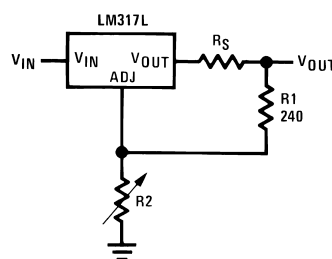

**Figure 14. Regulator With Line Resistance in Output Lead**

## 7.4 Device Functional Modes

### 7.4.1 External Capacitors

An input bypass capacitor is recommended in case the regulator is more than 6 inches away from the usual large filter capacitor. A 0.1- $\mu\text{F}$  disc or 1- $\mu\text{F}$  solid tantalum on the input is suitable input bypassing for almost all applications. The device is more sensitive to the absence of input bypassing when adjustment or output capacitors are used, but the above values will eliminate the possibility of problems.

The adjustment terminal can be bypassed to ground on the LM317L-N to improve ripple rejection and noise. This bypass capacitor prevents ripple and noise from being amplified as the output voltage is increased. With a 10- $\mu\text{F}$  bypass capacitor 80-dB ripple rejection is obtainable at any output level. Increases over 10- $\mu\text{F}$  do not appreciably improve the ripple rejection at frequencies above 120 Hz. If the bypass capacitor is used, it is sometimes necessary to include protection diodes to prevent the capacitor from discharging through internal low current paths and damaging the device.

In general, the best type of capacitors to use is solid tantalum. *Solid tantalum capacitors have low impedance even at high frequencies.* Depending upon capacitor construction, it takes about 25  $\mu\text{F}$  in aluminum electrolytic to equal 1- $\mu\text{F}$  solid tantalum at high frequencies. Ceramic capacitors are also good at high frequencies; but some types have a large decrease in capacitance at frequencies around 0.5 MHz. For this reason, a 0.01- $\mu\text{F}$  disc may seem to work better than a 0.1- $\mu\text{F}$  disc as a bypass.

Although the LM317L-N is stable with no output capacitors, like any feedback circuit, certain values of external capacitance can cause excessive ringing. This occurs with values between 500 pF and 5000 pF. A 1- $\mu\text{F}$  solid tantalum (or 25- $\mu\text{F}$  aluminum electrolytic) on the output swamps this effect and insures stability.

### 7.4.2 Protection Diodes

When external capacitors are used with *any* IC regulator it is sometimes necessary to add protection diodes to prevent the capacitors from discharging through low current points into the regulator. Most 10- $\mu\text{F}$  capacitors have low enough internal series resistance to deliver 20-A spikes when shorted. Although the surge is short, there is enough energy to damage parts of the IC.

## Device Functional Modes (continued)

When an output capacitor is connected to a regulator and the input is shorted, the output capacitor will discharge into the output of the regulator. The discharge current depends on the value of the capacitor, the output voltage of the regulator, and the rate of decrease of  $V_{IN}$ . In the LM317L-N, this discharge path is through a large junction that is able to sustain a 2-A surge with no problem. This is not true of other types of positive regulators. For output capacitors of 25  $\mu\text{F}$  or less, the ballast resistors and output structure of the LM317L-N limit the peak current to a low enough level so that there is no need to use a protection diode.

The bypass capacitor on the adjustment terminal can discharge through a low current junction. Discharge occurs when *either* the input or output is shorted. Internal to the LM317L-N is a 50- $\Omega$  resistor which limits the peak discharge current. No protection is needed for output voltages of 25 V or less and 10- $\mu\text{F}$  capacitance. [Figure 15](#) shows an LM317L-N with protection diodes included for use with outputs greater than 25 V and high values of output capacitance.

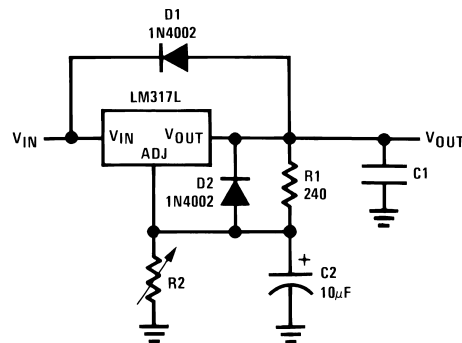

$$V_{OUT} = V_{REF} \left( 1 + \frac{R2}{R1} \right) + I_{ADJ}(R2)$$

D1 protects against C1

D2 protects against C2

**Figure 15. Regulator With Protection Diodes**

### 7.4.3 DSBGA Light Sensitivity

Exposing the LM317L-N DSBGA package to bright sunlight may cause the  $V_{REF}$  to drop. In a normal office environment of fluorescent lighting the output is not affected. The LM317 DSBGA does not sustain permanent damage from light exposure. Removing the light source causes  $V_{REF}$  of the LM317L-N to recover to the proper value.

## 8 Application and Implementation

### NOTE

Information in the following applications sections is not part of the TI component specification, and TI does not warrant its accuracy or completeness. TI's customers are responsible for determining suitability of components for their purposes. Customers should validate and test their design implementation to confirm system functionality.

### 8.1 Application Information

The LM317L-N is a versatile, high-performance, linear regulator with 1% output-voltage accuracy. An output capacitor can be added to further improve transient response, and the ADJ pin can be bypassed to achieve very high ripple-rejection ratios. Its functionality can be used in many different applications that require high performance regulation, such as battery chargers, constant-current regulators, and microprocessor supplies.

### 8.2 Typical Applications

#### 8.2.1 1.25-V to 25-V Adjustable Regulator

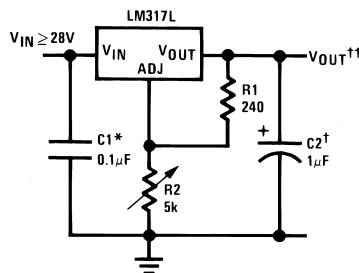

Full output current not available at high input-output voltages

†Optional—improves transient response

\*Needed if device is more than 6 inches from filter capacitors

$$\dagger\dagger V_{OUT} = 1.25V \left( 1 + \frac{R2}{R1} \right) + I_{ADJ} (R2)$$

**Figure 16. 1.25-V to 25-V Adjustable Regulator**

#### 8.2.1.1 Design Requirements

The device component count is very minimal, employing two resistors as part of a voltage-divider circuit and an output capacitor for load regulation. An input capacitor is needed if the device is more than 6 inches from filter capacitors. An optional bypass capacitor across R2 can also be used to improve PSRR.

#### 8.2.1.2 Detailed Design Procedure

The output voltage is set based on the selection of the two resistors, R1 and R2, as shown in [Figure 16](#). For details on capacitor selection, see [External Capacitors](#).

## Typical Applications (continued)

### 8.2.1.3 Application Curve

As shown in Figure 17,  $V_{OUT}$  rises with  $V_{IN}$  minus some dropout voltage. This dropout voltage during start-up will vary with  $R_{OUT}$ .

$$V_{OUT} = 5\text{ V}$$

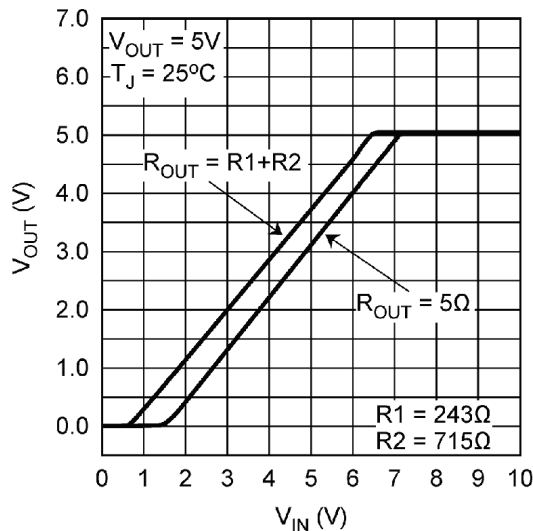
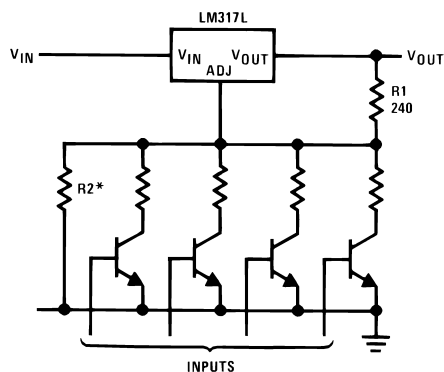

Figure 17.  $V_{OUT}$  vs  $V_{IN}$

### 8.2.2 Digitally-Selected Outputs

Figure 18 demonstrates a digitally-selectable output voltage. In its default state, all transistors are off and the output voltage is set based on  $R1$  and  $R2$ . By driving certain transistors, the associated resistor is connected in parallel to  $R2$ , modifying the output voltage of the regulator.



\*Sets maximum  $V_{OUT}$

Figure 18. Digitally-Selected Outputs

## Typical Applications (continued)

### 8.2.3 High Gain Amplifier

This application uses the LM395 Power Transistor to amplify the input voltage. The LM317L connected to R2 produces a constant current of  $1.2V/R2$  through the BJT. By altering the base current entering the LM395, the effective resistance can be changed resulting in an appropriate voltage fluctuation at the output.

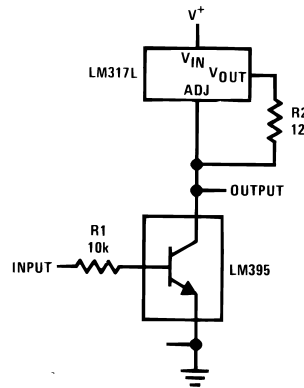
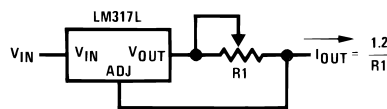

Figure 19. High Gain Amplifier

### 8.2.4 Adjustable Current Limiter

This application will limit the output current to the  $I_{OUT}$  in the diagram. The current limit is determined by adjusting the resistance between the  $V_{OUT}$  and  $V_{ADJ}$  pins. The 1.2-V reference voltage across R1 generates the maximum current.



$$12 \leq R1 \leq 240$$

Figure 20. Adjustable Current Limiter

### 8.2.5 Precision Current Limiter

This application will limit the output current to the  $I_{OUT}$  in the diagram. An initial reference current is generated based on the resistance between the  $V_{OUT}$  and  $V_{ADJ}$  pins. In the case of Figure 21, 1.25 V across 1 k $\Omega$  plus half of the 500- $\Omega$  resistor results in 1 mA of current, producing 1.5 V total across the two resistors in series. This voltage also appears across R1, making the maximum current the sum of the branch currents.

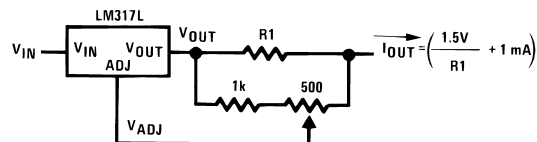

Figure 21. Precision Current Limiter

## Typical Applications (continued)

### 8.2.6 Slow Turnon 15-V Regulator

An application of LM317L-N includes a PNP transistor with a capacitor to implement slow turnon functionality (see Figure 22). As  $V_{IN}$  rises, the PNP sinks current from the ADJ rail. The output voltage at start-up is the addition of the 1.25-V reference plus the drop across the base to emitter. While this is happening, the capacitor begins to charge and eventually opens the PNP. At this point, the device functions normally, regulating the output at 15 V. A diode is placed between C1 and  $V_{OUT}$  to provide a path for the capacitor to discharge. Such controlled turnon is useful for limiting the in-rush current.

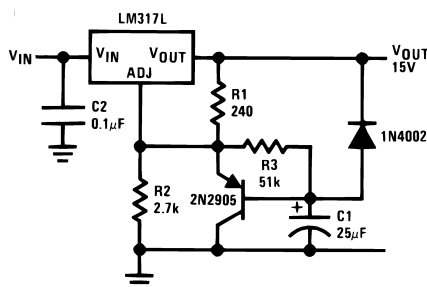
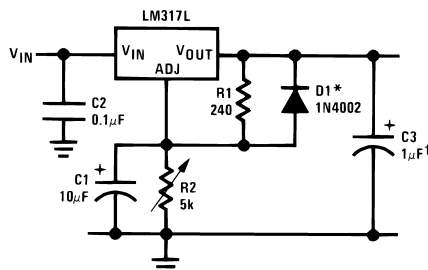

Figure 22. Slow Turnon 15-V Regulator

### 8.2.7 Adjustable Regulator With Improved Ripple Rejection

To improve ripple rejection, a capacitor is used to bypass the ADJ pin to GND (see Figure 23). This is used to smooth output ripple by cleaning the feedback path and stopping unnecessary noise from being fed back into the device, propagating the noise.



†Solid tantalum

\*Discharges C1 if output is shorted to ground

Figure 23. Adjustable Regulator With Improved Ripple Rejection

### 8.2.8 High Stability 10-V Regulator

This application will regulate to an output voltage of 10 V and will remain stable even with input voltage transients. The LM329 is a precision Zener reference diode that helps maintain stability.

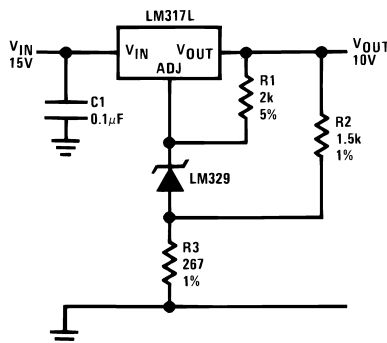
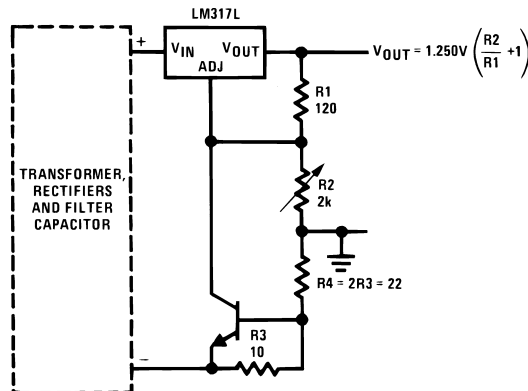

Figure 24. High Stability 10-V Regulator

Typical Applications (continued)

8.2.9 Adjustable Regulator With Current Limiter

This application regulates to an output voltage set by the ratio of R2 and R1 and limits the output current using R3 as shown in Figure 25.



Short circuit current is approximately 600 mV/R3, or 60 mA (compared to LM317L-NZ's 200-mA current limit).  
At 25-mA output only 3/4 V of drop occurs in R3 and R4.

Figure 25. Adjustable Regulator With Current Limiter

8.2.10 0-V to 30-V Regulator

This application regulates the output voltage from 0 V to 30 V using the resistor divider at the output. The adjustment pin reference voltage is 1.25 V so select the resistor divider that provides the needed output voltage.

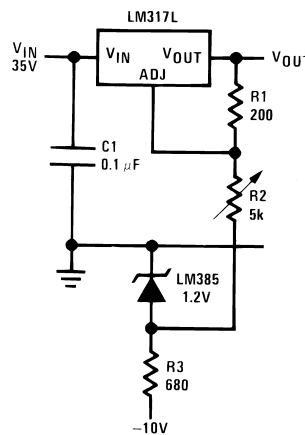

Full output current not available at high input-output voltages

Figure 26. 0-V to 30-V Regulator

## Typical Applications (continued)

### 8.2.11 Regulator With 15-mA Short-Circuit Current

This application regulates to a 10-V output with a 15-mA short-circuit current. The output voltage is set by the resistor divider at the output and the PNP is required to set the short-circuit current.

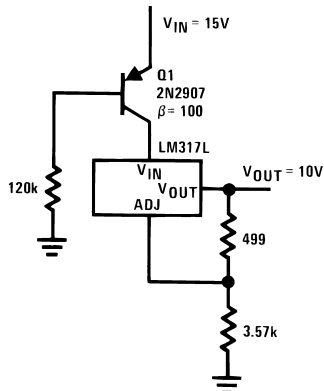

Figure 27. Regulator With 15-mA Short-Circuit Current

### 8.2.12 Power Follower

This application provides an output voltage that follows the input voltage while providing a current gain. The LM395 is a power transistor that operates as an emitter follower and provides a short-circuit current limit while the LM317 acts as a constant-current load.

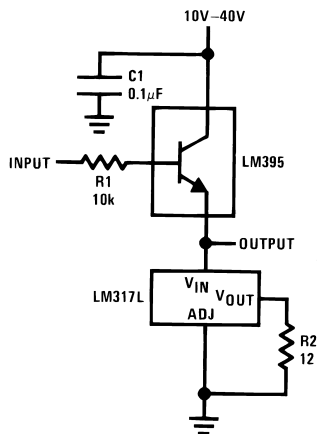
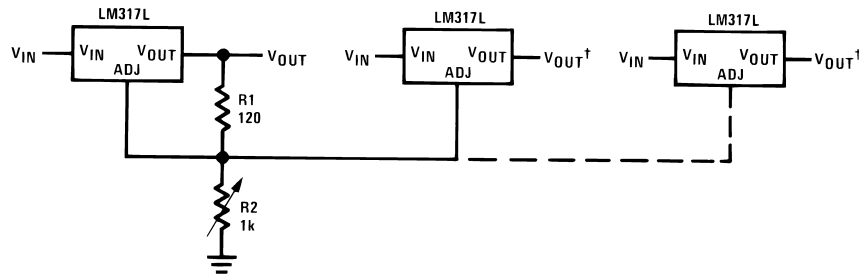

Figure 28. Power Follower

Typical Applications (continued)

8.2.13 Adjusting Multiple On-Card Regulators With Single Control

Figure 29 shows how multiple LM317L-N regulators can be controlled by setting one resistor. Because each device maintains the reference voltage of about 1.25 V between its  $V_{OUT}$  and ADJ pins, we can connect each ADJ rail to a single resistor, setting the same output voltage across all devices. This allows for independent outputs, each responding to its corresponding input only. Designers must also consider that by the nature of the circuit, changes to R1 and R2 will affect all regulators.



\*All outputs within  $\pm 100$  mV  
 †Minimum load –5 mA

Figure 29. Adjusting Multiple On-Card Regulators With Single Control\*

8.2.14 100-mA Current Regulator

This application regulates the output current to maximum of 100 mA as shown in Figure 30.

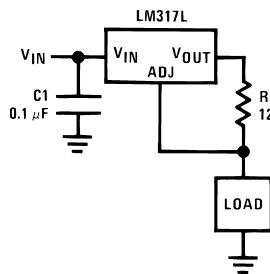
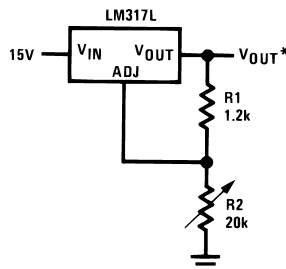

Figure 30. 100-mA Current Regulator

8.2.15 1.2-V to 12-V Regulator With Minimum Program Current

This application regulates the output voltage between 1.2 V and 12 V depending on the resistor divider at the output while allowing minimum programmable load current down to 2 mA as shown in Figure 31.



\*Minimum load current  $\approx 2$  mA

Figure 31. 1.2-V to 12-V Regulator With Minimum Program Current

## Typical Applications (continued)

### 8.2.16 50-mA Constant Current Battery Charger for Nickel-Cadmium Batteries

This application provides a 50-mA constant current at the output which can be used as a constant current battery charger for Nickel-Cadmium batteries. The resistor at the output sets the output current value.

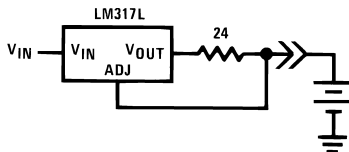
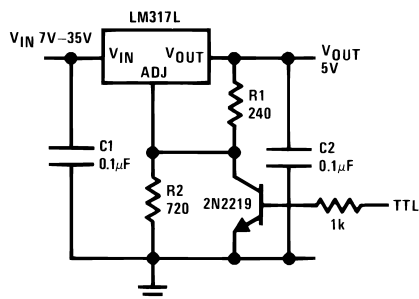

Figure 32. 50-mA Constant Current Battery Charger for Nickel-Cadmium Batteries

### 8.2.17 5-V Logic Regulator With Electronic Shutdown

Figure 33 shows a variation of the 5-V output regulator application uses the LM317L-N, along with an NPN transistor, to provide shutdown control. The NPN will either block or sink the current from the ADJ pin by responding to the TTL pin logic. When TTL is pulled high, the NPN is on and pulls the ADJ pin to GND, and the LM317L-N outputs about 1.25 V. When TTL is pulled low, the NPN is off and the regulator outputs according to the programmed adjustable voltage.



\*Minimum output  $\approx 1.2$  V

Figure 33. 5-V Logic Regulator With Electronic Shutdown\*

### 8.2.18 Current-Limited 6-V Charger

The current in a battery charger application is limited by switching between constant-current and constant-voltage states (see Figure 34). When the battery pulls low current, the drop across the 1- $\Omega$  resistor is not substantial and the NPN remains off. A constant voltage is seen across the battery, as regulated by the resistor divider. When current through the battery rises past peak current, the 1  $\Omega$  provides enough voltage to turn the transistor on, pulling ADJ close to ground. This results in limiting the maximum current to the battery.

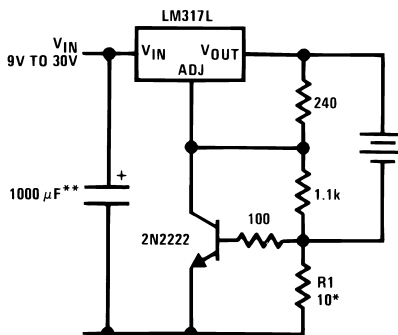

\*Sets peak current,  $I_{PEAK} = 0.6 \text{ V}/R1$

\*\*1000  $\mu\text{F}$  is recommended to filter out any input transients.

Figure 34. Current Limited 6-V Charger

Typical Applications (continued)

8.2.19 Short Circuit-Protected 80-V Supply

This application provides a 80-V output voltage from 0 mA to 20 mA as shown in Figure 35. The Triad provides an AC to DC conversion and the short-circuit protection is provided by the fuse. The output voltage can be adjusted by adjusting the resistor divider at the output.

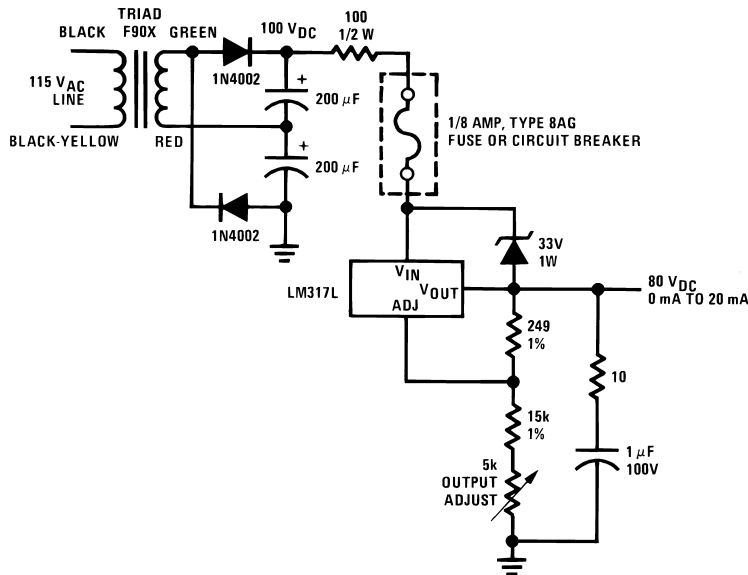
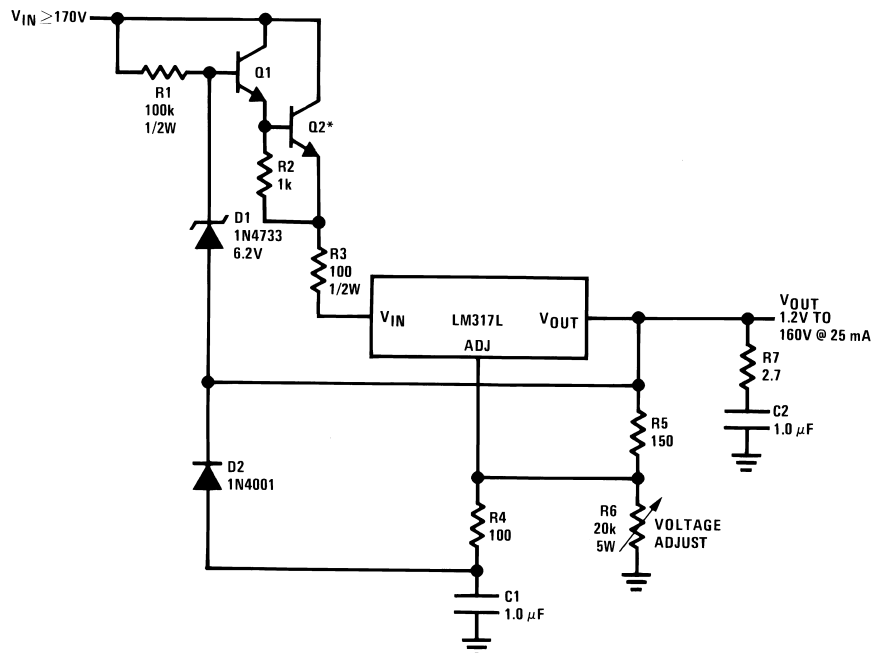

Figure 35. Short Circuit-Protected 80-V Supply

## Typical Applications (continued)

### 8.2.20 Basic High-Voltage Regulator

This application regulates the output voltage from 1.2 V to 160 V at 25 mA as shown in Figure 36. The output voltage is set by the resistor divider at the output. The Darlington pair transistor configuration provides a current gain from the input source to the LM317.



Q1, Q2: NSD134 or similar  
C1, C2: 1  $\mu$ F, 200-V mylar\*\*  
\*Heat sink

Figure 36. Basic High-Voltage Regulator

## Typical Applications (continued)

### 8.2.21 Precision High-Voltage Regulator

This application regulates the output voltage from 8 V to 160 V at 25 mA as shown in Figure 37. The Zener diode connected from the adjust pin to  $V_{OUT}$  provides better precision than the basic high-voltage regulator.

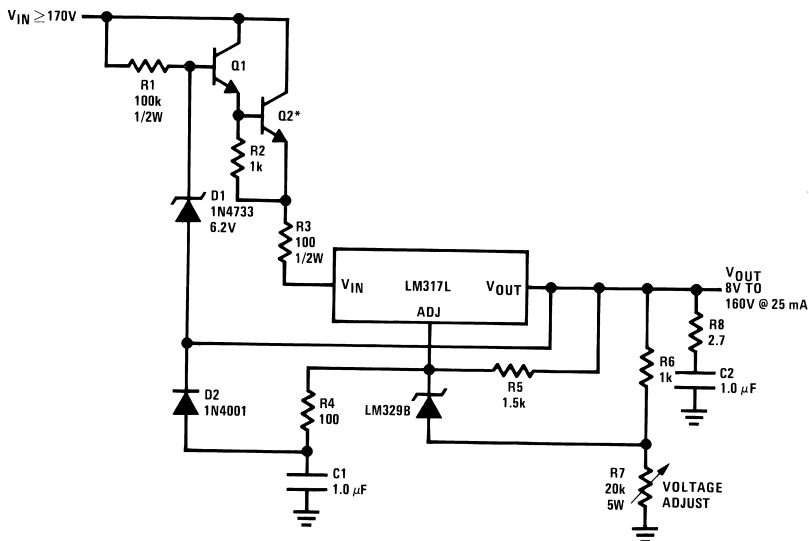

Q1, Q2: NSD134 or similar  
 C1, C2: 1  $\mu$ F, 200-V mylar\*\*  
 \*Heat sink  
 \*\*Mylar is a registered trademark of DuPont Co.

Figure 37. Precision High-Voltage Regulator

### 8.2.22 Tracking Regulator

This application regulates to an output voltage set by the output resistor divider and also uses the LM301A operational amplifier to provide a negative voltage that tracks the output voltage.

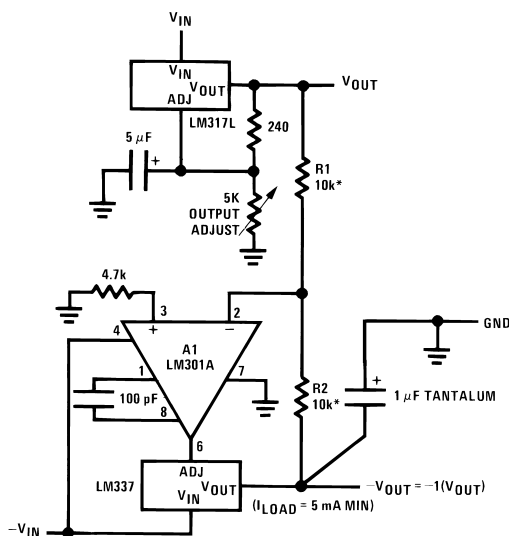

A1 = LM301A, LM307, or LF13741 only  
 R1, R2 = matched resistors with good TC tracking

Figure 38. Tracking Regulator

## Typical Applications (continued)

### 8.2.23 Regulator With Trimmable Output Voltage

This application provides an output voltage set by the output resistor divider that can be finely tuned to  $\pm 1\%$  by removing output resistors. See the trim procedure in Figure 39.

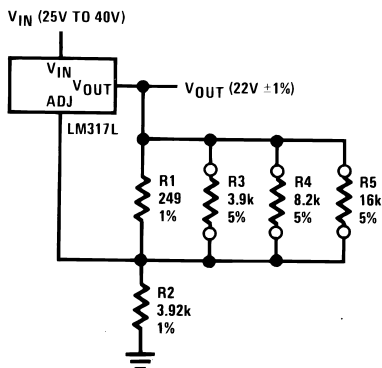

#### Trim Procedure:

- If  $V_{OUT}$  is 23.08 V or higher, cut out R3 (if lower, don't cut it out).
- Then if  $V_{OUT}$  is 22.47 V or higher, cut out R4 (if lower, don't).
- Then if  $V_{OUT}$  is 22.16 V or higher, cut out R5 (if lower, don't).

This will trim the output to well within  $\pm 1\%$  of 22.00  $V_{DC}$ , without any of the expense or uncertainty of a trim pot (see LB-46). This technique can be used at any output voltage level.

Figure 39. Regulator With Trimmable Output Voltage

### 8.2.24 Precision Reference With Short-Circuit Proof Output

This application provides a precise output voltage with short-circuit protection. The precision results from using the LM308A operational amplifier connected between the adjust pin and output voltage pin as a comparator with the LM299AH precision reference.

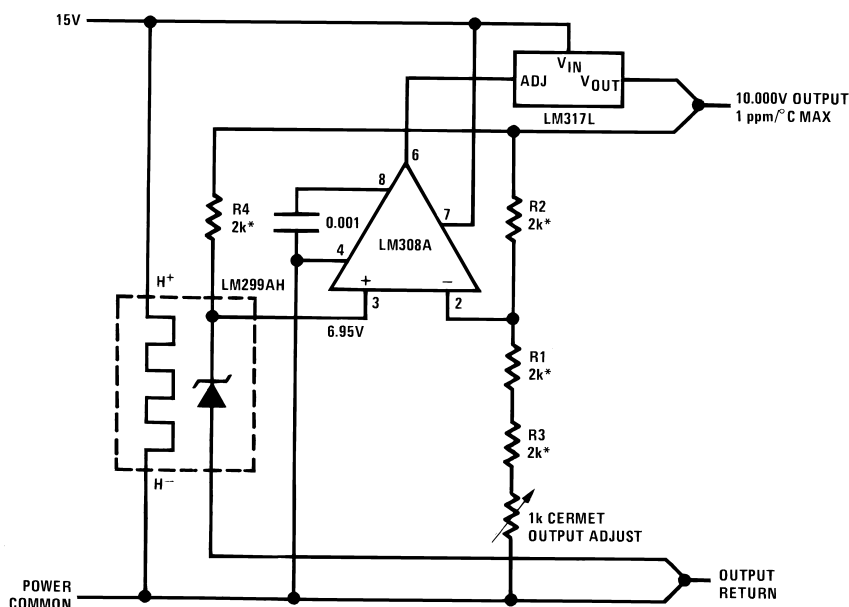

\*R1–R4 from thin-film network,  
Beckman 694-3-R2K-D or similar

Figure 40. Precision Reference With Short-Circuit Proof Output

Typical Applications (continued)

8.2.25 Fully-Protected (Bulletproof) Lamp Driver

This application drives a lamp using a programmable gain instrumentation amplifier at the output.

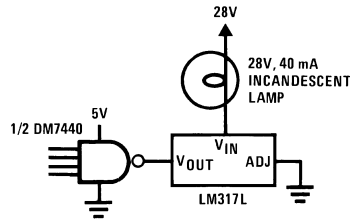
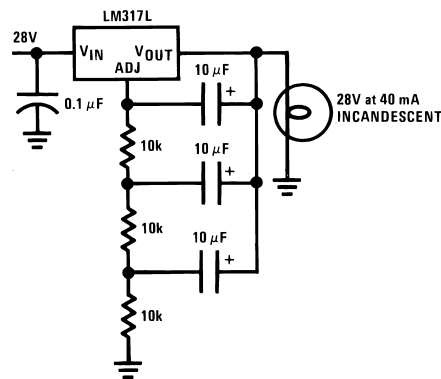

Figure 41. Fully-Protected (Bulletproof) Lamp Driver

8.2.26 Lamp Flasher

This application uses a combination of capacitors and resistors connected between the output voltage pin and the adjust pin to cause the lamp connected at the output voltage pin to flash.



Output rate—4 flashes per second at 10% duty cycle

Figure 42. Lamp Flasher

## 9 Power Supply Recommendations

The input supply to the LM317L-N must be kept at a voltage level lower than the maximum input-to-output differential voltage of 40 V. When possible, the minimum dropout voltage must also be met with extra headroom to keep the LM317L-N in regulation. TI recommends using an input capacitor, especially when the input pin is located more than 6 inches away from the power supply source. For more information regarding capacitor selection, see [External Capacitors](#).

## 10 Layout

### 10.1 Layout Guidelines

Some layout guidelines should be followed to ensure proper regulation of the output voltage with minimum noise. Traces carrying the load current must be wide to reduce the amount of parasitic trace inductance and the feedback loop from  $V_{OUT}$  to ADJ should be kept as short as possible. To improve PSRR, a bypass capacitor can be placed at the ADJ pin and must be located as close as possible to the IC. In cases when  $V_{IN}$  shorts to ground, an external diode should be placed from  $V_{OUT}$  to  $V_{IN}$  to divert the surge current from the output capacitor and protect the IC. Similarly, in cases when a large bypass capacitor is placed at the ADJ pin and  $V_{OUT}$  shorts to ground, an external diode should be placed from ADJ to  $V_{OUT}$  to provide a path for the bypass capacitor to discharge. These diodes must be placed close to the corresponding IC pins to increase their effectiveness.

### 10.2 Layout Examples

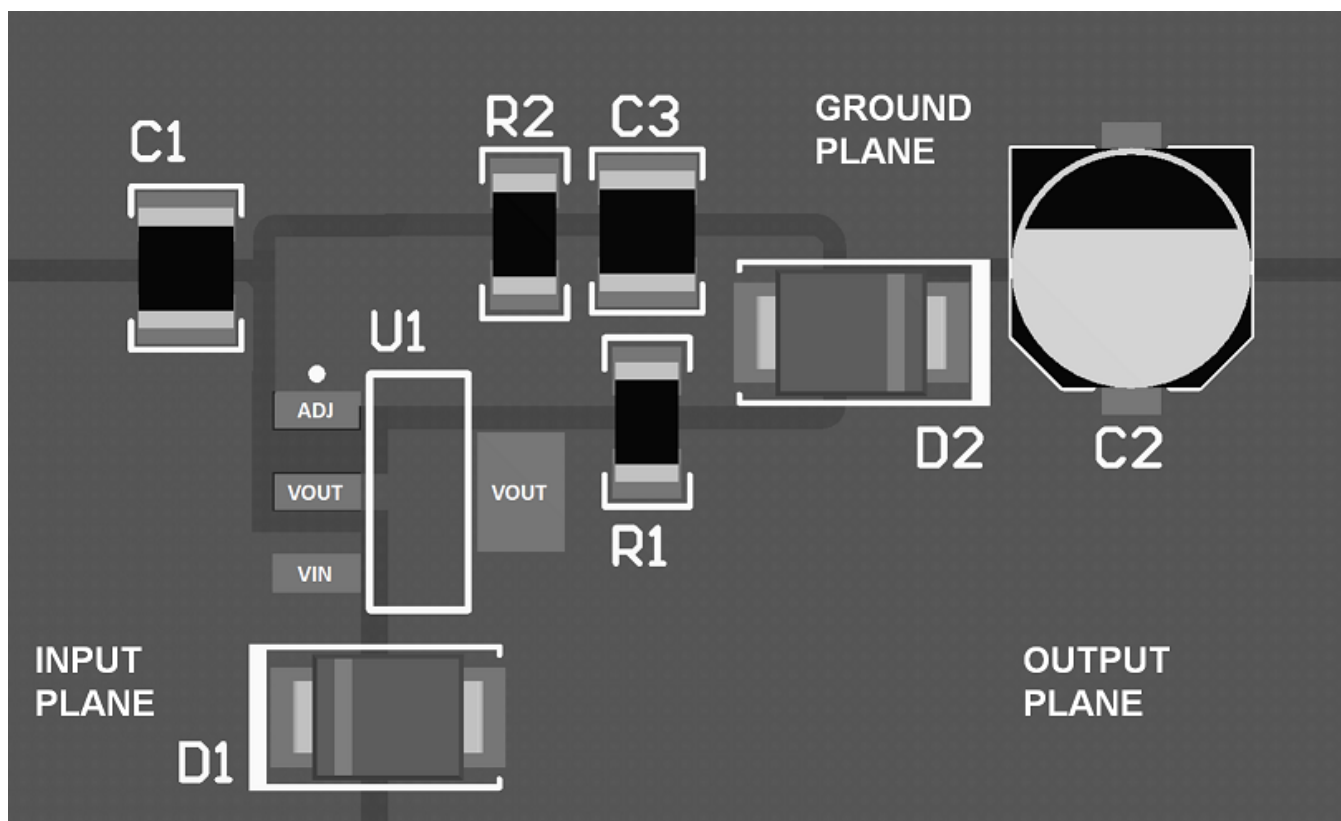
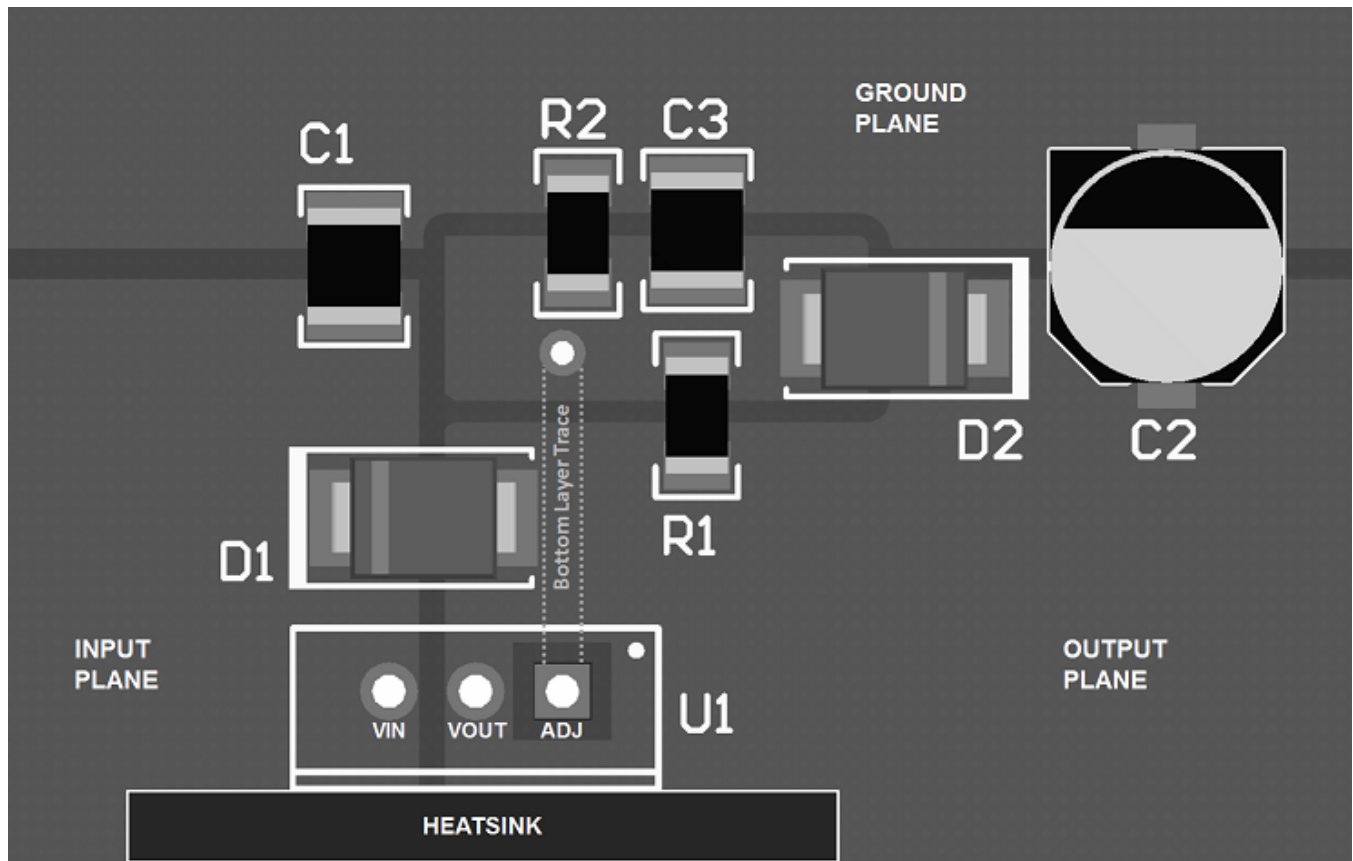

Figure 43. Layout Example (SOT-223)

**Layout Examples (continued)**

**Figure 44. Layout Example (TO-220)**
**10.3 Thermal Considerations**

When power is dissipated in an IC, a temperature gradient occurs across the IC chip affecting the individual IC circuit components. With an IC regulator, this gradient can be especially severe since power dissipation is large. Thermal regulation is the effect of these temperature gradients on output voltage (in percentage output change) per watt of power change in a specified time. Thermal regulation error is independent of electrical regulation or temperature coefficient, and occurs within 5 ms to 50 ms after a change in power dissipation. Thermal regulation depends on IC layout as well as electrical design. The thermal regulation of a voltage regulator is defined as the percentage change of  $V_{OUT}$ , per watt, within the first 10 ms after a step of power is applied. The LM317L-N specification is 0.2%/W, maximum.

In [Figure 12](#), a typical output of the LM317L-N changes only 7 mV (or 0.07% of  $V_{OUT} = -10$  V) when a 1-W pulse is applied for 10 ms. This performance is thus well inside the specification limit of  $0.2\%/W \times 1$  W = 0.2% maximum. When the 1-W pulse is ended, the thermal regulation again shows a 7-mV change as the gradients across the LM317L-N chip die out.

---

**NOTE**

The load regulation error of about 14 mV (0.14%) is additional to the thermal regulation error.

---

## 11 Device and Documentation Support

### 11.1 Documentation Support

#### 11.1.1 Related Documentation

For related documentation, see the following:

*AN-1112 DSBGA Wafer Level Chip Scale Package* ([SNVA009](#))

### 11.2 Community Resources

The following links connect to TI community resources. Linked contents are provided "AS IS" by the respective contributors. They do not constitute TI specifications and do not necessarily reflect TI's views; see TI's [Terms of Use](#).

**TI E2E™ Online Community** *TI's Engineer-to-Engineer (E2E) Community*. Created to foster collaboration among engineers. At [e2e.ti.com](#), you can ask questions, share knowledge, explore ideas and help solve problems with fellow engineers.

**Design Support** *TI's Design Support* Quickly find helpful E2E forums along with design support tools and contact information for technical support.

### 11.3 Trademarks

E2E is a trademark of Texas Instruments.  
All other trademarks are the property of their respective owners.

### 11.4 Electrostatic Discharge Caution



These devices have limited built-in ESD protection. The leads should be shorted together or the device placed in conductive foam during storage or handling to prevent electrostatic damage to the MOS gates.

### 11.5 Glossary

[SLYZ022](#) — *TI Glossary*.

This glossary lists and explains terms, acronyms, and definitions.

## 12 Mechanical, Packaging, and Orderable Information

The following pages include mechanical, packaging, and orderable information. This information is the most current data available for the designated devices. This data is subject to change without notice and revision of this document. For browser-based versions of this data sheet, refer to the left-hand navigation.

**PACKAGING INFORMATION**

Orderable Device	Status (1)	Package Type	Package Drawing	Pins	Package Qty	Eco Plan (2)	Lead/Ball Finish (6)	MSL Peak Temp (3)	Op Temp (°C)	Device Marking (4/5)	Samples
LM317LITP/NOPB	ACTIVE	DSBGA	YPB	6	250	Green (RoHS & no Sb/Br)	SNAGCU	Level-1-260C-UNLIM	-40 to 125	P 1	<a href="#">Samples</a>
LM317LITPX/NOPB	ACTIVE	DSBGA	YPB	6	3000	Green (RoHS & no Sb/Br)	SNAGCU	Level-1-260C-UNLIM	-40 to 125	P 1	<a href="#">Samples</a>
LM317LM/NOPB	ACTIVE	SOIC	D	8	95	Green (RoHS & no Sb/Br)	CU SN   Call TI	Level-1-260C-UNLIM	-40 to 125	LM317 LM	<a href="#">Samples</a>
LM317LMX	NRND	SOIC	D	8	2500	TBD	Call TI	Call TI	-40 to 125	LM317 LM	
LM317LMX/NOPB	ACTIVE	SOIC	D	8	2500	Green (RoHS & no Sb/Br)	CU SN   Call TI	Level-1-260C-UNLIM	-40 to 125	LM317 LM	<a href="#">Samples</a>
LM317LZ/LFT1	ACTIVE	TO-92	LP	3	2000	Green (RoHS & no Sb/Br)	CU SN	N / A for Pkg Type		LM317 LZ	<a href="#">Samples</a>
LM317LZ/LFT2	ACTIVE	TO-92	LP	3	2000	Green (RoHS & no Sb/Br)	CU SN	N / A for Pkg Type		LM317 LZ	<a href="#">Samples</a>
LM317LZ/LFT3	ACTIVE	TO-92	LP	3	2000	Green (RoHS & no Sb/Br)	CU SN	N / A for Pkg Type		LM317 LZ	<a href="#">Samples</a>
LM317LZ/LFT4	ACTIVE	TO-92	LP	3	2000	Green (RoHS & no Sb/Br)	CU SN	N / A for Pkg Type		LM317 LZ	<a href="#">Samples</a>
LM317LZ/LFT7	ACTIVE	TO-92	LP	3	2000	Green (RoHS & no Sb/Br)	CU SN	N / A for Pkg Type		LM317 LZ	<a href="#">Samples</a>
LM317LZ/NOPB	ACTIVE	TO-92	LP	3	1800	Green (RoHS & no Sb/Br)	CU SN	N / A for Pkg Type	-40 to 125	LM317 LZ	<a href="#">Samples</a>

(1) The marketing status values are defined as follows:

**ACTIVE:** Product device recommended for new designs.

**LIFEBUY:** TI has announced that the device will be discontinued, and a lifetime-buy period is in effect.

**NRND:** Not recommended for new designs. Device is in production to support existing customers, but TI does not recommend using this part in a new design.

**PREVIEW:** Device has been announced but is not in production. Samples may or may not be available.

**OBSELETE:** TI has discontinued the production of the device.

(2) **RoHS:** TI defines "RoHS" to mean semiconductor products that are compliant with the current EU RoHS requirements for all 10 RoHS substances, including the requirement that RoHS substance do not exceed 0.1% by weight in homogeneous materials. Where designed to be soldered at high temperatures, "RoHS" products are suitable for use in specified lead-free processes. TI may reference these types of products as "Pb-Free".

**RoHS Exempt:** TI defines "RoHS Exempt" to mean products that contain lead but are compliant with EU RoHS pursuant to a specific EU RoHS exemption.

**Green:** TI defines "Green" to mean the content of Chlorine (Cl) and Bromine (Br) based flame retardants meet JS709B low halogen requirements of <=1000ppm threshold. Antimony trioxide based flame retardants must also meet the <=1000ppm threshold requirement.

- (3) MSL, Peak Temp. - The Moisture Sensitivity Level rating according to the JEDEC industry standard classifications, and peak solder temperature.
- (4) There may be additional marking, which relates to the logo, the lot trace code information, or the environmental category on the device.
- (5) Multiple Device Markings will be inside parentheses. Only one Device Marking contained in parentheses and separated by a "~" will appear on a device. If a line is indented then it is a continuation of the previous line and the two combined represent the entire Device Marking for that device.
- (6) Lead/Ball Finish - Orderable Devices may have multiple material finish options. Finish options are separated by a vertical ruled line. Lead/Ball Finish values may wrap to two lines if the finish value exceeds the maximum column width.

**Important Information and Disclaimer:**The information provided on this page represents TI's knowledge and belief as of the date that it is provided. TI bases its knowledge and belief on information provided by third parties, and makes no representation or warranty as to the accuracy of such information. Efforts are underway to better integrate information from third parties. TI has taken and continues to take reasonable steps to provide representative and accurate information but may not have conducted destructive testing or chemical analysis on incoming materials and chemicals. TI and TI suppliers consider certain information to be proprietary, and thus CAS numbers and other limited information may not be available for release.

In no event shall TI's liability arising out of such information exceed the total purchase price of the TI part(s) at issue in this document sold by TI to Customer on an annual basis.

**TAPE AND REEL INFORMATION**

**QUADRANT ASSIGNMENTS FOR PIN 1 ORIENTATION IN TAPE**

\*All dimensions are nominal

Device	Package Type	Package Drawing	Pins	SPQ	Reel Diameter (mm)	Reel Width W1 (mm)	A0 (mm)	B0 (mm)	K0 (mm)	P1 (mm)	W (mm)	Pin1 Quadrant
LM317LITP/NOPB	DSBGA	YPB	6	250	178.0	8.4	1.09	1.75	0.66	4.0	8.0	Q1
LM317LITPX/NOPB	DSBGA	YPB	6	3000	178.0	8.4	1.09	1.75	0.66	4.0	8.0	Q1
LM317LMX	SOIC	D	8	2500	330.0	12.4	6.5	5.4	2.0	8.0	12.0	Q1
LM317LMX/NOPB	SOIC	D	8	2500	330.0	12.4	6.5	5.4	2.0	8.0	12.0	Q1

**TAPE AND REEL BOX DIMENSIONS**

\*All dimensions are nominal

Device	Package Type	Package Drawing	Pins	SPQ	Length (mm)	Width (mm)	Height (mm)
LM317LITP/NOPB	DSBGA	YPB	6	250	210.0	185.0	35.0
LM317LITPX/NOPB	DSBGA	YPB	6	3000	210.0	185.0	35.0
LM317LMX	SOIC	D	8	2500	367.0	367.0	35.0
LM317LMX/NOPB	SOIC	D	8	2500	367.0	367.0	35.0

## IMPORTANT NOTICE AND DISCLAIMER

TI PROVIDES TECHNICAL AND RELIABILITY DATA (INCLUDING DATASHEETS), DESIGN RESOURCES (INCLUDING REFERENCE DESIGNS), APPLICATION OR OTHER DESIGN ADVICE, WEB TOOLS, SAFETY INFORMATION, AND OTHER RESOURCES "AS IS" AND WITH ALL FAULTS, AND DISCLAIMS ALL WARRANTIES, EXPRESS AND IMPLIED, INCLUDING WITHOUT LIMITATION ANY IMPLIED WARRANTIES OF MERCHANTABILITY, FITNESS FOR A PARTICULAR PURPOSE OR NON-INFRINGEMENT OF THIRD PARTY INTELLECTUAL PROPERTY RIGHTS.

These resources are intended for skilled developers designing with TI products. You are solely responsible for (1) selecting the appropriate TI products for your application, (2) designing, validating and testing your application, and (3) ensuring your application meets applicable standards, and any other safety, security, or other requirements. These resources are subject to change without notice. TI grants you permission to use these resources only for development of an application that uses the TI products described in the resource. Other reproduction and display of these resources is prohibited. No license is granted to any other TI intellectual property right or to any third party intellectual property right. TI disclaims responsibility for, and you will fully indemnify TI and its representatives against, any claims, damages, costs, losses, and liabilities arising out of your use of these resources.

TI's products are provided subject to TI's Terms of Sale ([www.ti.com/legal/termsofsale.html](http://www.ti.com/legal/termsofsale.html)) or other applicable terms available either on [ti.com](http://ti.com) or provided in conjunction with such TI products. TI's provision of these resources does not expand or otherwise alter TI's applicable warranties or warranty disclaimers for TI products.

Mailing Address: Texas Instruments, Post Office Box 655303, Dallas, Texas 75265  
Copyright © 2019, Texas Instruments Incorporated

## Looking for pricing, stock, or lifecycle information?

Click below to explore more details on WIN SOURCE:

 [View LM317LM/NOPB on WIN SOURCE](#)

 [Texas Instruments](#) Information

## Optimize Your Supply Chain with WIN SOURCE Solutions

-  Global Sourcing Solution
-  Obsolete Management
-  Cost Control Management
-  Shortage Management
-  Alternative Solution
-  Excess Inventory Management