



THE DATASHEET OF LM3206TLX



LM3206

650mA Miniature, Step-Down DC-DC Converter for Portable Applications

General Description

The LM3206 is a DC-DC converter optimized for powering portable applications from a single Lithium-Ion cell, however they may be used in many other applications. It steps down an input voltage from 3.25V to 5.5V to a fixed output voltage of 3.09V.

The LM3206 offers superior performance for mobile phones and other applications requiring low dropout voltage. Fixed-frequency PWM operation minimizes RF interference. The Shutdown function turns the device off and reduces battery consumption to 0.01 μA (typ.).

The LM3206 is available in an 8-pin lead free micro SMD package. A high switching frequency (2 MHz) allows use of tiny surface-mount components. Only three small external surface-mount components, an inductor and two ceramic capacitors are required.

Features

- 2 MHz (typ.) PWM Switching Frequency
- Operates from a single Li-Ion cell
- Fixed Output Voltage (3.09V)
- 650mA Maximum load capability
- High Efficiency (96% Typ at 3.6V_{IN}, 3.09V_{OUT} at 400mA) from internal synchronous rectification
- 8-pin micro SMD Package
- Current Overload Protection
- Thermal Overload Protection
- Soft Start function
- Low Dropout Voltage (140 m Ω Typ PFET)

Applications

- Cellular Phones
- Hand-Held Radios
- RF PC Cards
- Battery Powered RF Devices
- RFIC Chipsets

Typical Application

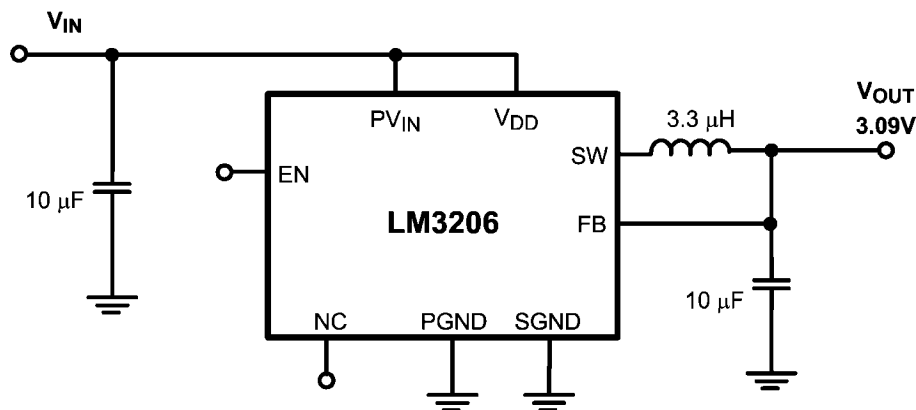

20198901

FIGURE 1. LM3206 Typical Application

Connection Diagrams

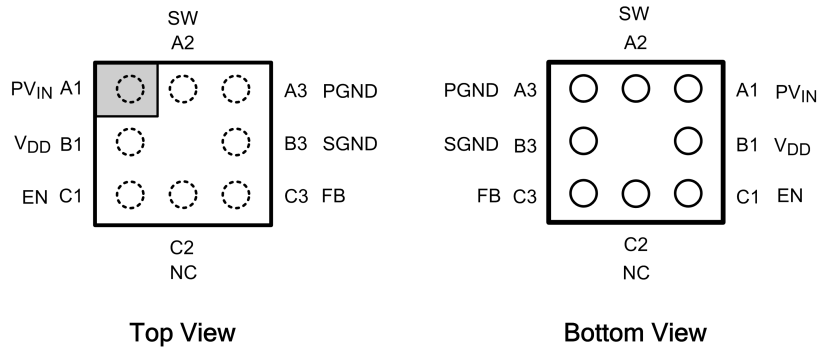

20198999

**8-Bump Thin Micro SMD Package, Large Bump
NS Package Number TLA08HPA**

Order Information

Order Number	Package Marking (Note)	Supplied As
LM3206TL	XTS/29	250 units, Tape-and-Reel
LM3206TLX	XTS/29	3000 units, Tape-and-Reel

Note: The actual physical placement of the package marking will vary from part to part. The package marking "X" designates the date code. "T" is a NSC internal code for die traceability. "S" designates the device type as switcher device. Both will vary considerably. "29" identifies the device (part number, option, etc.). Call National Semiconductor for detailed ordering information.

Pin Descriptions

Pin #	Name	Description
A1	PV _{IN}	Power Supply Voltage Input to the internal PFET switch.
B1	V _{DD}	Analog Supply Input.
C1	EN	Enable Input. Set this digital input high for normal operation. For shutdown, set low.
C2	NC	May be connected to V _{DD} , SGND or floating.
C3	FB	Feedback Analog Input. Connect to the output at the output filter capacitor.
B3	SGND	Analog and Control Ground
A3	PGND	Power Ground
A2	SW	Switch node connection to the internal PFET switch and NFET synchronous rectifier. Connect to an inductor with a saturation current rating that exceeds the maximum Switch Peak Current Limit specification of the LM3206.

Absolute Maximum Ratings (Notes 1, 2)

If Military/Aerospace specified devices are required, please contact the National Semiconductor Sales Office/ Distributors for availability and specifications.

V_{DD}, PV_{IN} to SGND	-0.2V to +6.0V
PGND to SGND	-0.2V to +0.2V
EN, FB, NC	(SGND -0.2V) to ($V_{DD} + 0.2V$) w/6.0V max
SW	(PGND -0.2V) to ($PV_{IN} + 0.2V$) w/6.0V max
PV_{IN} to V_{DD}	-0.2V to +0.2V
Continuous Power Dissipation (Note 3)	Internally Limited
Junction Temperature (T_{J-MAX})	+150°C
Storage Temperature Range	-65°C to +150°C

Maximum Lead Temperature (Soldering, 10 sec)	+260°C
ESD Rating (Notes 4, 13)	2 kV
Human Body Model:	200V
Machine Model:	

Operating Ratings (Notes 1, 2)

Input Voltage Range	2.7V to 5.5V
Recommended Load Current	0mA to 650mA
Junction Temperature (T_J) Range	-30°C to +125°C
Ambient Temperature (T_A) Range (Note 5)	-30°C to +85°C

Thermal Properties

Junction-to-Ambient Thermal Resistance (θ_{JA}), TLA08 Package (Note 6)	100°C/W
--	---------

Electrical Characteristics (Notes 2, 7, 8) Limits in standard typeface are for $T_A = T_J = 25^\circ\text{C}$. Limits in **boldface** type apply over the full operating ambient temperature range ($-30^\circ\text{C} \leq T_A = T_J \leq +85^\circ\text{C}$). Unless otherwise noted, all specifications apply to LM3206 with: $PV_{IN} = V_{DD} = EN = 3.6V$.

Symbol	Parameter	Conditions	Min	Typ	Max	Units
V_{FB}	Feedback Voltage	$P_{VIN} = 3.6V$	3.028	3.09	3.15	V
I_{SHDN}	Shutdown supply current	EN = SW = 0V, (Note 9)		0.01	2	μA
I_Q	DC bias current into V_{DD}	FB = 0V, No Switching (Note 10)		1	1.4	mA
$R_{DSON(P)}$	Pin-pin resistance for PFET	$I_{SW} = 200\text{mA}$		140	200 230	$\text{m}\Omega$
$R_{DSON(N)}$	Pin-pin resistance for NFET	$I_{SW} = -200\text{mA}$		300	415 485	$\text{m}\Omega$
$I_{LIM,PFET}$	Switch peak current limit	(Note 11)	935	1100	1200	mA
F_{OSC}	Internal oscillator frequency		1.7	2	2.3	MHz
$V_{IH,EN}$	Logic high input threshold		1.2			V
$V_{IL,EN}$	Logic low input threshold				0.5	V
$I_{PIN,ENABLE}$	Pin pull down current			5	10	μA

System Characteristics

The following spec table entries are guaranteed by design providing the component values in the typical application circuit are used. **These parameters are not guaranteed by production testing.** Min and Max limits apply over the full operating ambient temperature range ($-30^{\circ}\text{C} \leq T_A \leq 85^{\circ}\text{C}$) and over the V_{IN} range = 3.25V to 5.5V unless otherwise specified, Typical values are at $T_A = 25^{\circ}\text{C}$, $PV_{IN} = V_{DD} = EN = 3.6\text{V}$ unless otherwise specified, $L = 3.3\mu\text{H}$ (Note 14), DCR of $L \leq 100\text{m}\Omega$ (FDK, MIPSA2520D3R3), $C_{IN} = 10\mu\text{F}$, 0603, 6.3V (TDK, 1608X5R0J106M), $C_{OUT} = 10\mu\text{F}$, 0603, 6.3V(TDK, 1608X5R0J106M).

Symbol	Parameter	Conditions	Min	Typ	Max	Units
T_{ON}	Turn on time (time for output to reach 3.09V from Enable low to high transition)	$EN = \text{Low to High}$, $V_{IN} = 4.2\text{V}$, $V_O = 3.09\text{V}$, $C_{OUT} = 10\mu\text{F}$, $I_{OUT} \leq 1\text{mA}$		210	350	μs
η	Efficiency ($L = 3.3\mu\text{H}$, $\text{DCR} \leq 100\text{m}\Omega$)	$V_{IN} = 3.6\text{V}$, $V_{OUT} = 3.09\text{V}$, $I_{OUT} = 400\text{mA}$		96		%
V_{OUT_ripple}	Ripple voltage, PWM mode	$V_{IN} = 4.2\text{V}$, $V_{OUT} = 3.09\text{V}$, $I_{OUT} = 10\text{mA}$ to 400mA (Note 12)		5		mVp-p
Line_tr	Line transient response	$V_{IN} = 600\text{mV}$ perturbation, over V_{in} range 3.4V to 5.5V $T_{RISE} = T_{FALL} = 10\mu\text{s}$, $V_{OUT} = 3.09\text{V}$, $I_{OUT} =$ 100mA		50		mVpk
Load_tr	Load transient response	$V_{IN} = 4.2\text{V}$, $V_{OUT} = 3.09\text{V}$, transients up to 100mA, $T_{RISE} = T_{FALL} = 10\mu\text{s}$		50		mVpk

Note 1: Absolute Maximum Ratings indicate limits beyond which damage to the component may occur. Operating Ratings are conditions under which operation of the device is guaranteed. Operating Ratings do not imply guaranteed performance limits. For guaranteed performance limits and associated test conditions, see the Electrical Characteristics tables.

Note 2: All voltages are with respect to the potential at the GND pins. The LM3206 is designed for mobile phone applications where turn-on after power-up is controlled by the system controller and where requirements for a small package size overrule increased die size for internal Under Voltage Lock-Out (UVLO) circuitry. Thus, it should be kept in shutdown by holding the EN pin low until the input voltage exceeds 3.25V.

Note 3: Internal thermal shutdown circuitry protects the device from permanent damage. Thermal shutdown engages at $T_J = 150^{\circ}\text{C}$ (typ.) and disengages at $T_J = 130^{\circ}\text{C}$ (typ.).

Note 4: The Human body model is a 100pF capacitor discharged through a 1.5k Ω resistor into each pin. (MIL-STD-883 3015.7) The machine model is a 200pF capacitor discharged directly into each pin.

Note 5: In applications where high power dissipation and/or poor package thermal resistance is present, the maximum ambient temperature may have to be derated. Maximum ambient temperature (T_{A-MAX}) is dependent on the maximum operating junction temperature ($T_{J-MAX-OP} = 125^{\circ}\text{C}$), the maximum power dissipation of the device in the application (P_{D-MAX}), and the junction-to ambient thermal resistance of the part/package in the application (θ_{JA}), as given by the following equation: $T_{A-MAX} = T_{J-MAX-OP} - (\theta_{JA} \times P_{D-MAX})$.

Note 6: Junction-to-ambient thermal resistance (θ_{JA}) is taken from thermal measurements, performed under the conditions and guidelines set forth in the JEDEC standard JESD51-7. A 4 layer, 4" x 4", 2/1/1/2 oz. Cu board as per JEDEC standards is used for the measurements.

Note 7: Min and Max limits are guaranteed by design, test, or statistical analysis. Typical numbers are not guaranteed, but do represent the most likely norm. Due to the pulsed nature of the testing $T_A = T_J$ for the electrical characteristics table.

Note 8: The parameters in the electrical characteristics table are tested under open loop conditions at $PV_{IN} = V_{DD} = 3.6\text{V}$. For performance over the input voltage range and closed loop results refer to the datasheet curves.

Note 9: Shutdown current includes leakage current of PFET.

Note 10: I_Q specified here is when the part is operating at 100% duty cycle.

Note 11: Current limit is built-in, fixed, and not adjustable. Refer to datasheet curves for closed loop data and its variation with regards to supply voltage and temperature. Electrical Characteristic table reflects open loop data ($FB = 0\text{V}$ and current drawn from SW pin ramped up until cycle by cycle limit is activated). Closed loop current limit is the peak inductor current measured in the application circuit by increasing output current until output voltage drops by 10%.

Note 12: Ripple voltage should be measured at C_{OUT} electrode on good layout PC board and under condition using suggested inductors and capacitors.

Note 13: National Semiconductor recommends that all integrated circuits be handled with appropriate precautions. Failure to observe proper ESD handling techniques can result in damage.

Note 14: Performance listed was taken using the FDK (MIPSA2520D3R3). Please refer to Inductor selection guide in Application Information section for proper inductor selection.

Typical Performance Characteristics (Circuit in Figure 3, $PV_{IN} = V_{DD} = EN = 3.6V$, $L = 3.3\mu H$ (Note 14), DCR of $L \leq 100m\Omega$ (FDK, MIPS2520D3R3), $C_{IN} = 10\mu F$, 0603, 6.3V (TDK, 1608X5R0J106M), $C_{OUT} = 10\mu F$, 0603, 6.3V (TDK, 1608X5R0J106M) unless otherwise noted.

Quiescent Current vs Supply Voltage (No Switching)

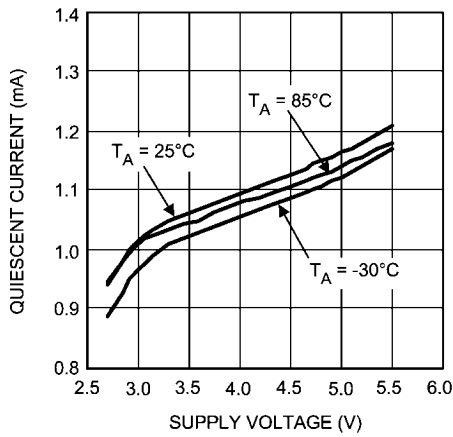

20198957

Shutdown Current vs Temperature (EN = 0V)

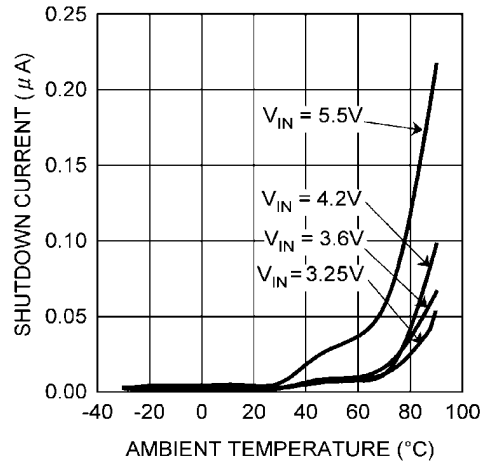

20198956

Switching Frequency Variation vs Temperature ($V_{OUT} = 3.09V$, $I_{OUT} = 200mA$)

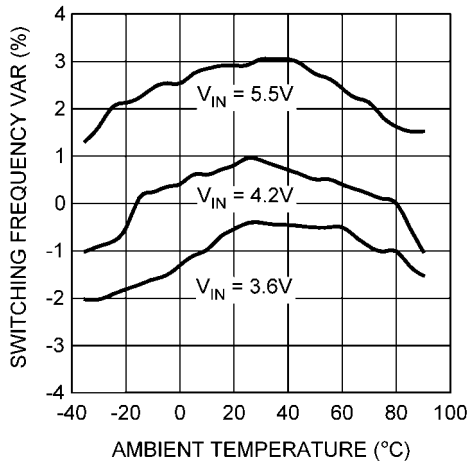

20198962

Output Voltage vs Supply Voltage ($V_{OUT} = 3.09V$)

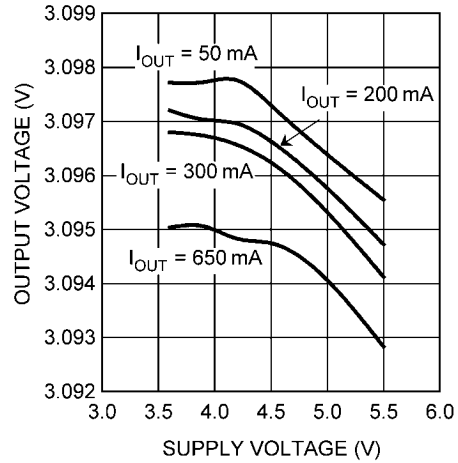

20198963

Output Voltage vs Temperature
 ($V_{IN} = 3.6V$, $V_{OUT} = 3.09V$)

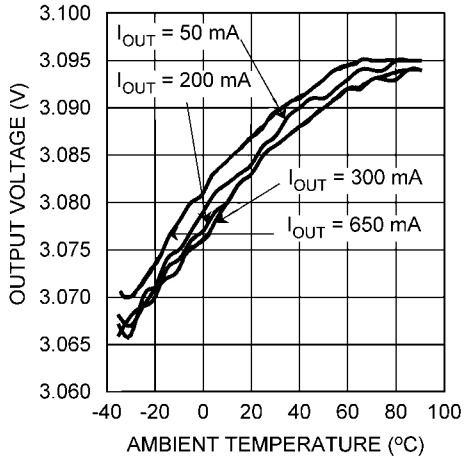

20198964

Open/Closed Loop Current Limit vs Temperature
 (PWM mode)

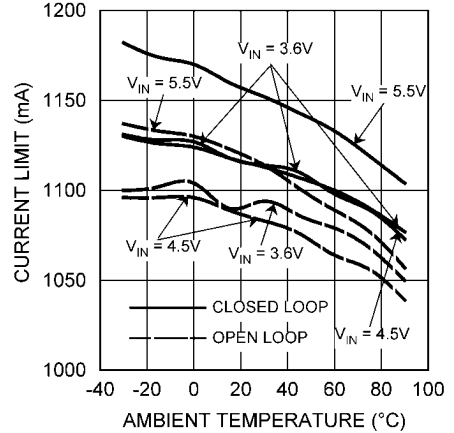

20198961

Efficiency vs Output Current
 ($V_{OUT} = 3.09V$)

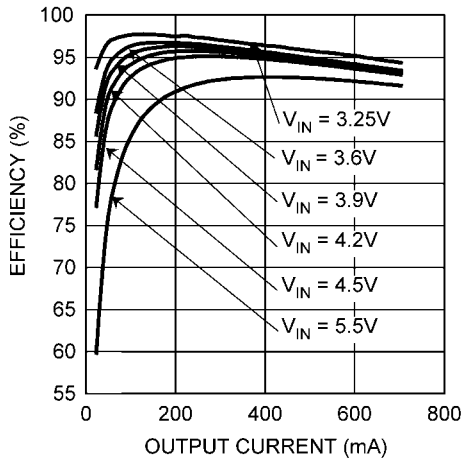

20198965

Load Transient Response
 ($V_{OUT} = 3.09V$)

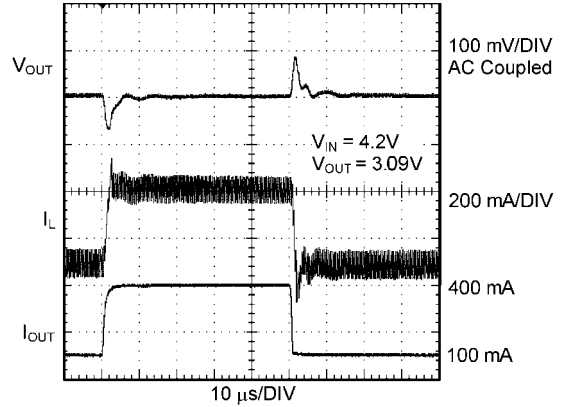

20198917

Startup
 ($V_{IN} = 3.6V$, $V_{OUT} = 3.09V$, $I_{OUT} < 1mA$)

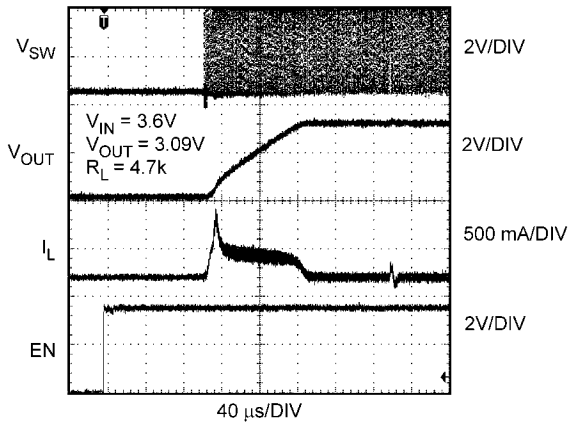

20198976

Startup
 ($V_{IN} = 4.2V$, $V_{OUT} = 3.09V$, $I_{OUT} < 1mA$)

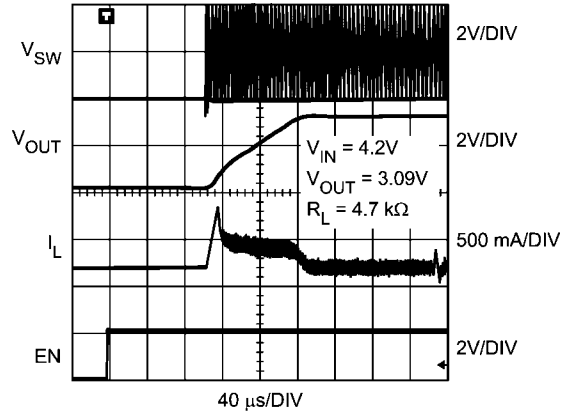

20198983

Shutdown Response
 ($V_{IN} = 3.6V$, $V_{OUT} = 3.09V$, $R_{LOAD} = 5\ \Omega$)

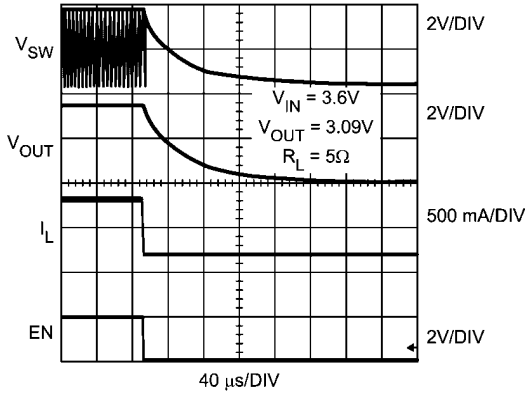

20198921

Shutdown Response
 ($V_{IN} = 4.2V$, $V_{OUT} = 3.09V$, $R_{LOAD} = 5\ \Omega$)

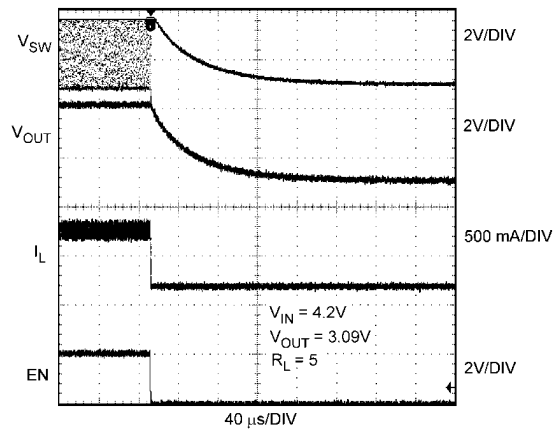

20198919

Line Transient Response
 ($V_{IN} = 3.3V$ to $3.9V$, $I_{OUT} = 100mA$)

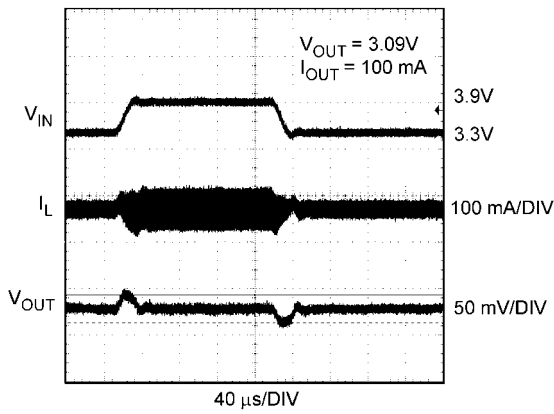

20198920

Timed Current Limit Response
 ($V_{IN} = 3.6V$)

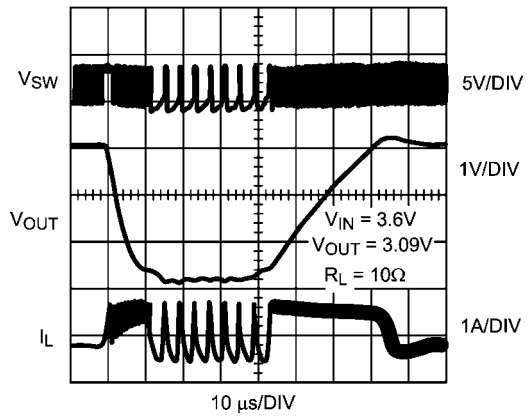

20198977

Output Voltage Ripple
 ($V_{OUT} = 3.09V$)

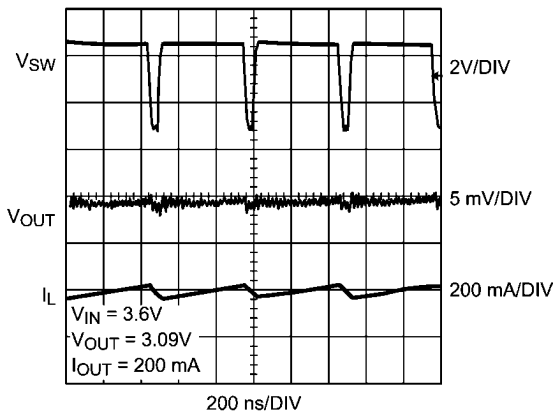

20198978

Output Voltage Ripple in Pulse Skip
 ($V_{IN} = 3.310V$, $V_{OUT} = 3.09V$, $R_{LOAD} = 5\ \Omega$)

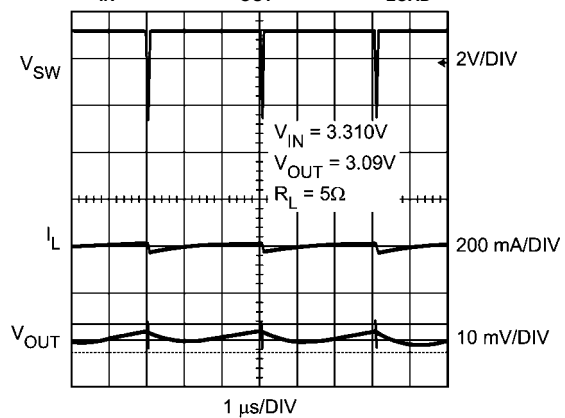

20198980

**R_{DS(on)} vs Temperature
(P-ch, I_{SW} = 200mA)**

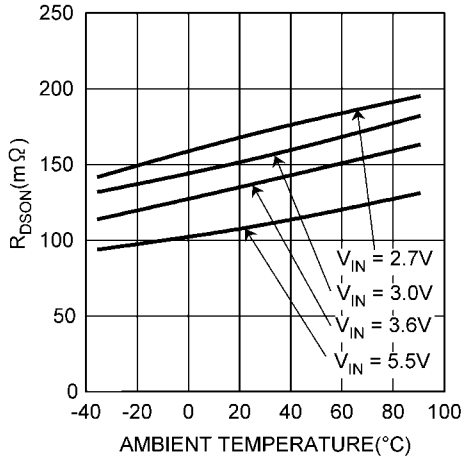

**R_{DS(on)} vs Temperature
(N-ch, I_{SW} = -200mA)**

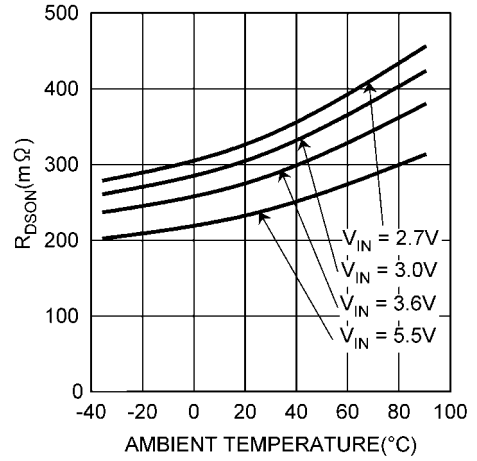

EN High Threshold vs. Vin

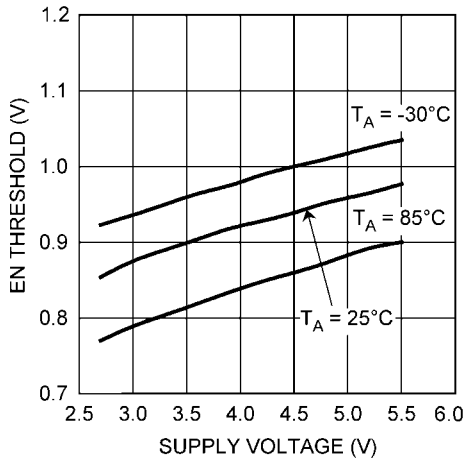

Block Diagram

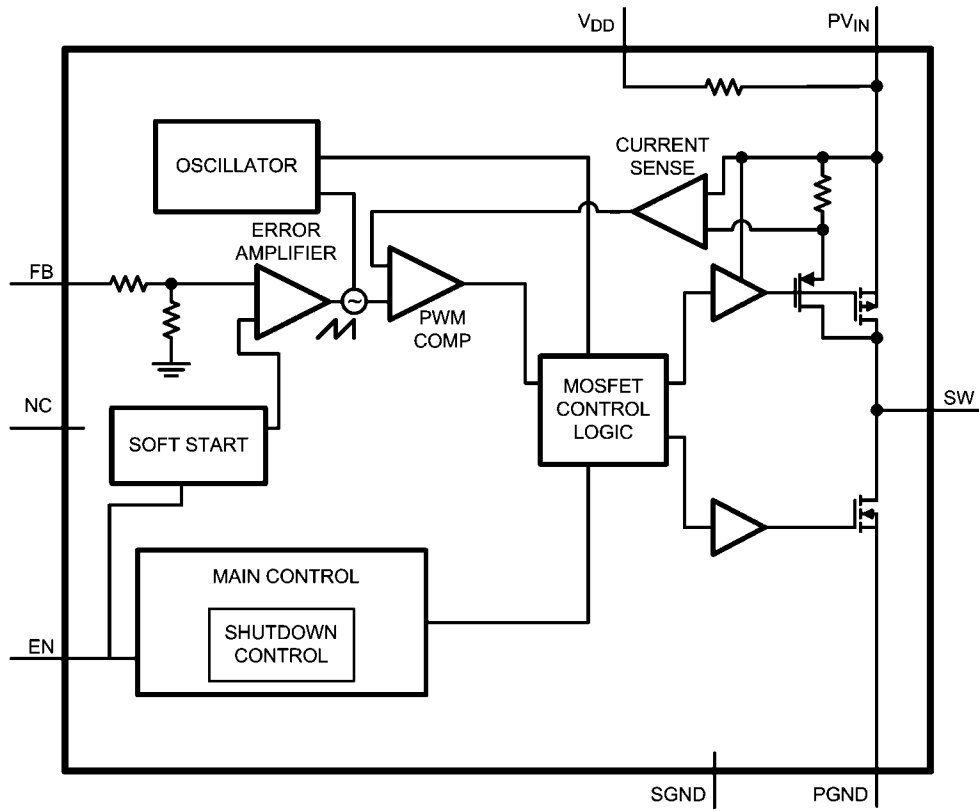

20198935

FIGURE 2. Functional Block Diagram

Operation Description

The LM3206 is a simple, step-down DC-DC converter optimized for powering portable applications which require low dropout voltages such as mobile phones, portable communicators, and similar battery powered RFIC devices. It is designed to allow the application to operate at maximum efficiency over a wide range of power levels from a single Li-Ion battery cell. It is based on a current-mode buck architecture, with synchronous rectification for high efficiency. It is designed for a maximum load capability of 650mA in PWM mode.

The maximum load range may vary from this depending on input voltage, output voltage and the inductor chosen.

Efficiency is typically 96% for a 400mA load with a 3.6V input, and a fixed output voltage of 3.09V.

Additional features include current overload protection, thermal overload shutdown and soft start.

The LM3206 is constructed using a chip-scale 8-pin micro SMD package. This package offers the smallest possible size for space-critical applications such as cell phones, where board area is an important design consideration. Use of a high switching frequency (2MHz) reduces the size of external components. As shown in *Figure 3*, only three external power components are required for implementation. Use of a micro SMD package requires special design considerations for implementation. (See Micro SMD Package Assembly and use in the Applications Information section.) Its fine bump-pitch requires careful board design and precision assembly equipment. Use of this package is best suited for opaque-case applications, where its edges are not subject to high-intensity ambient red or infrared light. Also, the system controller should set EN low during power-up and other low supply voltage conditions. (See Shutdown Mode in the Device Information section.)

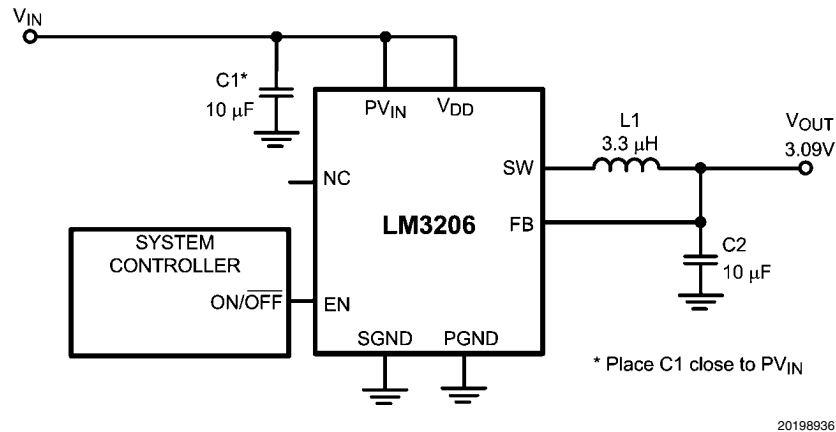

FIGURE 3. Typical Operating System Circuit

Circuit Operation

Referring to *Figure 2* and *Figure 3*, the LM3206 operates as follows. During the first part of each switching cycle, the control block in the LM3206 turns on the internal PFET (P-channel MOSFET) switch. This allows current to flow from the input through the inductor to the output filter capacitor and load. The inductor limits the current to a ramp with a slope of around $(V_{IN} - V_{OUT}) / L$, by storing energy in a magnetic field. During the second part of each cycle, the controller turns the PFET switch off, blocking current flow from the input, and then turns the NFET (N-channel MOSFET) synchronous rectifier on. In response, the inductor's magnetic field collapses, generating a voltage that forces current from ground through the synchronous rectifier to the output filter capacitor and load. As the stored energy is transferred back into the circuit and depleted, the inductor current ramps down with a slope around V_{OUT} / L . The output filter capacitor stores charge when the inductor current is high, and releases it when low, smoothing the voltage across the load.

The output voltage is regulated by modulating the PFET switch on time to control the average current sent to the load. The effect is identical to sending a duty-cycle modulated rectangular wave formed by the switch and synchronous rectifier at SW to a low-pass filter formed by the inductor and output

filter capacitor. The output voltage is equal to the average voltage at the SW pin.

While in operation, the output voltage is regulated by switching at a constant frequency and then modulating the energy per cycle to control power to the load. Energy per cycle is set by modulating the PFET switch on-time pulse width to control the peak inductor current. This is done by comparing the signal from the current-sense amplifier with a slope compensated error signal from the voltage-feedback error amplifier. At the beginning of each cycle, the clock turns on the PFET switch, causing the inductor current to ramp up. When the current sense signal ramps past the error amplifier signal, the PWM comparator turns off the PFET switch and turns on the NFET synchronous rectifier, ending the first part of the cycle. If an increase in load pulls the output down, the error amplifier output increases, which allows the inductor current to ramp higher before the comparator turns off the PFET. This increases the average current sent to the output and adjusts for the increase in the load.

Before appearing at the PWM comparator, a slope compensation ramp from the oscillator is subtracted from the error signal for stability of the current feedback loop. The minimum on time of PFET in PWM mode is 50ns (typ.)

Shutdown Mode

Setting the EN digital pin low (<0.5V) places the LM3206 in a 0.01µA (typ.) Shutdown mode. During shutdown, the PFET switch, NFET synchronous rectifier, reference voltage source, control and bias circuitry of the LM3206 are turned off. Setting EN high (>1.2V) enables normal operation.

EN should be set low to turn off the LM3206 during power-up and under voltage conditions when the power supply is less than the 2.7V minimum operating voltage. The LM3206 is designed for compact portable applications, such as mobile phones. In such applications, the system controller determines power supply sequencing and requirements for small package size outweigh the additional size required for inclusion of UVLO (Under Voltage Lock-Out) circuitry.

Internal Synchronous Rectification

The LM3206 uses an internal NFET as a synchronous rectifier to reduce rectifier forward voltage drop and associated power loss. Synchronous rectification provides a significant improvement in efficiency whenever the output voltage is relatively low compared to the voltage drop across an ordinary rectifier diode.

The internal NFET synchronous rectifier is turned on during the inductor current down slope in the second part of each cycle. The synchronous rectifier is turned off prior to the next cycle. The NFET is designed to conduct through its intrinsic body diode during transient intervals before it turns on, eliminating the need for an external diode.

Current Limiting

A current limit feature allows the LM3206 to protect itself and external components during overload conditions. In PWM mode, a 1200mA (max.) cycle-by-cycle current limit is normally used. If an excessive load pulls the output voltage down to approximately 0.375V, then the device switches to a timed current limit mode. In timed current limit mode the internal PFET switch is turned off after the current comparator trips and the beginning of the next cycle is inhibited for 3.5µs to force the instantaneous inductor current to ramp down to a safe value. The synchronous rectifier is off in timed current limit mode. Timed current limit prevents the loss of current control seen in some products when the output voltage is pulled low in serious overload conditions.

Thermal Overload Protection

The LM3206 has a thermal overload protection function that operates to protect itself from short-term misuse and overload conditions. When the junction temperature exceeds around 150°C, the device inhibits operation. Both the PFET and the NFET are turned off in PWM mode. When the temperature drops below 125°C, normal operation resumes. Prolonged operation in thermal overload conditions may damage the device and is considered bad practice.

Application Information

INDUCTOR SELECTION

A 3.3µH inductor with saturation current rating over 1200mA and low inductance drop at the full DC bias condition is recommended for almost all applications. The inductor's DC resistance should be less than 0.2Ω for good efficiency. For low dropout voltage, lower DCR inductors are advantageous. The lower limit of acceptable inductance is 2.3µH at 400mA over the operating temperature range. Full attention should

be paid to this limit, because some small inductors show large inductance drops at high DC bias. These can not be used with the LM3206. *Table 1* suggests some inductors and suppliers. There are two methods to choose the inductor saturation current rating.

Method 1:

The saturation current should be greater than the sum of the maximum load current and the worst case average to peak inductor current. This can be written as

$$I_{SAT} > I_{OUTMAX} + I_{RIPPLE}$$

$$\text{where } I_{RIPPLE} = \left(\frac{V_{IN} - V_{OUT}}{2 * L} \right) * \left(\frac{V_{OUT}}{V_{IN}} \right) * \left(\frac{1}{f} \right)$$

- I_{RIPPLE} : average to peak inductor current
- I_{OUTMAX} : maximum load current (≤ 650mA)
- V_{IN} : maximum input voltage in application
- L : min inductor value including worst case tolerances (30% drop can be considered for method 1)
- f : minimum switching frequency (1.7Mhz)
- V_{OUT} : output voltage

Method 2:

A more conservative and recommended approach is to choose an inductor that has a saturation current rating greater than the maximum current limit of 1200mA.

TABLE 1. Suggested inductors and their suppliers

Model	Size (WxLxH) [mm]	Vendor
MIPSA2520D3R3	2.5 x 2.0 x 1.2	FDK
MIPW3226D3R0M	3.2 x 2.6 x 1.0	FDK
NR3012T3R3M	3.0 x 3.0 x 1.2	Taiyo-Yuden
1098AS-3R3M	3.0 x 2.8 x 1.2	TOKO

Inductor MIPSA2520D3R3 is recommended to be used in applications of < 400mA load current. The other three inductors may be used in applications of > 400mA load current. If a smaller inductance inductor is used incorrectly for the wrong application, the LM3206 may become unstable during line and load transients.

For low-cost applications, an unshielded bobbin inductor is suggested. For noise-critical applications, a toroidal or shielded-bobbin inductor should be used. A good practice is to lay out the board with footprints accommodating both types for design flexibility. This allows substitution of a low-noise toroidal inductor, in the event that noise from low-cost bobbin models is unacceptable. Saturation occurs when the magnetic flux density from current through the windings of the inductor exceeds what the inductor's core material can support with a corresponding magnetic field. This can cause poor efficiency, regulation errors or stress to a DC-DC converter like the LM3206.

CAPACITOR SELECTION

The LM3206 is designed for use with a 10µF ceramic capacitors for its input and output filters. They should maintain at least 50% capacitance at DC bias and temperature conditions. Ceramic capacitors types such as X5R, X7R are recommended for both filters. These provide an optimal balance between small size, cost, reliability and performance for cell phones and similar applications. *Table 2* lists the suggested part number and supplier. DC bias characteristics of the ca-

capacitors must be considered when selecting the voltage rating and case size of the capacitor.

TABLE 2. Suggested capacitor and their supplier

Model	Vendor
C1608X5R0J106M, 10 μ F, 6.3V	TDK
C2012X5R0J106M, 10 μ F, 6.3V	TDK

The input filter capacitor supplies AC current drawn by the PFET switch of the LM3206 in the first part of each cycle and reduces the voltage ripple imposed on the input power source. The output filter capacitor absorbs the AC inductor current, helps maintain a steady output voltage during transient load changes and reduces output voltage ripple. These capacitors must be selected with sufficient capacitance and sufficiently low ESR (Equivalent Series Resistance) to perform these functions. The ESR of the filter capacitors is generally a major factor in voltage ripple.

EN PIN CONTROL

Drive the EN pin using the system controller to turn the LM3206 ON and OFF. Use a comparator, Schmidt trigger or logic gate to drive the EN pin. Set EN high (>1.2V) for normal operation and low (<0.5V) for a 0.01 μ A (typ.) shutdown mode. Set EN low to turn off the LM3206 during power-up and under voltage conditions when the power supply is less than the 2.7V minimum operating voltage. The part is out of regulation when the input voltage is less than 2.7V. The LM3206 is designed for mobile phones where the system controller controls operation mode for maximizing battery life and requirements for small package size outweigh the additional size required for inclusion of UVLO (Under Voltage Lock-Out) circuitry.

Micro SMD PACKAGE ASSEMBLY AND USE

Use of the Micro SMD package requires specialized board layout, precision mounting and careful re-flow techniques, as

BOARD LAYOUT CONSIDERATIONS

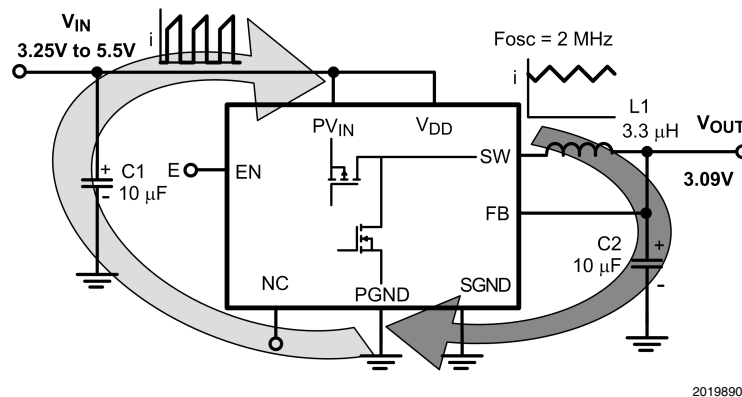

FIGURE 4. Current Loop

The LM3206 converts higher input voltage to lower output voltage with high efficiency. This is achieved with an inductor-based switching topology. During the first half of the switching cycle, the internal PMOS switch turns on, the input voltage is applied to the inductor, and the current flows from P_{VDD} line to the output capacitor (C2) through the inductor. During the second half cycle, the PMOS turns off and the internal NMOS

detailed in National Semiconductor Application Note 1112. Refer to the section *Surface Mount Technology (SMD) Assembly Considerations*. For best results in assembly, alignment ordinals on the PC board should be used to facilitate placement of the device. The pad style used with Micro SMD package must be the NSMD (non-solder mask defined) type. This means that the solder-mask opening is larger than the pad size. This prevents a lip that otherwise forms if the solder-mask and pad overlap, from holding the device off the surface of the board and interfering with mounting. See Application Note 1112 for specific instructions how to do this.

The 8-Bump package used for LM3206 has 300micron solder balls and requires 10.82mil pads for mounting on the circuit board. The trace to each pad should enter the pad with a 90° entry angle to prevent debris from being caught in deep corners. Initially, the trace to each pad should be 7mil wide, for a section approximately 7mil long, as a thermal relief. Then each trace should neck up or down to its optimal width. The important criterion is symmetry. This ensures the solder bumps on the LM3206 re-flow evenly and that the device solders level to the board. In particular, special attention must be paid to the pads for bumps A1, A3 and B3. Because PGND and PVIN are typically connected to large copper planes, inadequate thermal relief's can result in late or inadequate re-flow of these bumps.

The Micro SMD package is optimized for the smallest possible size in applications with red or infrared opaque cases. Because the Micro SMD package lacks the plastic encapsulation characteristic of larger devices, it is vulnerable to light. Backside metallization and/or epoxy coating, along with front-side shading by the printed circuit board, reduce this sensitivity. However, the package has exposed die edges. In particular, Micro SMD devices are sensitive to light, in the red and infrared range, shining on the package's exposed die edges.

turns on. The inductor current continues to flow via the inductor from the device PGND line to the output capacitor (C2). Referring to Figure 4, the LM3206 has two major current loops where pulse and ripple current flow. The loop shown in the left hand side is most important, because pulse current shown in Figure 4 flows in this path. The right hand side is next. The current waveform in this path is triangular, as shown in Figure 4. Pulse current has many high-frequency components due

to fast di/dt . Triangular ripple current also has wide high-frequency components. Board layout and circuit pattern design of these two loops are the key factors for reducing noise radiation and stable operation. Other lines, such as from battery

to C1(+) and C2(+) to load, are almost DC current, so it is not necessary to take so much care. Only pattern width (current capability) and DCR drop considerations are needed.

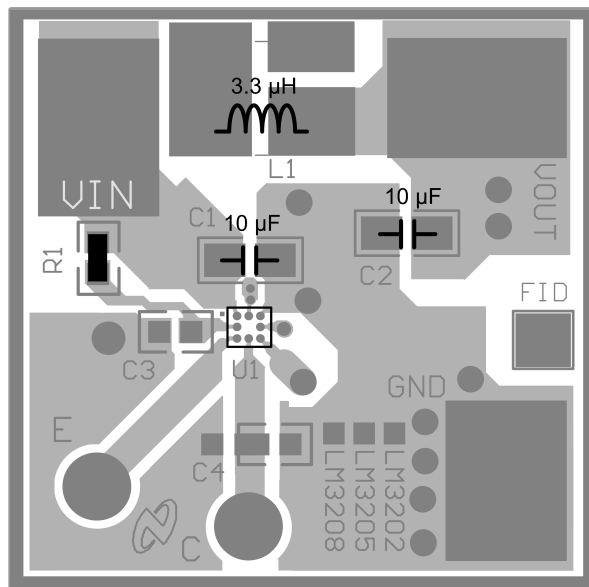

20198909

FIGURE 5. Evaluation Board Layout

BOARD LAYOUT FLOW

1. Minimize C1, PV_{IN} , and PGND loop. These traces should be as wide and short as possible. This is most important.
2. Minimize L1, C2, SW and PGND loop. These traces also should be wide and short. This is the second priority.
3. Above layout patterns should be placed on the component side of the PCB to minimize parasitic inductance and resistance due to via-holes. It may be a good idea that the SW to L1 path is routed between C2 (+) and C2(-) land patterns. If vias are used in these large current paths, multiple via-holes should be used if possible.
4. Connect C1(-), C2(-) and PGND with wide GND pattern. This pattern should be short, so C1(-), C2(-), and PGND should be as close as possible. Then connect to a PCB common GND pattern with as many via-holes as possible.
5. SGND should not connect directly to PGND. Connecting these pins under the device should be avoided. (If possible, connect SGND to the common port of C1(-), C2 (-) and PGND.)
6. V_{DD} should not be connected directly to PV_{IN} . Connecting these pins under the device should be avoided. It is good idea to connect V_{DD} to the C1(+) to avoid switching noise injection to the V_{DD} line.
7. FB line should be protected from noise. It is a good idea to use an inner GND layer (if available) as a shield.
8. The "C" connection trace is not used because the LM3206 has the NC (no connect) at the part.

Note: The evaluation board shown in *Figure 5* for the LM3206 was designed with these considerations, and it shows good performance. However some aspects have not been optimized because of limitations due to evaluation-specific requirements. The board can be used as a reference, but it is not the best. Please refer questions to a National representative.

Physical Dimensions inches (millimeters) unless otherwise noted

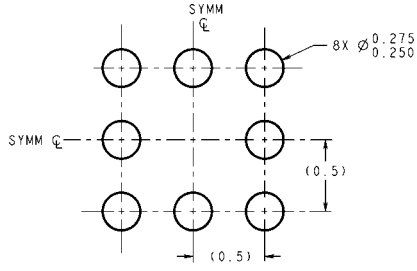

LAND PATTERN RECOMMENDATION

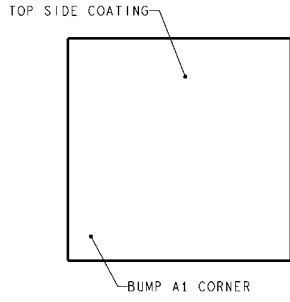

DIMENSIONS ARE IN MILLIMETERS
DIMENSIONS IN () FOR REFERENCE ONLY

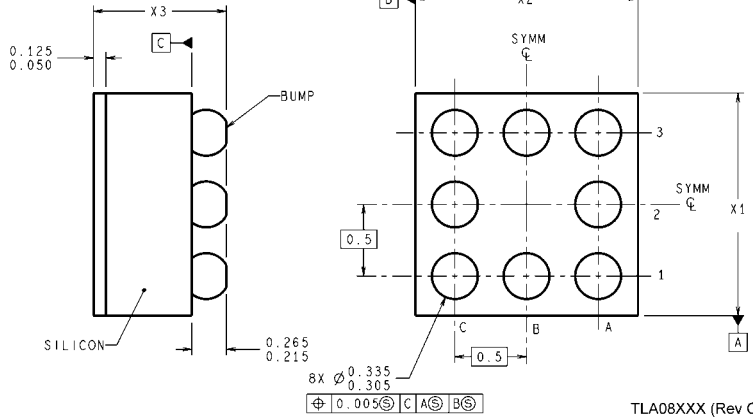

TLA08XXX (Rev C)

8-Bump Thin Micro SMD, Large Bump
X1 = 1.666mm ± 0.030mm
X2 = 1.819mm ± 0.030mm
X3 = 0.600mm ± 0.075mm
NS Package Number TLA08HPA

Notes

LM3206

Notes

THE CONTENTS OF THIS DOCUMENT ARE PROVIDED IN CONNECTION WITH NATIONAL SEMICONDUCTOR CORPORATION ("NATIONAL") PRODUCTS. NATIONAL MAKES NO REPRESENTATIONS OR WARRANTIES WITH RESPECT TO THE ACCURACY OR COMPLETENESS OF THE CONTENTS OF THIS PUBLICATION AND RESERVES THE RIGHT TO MAKE CHANGES TO SPECIFICATIONS AND PRODUCT DESCRIPTIONS AT ANY TIME WITHOUT NOTICE. NO LICENSE, WHETHER EXPRESS, IMPLIED, ARISING BY ESTOPPEL OR OTHERWISE, TO ANY INTELLECTUAL PROPERTY RIGHTS IS GRANTED BY THIS DOCUMENT.

TESTING AND OTHER QUALITY CONTROLS ARE USED TO THE EXTENT NATIONAL DEEMS NECESSARY TO SUPPORT NATIONAL'S PRODUCT WARRANTY. EXCEPT WHERE MANDATED BY GOVERNMENT REQUIREMENTS, TESTING OF ALL PARAMETERS OF EACH PRODUCT IS NOT NECESSARILY PERFORMED. NATIONAL ASSUMES NO LIABILITY FOR APPLICATIONS ASSISTANCE OR BUYER PRODUCT DESIGN. BUYERS ARE RESPONSIBLE FOR THEIR PRODUCTS AND APPLICATIONS USING NATIONAL COMPONENTS. PRIOR TO USING OR DISTRIBUTING ANY PRODUCTS THAT INCLUDE NATIONAL COMPONENTS, BUYERS SHOULD PROVIDE ADEQUATE DESIGN, TESTING AND OPERATING SAFEGUARDS.

EXCEPT AS PROVIDED IN NATIONAL'S TERMS AND CONDITIONS OF SALE FOR SUCH PRODUCTS, NATIONAL ASSUMES NO LIABILITY WHATSOEVER, AND NATIONAL DISCLAIMS ANY EXPRESS OR IMPLIED WARRANTY RELATING TO THE SALE AND/OR USE OF NATIONAL PRODUCTS INCLUDING LIABILITY OR WARRANTIES RELATING TO FITNESS FOR A PARTICULAR PURPOSE, MERCHANTABILITY, OR INFRINGEMENT OF ANY PATENT, COPYRIGHT OR OTHER INTELLECTUAL PROPERTY RIGHT.

LIFE SUPPORT POLICY

NATIONAL'S PRODUCTS ARE NOT AUTHORIZED FOR USE AS CRITICAL COMPONENTS IN LIFE SUPPORT DEVICES OR SYSTEMS WITHOUT THE EXPRESS PRIOR WRITTEN APPROVAL OF THE CHIEF EXECUTIVE OFFICER AND GENERAL COUNSEL OF NATIONAL SEMICONDUCTOR CORPORATION. As used herein:

Life support devices or systems are devices which (a) are intended for surgical implant into the body, or (b) support or sustain life and whose failure to perform when properly used in accordance with instructions for use provided in the labeling can be reasonably expected to result in a significant injury to the user. A critical component is any component in a life support device or system whose failure to perform can be reasonably expected to cause the failure of the life support device or system or to affect its safety or effectiveness.

National Semiconductor and the National Semiconductor logo are registered trademarks of National Semiconductor Corporation. All other brand or product names may be trademarks or registered trademarks of their respective holders.

Copyright© 2007 National Semiconductor Corporation

For the most current product information visit us at www.national.com



National Semiconductor Americas Customer Support Center
 Email: new.feedback@nsc.com
 Tel: 1-800-272-9959



National Semiconductor Europe Customer Support Center
 Fax: +49 (0) 180-530-85-86
 Email: europe.support@nsc.com
 Deutsch Tel: +49 (0) 69 9508 6208
 English Tel: +49 (0) 870 24 0 2171
 Français Tel: +33 (0) 1 41 91 8790

National Semiconductor Asia Pacific Customer Support Center
 Email: ap.support@nsc.com





National Semiconductor Japan Customer Support Center
 Fax: 81-3-5639-7507
 Email: jpn.feedback@nsc.com
 Tel: 81-3-5639-7560

Looking for pricing, stock, or lifecycle information?

Click below to explore more details on WIN SOURCE:

-  [View LM3206TLX on WIN SOURCE](#)
-  [Texas Instruments](#) Information

Optimize Your Supply Chain with WIN SOURCE Solutions

-  Global Sourcing Solution
-  Obsolete Management
-  Cost Control Management
-  Shortage Management
-  Alternative Solution
-  Excess Inventory Management