



# THE DATASHEET OF LM337KCSE3



## LMx37 3-Terminal Adjustable Regulators

### 1 Features

- Output Voltage Range Adjustable From  $-1.2\text{ V}$  to  $-37\text{ V}$
- Output Current Capability of  $1.5\text{ A}$  Max
- Input Regulation Typically  $0.01\%$  Per Input-Voltage Change
- Output Regulation Typically  $0.3\%$
- Peak Output Current Constant Over Temperature Range of Regulator
- Ripple Rejection Typically  $77\text{ dB}$
- Direct Replacement for Industry-Standard LM237 and LM337

### 2 Applications

- Applications Requiring Negative Output Voltage or Precision Current Regulation
- Consumer Electronics
- End Equipment
- Portable Applications

### 4 Simplified Schematic

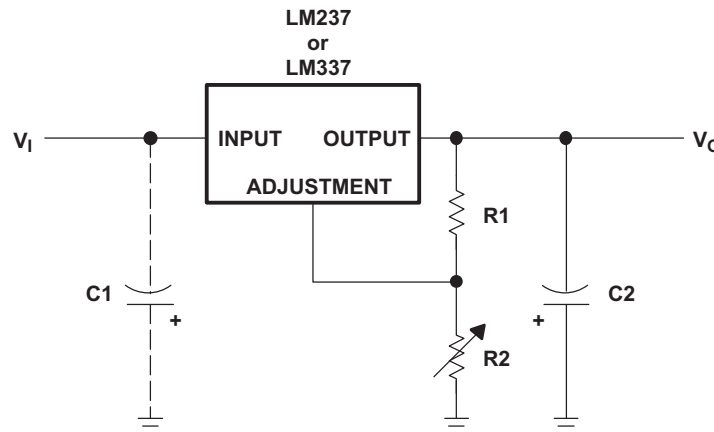

### 3 Description

The LM237 and LM337 are adjustable 3-terminal negative-voltage regulators capable of supplying in excess of  $-1.5\text{ A}$  over an output voltage range of  $-1.2\text{ V}$  to  $-37\text{ V}$ . They require only two external resistors to set the output voltage and one output capacitor for frequency compensation.

#### Device Information<sup>(1)</sup>

PART NUMBER	PACKAGE	BODY SIZE (NOM)
LMx37	TO-220 (4)	10.16 mm x 8.82 mm
	TO-263 (4)	10.16 mm x 9.02 mm
	TO-252 (4)	6.6 mm x 6.10 mm

(1) For all available packages, see the orderable addendum at the end of the data sheet.



## Table of Contents

<b>1 Features</b> .....	<b>1</b>	8.3 Design Schematic .....	<b>8</b>
<b>2 Applications</b> .....	<b>1</b>	8.4 Feature Description .....	<b>8</b>
<b>3 Description</b> .....	<b>1</b>	8.5 Device Functional Modes .....	<b>8</b>
<b>4 Simplified Schematic</b> .....	<b>1</b>	<b>9 Application and Implementation</b> .....	<b>9</b>
<b>5 Revision History</b> .....	<b>2</b>	9.1 Application Information .....	<b>9</b>
<b>6 Pin Configuration and Functions</b> .....	<b>3</b>	9.2 Typical Application .....	<b>9</b>
<b>7 Specifications</b> .....	<b>4</b>	<b>10 Power Supply Recommendations</b> .....	<b>10</b>
7.1 Absolute Maximum Ratings .....	<b>4</b>	<b>11 Layout</b> .....	<b>11</b>
7.2 ESD Ratings .....	<b>4</b>	11.1 Layout Guidelines .....	<b>11</b>
7.3 Recommended Operating Conditions .....	<b>4</b>	11.2 Layout Example .....	<b>11</b>
7.4 Thermal Information .....	<b>4</b>	<b>12 Device and Documentation Support</b> .....	<b>11</b>
7.5 Electrical Characteristics .....	<b>5</b>	12.1 Related Links .....	<b>11</b>
7.6 Electrical Characteristics .....	<b>5</b>	12.2 Trademarks .....	<b>11</b>
7.7 Typical Characteristics .....	<b>6</b>	12.3 Electrostatic Discharge Caution .....	<b>11</b>
<b>8 Detailed Description</b> .....	<b>7</b>	12.4 Glossary .....	<b>11</b>
8.1 Overview .....	<b>7</b>	<b>13 Mechanical, Packaging, and Orderable Information</b> .....	<b>11</b>
8.2 Functional Block Diagram .....	<b>7</b>		

## 5 Revision History

### Changes from Revision K (November 2007) to Revision L

**Page**

- Added *Applications*, *Device Information* table, *Pin Functions* table, *ESD Ratings* table, *Thermal Information* table, *Typical Characteristics*, *Feature Description* section, *Device Functional Modes*, *Application and Implementation* section, *Power Supply Recommendations* section, *Layout* section, *Device and Documentation Support* section, and *Mechanical, Packaging, and Orderable Information* section. .... **1**
- Deleted *Ordering Information* table. .... **1**

## 6 Pin Configuration and Functions

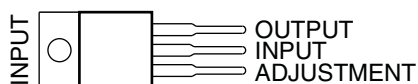
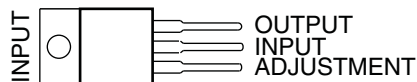
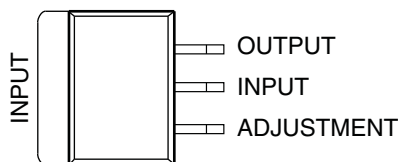
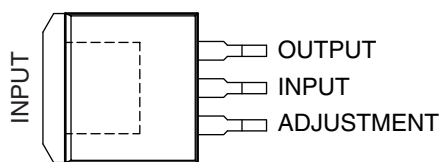
**LM237, LM337...KC (TO-220) PACKAGE  
(TOP VIEW)**

**LM337...KCS (TO-220) PACKAGE  
(TOP VIEW)**

**LM337...KTE, KTP, OR KVV PACKAGE  
(TOP VIEW)**

**LM337...KTT (TO-263) PACKAGE  
(TOP VIEW)**

### Pin Functions

PIN		TYPE	DESCRIPTION
NAME	NO.		
ADJUSTMENT	1	I	Adjustment pin for the output voltage. Connect two external resistors to adjust the output voltage.
INPUT	2	I	Input voltage. The input voltage and current will be designated $V_I$ and $I_I$ respectively.
OUTPUT	3	O	Output voltage. The output voltage and current will be designated $V_O$ and $I_O$ respectively.

## 7 Specifications

### 7.1 Absolute Maximum Ratings

over operating temperature ranges (unless otherwise noted)<sup>(1)</sup>

		MIN	MAX	UNIT
$V_I - V_O$	Input-to-output differential voltage		-40	V
$T_J$	Operating virtual junction temperature		150	°C
	Lead temperature	1.6 mm (1/16 in) from case for 10 s		°C
$T_{stg}$	Storage temperature range	-65	150	°C

- (1) Stresses beyond those listed under *Absolute Maximum Ratings* may cause permanent damage to the device. These are stress ratings only, and functional operation of the device at these or any other conditions beyond those indicated under *Recommended Operating Conditions* is not implied. Exposure to absolute-maximum-rated conditions for extended periods may affect device reliability.

### 7.2 ESD Ratings

		VALUE	UNIT
$V_{(ESD)}$	Electrostatic discharge	Human body model (HBM), per ANSI/ESDA/JEDEC JS-001, all pins <sup>(1)</sup>	1500
		Charged device model (CDM), per JEDEC specification JESD22-C101, all pins <sup>(2)</sup>	1500

- (1) JEDEC document JEP155 states that 500-V HBM allows safe manufacturing with a standard ESD control process.  
 (2) JEDEC document JEP157 states that 250-V CDM allows safe manufacturing with a standard ESD control process.

### 7.3 Recommended Operating Conditions

		MIN	MAX	UNIT
$V_I - V_O$	Input-to-output differential voltage	-2.5	-37	
$I_O$	Output current	$ V_I - V_O  \leq 40$ V, $P \leq 15$ W	10	1500
		$ V_I - V_O  \leq 10$ V, $P \leq 15$ W	6	1500
$T_J$	Operating virtual junction temperature	LM237	-25	150
		LM337	0	125

### 7.4 Thermal Information

THERMAL METRIC <sup>(1)</sup>	LM237	LMx37			LM337			UNIT
	KC	KCS	KTE	KTP	KTT	KVU		
	4 PINS	4 PINS	4 PINS	4 PINS	4 PINS	4 PINS		
$R_{\theta JA}$	Junction-to-ambient thermal resistance	24.8	24.8	23	28	25.3	30.3	°C/W
$R_{\theta JC(top)}$	Junction-to-case (top) thermal resistance	3	3	3	19	30.3	N/A	

- (1) For more information about traditional and new thermal metrics, see the *IC Package Thermal Metrics* application report ([SPRA953](#)).

## 7.5 Electrical Characteristics

over recommended ranges of operating virtual junction temperature (unless otherwise noted)

PARAMETER	TEST CONDITIONS <sup>(1)</sup>		LM237			LM337			UNIT
			MIN	TYP	MAX	MIN	TYP	MAX	
Input regulation <sup>(2)</sup>	$V_I - V_O = -3\text{ V to }-40\text{ V}$	$T_J = 25^\circ\text{C}$	0.01	0.02		0.01	0.04	%V	
		$T_J = \text{MIN to MAX}$	0.02	0.05		0.02	0.07		
Ripple rejection	$V_O = -10\text{ V}, f = 120\text{ Hz}$		60			60			dB
	$V_O = -10\text{ V}, f = 120\text{ Hz}, C_{\text{ADJ}} = 10\ \mu\text{F}$		66	77		66	77		
Output regulation	$I_O = 10\text{ mA to }1.5\text{ A}, T_J = 25^\circ\text{C}$	$ V_O  \leq 5\text{ V}$	25			50			mV
		$ V_O  \geq 5\text{ V}$	0.3%	0.5%		0.3%	1%	—	
	$I_O = 10\text{ mA to }1.5\text{ A}$	$ V_O  \leq 5\text{ V}$	50			70			mV
		$ V_O  \geq 5\text{ V}$	1%			1.5%			—
Output-voltage change with temperature	$T_J = \text{MIN to MAX}$		0.6%			0.6%			—
Output-voltage long-term drift	After 1000 h at $T_J = \text{MAX}$ and $V_I - V_O = -40\text{ V}$		0.3%	1%		0.3%	1%	—	
Output noise voltage	$f = 10\text{ Hz to }10\text{ kHz}, T_J = 25^\circ\text{C}$		0.003%			0.003%			—
Minimum output current to maintain regulation	$ V_I - V_O  \leq 40\text{ V}$		2.5	5		2.5	10	mA	
	$ V_I - V_O  \leq 10\text{ V}$		1.2	3		1.5	6		
Peak output current	$ V_I - V_O  \leq 15\text{ V}$		1.5	2.2		1.5	2.2	A	
	$ V_I - V_O  \leq 40\text{ V}, T_J = 25^\circ\text{C}$		0.24	0.4		0.15	0.4		
ADJUSTMENT current			65	100		65	100	$\mu\text{A}$	
Change in ADJUSTMENT current	$V_I - V_O = -2.5\text{ V to }-40\text{ V}, I_O = 10\text{ mA to MAX}, T_J = 25^\circ\text{C}$		2	5		2	5	$\mu\text{A}$	
Reference voltage (OUTPUT to ADJUSTMENT)	$V_I - V_O = -3\text{ V to }-40\text{ V}, I_O = 10\text{ mA to }1.5\text{ A}, P \leq \text{rated dissipation}$	$T_J = 25^\circ\text{C}$	-1.225	-1.25	-1.275	-1.213	-1.25	-1.287	V
		$T_J = \text{MIN to MAX}$	-1.2	-1.25	-1.3	-1.2	-1.25	-1.3	
Thermal regulation	Initial $T_J = 25^\circ\text{C}$ , 10-ms pulse		0.002	0.02		0.003	0.04	%/W	

- Unless otherwise noted, the following test conditions apply:  $|V_I - V_O| = 5\text{ V}$  and  $I_O = 0.5\text{ A}$ . For conditions shown as MIN or MAX, use the appropriate value specified under recommended operating conditions. All characteristics are measured with a 0.1- $\mu\text{F}$  capacitor across the input and a 1- $\mu\text{F}$  capacitor across the output. Pulse-testing techniques are used to maintain the junction temperature as close to the ambient temperature as possible. Thermal effects must be taken into account separately.
- Input regulation is expressed here as the percentage change in output voltage per 1-V change at the input.

## 7.6 Electrical Characteristics

$T_J = 25^\circ\text{C}$

PARAMETER	TEST CONDITIONS <sup>(1)</sup>		LM237, LM337			UNIT
			MIN	TYP	MAX	
Input regulation <sup>(2)</sup>	$V_I - V_O = -3\text{ V to }-40\text{ V}$			0.01	0.04	%V
Ripple rejection	$V_O = -10\text{ V}, f = 120\text{ Hz}$		60			dB
	$V_O = -10\text{ V}, f = 120\text{ Hz}, C_{\text{ADJ}} = 10\ \mu\text{F}$		66	77		
Output regulation	$I_O = 10\text{ mA to }1.5\text{ A}$	$ V_O  \leq 5\text{ V}$	50			mV
		$ V_O  \geq 5\text{ V}$	0.3%	1%		—
Output noise voltage	$f = 10\text{ Hz to }10\text{ kHz}$		0.003%			—
Minimum output current to maintain regulation	$ V_I - V_O  \leq 40\text{ V}$		2.5	10		mA
	$ V_I - V_O  \leq 10\text{ V}$		1.5	6		
Peak output current	$ V_I - V_O  \leq 15\text{ V}$		1.5	2.2		A
	$ V_I - V_O  \leq 40\text{ V}$		0.15	0.4		
ADJUSTMENT current			65	100		$\mu\text{A}$
Change in ADJUSTMENT current	$V_I - V_O = -2.5\text{ V to }-40\text{ V}, I_O = 10\text{ mA to MAX}$		2	5		$\mu\text{A}$
Reference voltage (OUTPUT to ADJUSTMENT)	$V_I - V_O = -3\text{ V to }-40\text{ V}, I_O = 10\text{ mA to }1.5\text{ A}, P \leq \text{rated dissipation}$		-1.213	-1.25	-1.287	V

- Unless otherwise noted, the following test conditions apply:  $|V_I - V_O| = 5\text{ V}$  and  $I_O = 0.5\text{ A}$ . All characteristics are measured with a 0.1- $\mu\text{F}$  capacitor across the input and a 1- $\mu\text{F}$  capacitor across the output. Pulse-testing techniques are used to maintain the junction temperature as close to the ambient temperature as possible. Thermal effects must be taken into account separately.
- Input regulation is expressed here as the percentage change in output voltage per 1-V change at the input.

## 7.7 Typical Characteristics

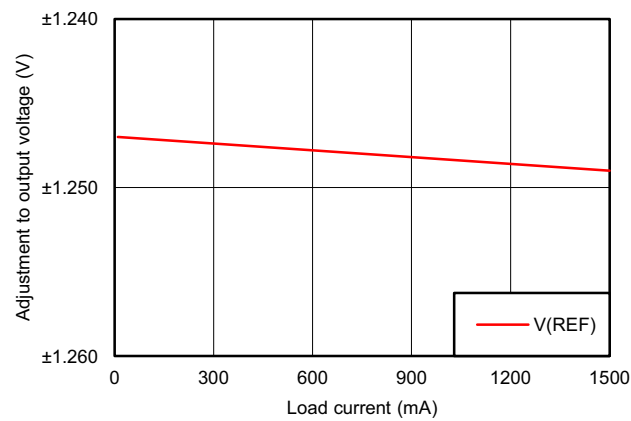

**Figure 1. Adjustment Voltage vs Load current ( $V_{IN} = -4.3$  V)**

## 8 Detailed Description

### 8.1 Overview

The LMx37 devices are adjustable 3-terminal negative-voltage regulators capable of supplying in excess of  $-1.5$  A over an output voltage range of  $-1.2$  V to  $-37$  V. They are exceptionally easy to use, requiring only two external resistors to set the output voltage and one output capacitor for frequency compensation. The current design is optimized for excellent regulation and low thermal transients. In addition, LM237 and LM337 feature internal current limiting, thermal shutdown, and safe-area compensation, making them virtually immune to failure by overloads. The LMx37 devices serve a wide variety of applications, including local on-card regulation, programmable output-voltage regulation, and precision current regulation.

### 8.2 Functional Block Diagram

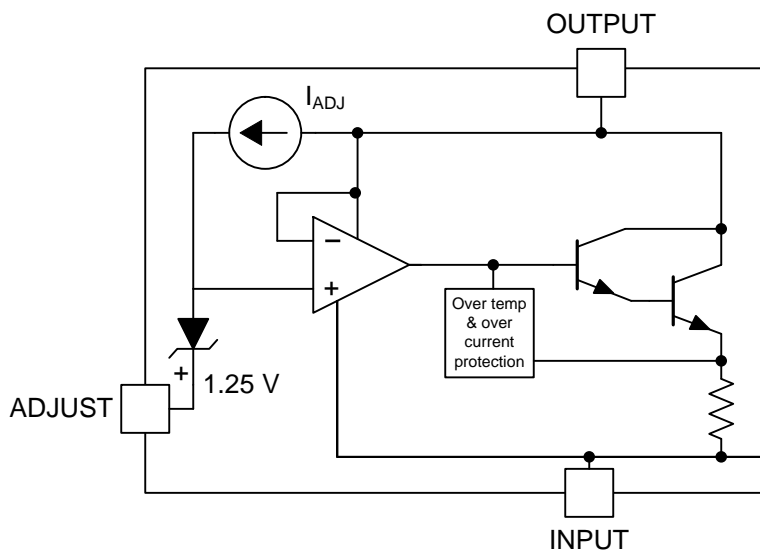

## 8.3 Design Schematic

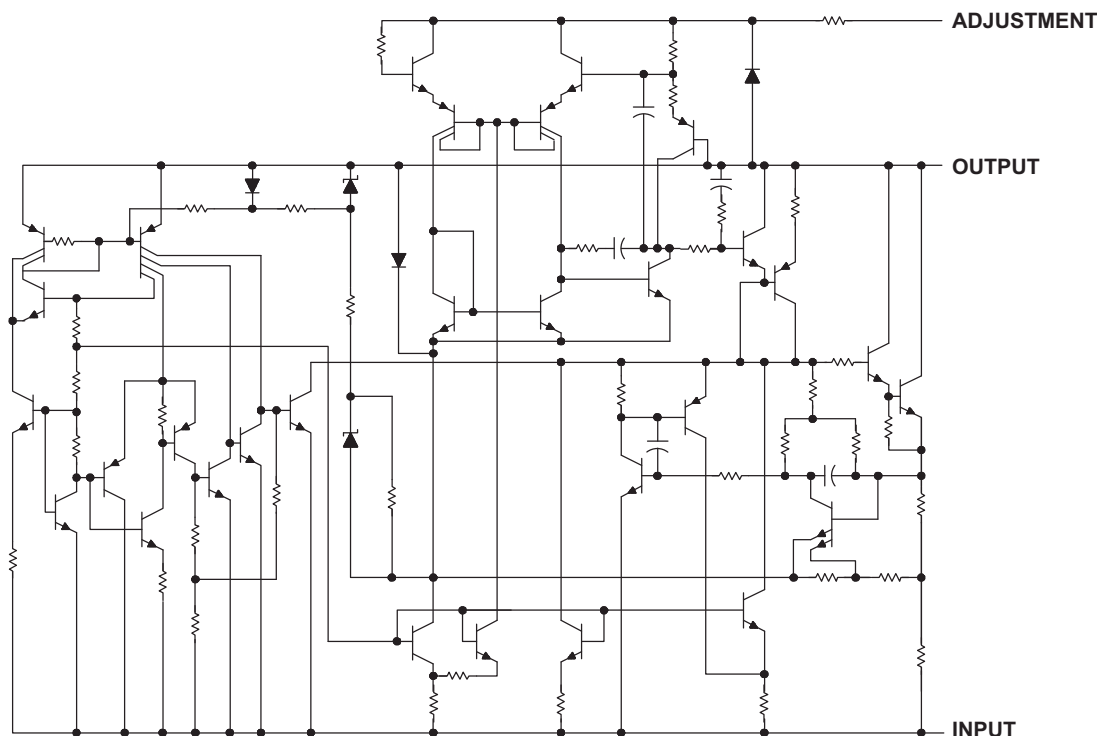

## 8.4 Feature Description

### 8.4.1 Output Voltage Adjustment

The ADJUSTMENT pin serves as a voltage adjustment reference for the output. The ADJUSTMENT pin can be attached to a resistor divider circuit to adjust its own voltage level. The reference voltage  $V_{ADJUSTMENT}$  will typically be 1.25 V higher than  $V_O$ .

## 8.5 Device Functional Modes

### 8.5.1 Adjustable Output Mode

The device has a single functional mode: Adjustable output voltage mode. A resistor divider circuit on the ADJUSTMENT pin determines the output voltage.

## 9 Application and Implementation

### NOTE

Information in the following applications sections is not part of the TI component specification, and TI does not warrant its accuracy or completeness. TI's customers are responsible for determining suitability of components for their purposes. Customers should validate and test their design implementation to confirm system functionality.

### 9.1 Application Information

#### 9.1.1 General Configurations

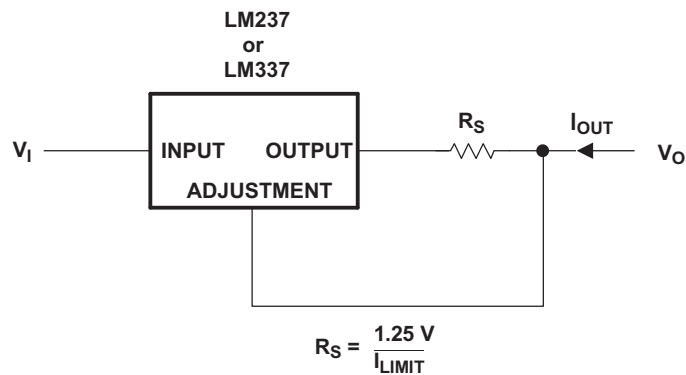

Figure 2. Current-Limiting Circuit

This application uses the LMx37 device's reference voltage, combined with the series resistor  $R_S$ , to limit the current to  $1.25 \text{ V} \div R_S$ .

### 9.2 Typical Application

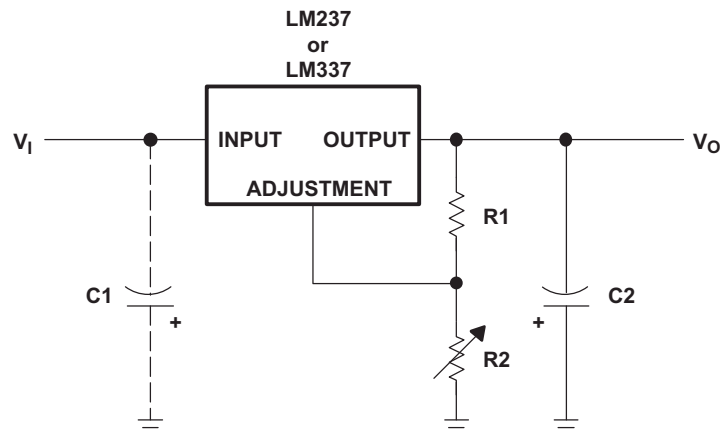

Figure 3. Adjustable Negative-Voltage Regulator

#### 9.2.1 Design Requirements

- 1- $\mu\text{F}$  solid tantalum on the input pin if the regulator is more than 10 cm from the power supply filter capacitor
- 1- $\mu\text{F}$  solid tantalum or 10- $\mu\text{F}$  aluminum electrolytic capacitor is required on the output pin for stability.
- R1, which is usually 120  $\Omega$  as part of the resistor divider.
- R2, which can be varied to change the value of  $V_O$ .

## Typical Application (continued)

### 9.2.2 Detailed Design Procedure

$V_O$  is determined by the values of R1 and R2. Choosing R1 = 120  $\Omega$  means that about 10.42 mA of current will flow through R1. The ~10 mA of current satisfies the minimum operating current and renders  $I_{REF}$  negligible. Since the current is coming from ground, the same amount of current will flow through R2. Therefore, the size of R2 will be the dominant factor in adjusting  $V_O$ . The relationship between R1, R2, and  $V_O$  is as follows:

$$R2 = R1 \left( \frac{V_O}{-1.25} - 1 \right)$$

where  $V_O$  is the output in volts.

(1)

### 9.2.3 Application Curves

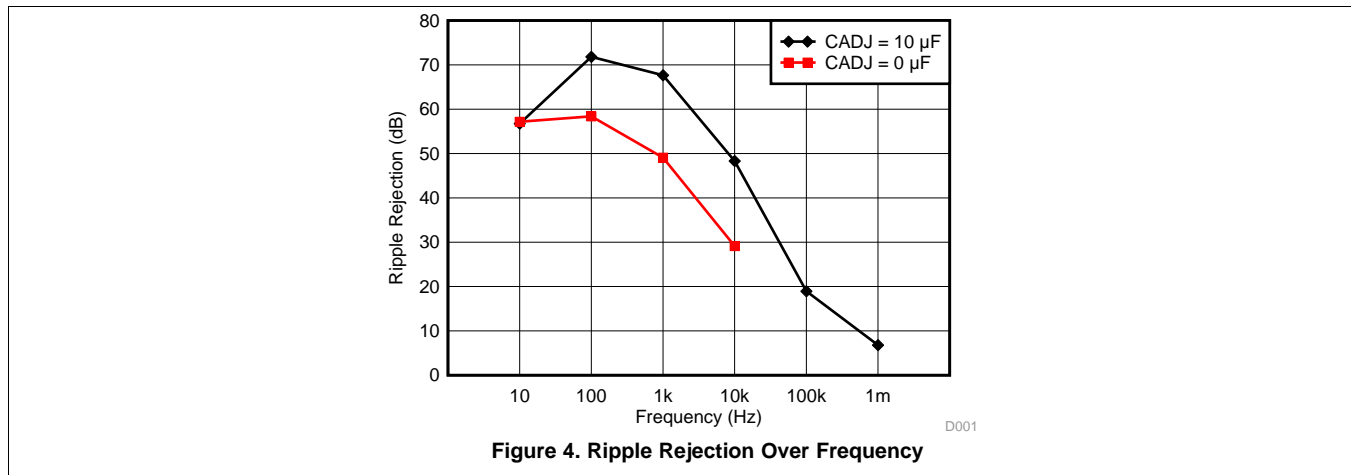

Figure 4. Ripple Rejection Over Frequency

## 10 Power Supply Recommendations

For best performance, the difference in voltage between the output and input must be between -2.5 V and -37 V. A 1- $\mu$ F solid tantalum capacitor is required on the input pin if the regulator is more than 10 cm from the power supply filter capacitor. A 1- $\mu$ F solid tantalum or 10- $\mu$ F aluminum electrolytic capacitor is required on the output pin for stability.

## 11 Layout

### 11.1 Layout Guidelines

Traces on the input and output pins should be thick enough to carry 1.5 A of current without violating thermal requirements of the device or the system. In addition, a 1- $\mu$ F solid tantalum capacitor is required on the input pin if the regulator is more than 10 cm from the power supply filter capacitor. A 1- $\mu$ F solid tantalum or 10- $\mu$ F aluminum electrolytic capacitor is required on the output pin for stability.

### 11.2 Layout Example

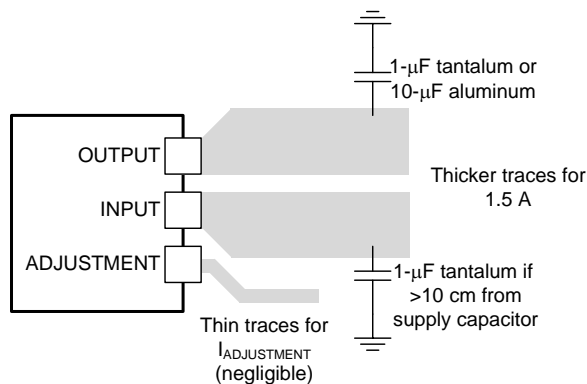

Figure 5. Layout Diagram

## 12 Device and Documentation Support

### 12.1 Related Links

The table below lists quick access links. Categories include technical documents, support and community resources, tools and software, and quick access to sample or buy.

Table 1. Related Links

PARTS	PRODUCT FOLDER	SAMPLE & BUY	TECHNICAL DOCUMENTS	TOOLS & SOFTWARE	SUPPORT & COMMUNITY
LM237	<a href="#">Click here</a>	<a href="#">Click here</a>	<a href="#">Click here</a>	<a href="#">Click here</a>	<a href="#">Click here</a>
LM337	<a href="#">Click here</a>	<a href="#">Click here</a>	<a href="#">Click here</a>	<a href="#">Click here</a>	<a href="#">Click here</a>

### 12.2 Trademarks

### 12.3 Electrostatic Discharge Caution



These devices have limited built-in ESD protection. The leads should be shorted together or the device placed in conductive foam during storage or handling to prevent electrostatic damage to the MOS gates.

### 12.4 Glossary

[SLYZ022](#) — TI Glossary.

This glossary lists and explains terms, acronyms, and definitions.

## 13 Mechanical, Packaging, and Orderable Information

The following pages include mechanical, packaging, and orderable information. This information is the most current data available for the designated devices. This data is subject to change without notice and revision of this document. For browser-based versions of this data sheet, refer to the left-hand navigation.

**PACKAGING INFORMATION**

Orderable Device	Status (1)	Package Type	Package Drawing	Pins	Package Qty	Eco Plan (2)	Lead finish/ Ball material (6)	MSL Peak Temp (3)	Op Temp (°C)	Device Marking (4/5)	Samples
LM237KCSE3	ACTIVE	TO-220	KCS	3	50	RoHS & Green	SN	N / A for Pkg Type	-25 to 150	LM237	<a href="#">Samples</a>
LM337KCSE3	ACTIVE	TO-220	KCS	3	50	RoHS & Green	SN	N / A for Pkg Type	0 to 125	LM337	<a href="#">Samples</a>
LM337KTTR	ACTIVE	DDPAK/ TO-263	KTT	3	500	RoHS & Green	SN	Level-3-245C-168 HR	0 to 125	LM337	<a href="#">Samples</a>
LM337KTTRG3	ACTIVE	DDPAK/ TO-263	KTT	3	500	RoHS & Green	SN	Level-3-245C-168 HR	0 to 125	LM337	<a href="#">Samples</a>
LM337KVURG3	ACTIVE	TO-252	KVU	3	2500	RoHS & Green	SN	Level-3-260C-168 HR	0 to 125	LM337	<a href="#">Samples</a>

(1) The marketing status values are defined as follows:

**ACTIVE:** Product device recommended for new designs.

**LIFEBUY:** TI has announced that the device will be discontinued, and a lifetime-buy period is in effect.

**NRND:** Not recommended for new designs. Device is in production to support existing customers, but TI does not recommend using this part in a new design.

**PREVIEW:** Device has been announced but is not in production. Samples may or may not be available.

**OBSELETE:** TI has discontinued the production of the device.

(2) **RoHS:** TI defines "RoHS" to mean semiconductor products that are compliant with the current EU RoHS requirements for all 10 RoHS substances, including the requirement that RoHS substance do not exceed 0.1% by weight in homogeneous materials. Where designed to be soldered at high temperatures, "RoHS" products are suitable for use in specified lead-free processes. TI may reference these types of products as "Pb-Free".

**RoHS Exempt:** TI defines "RoHS Exempt" to mean products that contain lead but are compliant with EU RoHS pursuant to a specific EU RoHS exemption.

**Green:** TI defines "Green" to mean the content of Chlorine (Cl) and Bromine (Br) based flame retardants meet JS709B low halogen requirements of <=1000ppm threshold. Antimony trioxide based flame retardants must also meet the <=1000ppm threshold requirement.

(3) MSL, Peak Temp. - The Moisture Sensitivity Level rating according to the JEDEC industry standard classifications, and peak solder temperature.

(4) There may be additional marking, which relates to the logo, the lot trace code information, or the environmental category on the device.

(5) Multiple Device Markings will be inside parentheses. Only one Device Marking contained in parentheses and separated by a "~" will appear on a device. If a line is indented then it is a continuation of the previous line and the two combined represent the entire Device Marking for that device.

(6) Lead finish/Ball material - Orderable Devices may have multiple material finish options. Finish options are separated by a vertical ruled line. Lead finish/Ball material values may wrap to two lines if the finish value exceeds the maximum column width.

**Important Information and Disclaimer:** The information provided on this page represents TI's knowledge and belief as of the date that it is provided. TI bases its knowledge and belief on information provided by third parties, and makes no representation or warranty as to the accuracy of such information. Efforts are underway to better integrate information from third parties. TI has taken and continues to take reasonable steps to provide representative and accurate information but may not have conducted destructive testing or chemical analysis on incoming materials and chemicals. TI and TI suppliers consider certain information to be proprietary, and thus CAS numbers and other limited information may not be available for release.

In no event shall TI's liability arising out of such information exceed the total purchase price of the TI part(s) at issue in this document sold by TI to Customer on an annual basis.

**TAPE AND REEL INFORMATION**

**QUADRANT ASSIGNMENTS FOR PIN 1 ORIENTATION IN TAPE**



\*All dimensions are nominal

Device	Package Type	Package Drawing	Pins	SPQ	Reel Diameter (mm)	Reel Width W1 (mm)	A0 (mm)	B0 (mm)	K0 (mm)	P1 (mm)	W (mm)	Pin1 Quadrant
LM337KTTR	DDPAK/ TO-263	KTT	3	500	330.0	24.4	10.8	16.3	5.11	16.0	24.0	Q2
LM337KVURG3	TO-252	KVU	3	2500	330.0	16.4	6.9	10.5	2.7	8.0	16.0	Q2

**TAPE AND REEL BOX DIMENSIONS**

\*All dimensions are nominal

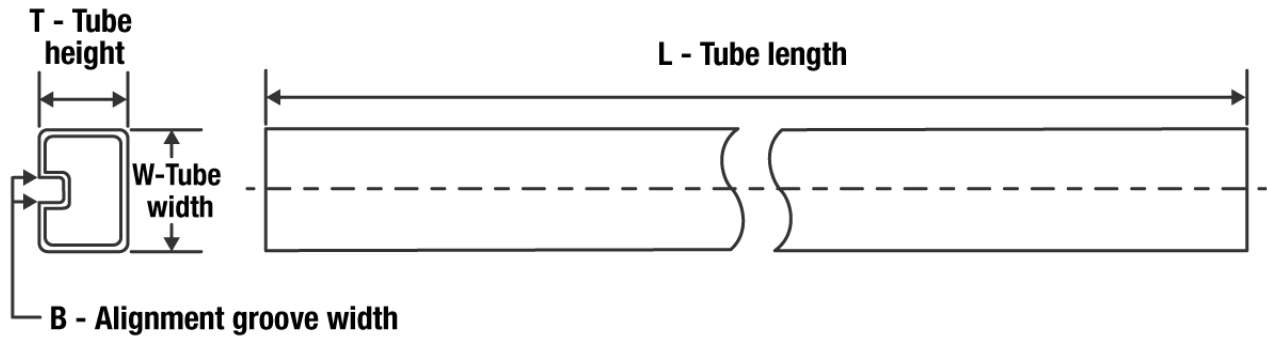
Device	Package Type	Package Drawing	Pins	SPQ	Length (mm)	Width (mm)	Height (mm)
LM337KTTR	DDPAK/TO-263	KTT	3	500	340.0	340.0	38.0
LM337KVURG3	TO-252	KVU	3	2500	340.0	340.0	38.0

**TUBE**

\*All dimensions are nominal

Device	Package Name	Package Type	Pins	SPQ	L (mm)	W (mm)	T (μm)	B (mm)
LM237KCSE3	KCS	TO-220	3	50	532	34.1	700	9.6
LM337KCSE3	KCS	TO-220	3	50	532	34.1	700	9.6

KTT (R-PSFM-G3)

PLASTIC FLANGE-MOUNT PACKAGE

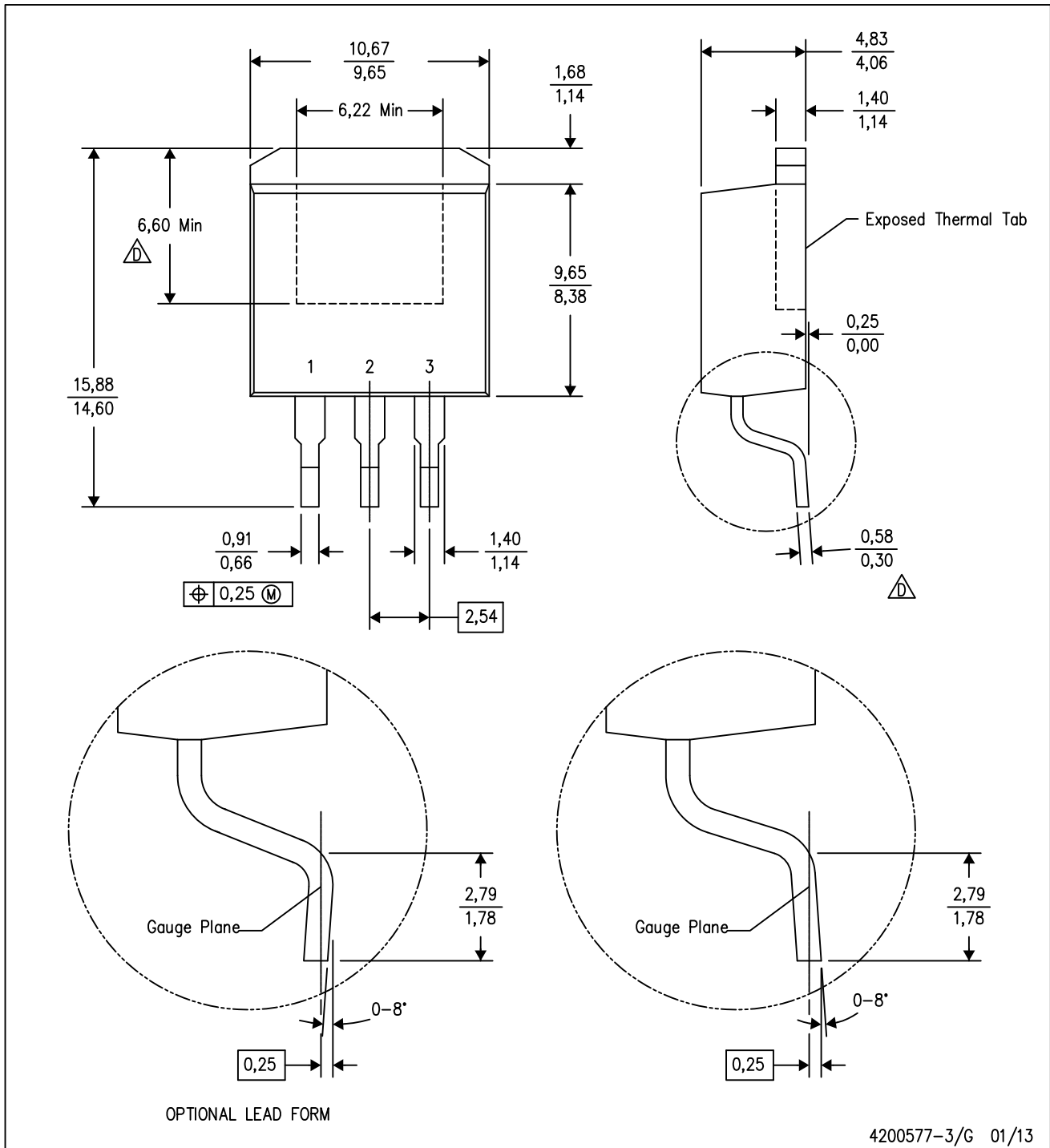

4200577-3/G 01/13

- NOTES:
- A. All linear dimensions are in millimeters.
  - B. This drawing is subject to change without notice.
  - C. Body dimensions do not include mold flash or protrusion. Mold flash or protrusion not to exceed 0.005 (0,13) per side.
-  Falls within JEDEC TO-263 variation AA, except minimum lead thickness and minimum exposed pad length.

KTT (R-PSFM-G3)

PLASTIC FLANGE-MOUNT PACKAGE

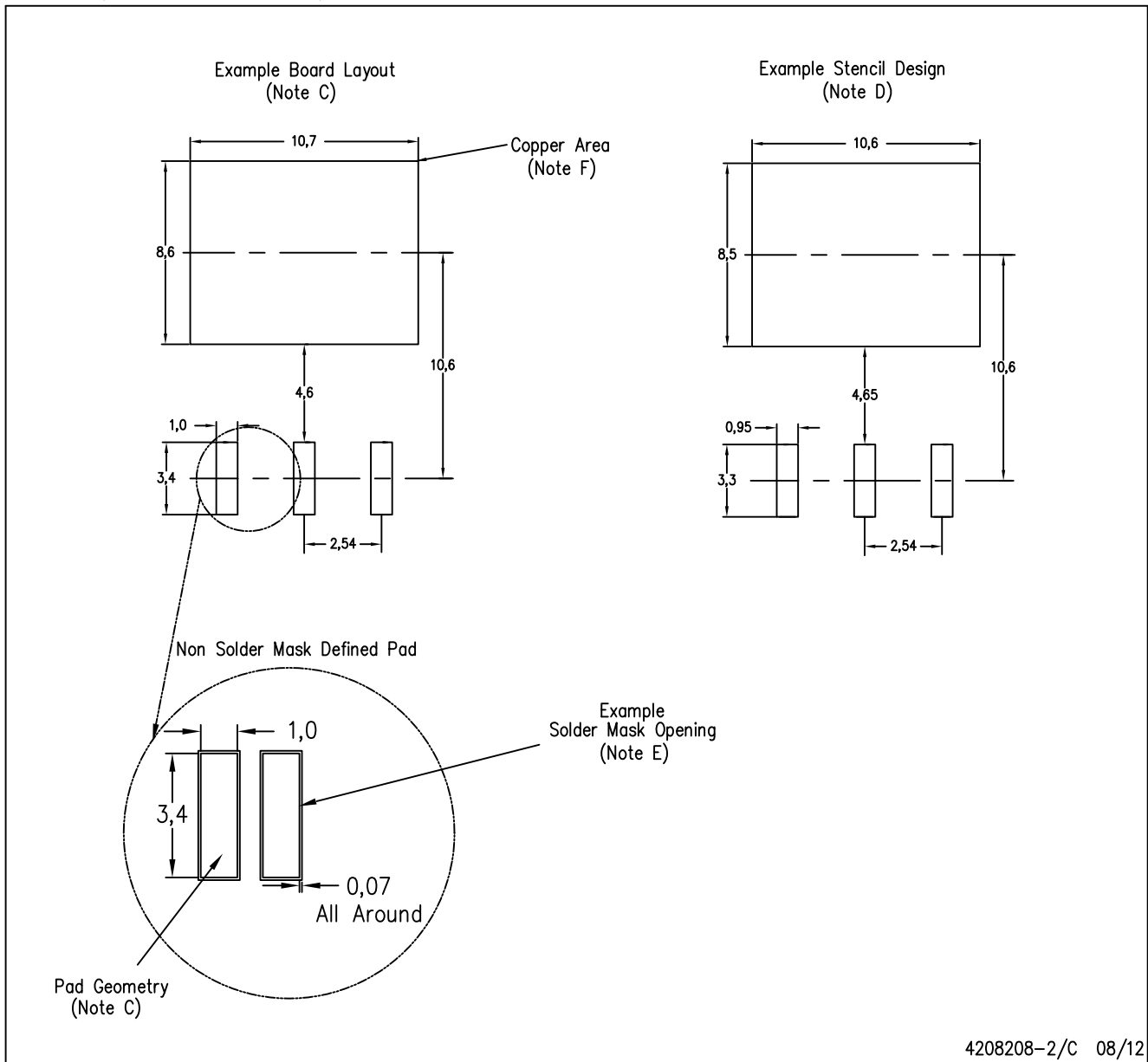

4208208-2/C 08/12

- NOTES:
- All linear dimensions are in millimeters.
  - This drawing is subject to change without notice.
  - Publication IPC-SM-782 is recommended for alternate designs.
  - Laser cutting apertures with trapezoidal walls and also rounding corners will offer better paste release. Customers should contact their board assembly site for stencil design recommendations. Refer to IPC-7525.
  - Customers should contact their board fabrication site for solder mask tolerances between and around signal pads.
  - This package is designed to be soldered to a thermal pad on the board. Refer to the Product Datasheet for specific thermal information, via requirements, and recommended thermal pad size. For thermal pad sizes larger than shown a solder mask defined pad is recommended in order to maintain the solderable pad geometry while increasing copper area.



# EXAMPLE BOARD LAYOUT

KCS0003B

TO-220 - 19.65 mm max height

TO-220

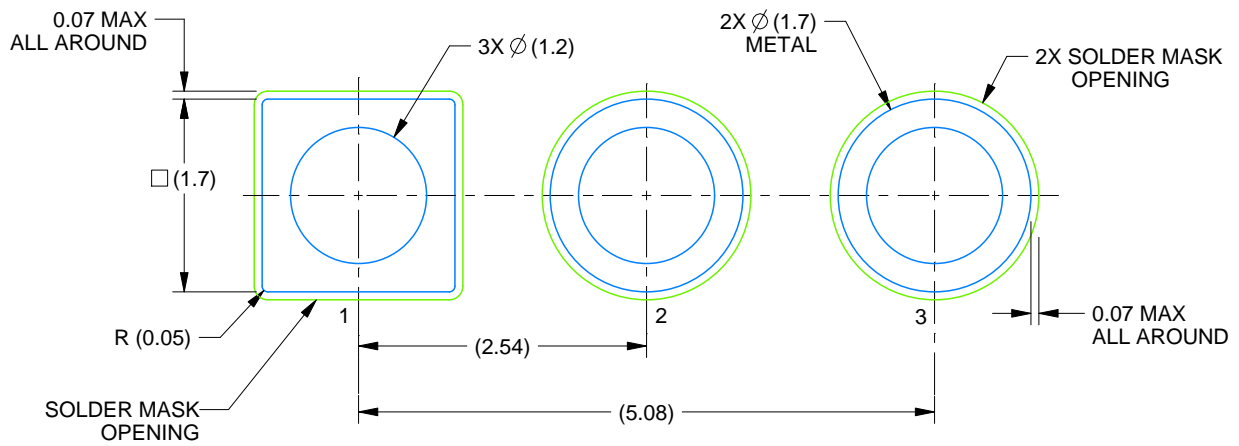

LAND PATTERN EXAMPLE  
NON-SOLDER MASK DEFINED  
SCALE:15X

4222214/B 08/2018

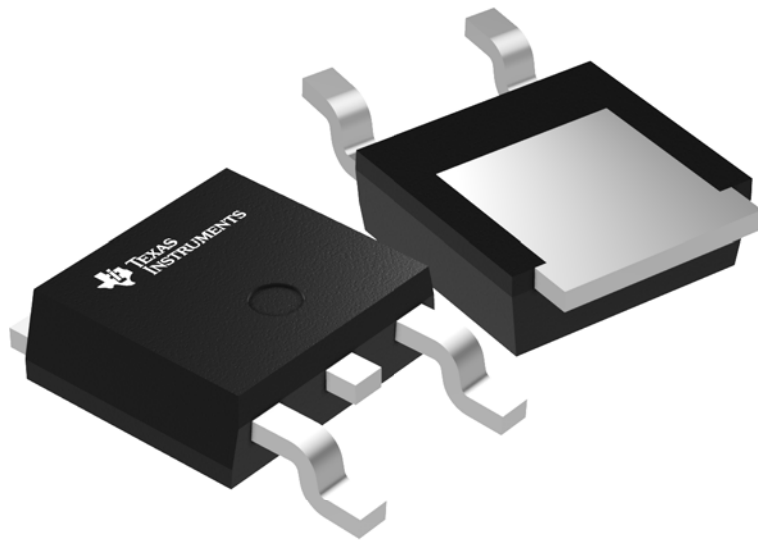

Images above are just a representation of the package family, actual package may vary.  
Refer to the product data sheet for package details.



# EXAMPLE BOARD LAYOUT

KVU0003A

TO-252 - 2.52 mm max height

TO-252

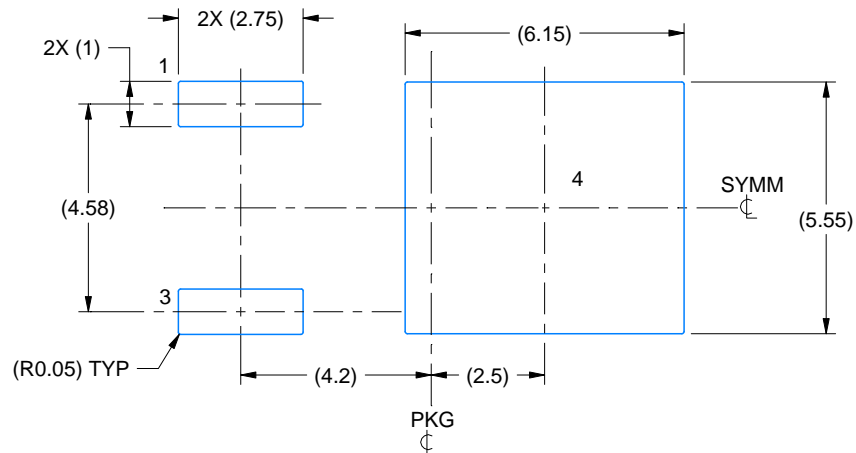

LAND PATTERN EXAMPLE  
EXPOSED METAL SHOWN  
SCALE:6X

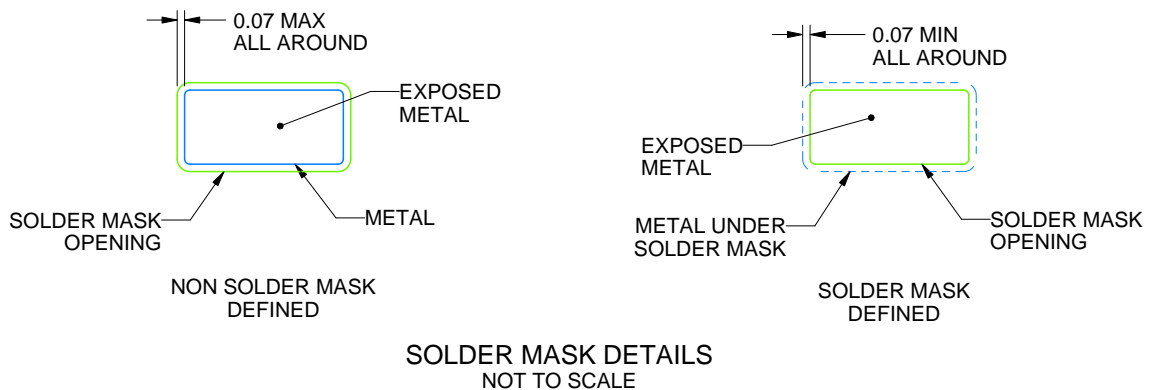

SOLDER MASK DETAILS  
NOT TO SCALE

4218915/A 02/2017

NOTES: (continued)

5. This package is designed to be soldered to a thermal pad on the board. For more information, see Texas Instruments literature numbers SLMA002 ([www.ti.com/lit/slm002](http://www.ti.com/lit/slm002)) and SLMA004 ([www.ti.com/lit/slma004](http://www.ti.com/lit/slma004)).
6. Vias are optional depending on application, refer to device data sheet. It is recommended that vias under paste be filled, plugged or tented.

# EXAMPLE STENCIL DESIGN

KVU0003A

TO-252 - 2.52 mm max height

TO-252

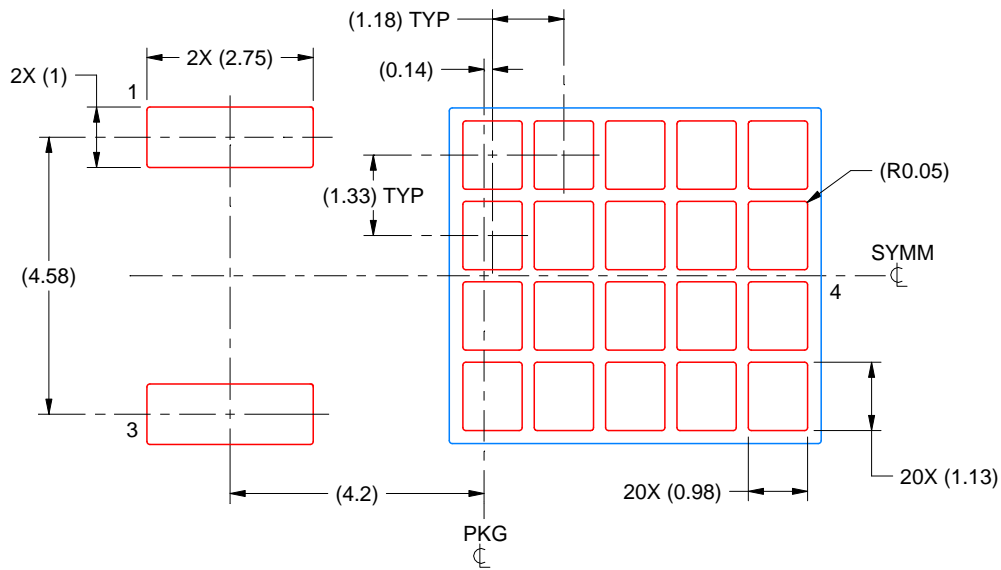

SOLDER PASTE EXAMPLE  
BASED ON 0.125 mm THICK STENCIL

EXPOSED PAD  
65% PRINTED SOLDER COVERAGE BY AREA  
SCALE:8X

4218915/A 02/2017

NOTES: (continued)

7. Laser cutting apertures with trapezoidal walls and rounded corners may offer better paste release. IPC-7525 may have alternate design recommendations.
8. Board assembly site may have different recommendations for stencil design.

## IMPORTANT NOTICE AND DISCLAIMER

TI PROVIDES TECHNICAL AND RELIABILITY DATA (INCLUDING DATA SHEETS), DESIGN RESOURCES (INCLUDING REFERENCE DESIGNS), APPLICATION OR OTHER DESIGN ADVICE, WEB TOOLS, SAFETY INFORMATION, AND OTHER RESOURCES "AS IS" AND WITH ALL FAULTS, AND DISCLAIMS ALL WARRANTIES, EXPRESS AND IMPLIED, INCLUDING WITHOUT LIMITATION ANY IMPLIED WARRANTIES OF MERCHANTABILITY, FITNESS FOR A PARTICULAR PURPOSE OR NON-INFRINGEMENT OF THIRD PARTY INTELLECTUAL PROPERTY RIGHTS.

These resources are intended for skilled developers designing with TI products. You are solely responsible for (1) selecting the appropriate TI products for your application, (2) designing, validating and testing your application, and (3) ensuring your application meets applicable standards, and any other safety, security, regulatory or other requirements.

These resources are subject to change without notice. TI grants you permission to use these resources only for development of an application that uses the TI products described in the resource. Other reproduction and display of these resources is prohibited. No license is granted to any other TI intellectual property right or to any third party intellectual property right. TI disclaims responsibility for, and you will fully indemnify TI and its representatives against, any claims, damages, costs, losses, and liabilities arising out of your use of these resources.

TI's products are provided subject to [TI's Terms of Sale](#) or other applicable terms available either on [ti.com](https://www.ti.com) or provided in conjunction with such TI products. TI's provision of these resources does not expand or otherwise alter TI's applicable warranties or warranty disclaimers for TI products.

TI objects to and rejects any additional or different terms you may have proposed.

Mailing Address: Texas Instruments, Post Office Box 655303, Dallas, Texas 75265  
Copyright © 2024, Texas Instruments Incorporated

## Looking for pricing, stock, or lifecycle information?

Click below to explore more details on WIN SOURCE:

 [View LM337KCSE3](#) on WIN SOURCE

 [Texas Instruments](#) Information

## Optimize Your Supply Chain with WIN SOURCE Solutions

-  Global Sourcing Solution
-  Obsolete Management
-  Cost Control Management
-  Shortage Management
-  Alternative Solution
-  Excess Inventory Management