



THE DATASHEET OF LM337TG



Voltage Regulator - Adjustable Output, Negative

1.5 A

LM337

The LM337 is an adjustable 3-terminal negative voltage regulator capable of supplying in excess of 1.5 A over an output voltage range of -1.2 V to -37 V. This voltage regulator is exceptionally easy to use and requires only two external resistors to set the output voltage. Further, it employs internal current limiting, thermal shutdown and safe area compensation, making it essentially blow-out proof.

The LM337 serves a wide variety of applications including local, on card regulation. This device can also be used to make a programmable output regulator, or by connecting a fixed resistor between the adjustment and output, the LM337 can be used as a precision current regulator.

Features

- Output Current in Excess of 1.5 A
- Output Adjustable between -1.2 V and -37 V
- Internal Thermal Overload Protection
- Internal Short Circuit Current Limiting Constant with Temperature
- Output Transistor Safe-Area Compensation
- Floating Operation for High Voltage Applications
- Eliminates Stocking many Fixed Voltages
- Available in Surface Mount D²PAK and Standard 3-Lead Transistor Package
- These Devices are Pb-Free and are RoHS Compliant

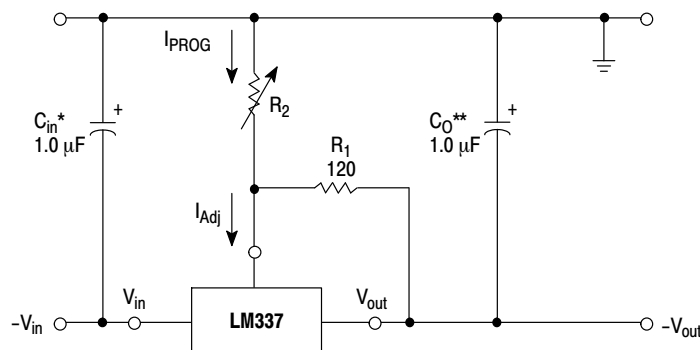

*C_{in} is required if regulator is located more than 4 inches from power supply filter. A 1.0 μF solid tantalum or 10 μF aluminum electrolytic is recommended.

**C_O is necessary for stability. A 1.0 μF solid tantalum or 10 μF aluminum electrolytic is recommended.

$$V_{out} = -1.25 V \left(1 + \frac{R_2}{R_1} \right)$$

Figure 1. Standard Application

THREE-TERMINAL ADJUSTABLE NEGATIVE VOLTAGE REGULATOR

MARKING DIAGRAMS

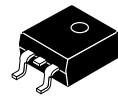

D²PAK
D2T SUFFIX
CASE 936

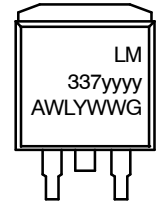

Heatsink surface (shown as terminal 4 in case outline drawing) is connected to Pin 2.

Pin 1. Adjust
2. V_{in}
3. V_{out}

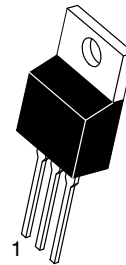

TO-220AB
T SUFFIX
CASE 221AB

Heatsink surface
connected to Pin 2.

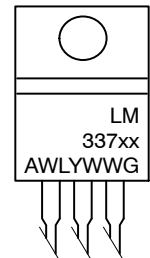

xx = BT, T
yyyy = BD2T, D2T
A = Assembly Location
WL = Wafer Lot
Y = Year
WW = Work Week
G = Pb-Free Package

ORDERING INFORMATION

See detailed ordering and shipping information in the package dimensions section on page 8 of this data sheet.

LM337

MAXIMUM RATINGS ($T_A = +25^\circ\text{C}$, unless otherwise noted)

Rating	Symbol	Value	Unit
Input–Output Voltage Differential	$V_I - V_O$	40	Vdc
Power Dissipation Case 221A $T_A = +25^\circ\text{C}$ Thermal Resistance, Junction–to–Ambient Thermal Resistance, Junction–to–Case Case 936 (D ² PAK) $T_A = +25^\circ\text{C}$ Thermal Resistance, Junction–to–Ambient Thermal Resistance, Junction–to–Case	P_D θ_{JA} θ_{JC} P_D θ_{JA} θ_{JC}	Internally Limited 65 5.0 Internally Limited 70 5.0	W $^\circ\text{C/W}$ $^\circ\text{C/W}$ W $^\circ\text{C/W}$ $^\circ\text{C/W}$
Operating Junction Temperature Range	T_J	–40 to +125	$^\circ\text{C}$
Storage Temperature Range	T_{stg}	–65 to +150	$^\circ\text{C}$

Stresses exceeding those listed in the Maximum Ratings table may damage the device. If any of these limits are exceeded, device functionality should not be assumed, damage may occur and reliability may be affected.

ELECTRICAL CHARACTERISTICS ($|V_I - V_O| = 5.0\text{ V}$; $I_O = 0.5\text{ A}$ for T package; $T_J = T_{low}$ to T_{high} [Note 1]; I_{max} and P_{max} [Note 2].)

Characteristics	Figure	Symbol	Min	Typ	Max	Unit
Line Regulation (Note 3), $T_A = +25^\circ\text{C}$, $3.0\text{ V} \leq V_I - V_O \leq 40\text{ V}$	1	Reg_{line}	–	0.01	0.04	%/V
Load Regulation (Note 3), $T_A = +25^\circ\text{C}$, $10\text{ mA} \leq I_O \leq I_{max}$ $ V_O \leq 5.0\text{ V}$ $ V_O \geq 5.0\text{ V}$	2	Reg_{load}	– –	15 0.3	50 1.0	mV % V_O
Thermal Regulation, $T_A = +25^\circ\text{C}$ (Note 5), 10 ms Pulse		Reg_{therm}	–	0.003	0.04	% V_O /W
Adjustment Pin Current	3	I_{Adj}	–	65	100	μA
Adjustment Pin Current Change, $2.5\text{ V} \leq V_I - V_O \leq 40\text{ V}$, $10\text{ mA} \leq I_L \leq I_{max}$, $P_D \leq P_{max}$, $T_A = +25^\circ\text{C}$	1, 2	ΔI_{Adj}	–	2.0	5.0	μA
Reference Voltage, $T_A = +25^\circ\text{C}$, $3.0\text{ V} \leq V_I - V_O \leq 40\text{ V}$, $10\text{ mA} \leq I_O \leq I_{max}$, $P_D \leq P_{max}$, $T_J = T_{low}$ to T_{high}	3	V_{ref}	–1.213 –1.20	–1.250 –1.25	–1.287 –1.30	V
Line Regulation (Note 3), $3.0\text{ V} \leq V_I - V_O \leq 40\text{ V}$	1	Reg_{line}	–	0.02	0.07	%/V
Load Regulation (Note 3), $10\text{ mA} \leq I_O \leq I_{max}$ $ V_O \leq 5.0\text{ V}$ $ V_O \geq 5.0\text{ V}$	2	Reg_{load}	– –	20 0.3	70 1.5	mV % V_O
Temperature Stability ($T_{low} \leq T_J \leq T_{high}$)	3	T_S	–	0.6	–	% V_O
Minimum Load Current to Maintain Regulation ($ V_I - V_O \leq 10\text{ V}$) ($ V_I - V_O \leq 40\text{ V}$)	3	I_{Lmin}	– –	1.5 2.5	6.0 10	mA
Maximum Output Current $ V_I - V_O \leq 15\text{ V}$, $P_D \leq P_{max}$, T Package $ V_I - V_O \leq 40\text{ V}$, $P_D \leq P_{max}$, $T_J = +25^\circ\text{C}$, T Package	3	I_{max}	– –	1.5 0.15	2.2 0.4	A
RMS Noise, % of V_O , $T_A = +25^\circ\text{C}$, $10\text{ Hz} \leq f \leq 10\text{ kHz}$		N	–	0.003	–	% V_O
Ripple Rejection, $V_O = -10\text{ V}$, $f = 120\text{ Hz}$ (Note 4) Without C_{Adj} $C_{Adj} = 10\text{ }\mu\text{F}$	4	RR	– 66	60 77	– –	dB
Long–Term Stability, $T_J = T_{high}$ (Note 6), $T_A = +25^\circ\text{C}$ for Endpoint Measurements	3	S	–	0.3	1.0	%/1.0 k Hrs.
Thermal Resistance, Junction–to–Case, T Package		$R_{\theta JC}$	–	4.0	–	$^\circ\text{C/W}$

Product parametric performance is indicated in the Electrical Characteristics for the listed test conditions, unless otherwise noted. Product performance may not be indicated by the Electrical Characteristics if operated under different conditions.

- T_{low} to $T_{high} = 0^\circ$ to $+125^\circ\text{C}$, for LM337T, D2T. T_{low} to $T_{high} = -40^\circ$ to $+125^\circ\text{C}$, for LM337BT, BD2T.
- $I_{max} = 1.5\text{ A}$, $P_{max} = 20\text{ W}$
- Load and line regulation are specified at constant junction temperature. Change in V_O because of heating effects is covered under the Thermal Regulation specification. Pulse testing with a low duty cycle is used.
- C_{Adj} , when used, is connected between the adjustment pin and ground.
- Power dissipation within an IC voltage regulator produces a temperature gradient on the die, affecting individual IC components on the die. These effects can be minimized by proper integrated circuit design and layout techniques. Thermal Regulation is the effect of these temperature gradients on the output voltage and is expressed in percentage of output change per watt of power change in a specified time.
- Since Long Term Stability cannot be measured on each device before shipment, this specification is an engineering estimate of average stability from lot to lot.

LM337

Representative Schematic Diagram

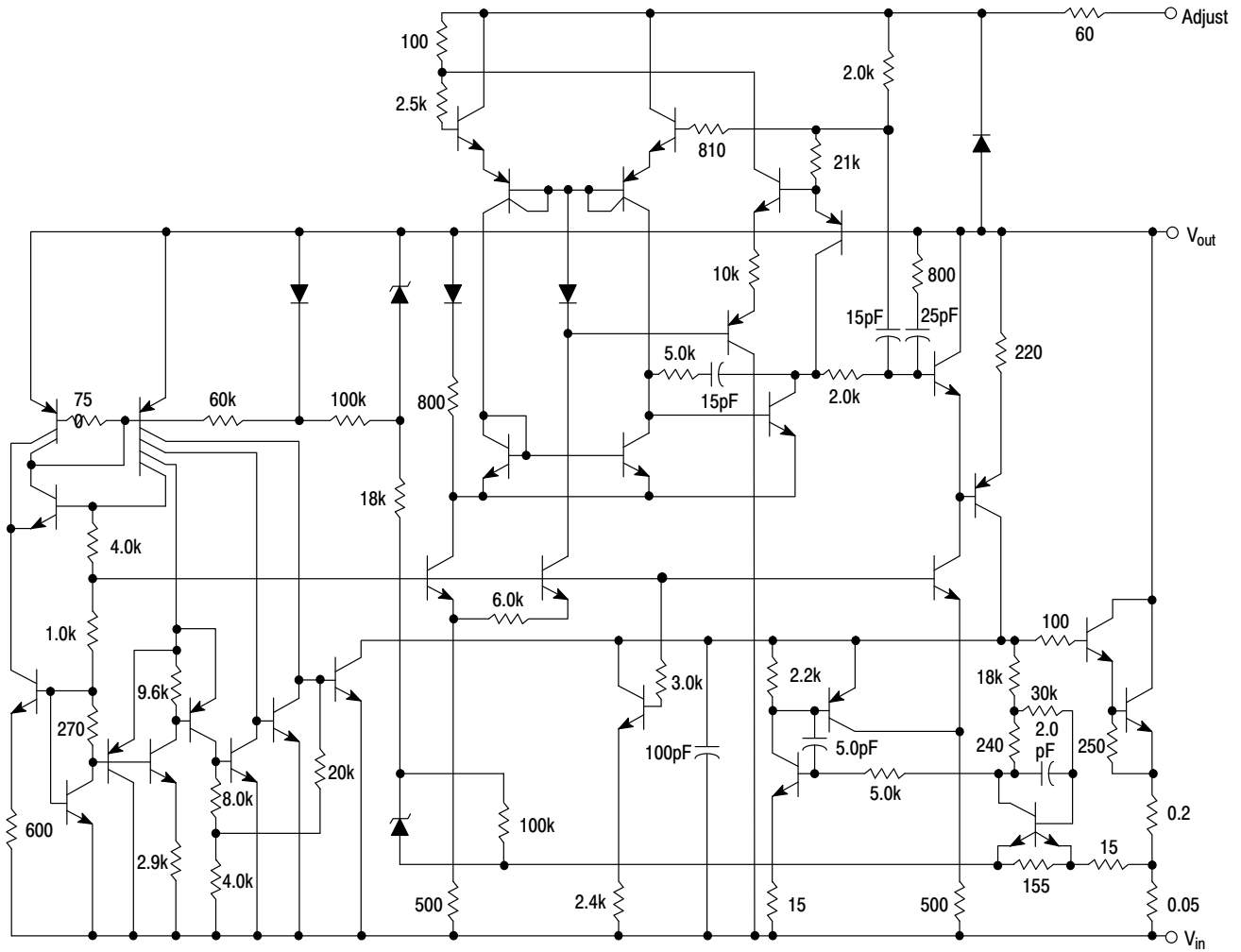

This device contains 39 active transistors.

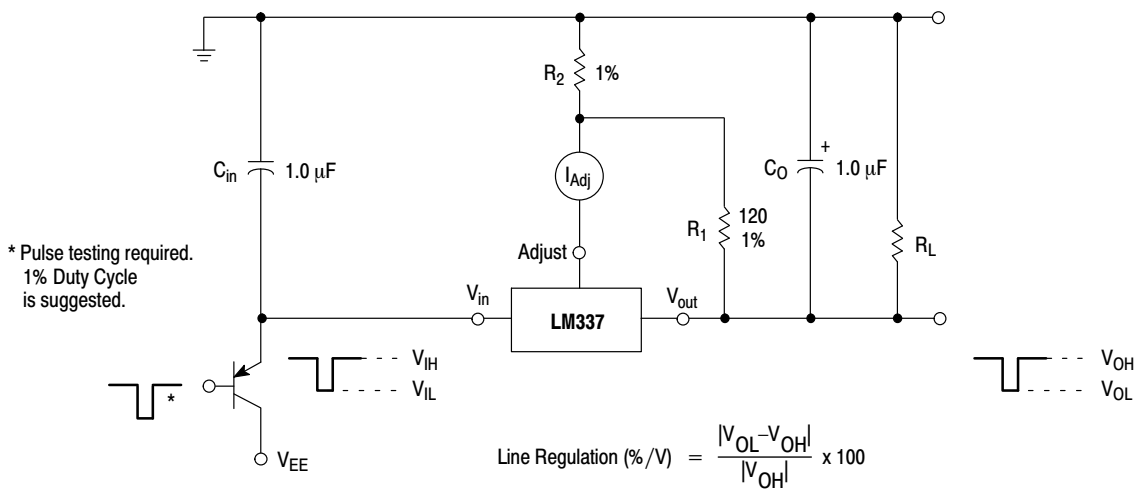

Figure 1. Line Regulation and $\Delta I_{Adj}/\text{Line}$ Test Circuit

LM337

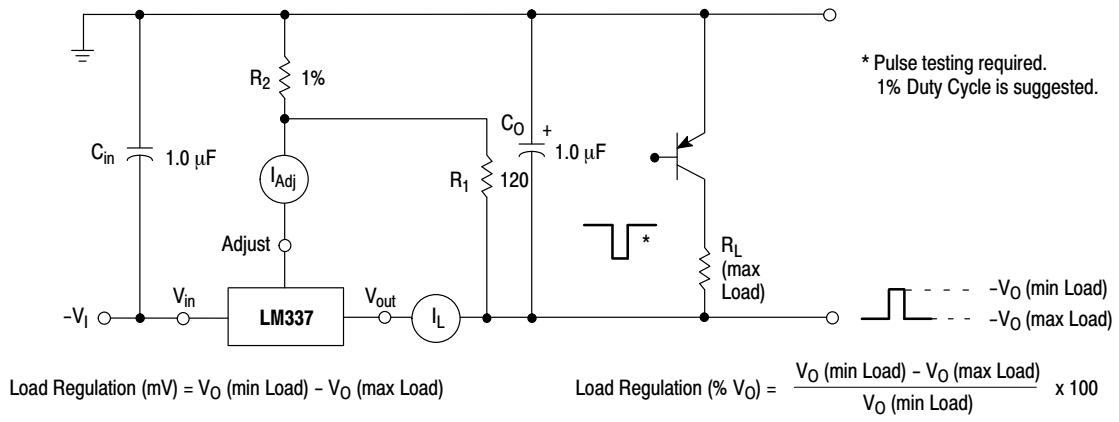

Figure 2. Load Regulation and ΔI_{Adj} /Load Test Circuit

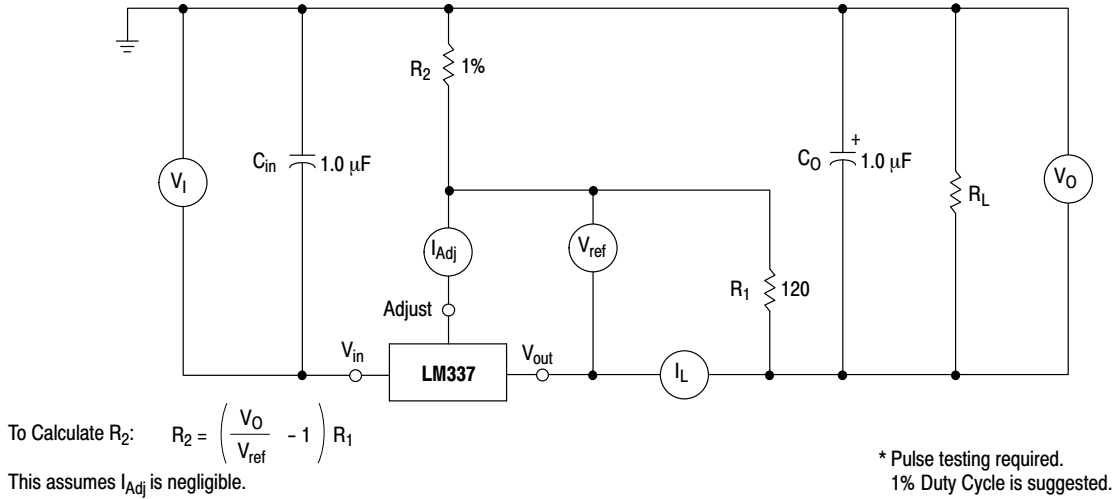

Figure 3. Standard Test Circuit

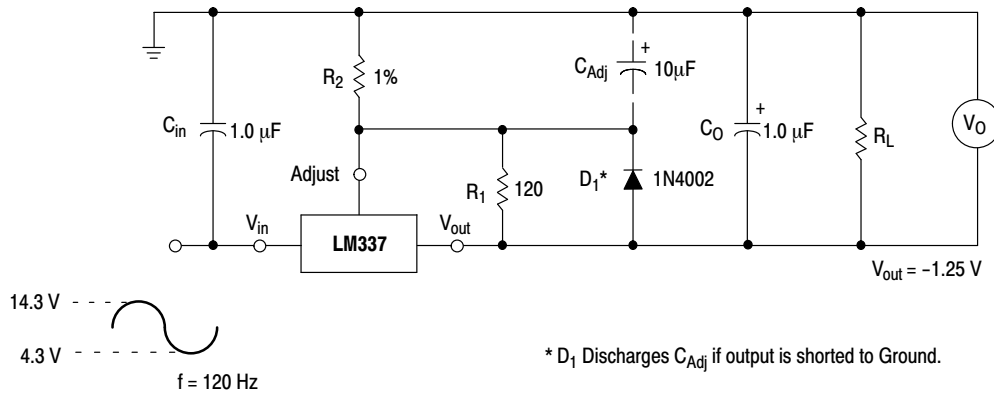

Figure 4. Ripple Rejection Test Circuit

LM337

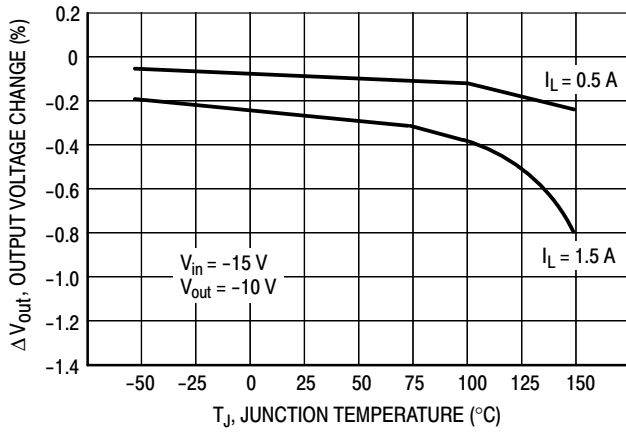

Figure 5. Load Regulation

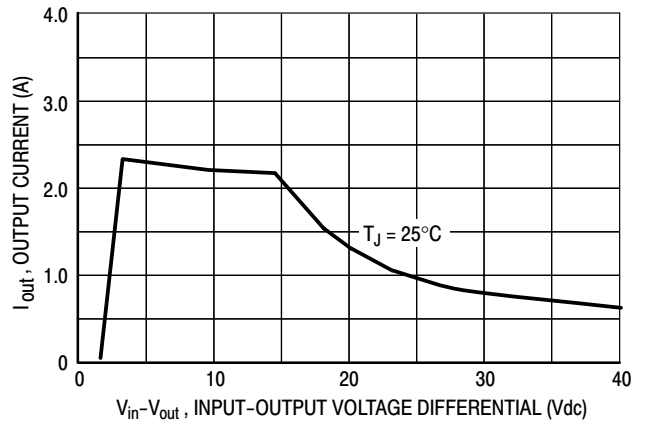

Figure 6. Current Limit

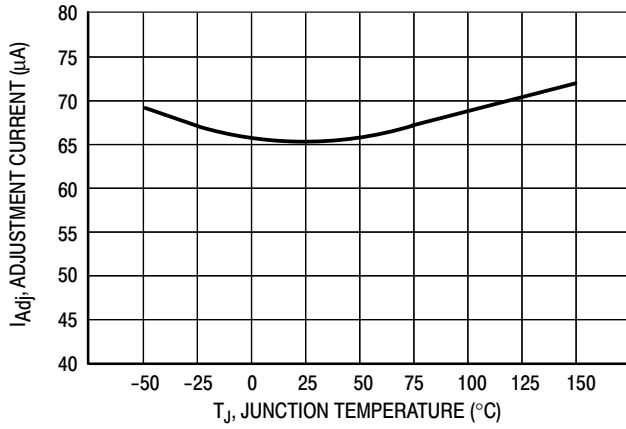

Figure 7. Adjustment Pin Current

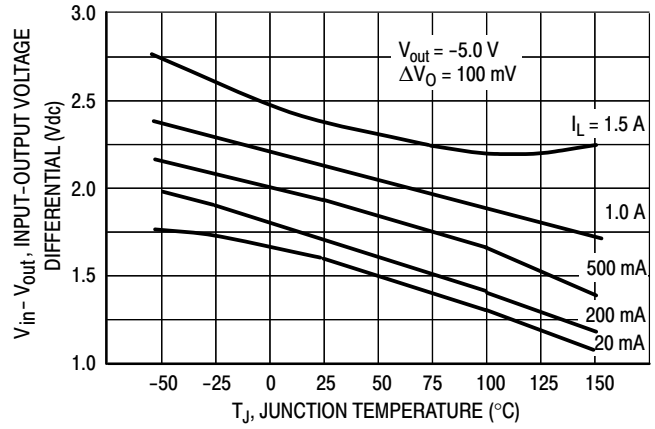

Figure 8. Dropout Voltage

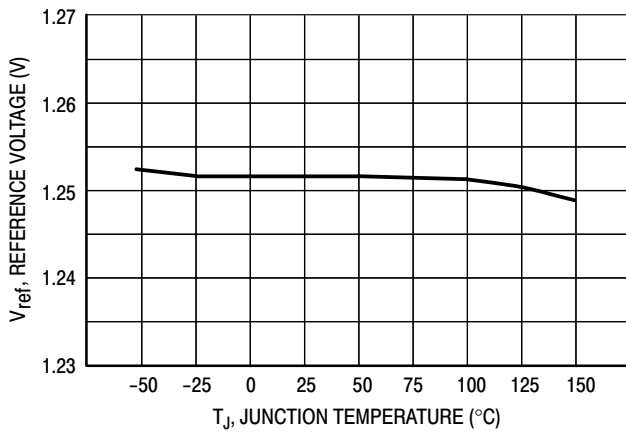

Figure 9. Temperature Stability

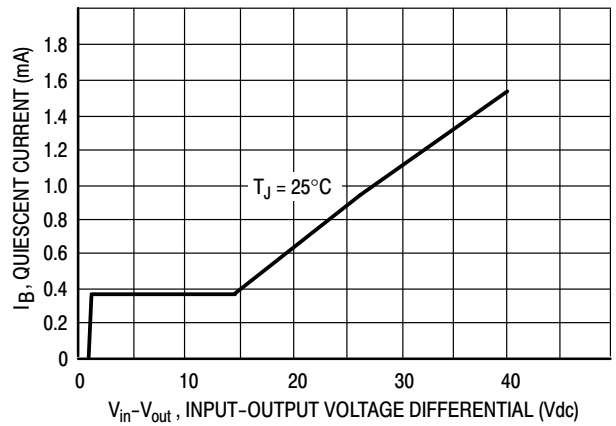

Figure 10. Minimum Operating Current

LM337

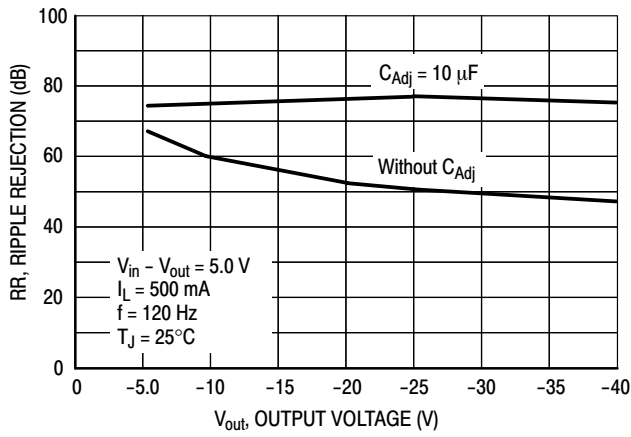

Figure 11. Ripple Rejection versus Output Voltage

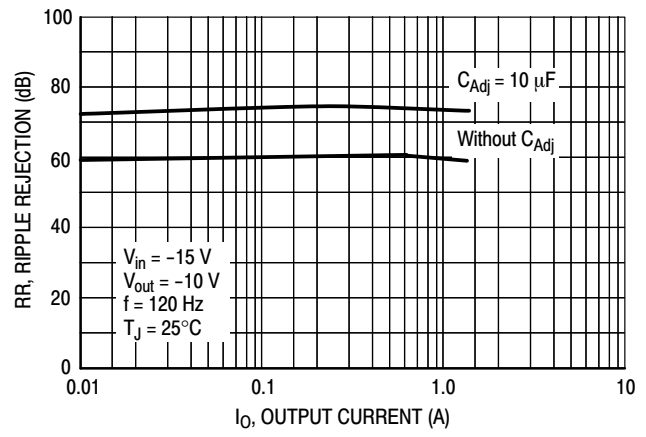

Figure 12. Ripple Rejection versus Output Current

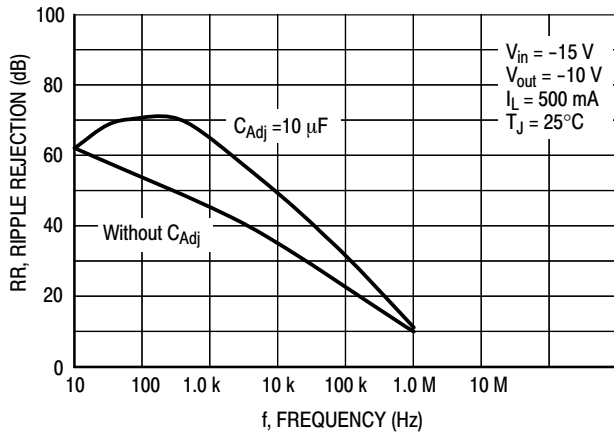

Figure 13. Ripple Rejection versus Frequency

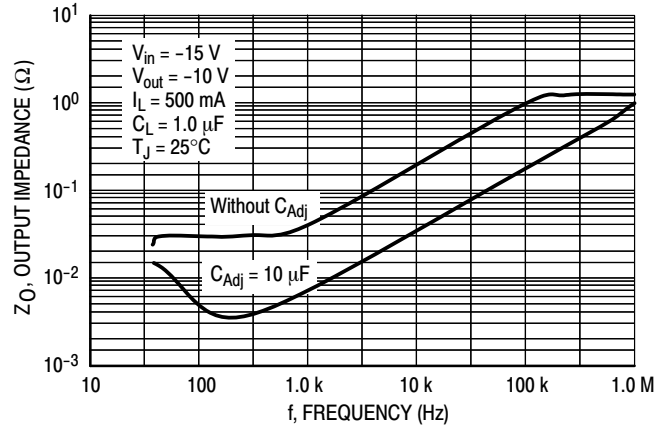

Figure 14. Output Impedance

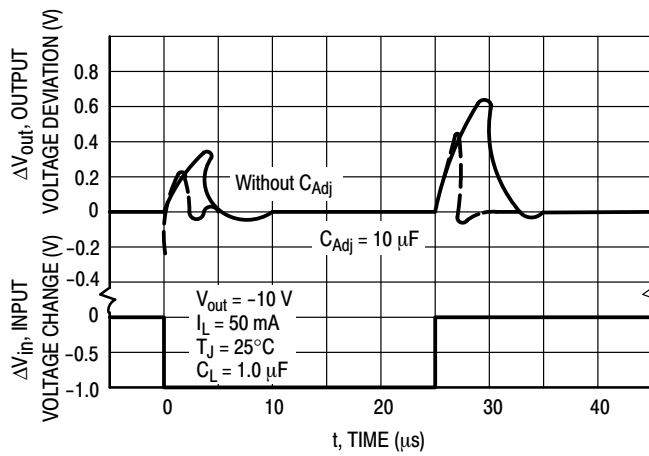

Figure 15. Line Transient Response

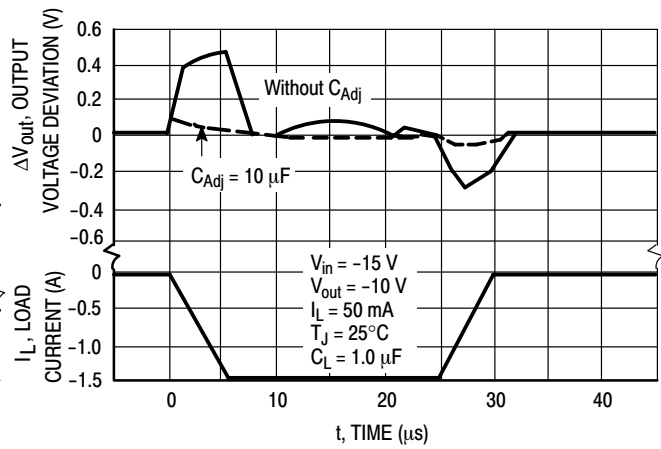

Figure 16. Load Transient Response

APPLICATIONS INFORMATION

Basic Circuit Operation

The LM337 is a 3-terminal floating regulator. In operation, the LM337 develops and maintains a nominal -1.25 V reference (V_{ref}) between its output and adjustment terminals. This reference voltage is converted to a programming current (I_{PROG}) by R_1 (see Figure 17), and this constant current flows through R_2 from ground.

The regulated output voltage is given by:

$$V_{\text{out}} = V_{\text{ref}} \left(1 + \frac{R_2}{R_1} \right) + I_{\text{Adj}} R_2$$

Since the current into the adjustment terminal (I_{Adj}) represents an error term in the equation, the LM337 was designed to control I_{Adj} to less than $100\text{ }\mu\text{A}$ and keep it constant. To do this, all quiescent operating current is returned to the output terminal. This imposes the requirement for a minimum load current. If the load current is less than this minimum, the output voltage will rise.

Since the LM337 is a floating regulator, it is only the voltage differential across the circuit which is important to performance, and operation at high voltages with respect to ground is possible.

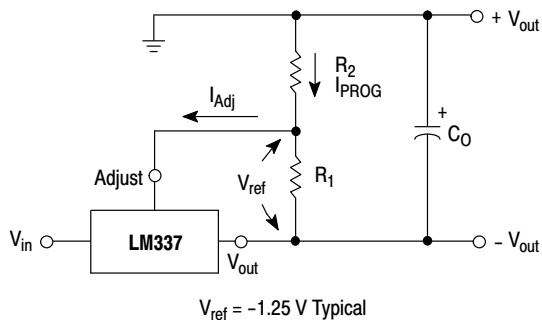

Figure 17. Basic Circuit Configuration

Load Regulation

The LM337 is capable of providing extremely good load regulation, but a few precautions are needed to obtain maximum performance. For best performance, the programming resistor (R_1) should be connected as close to the regulator as possible to minimize line drops which effectively appear in series with the reference, thereby degrading regulation. The ground end of R_2 can be returned near the load ground to provide remote ground sensing and improve load regulation.

External Capacitors

A $1.0\text{ }\mu\text{F}$ tantalum input bypass capacitor (C_{in}) is recommended to reduce the sensitivity to input line impedance.

The adjustment terminal may be bypassed to ground to improve ripple rejection. This capacitor (C_{Adj}) prevents ripple from being amplified as the output voltage is increased. A $10\text{ }\mu\text{F}$ capacitor should improve ripple rejection about 15 dB at 120 Hz in a 10 V application.

An output capacitance (C_O) in the form of a $1.0\text{ }\mu\text{F}$ tantalum or $10\text{ }\mu\text{F}$ aluminum electrolytic capacitor is required for stability. Using the classical tantalum or aluminum electrolytic capacitor types with non-reduced ESR (Equivalent Series Resistance) value is necessary. Low-ESR or similar capacitor types with reduced ESR value and ceramic capacitors can cause instability or continuous oscillations in the application.

Protection Diodes

When external capacitors are used with any IC regulator it is sometimes necessary to add protection diodes to prevent the capacitors from discharging through low current points into the regulator.

Figure 18 shows the LM337 with the recommended protection diodes for output voltages in excess of -25 V or high capacitance values ($C_O > 25\text{ }\mu\text{F}$, $C_{\text{Adj}} > 10\text{ }\mu\text{F}$). Diode D_1 prevents C_O from discharging thru the IC during an input short circuit. Diode D_2 protects against capacitor C_{Adj} discharging through the IC during an output short circuit. The combination of diodes D_1 and D_2 prevents C_{Adj} from the discharging through the IC during an input short circuit.

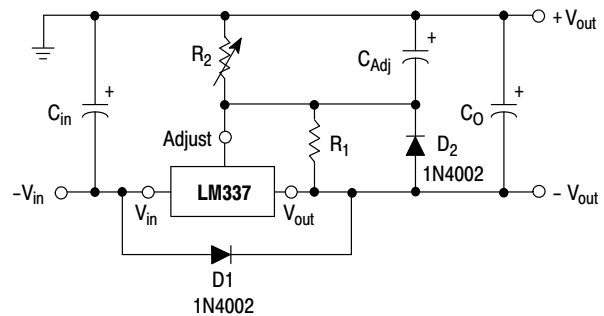

Figure 18. Voltage Regulator with Protection Diodes

LM337

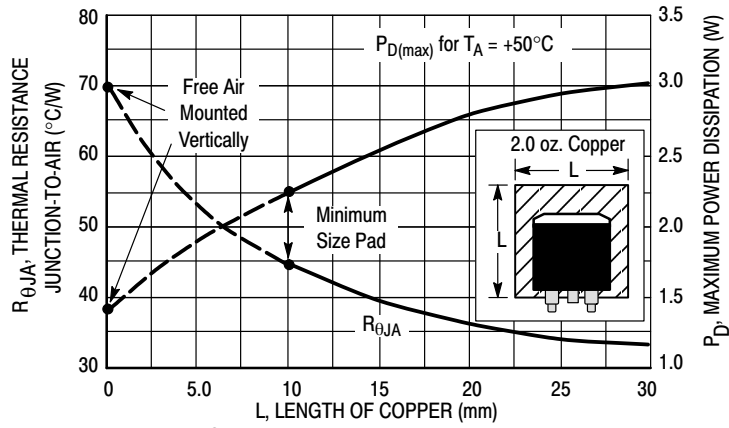

Figure 19. D²PAK Thermal Resistance and Maximum Power Dissipation versus P.C.B. Copper Length

ORDERING INFORMATION

Device	Operating Temperature Range	Package	Shipping [†]
LM337BD2TR4G	$T_J = -40^{\circ}$ to $+125^{\circ}\text{C}$	D ² PAK (Pb-Free)	800 / Tape & Reel
LM337BTG		TO-220AB (Pb-Free)	50 Units / Rail
LM337D2TR4G	$T_J = 0^{\circ}$ to $+125^{\circ}\text{C}$	D ² PAK (Pb-Free)	800 / Tape & Reel
LM337TG		TO-220AB (Pb-Free)	50 Units / Rail

[†]For information on tape and reel specifications, including part orientation and tape sizes, please refer to our Tape and Reel Packaging Specifications Brochure, BRD8011/D.

MECHANICAL CASE OUTLINE

PACKAGE DIMENSIONS

ON Semiconductor®



TO-220, SINGLE GAUGE CASE 221AB-01 ISSUE A

DATE 16 NOV 2010

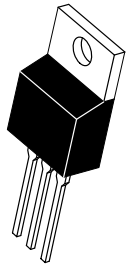

SCALE 1:1

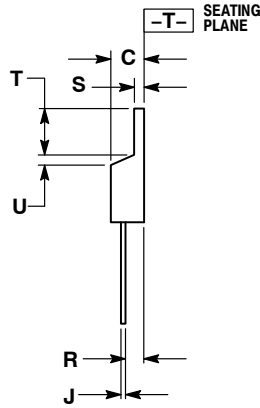
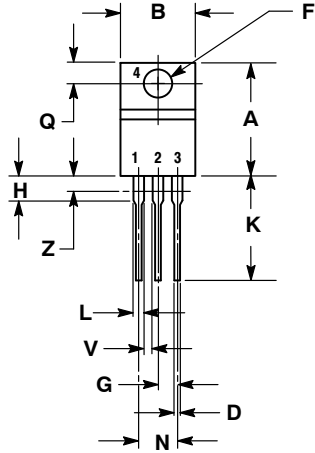

NOTES:

1. DIMENSIONING AND TOLERANCING PER ANSI Y14.5M, 1982.
2. CONTROLLING DIMENSION: INCHES.
3. DIMENSION Z DEFINES A ZONE WHERE ALL BODY AND LEAD IRREGULARITIES ARE ALLOWED.
4. PRODUCT SHIPPED PRIOR TO 2008 HAD DIMENSIONS S = 0.045 - 0.055 INCHES (1.143 - 1.397 MM)

DIM	INCHES		MILLIMETERS	
	MIN	MAX	MIN	MAX
A	0.570	0.620	14.48	15.75
B	0.380	0.405	9.66	10.28
C	0.160	0.190	4.07	4.82
D	0.025	0.035	0.64	0.88
F	0.142	0.147	3.61	3.73
G	0.095	0.105	2.42	2.66
H	0.110	0.155	2.80	3.93
J	0.018	0.025	0.46	0.64
K	0.500	0.562	12.70	14.27
L	0.045	0.060	1.15	1.52
N	0.190	0.210	4.83	5.33
Q	0.100	0.120	2.54	3.04
R	0.080	0.110	2.04	2.79
S	0.020	0.024	0.508	0.61
T	0.235	0.255	5.97	6.47
U	0.000	0.050	0.00	1.27
V	0.045	---	1.15	---
Z	---	0.080	---	2.04

STYLE 1:

- PIN 1. BASE
2. COLLECTOR
3. EMITTER
4. COLLECTOR

STYLE 2:

- PIN 1. BASE
2. EMITTER
3. COLLECTOR
4. EMITTER

STYLE 3:

- PIN 1. CATHODE
2. ANODE
3. GATE
4. ANODE

STYLE 4:

- PIN 1. MAIN TERMINAL 1
2. MAIN TERMINAL 2
3. GATE
4. MAIN TERMINAL 2

STYLE 5:

- PIN 1. GATE
2. DRAIN
3. SOURCE
4. DRAIN

STYLE 6:

- PIN 1. ANODE
2. CATHODE
3. ANODE
4. CATHODE

STYLE 7:

- PIN 1. CATHODE
2. ANODE
3. CATHODE
4. ANODE

STYLE 8:

- PIN 1. CATHODE
2. ANODE
3. EXTERNAL TRIP/DELAY
4. ANODE

STYLE 9:

- PIN 1. GATE
2. COLLECTOR
3. EMITTER
4. COLLECTOR

STYLE 10:

- PIN 1. GATE
2. SOURCE
3. DRAIN
4. SOURCE

STYLE 11:

- PIN 1. DRAIN
2. SOURCE
3. GATE
4. SOURCE

DOCUMENT NUMBER:	98AON23085D	Electronic versions are uncontrolled except when accessed directly from the Document Repository. Printed versions are uncontrolled except when stamped "CONTROLLED COPY" in red.
DESCRIPTION:	TO-220, SINGLE GAUGE	PAGE 1 OF 1

ON Semiconductor and are trademarks of Semiconductor Components Industries, LLC dba ON Semiconductor or its subsidiaries in the United States and/or other countries. ON Semiconductor reserves the right to make changes without further notice to any products herein. ON Semiconductor makes no warranty, representation or guarantee regarding the suitability of its products for any particular purpose, nor does ON Semiconductor assume any liability arising out of the application or use of any product or circuit, and specifically disclaims any and all liability, including without limitation special, consequential or incidental damages. ON Semiconductor does not convey any license under its patent rights nor the rights of others.

MECHANICAL CASE OUTLINE

PACKAGE DIMENSIONS

ON Semiconductor®

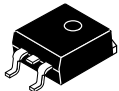

SCALE 1:1

D²PAK
CASE 936-03
ISSUE E

DATE 29 SEP 2015

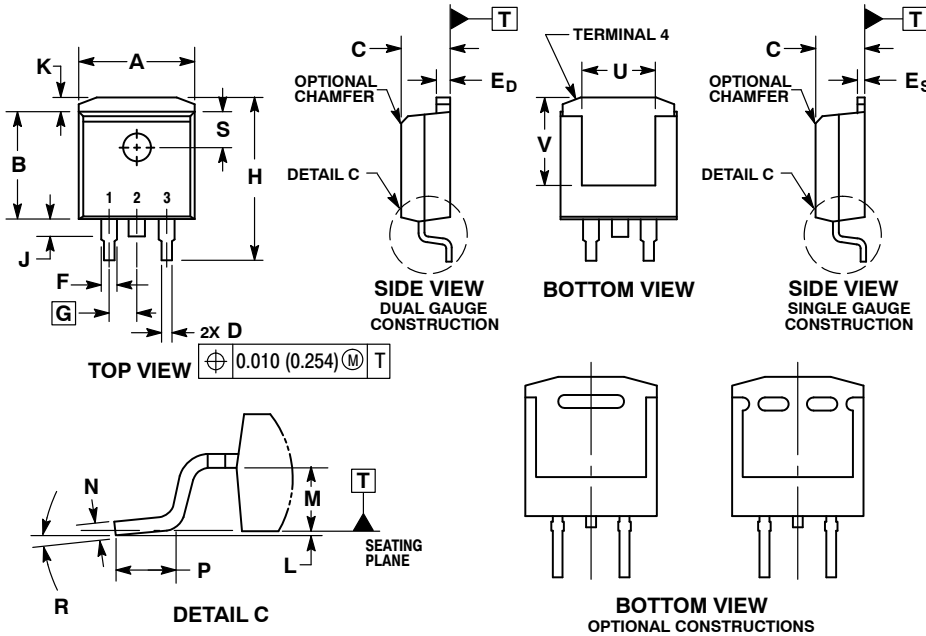

NOTES:

1. DIMENSIONING AND TOLERANCING PER ANSI Y14.5M, 1982.
2. CONTROLLING DIMENSION: INCHES.
3. TAB CONTOUR OPTIONAL WITHIN DIMENSIONS A AND K.
4. DIMENSIONS U AND V ESTABLISH A MINIMUM MOUNTING SURFACE FOR TERMINAL 4.
5. DIMENSIONS A AND B DO NOT INCLUDE MOLD FLASH OR GATE PROTRUSIONS. MOLD FLASH AND GATE PROTRUSIONS NOT TO EXCEED 0.025 (0.635) MAXIMUM.
6. SINGLE GAUGE DESIGN WILL BE SHIPPED AFTER FPCN EXPIRATION IN OCTOBER 2011.

DIM	INCHES		MILLIMETERS	
	MIN	MAX	MIN	MAX
A	0.386	0.403	9.804	10.236
B	0.356	0.368	9.042	9.347
C	0.170	0.180	4.318	4.572
D	0.026	0.036	0.660	0.914
E _D	0.045	0.055	1.143	1.397
E _S	0.018	0.026	0.457	0.660
F	0.051 REF		1.295 REF	
G	0.100 BSC		2.540 BSC	
H	0.539	0.579	13.691	14.707
J	0.125 MAX		3.175 MAX	
K	0.050 REF		1.270 REF	
L	0.000	0.010	0.000	0.254
M	0.088	0.102	2.235	2.591
N	0.018	0.026	0.457	0.660
P	0.058	0.078	1.473	1.981
R	0°	8°	0°	8°
S	0.116 REF		2.946 REF	
U	0.200 MIN		5.080 MIN	
V	0.250 MIN		6.350 MIN	

SOLDERING FOOTPRINT*

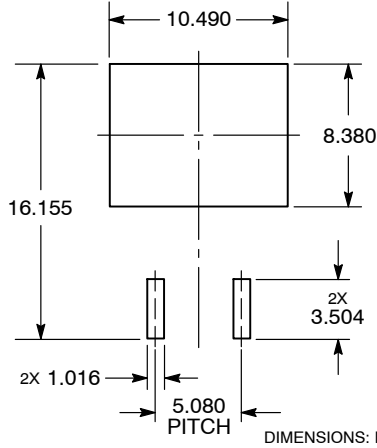

*For additional information on our Pb-Free strategy and soldering details, please download the ON Semiconductor Soldering and Mounting Techniques Reference Manual, SOLDERRM/D.

GENERIC MARKING DIAGRAM*



- XXXXXX = Specific Device Code
- A = Assembly Location
- L = Wafer Lot
- Y = Year
- WW = Work Week
- G = Pb-Free Package

*This information is generic. Please refer to device data sheet for actual part marking. Pb-Free indicator, "G" or microdot "▪", may or may not be present.

DOCUMENT NUMBER:	98ASH01005A	Electronic versions are uncontrolled except when accessed directly from the Document Repository. Printed versions are uncontrolled except when stamped "CONTROLLED COPY" in red.
DESCRIPTION:	D²PAK	PAGE 1 OF 1

ON Semiconductor and are trademarks of Semiconductor Components Industries, LLC dba ON Semiconductor or its subsidiaries in the United States and/or other countries. ON Semiconductor reserves the right to make changes without further notice to any products herein. ON Semiconductor makes no warranty, representation or guarantee regarding the suitability of its products for any particular purpose, nor does ON Semiconductor assume any liability arising out of the application or use of any product or circuit, and specifically disclaims any and all liability, including without limitation special, consequential or incidental damages. ON Semiconductor does not convey any license under its patent rights nor the rights of others.

onsemi, **Onsemi**, and other names, marks, and brands are registered and/or common law trademarks of Semiconductor Components Industries, LLC dba "**onsemi**" or its affiliates and/or subsidiaries in the United States and/or other countries. **onsemi** owns the rights to a number of patents, trademarks, copyrights, trade secrets, and other intellectual property. A listing of **onsemi**'s product/patent coverage may be accessed at www.onsemi.com/site/pdf/Patent-Marking.pdf. **onsemi** reserves the right to make changes at any time to any products or information herein, without notice. The information herein is provided "as-is" and **onsemi** makes no warranty, representation or guarantee regarding the accuracy of the information, product features, availability, functionality, or suitability of its products for any particular purpose, nor does **onsemi** assume any liability arising out of the application or use of any product or circuit, and specifically disclaims any and all liability, including without limitation special, consequential or incidental damages. Buyer is responsible for its products and applications using **onsemi** products, including compliance with all laws, regulations and safety requirements or standards, regardless of any support or applications information provided by **onsemi**. "Typical" parameters which may be provided in **onsemi** data sheets and/or specifications can and do vary in different applications and actual performance may vary over time. All operating parameters, including "Typicals" must be validated for each customer application by customer's technical experts. **onsemi** does not convey any license under any of its intellectual property rights nor the rights of others. **onsemi** products are not designed, intended, or authorized for use as a critical component in life support systems or any FDA Class 3 medical devices or medical devices with a same or similar classification in a foreign jurisdiction or any devices intended for implantation in the human body. Should Buyer purchase or use **onsemi** products for any such unintended or unauthorized application, Buyer shall indemnify and hold **onsemi** and its officers, employees, subsidiaries, affiliates, and distributors harmless against all claims, costs, damages, and expenses, and reasonable attorney fees arising out of, directly or indirectly, any claim of personal injury or death associated with such unintended or unauthorized use, even if such claim alleges that **onsemi** was negligent regarding the design or manufacture of the part. **onsemi** is an Equal Opportunity/Affirmative Action Employer. This literature is subject to all applicable copyright laws and is not for resale in any manner.

ADDITIONAL INFORMATION

TECHNICAL PUBLICATIONS:

Technical Library: www.onsemi.com/design/resources/technical-documentation
onsemi Website: www.onsemi.com

ONLINE SUPPORT: www.onsemi.com/support

For additional information, please contact your local Sales Representative at www.onsemi.com/support/sales

Looking for pricing, stock, or lifecycle information?

Click below to explore more details on WIN SOURCE:

 [View LM337TG on WIN SOURCE](#)

 [ON Semiconductor](#) Information

Optimize Your Supply Chain with WIN SOURCE Solutions

-  Global Sourcing Solution
-  Obsolete Management
-  Cost Control Management
-  Shortage Management
-  Alternative Solution
-  Excess Inventory Management