



**THE DATASHEET OF
LM3406HVMHX/NOPB**



LM3406 1.5-A, Constant Current, Buck Regulator for Driving High Power LEDs

1 FEATURES

- LM3406HV-Q1
 - Automotive Grade Device
 - AEC-Q100 Grade 1 Qualified
 - Operating Ambient Temperature: -40°C to 125°C
- Integrated 2.0A MOSFET
- V_{IN} Range 6V to 42V (LM3406)
- V_{IN} Range 6V to 75V (LM3406HV)
- V_{IN} Range 6V to 75V (LM3406HV-Q1)
- True Average Output Current Control
- 1.7A Minimum Output Current Limit Over Temperature
- Cycle-by-Cycle Current Limit
- PWM Dimming with Dedicated Logic Input
- PWM Dimming with Power Input Voltage
- Simple Control Loop Compensation
- Low Power Shutdown
- Supports All-Ceramic Output Capacitors and Capacitor-less Outputs
- Thermal Shutdown Protection
- TSSOP-14 Package

2 APPLICATIONS

- LED Driver
- Constant Current Source
- Automotive Lighting
- General Illumination
- Industrial Lighting

3.1 TYPICAL APPLICATION

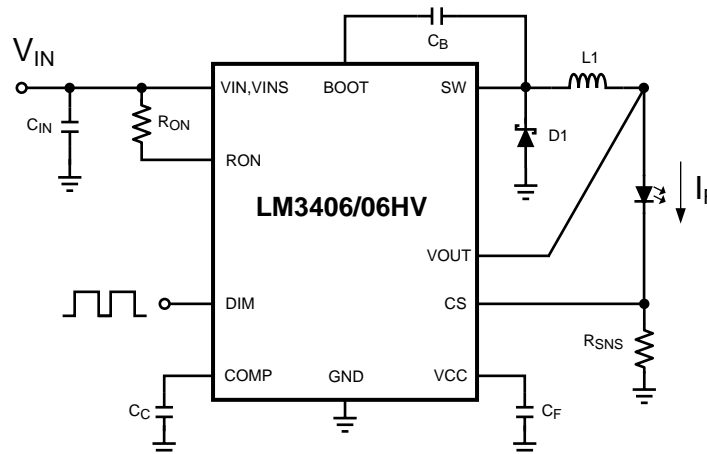

3 DESCRIPTION

The LM3406 family are monolithic switching regulators designed to deliver constant currents to high power LEDs. Ideal for automotive, industrial, and general lighting applications, they contain a high-side N-channel MOSFET switch with a current limit of 2.0A (typical) for step-down (Buck) regulators. Controlled on-time with true average current and an external current sense resistor allow the converter output voltage to adjust as needed to deliver a constant current to series and series-parallel connected LED arrays of varying number and type. LED dimming via pulse width modulation (PWM) is achieved using a dedicated logic pin or by PWM of the power input voltage. The product feature set is rounded out with low-power shutdown and thermal shutdown protection.

The LM3406HV-Q1 is AEC-Q100 grade 1 qualified.



3.1 Electrostatic Discharge Caution



These devices have limited built-in ESD protection. The leads should be shorted together or the device placed in conductive foam during storage or handling to prevent electrostatic damage to the MOS gates.

3.1 CONNECTION DIAGRAM

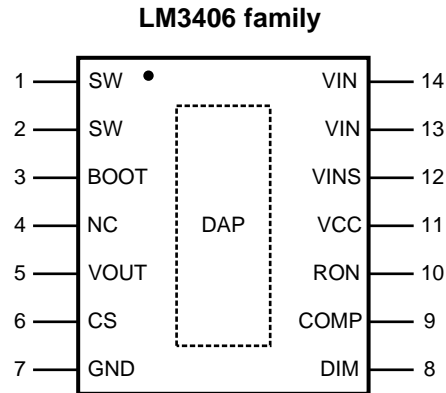

**14-Lead Exposed Pad Plastic TSSOP Package
See Package Number PWP0014A**

PIN DESCRIPTIONS

Pin(s)	Name	Description	Application Information
1,2	SW	Switch pin	Connect these pins to the output inductor and Schottky diode.
3	BOOT	MOSFET drive bootstrap pin	Connect a 22 nF ceramic capacitor from this pin to the SW pins.
4	NC	No Connect	No internal connection. Leave this pin unconnected.
5	VOUT	Output voltage sense pin	Connect this pin to the output node where the inductor and the first LED's anode connect.
6	CS	Current sense feedback pin	Set the current through the LED array by connecting a resistor from this pin to ground.
7	GND	Ground pin	Connect this pin to system ground.
8	DIM	Input for PWM dimming	Connect a logic-level PWM signal to this pin to enable/disable the power MOSFET and reduce the average light output of the LED array. Logic high = output on, logic low - output off.
9	COMP	Error amplifier output	Connect a 0.1 μ F ceramic capacitor with X5R or X7R dielectric from this pin to ground.
10	RON	On-time control pin	A resistor connected from this pin to VIN sets the regulator controlled on-time.
11	VCC	Output of the internal 7V linear regulator	Bypass this pin to ground with a minimum 0.1 μ F ceramic capacitor with X5R or X7R dielectric.
12	VINS	Input voltage PWM dimming comparator input	Connect this pin to the anode of the input diode to allow dimming by PWM of the input voltage
13,14	VIN	Input voltage pin	Nominal operating input range for this pin is 6V to 42V (LM3406) or 6V to 75V (LM3406HV, LM3406HV-Q1).
DAP	DAP	Thermal Pad	Connect to ground. Place 4-6 vias from DAP to bottom layer ground plane.

4 ABSOLUTE MAXIMUM RATINGS ⁽¹⁾

If Military/Aerospace specified devices are required, contact the Texas Instruments Semiconductor Sales Office/ Distributors for availability and specifications.

VIN to GND	LM3406	–0.3V to 45V
	LM3406HV, LM3406HV-Q1	–0.3V to 76V
VINS to GND	LM3406	–0.3V to 45V
	LM3406HV, LM3406HV-Q1	–0.3V to 76V
VOUT to GND	LM3406	–0.3V to 45V
	LM3406HV, LM3406HV-Q1	–0.3V to 76V
BOOT to GND	LM3406	–0.3V to 59V
	LM3406HV, LM3406HV-Q1	–0.3V to 76V
SW to GND	LM3406	–1.5V to 45V
	LM3406HV, LM3406HV-Q1	–1.5V to 76V
BOOT to VCC	LM3406	–0.3V to 45V
	LM3406HV, LM3406HV-Q1	–0.3V to 76V
BOOT to SW		–0.3V to 14V
VCC to GND		–0.3V to 14V
DIM to GND		–0.3V to 7V
COMP to GND		–0.3V to 7V
CS to GND		–0.3V to 7V
RON to GND		–0.3V to 7V
Junction Temperature		150°C
Storage Temp. Range		–65°C to 125°C
ESD Rating ⁽²⁾		2kV
Soldering Information		
Lead Temperature (Soldering, 10sec)		260°C
Infrared/Convection Reflow (15sec)		235°C

- (1) Absolute Maximum Ratings indicate limits beyond which damage to the device may occur, including inoperability and degradation of device reliability and/or performance. Functional operation of the device and/or non-degradation at the Absolute Maximum Ratings or other conditions beyond those indicated in the Operating Ratings is not implied. The recommended Operating Ratings indicate conditions at which the device is functional and the device should not be operated beyond such conditions.
- (2) The human body model is a 100 pF capacitor discharged through a 1.5-kΩ resistor into each pin.

5 RECOMMENDED OPERATING CONDITIONS ⁽¹⁾

V _{IN}	LM3406	6V to 42V
	LM3406HV, LM3406HV-Q1	6V to 75V
Junction Temperature Range	LM3406, LM3406HV	–40°C to +125°C
	LM3406HV-Q1	–40°C to +150°C
Ambient Temperature Range	LM3406HV-Q1 ⁽²⁾	–40°C to +125°C
Thermal Resistance θ_{JA} (TSSOP-14 Package) ⁽³⁾		50°C/W

- (1) Absolute Maximum Ratings indicate limits beyond which damage to the device may occur, including inoperability and degradation of device reliability and/or performance. Functional operation of the device and/or non-degradation at the Absolute Maximum Ratings or other conditions beyond those indicated in the Operating Ratings is not implied. The recommended Operating Ratings indicate conditions at which the device is functional and the device should not be operated beyond such conditions.
- (2) The LM3406HV-Q1 can operate at an ambient temperature of up to +125°C as long as the junction temperature maximum of +150°C is not exceeded.
- (3) θ_{JA} of 50°C/W with DAP soldered to a minimum of 2 square inches of 1-oz. copper on the top or bottom PCB layer.

6 ELECTRICAL CHARACTERISTICS LM3406/LM3406HV/LM3406HV-Q1

$V_{IN} = 24V$ unless otherwise indicated. Unless otherwise specified, datasheet typicals and limits apply to LM3406, LM3406HV and LM3406HV-Q1. Typicals and limits appearing in plain type apply for $T_A = T_J = +25^{\circ}C$ ⁽¹⁾. Limits appearing in **boldface type** apply over full Operating Temperature Range. Datasheet min/max specification limits are specified by design, test, or statistical analysis.

Parameter		Test Conditions	Min	Typ	Max	Units
REGULATION COMPARATOR AND ERROR AMPLIFIER						
V_{REF}	CS Regulation Threshold	CS Decreasing, SW turns on	187.5	200	210	mV
			191.0 ⁽²⁾		210.0 ⁽²⁾	
V_{OV}	CS Over-voltage Threshold	CS Increasing, SW turns off		300		mV
I_{CS}	CS Bias Current	CS = 0V		0.9		μA
I_{VOUT}	VOU T Bias Current	VOU T = 24V		83		μA
I_{COMP}	COMP Pin Current	CS = 0V		25		μA
G_{m-CS}	Error Amplifier Transconductance	150 mV < CS < 250 mV		145		μS
SHUTDOWN						
V_{SD-TH}	Shutdown Threshold	RON Increasing	0.3	0.7	1.05	V
	Shutdown Threshold (LM3406HV-Q1)	RON Increasing	0.3	0.7	1.066	
V_{SD-HYS}	Shutdown Hysteresis	RON Decreasing		40		mV
ON AND OFF TIMER						
$t_{OFF-MIN}$	Minimum Off-time	CS = 0V		230		ns
t_{ON}	Programmed On-time	$V_{IN} = 24V, V_O = 12V, R_{ON} = 200k\Omega$	800	1300	1800	
	Programmed On-time (LM3406HV-Q1)	$V_{IN} = 24V, V_O = 12V, R_{ON} = 200k\Omega$	800	1300	1850	
t_{ON-MIN}	Minimum On-time			280		
VINS COMPARATOR						
V_{INS-TH}	VINS Pin Threshold	VINS decreasing		70		%VIN
I_{IN-2WD}	VINS Pin Input Current	VINS = 24V * 0.7		25		μA
INTERNAL REGULATOR						
V_{CC-REG}	V_{CC} Regulated Output	0 mA < I_{CC} < 5 mA	6.4	7	7.4	V
	V_{CC} Regulated Output (LM3406HV-Q1)	0 mA < I_{CC} < 5 mA	6.4	7	7.5	
V_{IN-DO}	$V_{IN} - V_{CC}$	$I_{CC} = 5$ mA, $6.0V < V_{IN} < 8.0V$, Non-switching		300		mV
$V_{CC-BP-TH}$	V_{CC} Bypass Threshold	V_{IN} Increasing		8.8		V
V_{CC-LIM}	V_{CC} Current Limit	$V_{IN} = 24V, V_{CC} = 0V$	4	20		mA
$V_{CC-UV-TH}$	V_{CC} Under-voltage Lock-out Threshold	V_{CC} Increasing		5.3		V
$V_{CC-UV-HYS}$	V_{CC} Under-voltage Lock-out Hysteresis	V_{CC} Decreasing		150		mV
I_{IN-OP}	I_{IN} Operating Current	Non-switching, CS = 0.5V		1.2		mA
I_{IN-SD}	I_{IN} Shutdown Current	RON = 0V		240	350	μA
CURRENT LIMIT						
I_{LIM}	Current Limit Threshold		1.7	2.1	2.7	A
	Current Limit Threshold (LM3406HV-Q1)		1.65	2.1	2.60	
DIM COMPARATOR						
V_{IH}	Logic High	DIM Increasing	2.2			V
V_{IL}	Logic Low	DIM Decreasing			0.8	V
I_{DIM-PU}	DIM Pull-up Current	DIM = 1.5V		80		μA
MOSFET AND DRIVER						
R_{DS-ON}	Buck Switch On Resistance	$I_{SW} = 200$ mA, BOOT = 6.3V		0.37	0.75	Ω
$V_{DR-UVLO}$	BOOT Under-voltage Lock-out Threshold	BOOT–SW Increasing	1.7	2.9	4.3	V
V_{DR-HYS}	BOOT Under-voltage Lock-out Hysteresis	BOOT–SW Decreasing		370		mV
THERMAL SHUTDOWN						
T_{SD}	Thermal Shutdown Threshold			165		$^{\circ}C$
T_{SD-HYS}	Thermal Shutdown Hysteresis			25		$^{\circ}C$

(1) Typical values represent most likely parametric norms at the conditions specified.

(2) Specified with junction temperature from 0°C - 125°C.

ELECTRICAL CHARACTERISTICS LM3406/LM3406HV/LM3406HV-Q1 (continued)

$V_{IN} = 24V$ unless otherwise indicated. Unless otherwise specified, datasheet typicals and limits apply to LM3406, LM3406HV and LM3406HV-Q1. Typicals and limits appearing in plain type apply for $T_A = T_J = +25^{\circ}C$ ⁽¹⁾. Limits appearing in **boldface type** apply over full Operating Temperature Range. Datasheet min/max specification limits are specified by design, test, or statistical analysis.

Parameter		Test Conditions	Min	Typ	Max	Units
THERMAL RESISTANCE						
θ_{JA}	Junction to Ambient	TSSOP-14 Package ⁽³⁾		50		$^{\circ}C/W$

(3) θ_{JA} of $50^{\circ}C/W$ with DAP soldered to a minimum of 2 square inches of 1-oz. copper on the top or bottom PCB layer.

7 TYPICAL PERFORMANCE CHARACTERISTICS

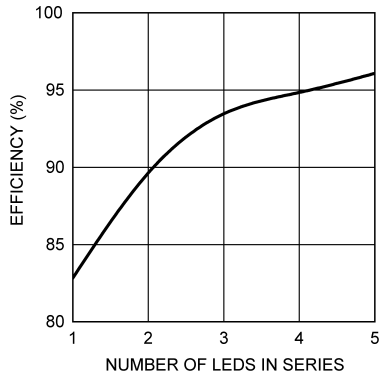

Figure 1. Efficiency vs. Number of InGaN LEDs in Series

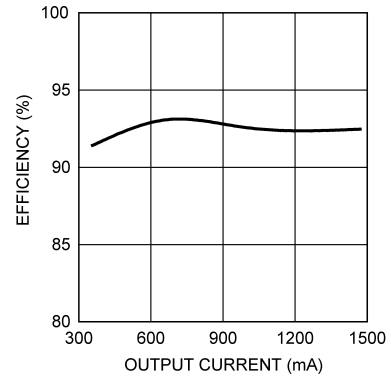

Figure 2. Efficiency Vs. Output Current (1)

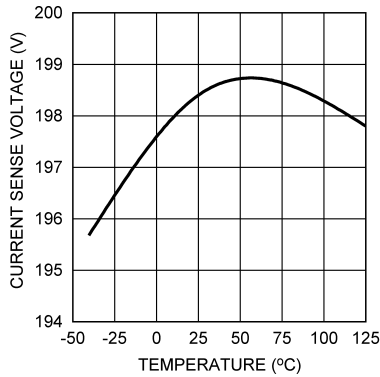

Figure 3. VREF vs Temperature

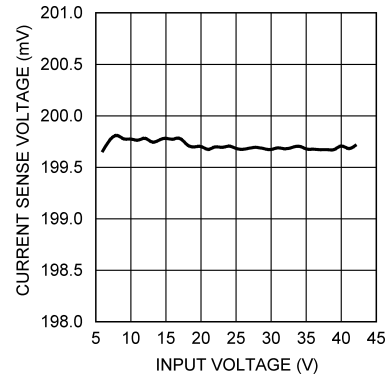

Figure 4. VREF vs VIN, LM3406

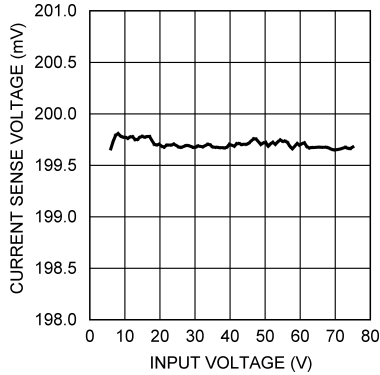

Figure 5. VREF vs VIN, LM3406HV/LM3406HV-Q1

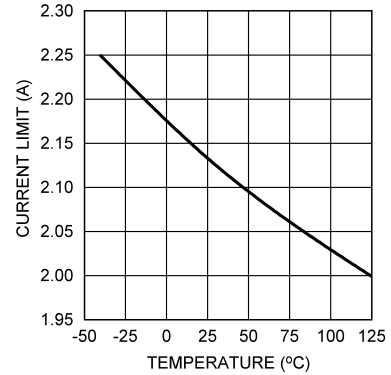

Figure 6. Current Limit vs Temperature

(1) $V_{IN} = 24V$, $I_F = 1A$, $T_A = 25^\circ C$, and the load consists of three InGaN LEDs in series unless otherwise noted. See the Bill of Materials table at the end of the datasheet.

TYPICAL PERFORMANCE CHARACTERISTICS (continued)

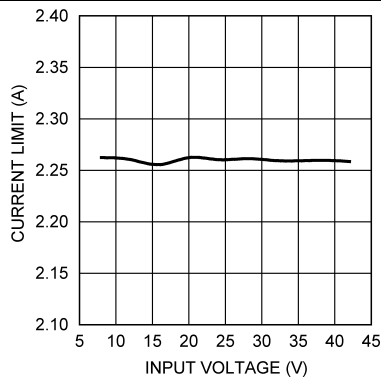

Figure 7. Current Limit vs V_{IN} , LM3406

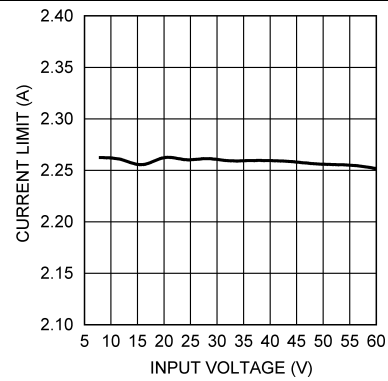

Figure 8. Current Limit vs V_{IN} , LM3406HV/LM3406HV-Q1

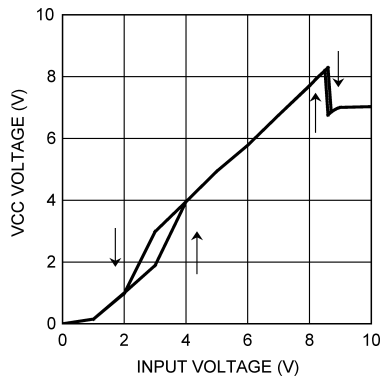

Figure 9. V_{CC} vs V_{IN}

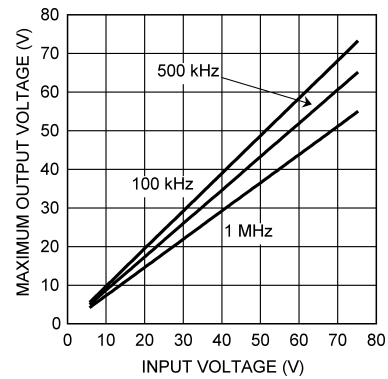
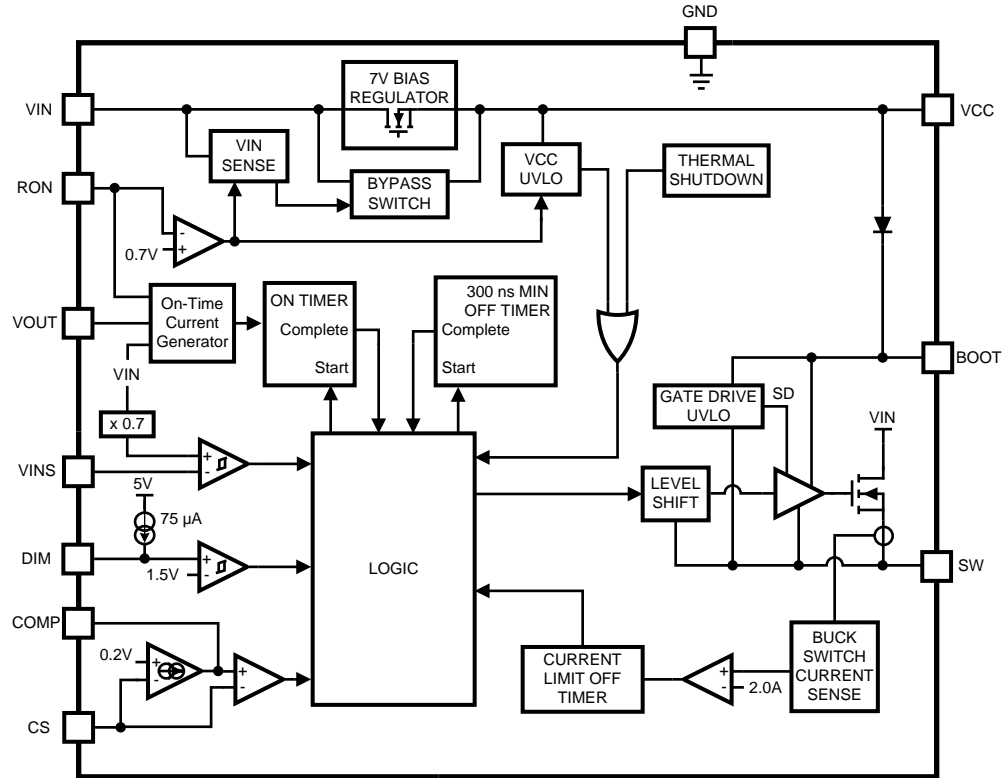

Figure 10. V_{O-MAX} vs V_{IN} , LM3406

7.1 BLOCK DIAGRAM



8 APPLICATION INFORMATION

8.1 THEORY OF OPERATION

The LM3406, LM3406HV and LM3406HV-Q1 are buck regulators with a wide input voltage range, low voltage reference, and a fast output enable/disable function. These features combine to make them ideal for use as a constant current source for LEDs with forward currents as high as 1.5A. The controlled on-time (COT) architecture uses a comparator and a one-shot on-timer that varies inversely with input and output voltage instead of a fixed clock. The LM3406 family also employs an integrator circuit that averages the output current. When the converter runs in continuous conduction mode (CCM) the controlled on-time maintains a constant switching frequency over changes in both input and output voltage. These features combine to give the LM3406 family an accurate output current, fast transient response, and constant switching frequency over a wide range of conditions.

8.2 CONTROLLED ON-TIME OVERVIEW

shows a simplified version of the feedback system used to control the current through an array of LEDs. A differential voltage signal, V_{SNS} , is created as the LED current flows through the current setting resistor, R_{SNS} . V_{SNS} is fed back by the CS pin, where it is integrated and compared against an error amplifier-generated reference. The error amplifier is a transconductance (G_m) amplifier which adjusts the voltage on COMP to maintain a 200 mV average at the CS pin. The on-comparator turns on the power MOSFET when V_{SNS} falls below the reference created by the G_m amp. The power MOSFET conducts for a controlled on-time, t_{ON} , set by an external resistor, R_{ON} , the input voltage, V_{IN} and the output voltage, V_O . On-time can be estimated by the following simplified equation (for the most accurate version of this expression see the Appendix):

$$t_{ON} = 1 \times 10^{-11} \times R_{ON} \times \frac{V_O}{V_{IN}} \quad (1)$$

At the conclusion of t_{ON} the power MOSFET turns off and must remain off for a minimum of 230 ns. Once this $t_{OFF-MIN}$ is complete the CS comparator compares the integrated V_{SNS} and reference again, waiting to begin the next cycle.

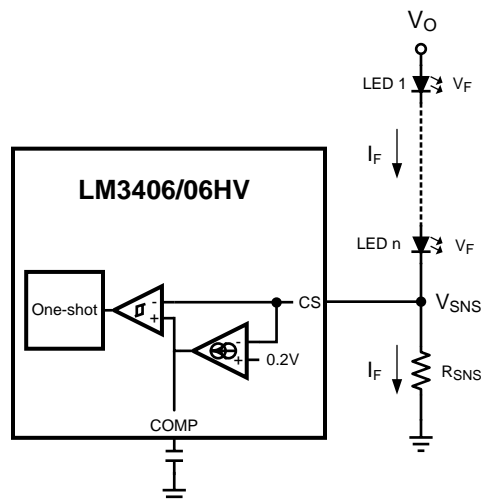

Comparator and One-Shot

8.3 SWITCHING FREQUENCY

The LM3406 family does not contain a clock, however the on-time is modulated in proportion to both input voltage and output voltage in order to maintain a relatively constant frequency. On-time t_{ON} , duty cycle D and switching frequency f_{SW} are related by the following expression:

$$f_{SW} = D / t_{ON} \quad (2)$$

$$D = (V_O + V_D) / (V_{IN} - V_{SW} + V_D) \quad (3)$$

$$V_D = \text{Schottky diode (typically 0.5V)} \quad (4)$$

$$V_{SW} = I_F \times R_{DS(ON)} \quad (5)$$

The LM3406 family regulators should be operated in continuous conduction mode (CCM), where inductor current stays positive throughout the switching cycle. During steady-state CCM operation, the converter maintains a constant switching frequency that can be estimated using the following equation (for the most accurate version, particularly for applications that will have an input or output voltage of less than approximately 12V, see the Appendix):

$$f_{SW} = \frac{1}{1 \times 10^{-11} \times R_{ON}} \quad (6)$$

(7)

8.4 SETTING LED CURRENT

LED current is set by the resistor R_{SNS} , which can be determined using the following simple expression due to the output averaging:

$$R_{SNS} = 0.2 / I_F \quad (8)$$

8.5 MAXIMUM NUMBER OF SERIES LEDS

LED driver designers often want to determine the highest number of LEDs that can be driven by their circuits. The limit on the maximum number of series LEDs is set by the highest output voltage, V_{O-MAX} , that the LED driver can provide. A buck regulator cannot provide an output voltage that is higher than the minimum input voltage, and in practice the maximum output voltage of the LM3406 family is limited by the minimum off-time as well. V_{O-MAX} determines how many LEDs can be driven in series. Referring to the illustration in , output voltage is calculated as:

$$V_{O-MAX} = V_{IN-MIN} \times (1 - f_{SW} \times t_{OFF-MIN}) \quad (9)$$

$$t_{OFF-MIN} = 230 \text{ ns}$$

Once V_{O-MAX} has been calculated, the maximum number of series LEDs, n_{MAX} , can be calculated by the following expression and rounding down:

$$n_{MAX} = V_{O-MAX} / V_F \quad (10)$$

V_F = forward voltage of each LED

At low switching frequency V_{O-MAX} is higher, allowing the LM3406 family to regulate output voltages that are nearly equal to input voltage, and this can allow the system to drive more LEDs in series. Low switching frequencies are not always desirable, however, because they require larger, more expensive components.

8.6 CALCULATING OUTPUT VOLTAGE

Even though output current is the controlled parameter in LED drivers, output voltage must still be calculated in order to design the complete circuit. Referring to the illustration in , output voltage is calculated as:

$$V_O = n \times V_F + V_{SNS} \quad (11)$$

V_{SNS} = sense voltage of 200 mV, n = number of LEDs in series

8.7 MINIMUM ON-TIME

The minimum on-time for the LM3406 family is 280 ns (typical). One practical example of reaching the minimum on-time is when dimming the LED light output with a power FET placed in parallel to the LEDs. When the FET is on, the output voltage drops to 200 mV. This results in a small duty cycle and in most circuits requires an on-time that would be less than 280 ns. In such a case the LM3406 family keeps the on-time at 280 ns and increases the off-time as much as needed, which effectively reduces the switching frequency.

8.8 HIGH VOLTAGE BIAS REGULATOR (VCC)

The LM3406 family contains an internal linear regulator with a 7V output, connected between the VIN and the VCC pins. The VCC pin should be bypassed to the GND pin with a 0.1 μ F ceramic capacitor connected as close as possible to the pins of the IC. VCC tracks VIN until VIN reaches 8.8V (typical) and then regulates at 7V as VIN increases. The LM3406 family comes out of UVLO and begins operating when VCC crosses 5.3V. This is shown graphically in the Typical Performance curves.

Connecting an external supply to VCC to power the gate drivers is not recommended. However, it may be done if certain precautions are taken. Be sure that the external supply will not violate any absolute maximum conditions and will at no point exceed the voltage applied to the VIN pins. Under certain conditions, some ringing may be present on the SW and BOOT pins when VCC is driven with an external supply. It is important to ensure that the absolute maximum ratings of these pins are not violated during the ringing or else damage to the device may occur.

8.9 INTERNAL MOSFET AND DRIVER

The LM3406 family features an internal power MOSFET as well as a floating driver connected from the SW pin to the BOOT pin. Both rise time and fall time are 20 ns each (typical) and the approximate gate charge is 9 nC. The high-side rail for the driver circuitry uses a bootstrap circuit consisting of an internal high-voltage diode and an external 22 nF capacitor, C_B . V_{CC} charges C_B through the internal diode while the power MOSFET is off. When the MOSFET turns on, the internal diode reverse biases. This creates a floating supply equal to the V_{CC} voltage minus the diode drop to drive the MOSFET when its source voltage is equal to V_{IN} .

8.10 FAST LOGIC PIN FOR PWM DIMMING

The DIM pin is a TTL compatible input for PWM dimming of the LED. A logic low (below 0.8V) at DIM will disable the internal MOSFET and shut off the current flow to the LED array. While the DIM pin is in a logic low state the support circuitry (driver, bandgap, VCC) remains active in order to minimize the time needed to turn the LED array back on when the DIM pin sees a logic high (above 2.2V). A 75 μ A (typical) pull-up current ensures that the LM3406 family is on when DIM pin is open circuited, eliminating the need for a pull-up resistor. Dimming frequency, f_{DIM} , and duty cycle, D_{DIM} , are limited by the LED current rise time and fall time and the delay from activation of the DIM pin to the response of the internal power MOSFET. In general, f_{DIM} should be at least one order of magnitude lower than the steady state switching frequency in order to prevent aliasing.

8.11 INPUT VOLTAGE COMPARATOR FOR PWM DIMMING

Adding an external input diode and using the internal VINS comparator allows the LM3406 family to sense and respond to dimming that is done by PWM of the input voltage. This method is also referred to as "Two-Wire Dimming", and a typical application circuit is shown in . If the VINS pin voltage falls 70% below the VIN pin voltage, the LM3406 family disables the internal power FET and shuts off the current to the LED array. The support circuitry (driver, bandgap, VCC) remains active in order to minimize the time needed to the turn the LED back on when the VINS pin voltage rises and exceeds 70% of VIN. This minimizes the response time needed to turn the LED array back on.

INPUT VOLTAGE COMPARATOR FOR PWM DIMMING (continued)

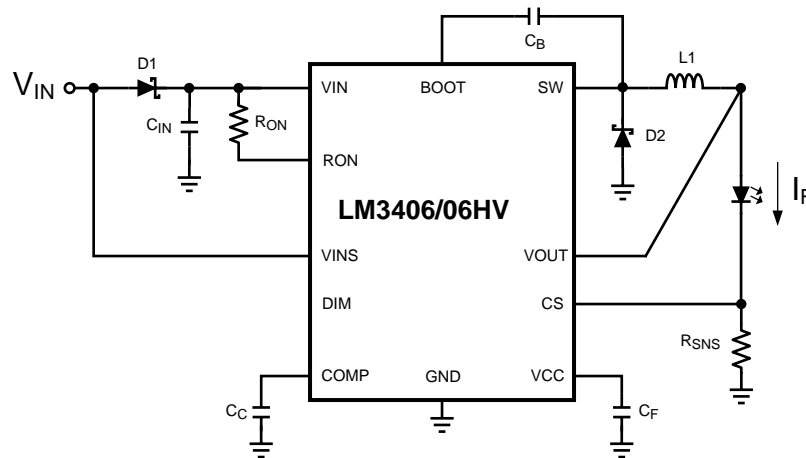

Typical Application using Two-Wire Dimming

8.12 PARALLEL MOSFET FOR HIGH-SPEED PWM DIMMING

For applications that require dimming at high frequency or with wide dimming duty cycle range neither the VINS comparator or the DIM pin are capable of slewing the LED current from 0 to the target level fast enough. For such applications the LED current slew rate can be increased by shorting the LED current with a N-MOSFET placed in parallel to the LED or LED array, as shown in . While the parallel FET is on the output current flows through it, effectively reducing the output voltage to equal the CS pin voltage of 0.2V. This dimming method maintains a continuous current through the inductor, and therefore eliminates the biggest delay in turning the LED(s) on and off. The trade-off with parallel FET dimming is that more power is wasted while the FET is on, although in most cases the power wasted is small compared to the power dissipated in the LEDs. Parallel FET circuits should use no output capacitance or a bare minimum for noise filtering in order to minimize the slew rate of output voltage. Dimming FET Q1 can be driven from a ground-referenced source because the source stays at 0.2V along with the CS pin.

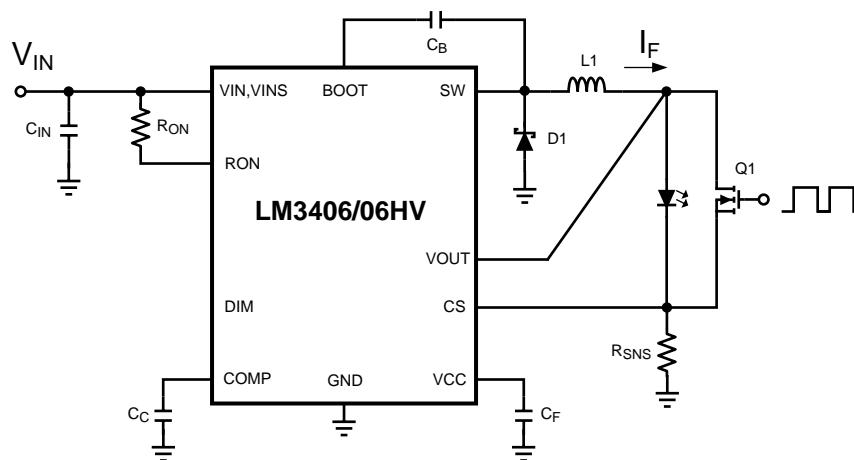

Dimming with a Parallel FET

8.16 LOW POWER SHUTDOWN

The LM3406 family can be placed into a low power state ($I_{IN-SD} = 240 \mu A$) by grounding the RON pin with a signal-level MOSFET as shown in . Low power MOSFETs like the 2N7000, 2N3904, or equivalent are recommended devices for putting the LM3406 family into low power shutdown. Logic gates can also be used to shut down the LM3406 family as long as the logic low voltage is below the over temperature minimum threshold of 0.3V. Noise filter circuitry on the RON pin can cause a few pulses with longer on-times than normal after RON is grounded or released. In these cases the OVP/OCP comparator will ensure that the peak inductor or LED current does not exceed $300 \text{ mV} / R_{SNS}$.

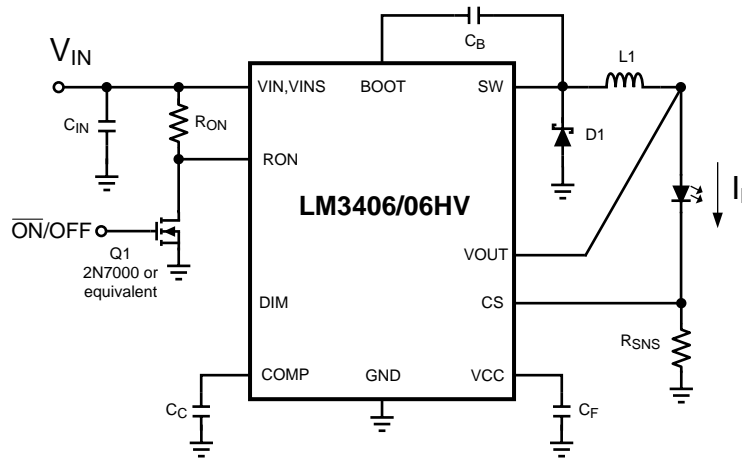

Low Power Shutdown

8.17 THERMAL SHUTDOWN

Internal thermal shutdown circuitry is provided to protect the IC in the event that the maximum junction temperature is exceeded. The threshold for thermal shutdown is 165°C with a 25°C hysteresis (both values typical). During thermal shutdown the MOSFET and driver are disabled.

8.1 DESIGN CONSIDERATIONS

8.1.1 SWITCHING FREQUENCY

Switching frequency is selected based on the trade-offs between efficiency (better at low frequency), solution size/cost (smaller at high frequency), and the range of output voltage that can be regulated (wider at lower frequency.) Many applications place limits on switching frequency due to EMI sensitivity. The on-time of the LM3406 family can be programmed for switching frequencies ranging from the 10's of kHz to over 1 MHz. This on-time varies in proportion to both V_{IN} and V_O in order to maintain first-order control over switching frequency, however in practice the switching frequency will shift in response to large swings in V_{IN} or V_O . The maximum switching frequency is limited only by the minimum on-time and minimum off-time requirements.

8.1.2 LED RIPPLE CURRENT

Selection of the ripple current, Δi_F , through the LED array is similar to the selection of output ripple voltage in a standard voltage regulator. Where the output ripple in a voltage regulator is commonly $\pm 1\%$ to $\pm 5\%$ of the DC output voltage, LED manufacturers generally recommend values for Δi_F ranging from $\pm 5\%$ to $\pm 20\%$ of I_F . Higher LED ripple current allows the use of smaller inductors, smaller output capacitors, or no output capacitors at all. Lower ripple current requires more output inductance, higher switching frequency, or additional output capacitance, and may be necessary for applications that are not intended for human eyes, such as machine vision or industrial inspection.

8.1.3 BUCK CONVERTERS WITHOUT OUTPUT CAPACITORS

The buck converter is unique among non-isolated topologies because of the direct connection of the inductor to the load during the entire switching cycle. By definition an inductor will control the rate of change of current that flows through it, and this control over current ripple forms the basis for component selection in both voltage regulators and current regulators. A current regulator such as the LED driver for which the LM3406 family was designed focuses on the control of the current through the load, not the voltage across it. A constant current regulator is free of load current transients, and has no need of output capacitance to supply the load and maintain output voltage. Referring to the Typical Application circuit on the front page of this datasheet, the inductor and LED can form a single series chain, sharing the same current. When no output capacitor is used, the same equations that govern inductor ripple current, Δi_L , also apply to the LED ripple current, Δi_F . For a controlled on-time converter such as LM3406 family the ripple current is described by the following expression:

$$\Delta i_L = \Delta i_F = \frac{V_{IN} - V_O}{L} \times t_{ON} \quad (12)$$

The triangle-wave inductor current ripple flows through R_{SNS} and produces a triangle-wave voltage at the CS pin. To provide good signal to noise ratio (SNR) the amplitude of CS pin ripple voltage, ΔV_{CS} , should be at least 25 mV_{P-P}. ΔV_{CS} is described by the following:

$$\Delta V_{CS} = \Delta i_F \times R_{SNS} \quad (13)$$

8.1.4 BUCK CONVERTERS WITH OUTPUT CAPACITORS

A capacitor placed in parallel with the LED(s) can be used to reduce the LED current ripple while keeping the same average current through both the inductor and the LED array. With an output capacitor the output inductance can be lowered, making the magnetics smaller and less expensive. Alternatively, the circuit could be run at lower frequency but keep the same inductor value, improving the power efficiency. Both the peak current limit and the OVP/OCP comparator still monitor peak inductor current, placing a limit on how large Δi_L can be even if Δi_F is made very small. Adding a capacitor that reduces Δi_F to well below the target provides headroom for changes in inductance or V_{IN} that might otherwise push the peak LED ripple current too high.

shows the equivalent impedances presented to the inductor current ripple when an output capacitor, C_O , and its equivalent series resistance (ESR) are placed in parallel with the LED array. Note that ceramic capacitors have so little ESR that it can be ignored. The entire inductor ripple current still flows through R_{SNS} to provide the required 25 mV of ripple voltage for proper operation of the CS comparator.

DESIGN CONSIDERATIONS (continued)

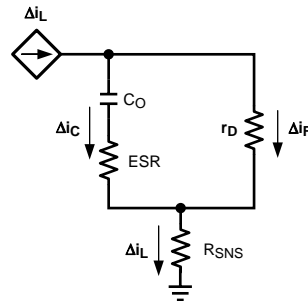

LED and C_0 Ripple Current

To calculate the respective ripple currents the LED array is represented as a dynamic resistance, r_D . LED dynamic resistance is not always specified on the manufacturer's datasheet, but it can be calculated as the inverse slope of the LED's V_F vs. I_F curve. Note that dividing V_F by I_F will give an incorrect value that is 5x to 10x too high. Total dynamic resistance for a string of n LEDs connected in series can be calculated as the r_D of one device multiplied by n . Inductor ripple current is still calculated with the expression from Buck Regulators without Output Capacitors. The following equations can then be used to estimate Δi_F when using a parallel capacitor:

$$\Delta i_F = \frac{\Delta i_L}{1 + \frac{r_D}{Z_C}}$$

$$Z_C = ESR + \frac{1}{2\pi \times f_{SW} \times C_0} \quad (14)$$

The calculation for Z_C assumes that the shape of the inductor ripple current is approximately sinusoidal.

Small values of C_0 that do not significantly reduce Δi_F can also be used to control EMI generated by the switching action of the LM3406 family. EMI reduction becomes more important as the length of the connections between the LED and the rest of the circuit increase.

8.1.5 INPUT CAPACITORS

Input capacitors at the VIN pin of the LM3406 family are selected using requirements for minimum capacitance and rms ripple current. The input capacitors supply pulses of current approximately equal to I_F while the power MOSFET is on, and are charged up by the input voltage while the power MOSFET is off. All switching regulators have a negative input impedance due to the decrease in input current as input voltage increases. This inverse proportionality of input current to input voltage can cause oscillations (sometimes called 'power supply interaction') if the magnitude of the negative input impedance is greater than the input filter impedance. Minimum capacitance can be selected by comparing the input impedance to the converter's negative resistance; however this requires accurate calculation of the input voltage source inductance and resistance, quantities which can be difficult to determine. An alternative method to select the minimum input capacitance, $C_{IN(MIN)}$, is to select the maximum input voltage ripple which can be tolerated. This value, $\Delta V_{IN(MAX)}$, is equal to the change in voltage across C_{IN} during the converter on-time, when C_{IN} supplies the load current. $C_{IN(MIN)}$ can be selected with the following:

$$C_{IN(MIN)} = \frac{I_F \times t_{ON}}{\Delta V_{IN(MAX)}} \quad (15)$$

A good starting point for selection of C_{IN} is to use an input voltage ripple of 5% to 10% of V_{IN} . A minimum input capacitance of 2x the $C_{IN(MIN)}$ value is recommended for all LM3406 family circuits. To determine the rms current rating, the following formula can be used:

$$I_{N(rms)} = I_F \times \sqrt{D(1-D)} \quad (16)$$

DESIGN CONSIDERATIONS (continued)

Ceramic capacitors are the best choice for the input to the LM3406 family due to their high ripple current rating, low ESR, low cost, and small size compared to other types. When selecting a ceramic capacitor, special attention must be paid to the operating conditions of the application. Ceramic capacitors can lose one-half or more of their capacitance at their rated DC voltage bias and also lose capacitance with extremes in temperature. A DC voltage rating equal to twice the expected maximum input voltage is recommended. In addition, the minimum quality dielectric which is suitable for switching power supply inputs is X5R, while X7R or better is preferred.

8.1.6 RECIRCULATING DIODE

The LM3406 family is a non-synchronous buck regulator that requires a recirculating diode D1 (see the Typical Application circuit) to carrying the inductor current during the MOSFET off-time. The most efficient choice for D1 is a Schottky diode due to low forward drop and near-zero reverse recovery time. D1 must be rated to handle the maximum input voltage plus any switching node ringing when the MOSFET is on. In practice all switching converters have some ringing at the switching node due to the diode parasitic capacitance and the lead inductance. D1 must also be rated to handle the average current, I_D , calculated as:

$$I_D = (1 - D) \times I_F \quad (17)$$

This calculation should be done at the maximum expected input voltage. The overall converter efficiency becomes more dependent on the selection of D1 at low duty cycles, where the recirculating diode carries the load current for an increasing percentage of the time. This power dissipation can be calculating by checking the typical diode forward voltage, V_D , from the I-V curve on the product datasheet and then multiplying it by I_D . Diode datasheets will also provide a typical junction-to-ambient thermal resistance, θ_{JA} , which can be used to estimate the operating die temperature of the device. Multiplying the power dissipation ($P_D = I_D \times V_D$) by θ_{JA} gives the temperature rise. The diode case size can then be selected to maintain the Schottky diode temperature below the operational maximum.

8.2 Transient Protection Considerations

Considerations need to be made when external sources, loads or connections are made to the switching converter circuit due to the possibility of Electrostatic Discharge (ESD) or Electric Over Stress (EOS) events occurring and damaging the integrated circuit (IC) device. All IC device pins contain zener based clamping structures that are meant to clamp ESD. ESD events are very low energy events, typically less than 5µJ (microjoules). Any event that transfers more energy than this may damage the ESD structure. Damage is typically represented as a short from the pin to ground as the extreme localized heat of the ESD / EOS event causes the aluminum metal on the chip to melt, causing the short. This situation is common to all integrated

8.2.1 CS PIN PROTECTION

When hot swapping in a load (e.g. test points, load boards, LED stack), any residual charge on the load will be immediately transferred through the output capacitor to the CS pin, which is then damaged as shown in below. The EOS event due to the residual charge from the load is represented as $V_{TRANSIENT}$.

From measurements, we know that the 8V ESD structure on the CS pin can typically withstand 25mA of direct current (DC). Adding a 1kΩ resistor in series with the CS pin, shown in , results in the majority of the transient energy to pass through the discrete sense resistor rather than the device. The series resistor limits the peak current that can flow during a transient event, thus protecting the CS pin. With the 1kΩ resistor shown, a 33V, 49A transient on the LED return connector terminal could be absorbed as calculated by:

$$V = 25\text{mA} \times 1\text{k}\Omega + 8\text{V} = 33\text{V} \quad (18)$$

$$I = 33\text{V} / 0.67\Omega = 49\text{A} \quad (19)$$

This is an extremely high energy event, so the protection measures previously described should be adequate to solve this issue.

Transient Protection Considerations (continued)

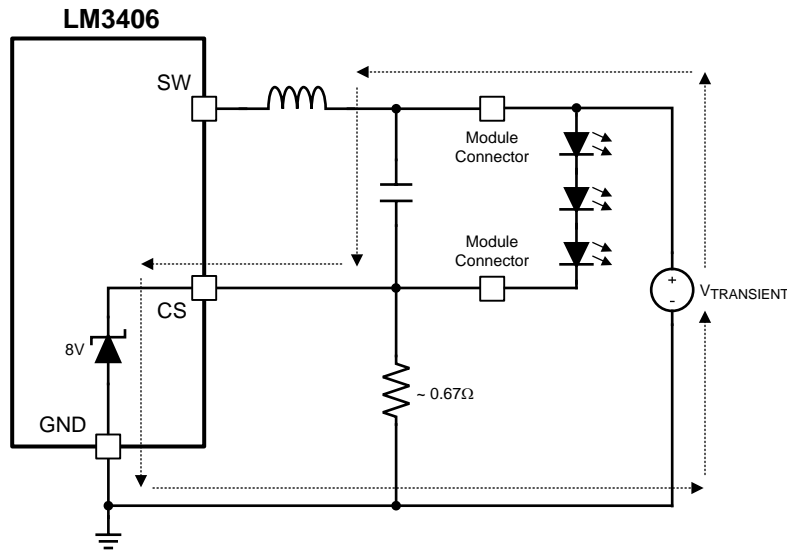

CS Pin, Transient Path

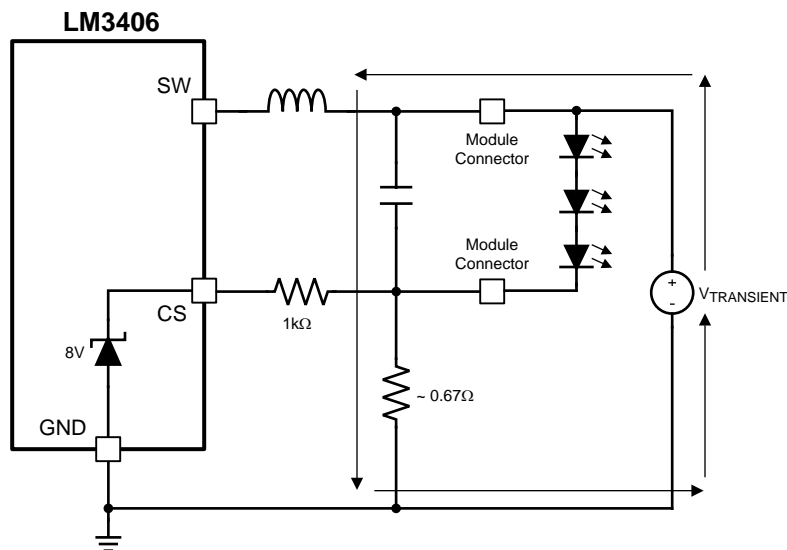

CS Pin, Transient Path with Protection

Adding a resistor in series with the CS pin causes the observed output LED current to shift very slightly. The reason for this is twofold: (1) the CS pin has about 20pF of inherent capacitance inside it which causes a slight delay (20ns for a 1kΩ series resistor), and (2) the comparator that is watching the voltage at the CS pin uses a pnp bipolar transistor at its input. The base current of this pnp transistor is approximately 100nA which will cause a 0.1mV change in the 200mV threshold. These are both very minor changes and are well understood. The shift in current can either be neglected or taken into consideration by changing the current sense resistance slightly.

8.2.2 CS PIN PROTECTION WITH OVP

When designing output overvoltage protection into the switching converter circuit using a zener diode, transient protection on the CS pin requires additional consideration. As shown in , adding a zener diode from the output to the CS pin (with the series resistor) for output overvoltage protection will now again allow the transient energy to be passed through the CS pin's ESD structure thereby damaging it.

Transient Protection Considerations (continued)

Adding an additional series resistor to the CS pin as shown in will result in the majority of the transient energy to pass through the sense resistor thereby protecting the LM340X device.

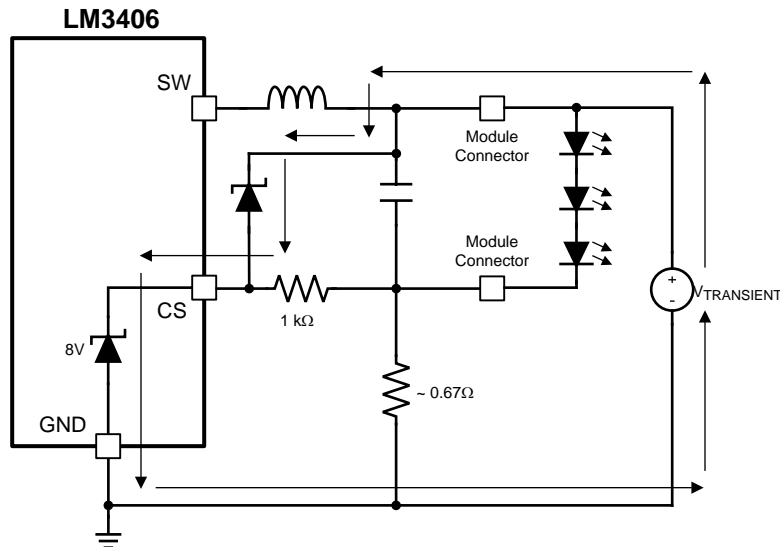

CS Pin with OVP, Transient Path

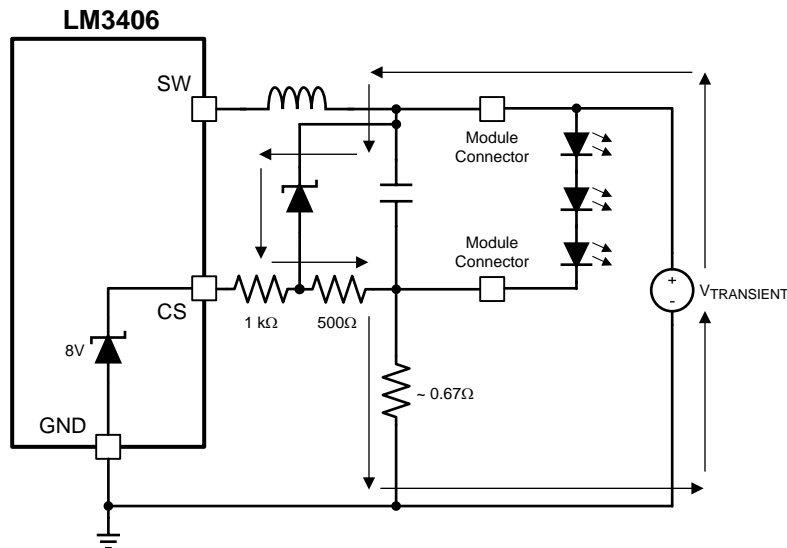

CS Pin with OVP, Transient Path with Protection

8.2.3 VIN PIN PROTECTION

The VIN pin also has an ESD structure from the pin to GND with a breakdown voltage of approximately 80V. Any transient that exceeds this voltage may damage the device. Although transient absorption is usually present at the front end of a switching converter circuit, damage to the VIN pin can still occur.

Transient Protection Considerations (continued)

When V_{IN} is hot swapped in, the current that rushes in to charge C_{IN} up to the V_{IN} value also charges (energizes) the circuit board trace inductance as shown in . The excited trace inductance then resonates with the input capacitance (similar to an under-damped LC tank circuit) and causes voltages at the V_{IN} pin to rise well in excess of both V_{IN} and the voltage at the module input connector as clamped by the input TVS. If the resonating voltage at the V_{IN} pin exceeds the 80V breakdown voltage of the ESD structure, the ESD structure will activate and then “snap-back” to a lower voltage due to its inherent design. If this lower snap-back voltage is less than the applied nominal V_{IN} voltage, then significant current will flow through the ESD structure resulting in the IC being damaged.

An additional TVS or small zener diode should be placed as close as possible to the V_{IN} pins of each IC on the board, in parallel with the input capacitor as shown in . A minor amount of series resistance in the input line would also help, but would lower overall conversion efficiency. For this reason, NTC resistors are often used as inrush limiters instead.

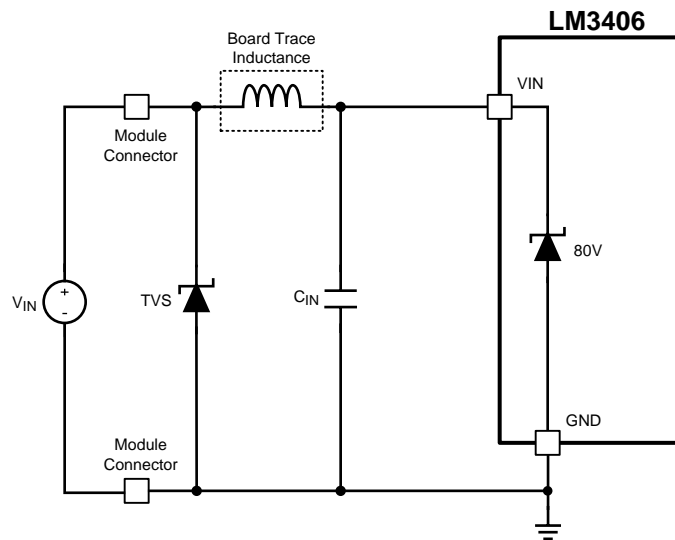

VIN Pin with Typical Input Protection

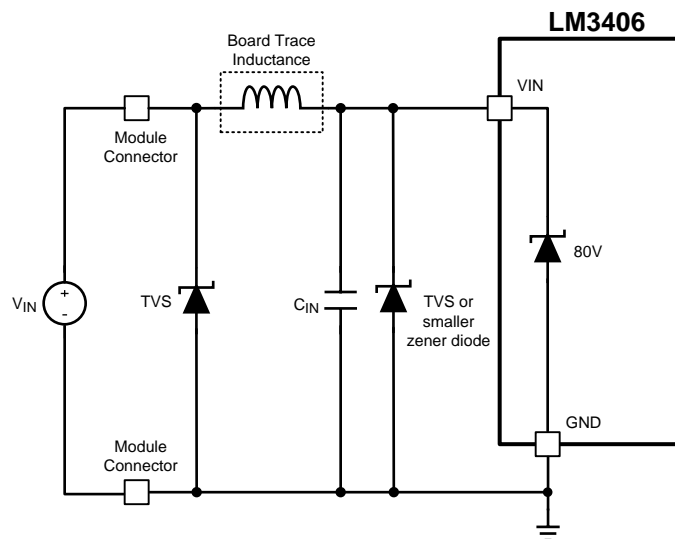

VIN Pin with Additional Input Protection

Transient Protection Considerations (continued)

8.2.4 GENERAL COMMENTS REGARDING OTHER PINS

Any pin that goes “off-board” through a connector should have series resistance of at least 1kΩ to 10kΩ in series with it to protect it from ESD or other transients. These series resistors limit the peak current that can flow (or cause a voltage drop) during a transient event, thus protecting the pin and the device. Pins that are not used should **not** be left floating. They should instead be tied to GND or to an appropriate voltage through resistance.

8.3 Design Example 1

The first example circuit uses the LM3406 to create a flexible LED driver capable of driving anywhere from one to five white series-connected LEDs at a current of 1.5A ±5% from a regulated DC voltage input of 24V ±10%. In addition to the ±5% tolerance specified for the average output current, the LED ripple current must be controlled to 10%_{P-P} of the DC value, or 150 mA_{P-P}. The typical forward voltage of each individual LED at 1.5A is 3.9V, hence the output voltage ranges from 4.1V to 19.7V, adding in the 0.2V drop for current sensing. A complete bill of materials can be found in [Table 1](#) at the end of this datasheet.

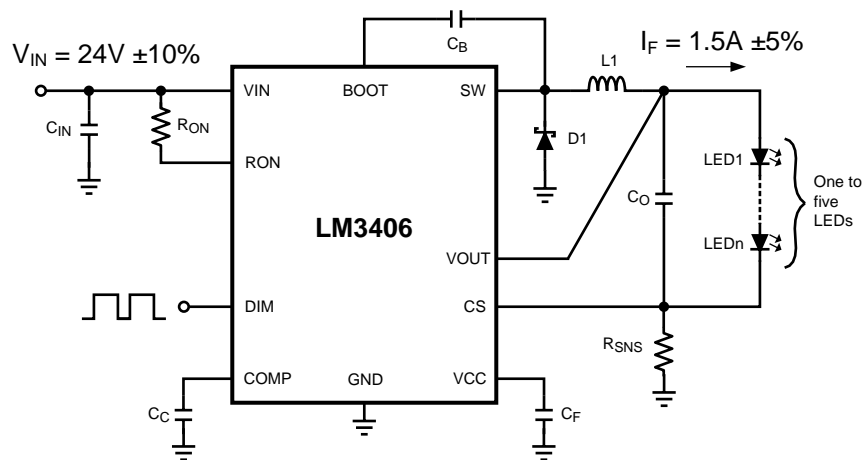

Schematic for Design Example 1

8.3.1 RON and tON

A moderate switching frequency of 500 kHz will balance the requirements of inductor size and overall power efficiency. The LM3406 will allow some shift in switching frequency when V_O changes due to the number of LEDs in series, so the calculation for R_{ON} is done at the mid-point of three LEDs in series, where $V_O = 11.8V$. Note that the actual R_{ON} calculation is done with the high accuracy expression listed in the Appendix.

$$R_{ON} = \frac{1}{f_{SW} \times 1 \times 10^{-11}} \quad (20)$$

$$R_{ON} = 144 \text{ k}\Omega \quad (21)$$

The closest 1% tolerance resistor is 143 kΩ. The switching frequency and on-time of the circuit should be checked for one, three and five LEDs using the equations relating R_{ON} and t_{ON} to f_{SW} . As with the R_{ON} calculation, the actual f_{SW} and t_{ON} values have been calculated using the high accuracy expressions listed in the Appendix.

$$f_{SW} = \frac{1}{1 \times 10^{-11} \times R_{ON}} \quad (22)$$

$$f_{SW(1 \text{ LED})} = 362 \text{ kHz} \quad (23)$$

$$f_{SW(3 \text{ LEDs})} = 504 \text{ kHz} \quad (24)$$

$$f_{SW(5 \text{ LEDs})} = 555 \text{ kHz} \quad (25)$$

$$t_{ON} = 1 \times 10^{-11} \times R_{ON} \times \frac{V_O}{V_{IN}} \quad (26)$$

$$t_{ON(1 \text{ LED})} = 528 \text{ ns} \quad (27)$$

Design Example 1 (continued)

$$t_{ON(3 \text{ LEDs})} = 1014 \text{ ns} \quad (28)$$

$$t_{ON(5 \text{ LEDs})} = 1512 \text{ ns} \quad (29)$$

8.3.2 OUTPUT INDUCTOR

Since an output capacitor will be used to filter some of the AC ripple current, the inductor ripple current can be set higher than the LED ripple current. A value of 40%_{P-P} is typical in many buck converters:

$$\Delta i_L = 0.4 \times 1.5 = 0.6 A_{P-P} \quad (30)$$

With the target ripple current determined the inductance can be chosen:

$$L = \frac{V_{IN} - V_O}{\Delta i_L} \times t_{ON} \quad (31)$$

$$L_{MIN} = [(24 - 11.8) \times 1.01 \times 10^{-6}] / (0.6) = 20.5 \mu\text{H} \quad (32)$$

The closest standard inductor value is 22 μH . The average current rating should be greater than 1.5A to prevent overheating in the inductor. Inductor current ripple should be calculated for one, three and five LEDs:

$$\Delta i_{L(1 \text{ LED})} = [(24 - 4.1) \times 5.28 \times 10^{-7}] / 22 \times 10^{-6} = 478 \text{ mA}_{P-P} \quad (33)$$

$$\Delta i_{L(3 \text{ LEDs})} = [(24 - 11.8) \times 1.01 \times 10^{-6}] / 22 \times 10^{-6} = 560 \text{ mA}_{P-P} \quad (34)$$

$$\Delta i_{L(5 \text{ LEDs})} = [(24 - 19.7) \times 1.51 \times 10^{-6}] / 22 \times 10^{-6} = 295 \text{ mA}_{P-P} \quad (35)$$

The peak LED/inductor current is then estimated. This calculation uses the worst-case ripple current which occurs with three LEDs.

$$I_{L(PEAK)} = I_L + 0.5 \times \Delta i_{L(MAX)} \quad (36)$$

$$I_{L(PEAK)} = 1.5 + 0.5 \times 0.56 = 1.78\text{A} \quad (37)$$

In order to prevent inductor saturation the inductor's peak current rating must be above 1.8A. A 22 μH off-the-shelf inductor rated to 2.1A (peak) and 1.9A (average) with a DCR of 59 m Ω will be used.

8.3.3 USING AN OUTPUT CAPACITOR

This application does not require high frequency PWM dimming, allowing the use of an output capacitor to reduce the size and cost of the output inductor while still meeting the 10%_{P-P} target for LED ripple current. To select the proper output capacitor the equation from Buck Regulators with Output Capacitors is re-arranged to yield the following:

$$Z_C = \frac{\Delta i_F}{\Delta i_L - \Delta i_F} \times r_D \quad (38)$$

The dynamic resistance, r_D , of one LED can be calculated by taking the tangent line to the V_F vs. I_F curve in the LED datasheet. shows an example r_D calculation.

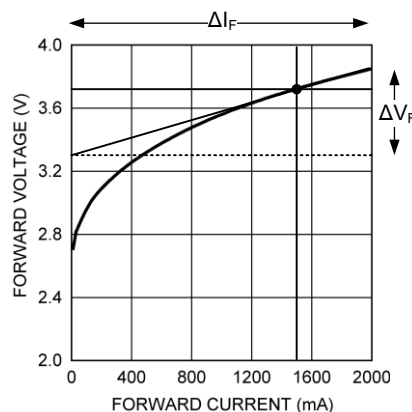

Calculating r_D from the V_F vs. I_F Curve

Design Example 1 (continued)

Extending the tangent line to the ends of the plot yields values for ΔV_F and ΔI_F of 0.7V and 2000 mA, respectively. Dynamic resistance is then:

$$r_D = \Delta V_F / \Delta I_F = 0.5V / 2A = 0.25\Omega \quad (39)$$

The most filtering (and therefore the highest output capacitance) is needed when r_D is lowest, which is when there is only one LED. Inductor ripple current with one LED is 478 mA_{P-P}. The required impedance of C_O is calculated:

$$Z_C = [0.15 / (0.478 - 0.15)] \times 0.35 = 0.114\Omega \quad (40)$$

A ceramic capacitor will be used and the required capacitance is selected based on the impedance at 362 kHz:

$$C_O = 1 / (2 \times \pi \times 0.16 \times 3.62 \times 10^5) = 3.9 \mu F \quad (41)$$

This calculation assumes that C_O will be a ceramic capacitor, and therefore impedance due to the equivalent series resistance (ESR) and equivalent series inductance (ESL) of the device is negligible. The closest 10% tolerance capacitor value is 4.7 μF . The capacitor used should be rated to 25V or more and have an X7R dielectric. Several manufacturers produce ceramic capacitors with these specifications in the 1206 case size. A typical value for ESR of 3 m Ω can be read from the curve of impedance vs. frequency in the product datasheet.

8.3.4 R_{SNS}

Using the expression for R_{SNS} :

$$R_{SNS} = 0.2 / I_F \quad (42)$$

$$R_{SNS} = 0.2 / 1.5 = 0.133\Omega \quad (43)$$

Sub-1 Ω resistors are available in both 1% and 5% tolerance. A 1%, 0.13 Ω device is the closest value, and a 0.33W, 1210 size device will handle the power dissipation of 290 mW. With the resistance selected, the average value of LED current is re-calculated to ensure that current is within the $\pm 5\%$ tolerance requirement. From the expression for average LED current:

$$I_F = 0.2 / 0.13 = 1.54A, 3\% \text{ above the target current} \quad (44)$$

8.3.5 INPUT CAPACITOR

Following the calculations from the Input Capacitor section, $\Delta V_{IN(MAX)}$ will be $24V \times 2\%_{P-P} = 480$ mV. The minimum required capacitance is calculated for the largest t_{ON} , corresponding to five LEDs:

$$C_{IN(MIN)} = (1.5 \times 1.5 \times 10^{-6}) / 0.48 = 4.7 \mu F \quad (45)$$

As with the output capacitor, this required value is low enough to use a ceramic capacitor, and again the effective capacitance will be lower than the rated value with 24V across C_{IN} . Reviewing plots of %C vs. DC Bias for several capacitors reveals that a 4.7 μF , 1812-size capacitor in X7R rated to 50V loses about 40% of its rated capacitance at 24V, hence two such caps are needed.

Input rms current is high in buck regulators, and the worst-case is when the duty cycle is 50%. Duty cycle in a buck regulator can be estimated as $D = V_O / V_{IN}$, and when this converter drives three LEDs the duty cycle will be nearly 50%.

$$I_{IN-RMS} = 1.5 \times \text{Sqrt}(0.5 \times 0.5) = 750 \text{ mA} \quad (46)$$

Ripple current ratings for 1812 size ceramic capacitors are typically higher than 2A, so two of them in parallel can tolerate more than enough for this design.

8.3.6 RECIRCULATING DIODE

The input voltage of 24V $\pm 5\%$ requires Schottky diodes with a reverse voltage rating greater than 30V. The next highest standard voltage rating is 40V. Selecting a 40V rated diode provides a large safety margin for the ringing of the switch node and also makes cross-referencing of diodes from different vendors easier.

The next parameters to be determined are the forward current rating and case size. The lower the duty cycle the more thermal stress is placed on the recirculating diode. When driving one LED the duty cycle can be estimated as:

$$D = 4.1 / 24 = 0.17 \quad (47)$$

The estimated average diode current is then:

$$I_D = (1 - 0.17) \times 1.54 = 1.28A \quad (48)$$

Design Example 1 (continued)

A 2A-rated diode will be used. To determine the proper case size, the dissipation and temperature rise in D1 can be calculated as shown in the Design Considerations section. V_D for a case size such as SMB in a 40V, 2A Schottky diode at 1.5A is approximately 0.4V and the θ_{JA} is 75°C/W. Power dissipation and temperature rise can be calculated as:

$$P_D = 1.28 \times 0.4 = 512 \text{ mW} \quad T_{RISE} = 0.51 \times 75 = 38^\circ\text{C} \quad (49)$$

8.3.7 C_B , C_C AND C_F

The bootstrap capacitor C_B should always be a 22 nF ceramic capacitors with X7R dielectric. A 25V rating is appropriate for all application circuits. The COMP pin capacitor C_C and the linear regulator filter capacitor C_F should always be 100 nF ceramic capacitors, also with X7R dielectric and a 25V ratings.

8.3.8 EFFICIENCY

To estimate the electrical efficiency of this example the power dissipation in each current carrying element can be calculated and summed. Electrical efficiency, η , should not be confused with the optical efficacy of the circuit, which depends upon the LEDs themselves. One calculation will be detailed for three LEDs in series, where $V_O = 11.8\text{V}$, and these calculations can be repeated for other numbers of LEDs.

Total output power, P_O , is calculated as:

$$P_O = I_F \times V_O = 1.54 \times 11.8 = 18.2\text{W} \quad (50)$$

Conduction loss, P_C , in the internal MOSFET:

$$P_C = (I_F^2 \times R_{DS(ON)}) \times D = (1.54^2 \times 0.75) \times 0.5 = 890 \text{ mW} \quad (51)$$

Gate charging and VCC loss, P_G , in the gate drive and linear regulator:

$$P_G = (I_{IN-OP} + f_{SW} \times Q_G) \times V_{IN} \quad P_G = (600 \times 10^{-6} + 5 \times 10^5 \times 9 \times 10^{-9}) \times 24 = 122 \text{ mW} \quad (52)$$

Switching loss, P_S , in the internal MOSFET:

$$P_S = 0.5 \times V_{IN} \times I_F \times (t_R + t_F) \times f_{SW} \quad P_S = 0.5 \times 24 \times 1.54 \times 40 \times 10^{-9} \times 5 \times 10^5 = 370 \text{ mW} \quad (53)$$

AC rms current loss, P_{CIN} , in the input capacitor:

$$P_{CIN} = I_{IN(rms)}^2 \times ESR = 0.75^2 \times 0.003 = 2 \text{ mW (negligible)} \quad (54)$$

DCR loss, P_L , in the inductor

$$P_L = I_F^2 \times DCR = 1.54^2 \times 0.06 = 142 \text{ mW} \quad (55)$$

Recirculating diode loss, $P_D = (1 - 0.5) \times 1.54 \times 0.4 = 300 \text{ mW}$

Current Sense Resistor Loss, $P_{SNS} = 293 \text{ mW}$

Electrical efficiency, $\eta = P_O / (P_O + \text{Sum of all loss terms}) = 18.2 / (18.2 + 2.1) = 89\%$

Temperature Rise in the LM3406 IC is calculated as:

$$T_{LM3406} = (P_C + P_G + P_S) \times \theta_{JA} = (0.89 + 0.122 + 0.37) \times 50 = 69^\circ\text{C} \quad (56)$$

8.4 Design Example 2

The second example circuit uses the LM3406 to drive a single white LED at 1.5A $\pm 10\%$ with a ripple current of 20%_{p-p} in a typical 12V automotive electrical system. The two-wire dimming function will be employed in order to take advantage of the legacy 'theater dimming' method which dims and brightens the interior lights of automobiles by chopping the input voltage with a 200Hz PWM signal. As with the previous example, the typical V_F of a white LED is 3.9V, and with the current sense voltage of 0.2V the total output voltage will be 4.1V. The LED driver must operate to specifications over an input range of 9V to 16V as well as operating without suffering damage at 28V for two minutes (the 'double battery jump-start' test) and for 300 ms at 40V (the 'load-dump' test). The LED driver must also be able to operate without suffering damage at inputs as low as 6V to satisfy the 'cold crank' tests. A complete bill of materials can be found in [Table 2](#) at the end of this datasheet.

Design Example 2 (continued)

The minimum inductance required to ensure a ripple current of 600 mA_{P-P} or less is calculated at V_{IN-MAX}:

$$L = \frac{V_{IN} - V_O}{\Delta i_L} \times t_{ON} \quad (66)$$

$$L_{MIN} = [(16 - 4.1) \times 6.5 \times 10^{-7}] / (0.6) = 12.9 \mu\text{H} \quad (67)$$

The closest standard inductor value is 15 μH . The average current rating should be greater than 1.5A to prevent overheating in the inductor. Inductor current ripple should be calculated for V_{IN-MIN} and V_{IN-MAX}:

$$\Delta i_{L(VMIN)} = [(9 - 4.1) \times 6.5 \times 10^{-7}] / 15 \times 10^{-6} = 357 \text{ mA}_{P-P} \quad (68)$$

$$\Delta i_{L(VMAX)} = [(16 - 4.1) \times 1.09 \times 10^{-6}] / 15 \times 10^{-6} = 516 \text{ mA}_{P-P} \quad (69)$$

The peak LED/inductor current is then estimated. This calculation uses the worst-case ripple current which occurs at V_{IN-MAX}.

$$I_{L(PEAK)} = I_L + 0.5 \times \Delta i_{L(MAX)} \quad (70)$$

$$I_{L(PEAK)} = 1.5 + 0.5 \times 0.516 = 1.76\text{A} \quad (71)$$

In order to prevent inductor saturation the inductor's peak current rating must be above 1.8A. A 15 μH off-the-shelf inductor rated to 2.4A (peak) and 2.2A (average) with a DCR of 47 m Ω will be used.

8.4.3 USING AN OUTPUT CAPACITOR

This application does not require high frequency PWM dimming, allowing the use of an output capacitor to reduce the size and cost of the output inductor while still meeting the 20%_{P-P} (300 mA) target for LED ripple current. To select the proper output capacitor the equation from Buck Regulators with Output Capacitors is rearranged to yield the following:

$$Z_C = \frac{\Delta i_F}{\Delta i_L - \Delta i_F} \times r_D \quad (72)$$

The dynamic resistance, r_D, of one LED can be calculated by taking the tangent line to the V_F vs. I_F curve in the LED datasheet. shows an example r_D calculation.

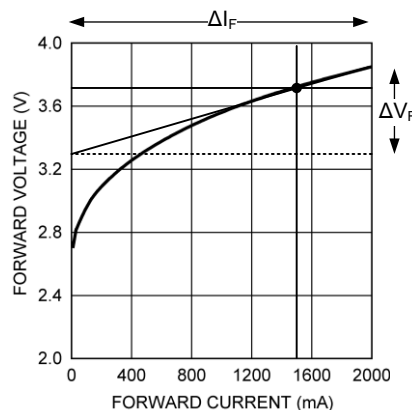

Calculating r_D from the V_F vs. I_F Curve

Extending the tangent line to the ends of the plot yields values for ΔV_F and ΔI_F of 0.7V and 2000 mA, respectively. Dynamic resistance is then:

$$r_D = \Delta V_F / \Delta I_F = 0.5\text{V} / 2\text{A} = 0.25\Omega \quad (73)$$

The most filtering (and therefore the highest output capacitance) is needed when Δi_L is highest, which occurs at V_{IN-MAX}. Inductor ripple current with one LED is 516 mA_{P-P}. The required impedance of C_O is calculated:

$$Z_C = [0.3 / (0.516 - 0.3)] \times 0.35 = 0.35\Omega \quad (74)$$

A ceramic capacitor will be used and the required capacitance is selected based on the impedance at 440 kHz:

$$C_O = 1 / (2 \times \pi \times 0.49 \times 4.4 \times 10^5) = 1.03 \mu\text{F} \quad (75)$$

Design Example 2 (continued)

This calculation assumes that C_O will be a ceramic capacitor, and therefore impedance due to the equivalent series resistance (ESR) and equivalent series inductance (ESL) of the device is negligible. The closest 10% tolerance capacitor value is 1.5 μF . The capacitor used should have an X7R dielectric and should be rated to 50V. The high voltage rating ensures that C_O will not be damaged if the LED fails open circuit and a load dump occurs. Several manufacturers produce ceramic capacitors with these specifications in the 1206 case size. With only 4V of DC bias a 50V rated ceramic capacitor will have better than 90% of its rated capacitance, which is more than enough for this design.

8.4.4 R_{SNS}

Using the expression for R_{SNS} :

$$R_{\text{SNS}} = 0.2 / I_F \quad (76)$$

$$R_{\text{SNS}} = 0.2 / 1.5 = 0.133\Omega \quad (77)$$

Sub-1 Ω resistors are available in both 1% and 5% tolerance. A 1%, 0.13 Ω device is the closest value, and a 0.33W, 1210 size device will handle the power dissipation of 290 mW. With the resistance selected, the average value of LED current is re-calculated to ensure that current is within the $\pm 5\%$ tolerance requirement. From the expression for average LED current:

$$I_F = 0.2 / 0.13 = 1.54\text{A}, 3\% \text{ above the target current} \quad (78)$$

8.4.5 INPUT CAPACITOR

Controlling input ripple current and voltage is critical in automotive applications where stringent conducted electromagnetic interference tests are required. $\Delta V_{\text{IN(MAX)}}$ will be limited to 300 mV_{P-P} or less. The minimum required capacitance is calculated for the largest t_{ON} , 1090 ns, which occurs at the minimum input voltage. Using the equations from the Input Capacitors section:

$$C_{\text{IN(MIN)}} = (1.5 \times 1.09 \times 10^{-6}) / 0.3 = 5.5 \mu\text{F} \quad (79)$$

As with the output capacitor, this required value is low enough to use a ceramic capacitor, and again the effective capacitance will be lower than the rated value with 16V across C_{IN} . Reviewing plots of %C vs. DC Bias for several capacitors reveals that a 3.3 μF , 1210-size capacitor in X7R rated to 50V loses about 22% of its rated capacitance at 16V, hence two such caps are needed.

Input rms current is high in buck regulators, and the worst-case is when the duty cycle is 50%. Duty cycle in a buck regulator can be estimated as $D = V_O / V_{\text{IN}}$, and when V_{IN} drops to 9V the duty cycle will be nearly 50%.

$$I_{\text{IN-RMS}} = 1.5 \times \text{Sqrt}(0.5 \times 0.5) = 750 \text{ mA} \quad (80)$$

Ripple current ratings for 1210 size ceramic capacitors are typically higher than 2A, so two of them in parallel can tolerate more than enough for this design.

8.4.6 RECIRCULATING DIODE

To survive an input voltage transient of 40V the Schottky diode must be rated to a higher voltage. The next highest standard voltage rating is 60V. Selecting a 60V rated diode provides a large safety margin for the ringing of the switch node and also makes cross-referencing of diodes from different vendors easier.

The next parameters to be determined are the forward current rating and case size. The lower the duty cycle the more thermal stress is placed on the recirculating diode. When driving one LED the duty cycle can be estimated as:

$$D = 4.1 / 13.8 = 0.3 \quad (81)$$

The estimated average diode current is then:

$$I_D = (1 - 0.3) \times 1.54 = 1.1\text{A} \quad (82)$$

A 2A-rated diode will be used. To determine the proper case size, the dissipation and temperature rise in D1 can be calculated as shown in the Design Considerations section. V_D for a case size such as SMB in a 60V, 2A Schottky diode at 1.5A is approximately 0.4V and the θ_{JA} is 75°C/W. Power dissipation and temperature rise can be calculated as:

$$P_D = 1.1 \times 0.4 = 440 \text{ mW} \quad T_{\text{RISE}} = 0.44 \times 75 = 33^\circ\text{C} \quad (83)$$

Design Example 2 (continued)

8.4.7 C_B , C_C AND C_F

The bootstrap capacitor C_B should always be a 22 nF ceramic capacitors with X7R dielectric. A 25V rating is appropriate for all application circuits. The COMP pin capacitor C_C and the linear regulator filter capacitor C_F should always be 100 nF ceramic capacitors, also with X7R dielectric and a 25V ratings.

8.4.8 EFFICIENCY

To estimate the electrical efficiency of this example the power dissipation in each current carrying element can be calculated and summed. One calculation will be detailed for the nominal input voltage of 13.8V, and these calculations can be repeated for other numbers of LEDs.

Total output power, P_O , is calculated as:

$$P_O = I_F \times V_O = 1.54 \times 4.1 = 6.3\text{W} \quad (84)$$

Conduction loss, P_C , in the internal MOSFET:

$$P_C = (I_F^2 \times R_{\text{DS(on)}}) \times D = (1.54^2 \times 0.75) \times 0.3 = 530 \text{ mW} \quad (85)$$

Gate charging and VCC loss, P_G , in the gate drive and linear regulator:

$$P_G = (I_{\text{IN-OP}} + f_{\text{SW}} \times Q_G) \times V_{\text{IN}} \quad P_G = (600 \times 10^{-6} + 4.5 \times 10^5 \times 9 \times 10^{-9}) \times 13.8 = 64 \text{ mW} \quad (86)$$

Switching loss, P_S , in the internal MOSFET:

$$P_S = 0.5 \times V_{\text{IN}} \times I_F \times (t_R + t_F) \times f_{\text{SW}} \quad P_S = 0.5 \times 13.8 \times 1.54 \times 40 \times 10^{-9} \times 4.5 \times 10^5 = 190 \text{ mW} \quad (87)$$

AC rms current loss, P_{CIN} , in the input capacitor:

$$P_{\text{CIN}} = I_{\text{IN(rms)}}^2 \times \text{ESR} = 0.75^2 \times 0.003 = 2 \text{ mW (negligible)} \quad (88)$$

DCR loss, P_L , in the inductor

$$P_L = I_F^2 \times \text{DCR} = 1.54^2 \times 0.05 = 120 \text{ mW} \quad (89)$$

Recirculating diode loss, $P_D = (1 - 0.3) \times 1.54 \times 0.4 = 430 \text{ mW}$

Current Sense Resistor Loss, $P_{\text{SNS}} = 293 \text{ mW}$

Electrical efficiency, $\eta = P_O / (P_O + \text{Sum of all loss terms}) = 6.3 / (6.3 + 1.6) = 80\%$

Temperature Rise in the LM3406 IC is calculated as:

$$T_{\text{LM3406}} = (P_C + P_G + P_S) \times \theta_{\text{JA}} = (0.53 + 0.06 + 0.19) \times 50 = 39^\circ\text{C} \quad (90)$$

8.5 Thermal Considerations During Input Transients

The error amplifier of the LM3406 ensures that average LED current is controlled even at the transient load-dump voltage of 40V, leaving thermal considerations as a primary design consideration during high voltage transients. A review of the operating conditions at an input of 40V is still useful to make sure that the LM3406 die temperature is not exceeded. Switching frequency drops to 325 kHz, the on-time drops to 350 ns, and the duty cycle drops to 0.12. Repeating the calculations for conduction, gate charging and switching loss leads to a total internal loss of 731 mW, and hence a die temperature rise of 37°C. The LM3406 should operate properly even if the ambient temperature is as high a 85°C.

8.6 Layout Considerations

The performance of any switching converter depends as much upon the layout of the PCB as the component selection. The following guidelines will help the user design a circuit with maximum rejection of outside EMI and minimum generation of unwanted EMI.

8.6.1 COMPACT LAYOUT

Parasitic inductance can be reduced by keeping the power path components close together and keeping the area of the loops that high currents travel small. Short, thick traces or copper pours (shapes) are best. In particular, the switch node (where L1, D1, and the SW pin connect) should be just large enough to connect all three components without excessive heating from the current it carries. The LM3406 family operates in two distinct cycles whose high current paths are shown in :

Layout Considerations (continued)

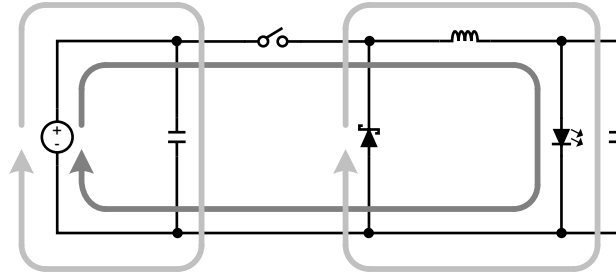

Buck Converter Current Loops

The dark grey, inner loop represents the high current path during the MOSFET on-time. The light grey, outer loop represents the high current path during the off-time.

8.6.2 GROUND PLANE AND SHAPE ROUTING

The diagram of is also useful for analyzing the flow of continuous current vs. the flow of pulsating currents. The circuit paths with current flow during both the on-time and off-time are considered to be continuous current, while those that carry current during the on-time or off-time only are pulsating currents. Preference in routing should be given to the pulsating current paths, as these are the portions of the circuit most likely to emit EMI. The ground plane of a PCB is a conductor and return path, and it is susceptible to noise injection just as any other circuit path. The continuous current paths on the ground net can be routed on the system ground plane with less risk of injecting noise into other circuits. The path between the input source and the input capacitor and the path between the recirculating diode and the LEDs/current sense resistor are examples of continuous current paths. In contrast, the path between the recirculating diode and the input capacitor carries a large pulsating current. This path should be routed with a short, thick shape, preferably on the component side of the PCB. Do not place any vias near the anode of Schottky diode. Instead, multiple vias in parallel should be used right at the pad of the input capacitor to connect the component side shapes to the ground plane. A second pulsating current loop that is often ignored is the gate drive loop formed by the SW and BOOT pins and capacitor C_B . To minimize this loop and the EMI it generates, keep C_B close to the SW and BOOT pins.

8.6.3 CURRENT SENSING

The CS pin is a high-impedance input, and the loop created by R_{SNS} , R_Z (if used), the CS pin and ground should be made as small as possible to maximize noise rejection. R_{SNS} should therefore be placed as close as possible to the CS and GND pins of the IC.

8.6.4 REMOTE LED ARRAYS

In some applications the LED or LED array can be far away (several inches or more) from the LM3406 family, or on a separate PCB connected by a wiring harness. When an output capacitor is used and the LED array is large or separated from the rest of the converter, the output capacitor should be placed close to the LEDs to reduce the effects of parasitic inductance on the AC impedance of the capacitor. The current sense resistor should remain on the same PCB, close to the LM3406 family.

Remote LED arrays and high speed dimming with a parallel FET must be treated with special care. The parallel dimming FET should be placed on the same board and/or heatsink as the LEDs to minimize the loop area between them, as the switching of output current by the parallel FET produces a pulsating current just like the switching action of the LM3406's internal power FET and the Schottky diode. shows the path that the inductor current takes through the LED or through the dimming FET. To minimize the EMI from parallel FET dimming the parasitic inductance of the loop formed by the LED and the dimming FET (where only the dark grey arrows appear) should be reduced as much as possible. Parasitic inductance of a loop is mostly controlled by the loop area, hence making this loop as physically small (short) as possible will reduce the inductance.

Layout Considerations (continued)

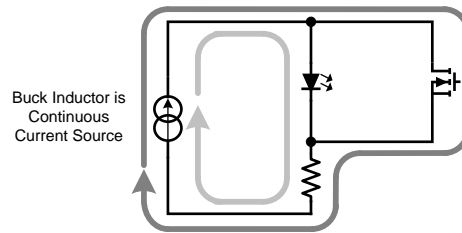

Parallel FET Dimming Current Loops

Table 1. BOM for Design Example 1

ID	Part Number	Type	Size	Parameters	Qty	Vendor
U1	LM3406	LED Driver	eTSSOP-14	42V, 2A	1	NSC
L1	SLF10145T-220M1R-PF	Inductor	10 x 10 x 4.5mm	22 μ H, 1.9A, 59 m Ω	1	TDK
D1	CMSH2-40	Schottky Diode	SMB	40V, 2A	1	Central Semi
Cc, Cf	VJ0603Y104KXXAT	Capacitor	0603	100 nF 10%	2	Vishay
Cb	VJ0603Y223KXXAT	Capacitor	0603	22 nF 10%	1	Vishay
Cin1 Cin2	C4532X7R1H475M	Capacitor	1812	4.7 μ F, 50V	2	TDK
Co	C2012X7R1E105M	Capacitor	0805	1.0 μ F, 25V	1	TDK
Rsns	ERJ14RQFR13V	Resistor	1210	0.13 Ω 1%	1	Panasonic
Ron	CRCW08051433F	Resistor	0805	143 k Ω 1%	1	Vishay

Table 2. BOM for Design Example 2

ID	Part Number	Type	Size	Parameters	Qty	Vendor
U1	LM3406	LED Driver	eTSSOP-14	42V, 2A	1	NSC
L1	SLF10145T-150M2R2-P	Inductor	10 x 10 x 4.5mm	15 μ H, 2.2A, 47 m Ω	1	TDK
D1	CMSH2-60	Schottky Diode	SMB	60V, 2A	1	Central Semi
Cc, Cf	VJ0603Y104KXXAT	Capacitor	0603	100 nF 10%	2	Vishay
Cb	VJ0603Y223KXXAT	Capacitor	0603	22 nF 10%	1	Vishay
Cin1 Cin2	C3225X7R1H335M	Capacitor	1210	3.3 μ F, 50V	2	TDK
Co	C3216X7R1H105M	Capacitor	1206	0.15 μ F, 50V	1	TDK
Rsns	ERJ14RQFR13V	Resistor	1210	0.13 Ω 1%	1	Panasonic
Ron	CRCW08051243F	Resistor	0805	124 k Ω 1%	1	Vishay
Rpd	CRCW08051002F	Resistor	0805	10 k Ω 1%	1	Vishay

Table 3. Bill of Materials for Efficiency Curves

ID	Part Number	Type	Size	Parameters	Qty	Vendor
U1	LM3406	Buck LED Driver	eTSSOP-14	42V, 1.5A	1	NSC
Q1	Si3458DV	N-MOSFET	SOT23-6	60V, 2.8A	1	Vishay
D1	CMSH2-60M	Schottky Diode	SMA	60V, 2A	1	Central Semi
L1	VLF10045T-330M2R3	Inductor	10 x 10 x 4.5mm	33 μ H, 2.3A, 70 m Ω	1	TDK
Cin1 Cin2	C4532X7R1H685M	Capacitor	1812	6.8 μ F, 50V	2	TDK
Co	C3216X7R1H474M	Capacitor	1206	470 nF, 50V	1	TDK
Cf, Cc	VJ0603Y104KXXAT	Capacitor	0603	100 nF 10%	2	Vishay

Table 3. Bill of Materials for Efficiency Curves (continued)

ID	Part Number	Type	Size	Parameters	Qty	Vendor
Cb	VJ0603Y223KXXAT	Capacitor	0603	22 nF 10%	1	Vishay
R3.5	ERJ6RQFR56V	Resistor	0805	0.56Ω 1%	1	Panasonic
R.7	ERJ6RQFR62V	Resistor	0805	0.62Ω 1%	1	Panasonic
R1	ERJ6RQFR30V	Resistor	0805	0.3Ω 1%	1	Panasonic
R1.5	ERJ6RQFR16V	Resistor	0805	0.16Ω 1%	1	Panasonic
Ron	CRCW08051433F	Resistor	0805	143kΩ 1%	1	Vishay
Rpd Rout	CRCW06031002F	Resistor	0603	10 kΩ 1%	2	Vishay
OFF* DIM1 DIM2	160-1512	Terminal	0.062"		3	Cambion
VIN GND CS/LED- Vo/LED+	160-1026	Terminal	0.094"		2	Cambion

8.7 APPENDIX

The following expressions provide the best accuracy for users who wish to create computer-based simulations or circuit calculators:

$$t_{ON} = \frac{9.92 \times 10^{-12} \times (V_O + 0.65) \times R_{ON}}{V_{IN} - 1.5} + 1.75 \times 10^{-7} \quad (91)$$

$$R_{ON} = \frac{(D - f_{SW} \times 1.75 \times 10^{-7}) \times (V_{IN} - 1.5)}{9.92 \times 10^{-12} \times f_{SW} \times (V_O + 0.65)} \quad (92)$$

$$f_{SW} = \frac{D \times (V_{IN} - 1.5)}{9.92 \times 10^{-12} \times (V_O + 0.65) \times R_{ON} + 1.75 \times 10^{-7} \times (V_{IN} - 1.5)} \quad (93)$$

9 Revision History

NOTE: Page numbers for previous revisions may differ from page numbers in the current version.

Changes from Revision D (April 2013) to Revision E	Page
-----------------------------------------------------------	-------------

- Added availability of LM3406HV-Q1, the automotive grade device throughout the data sheet. 1
-

Changes from Revision C (May 2013) to Revision D	Page
---------------------------------------------------------	-------------

- Changed layout of National Data Sheet to TI format 31
-

PACKAGING INFORMATION

Orderable Device	Status (1)	Package Type	Package Drawing	Pins	Package Qty	Eco Plan (2)	Lead finish/ Ball material (6)	MSL Peak Temp (3)	Op Temp (°C)	Device Marking (4/5)	Samples
LM3406HVMH/NOPB	ACTIVE	HTSSOP	PWP	14	94	RoHS & Green	SN	Level-1-260C-UNLIM	-40 to 125	LM3406 HVMH	Samples
LM3406HVMHX/NOPB	ACTIVE	HTSSOP	PWP	14	2500	RoHS & Green	SN	Level-1-260C-UNLIM	-40 to 125	LM3406 HVMH	Samples
LM3406HVQMQH1	ACTIVE	HTSSOP	PWP	14	94	RoHS & Green	SN	Level-1-260C-UNLIM	-40 to 150	LM3406Q HVMH	Samples
LM3406HVQMHXQ1	ACTIVE	HTSSOP	PWP	14	2500	RoHS & Green	SN	Level-1-260C-UNLIM	-40 to 150	LM3406Q HVMH	Samples
LM3406MH/NOPB	ACTIVE	HTSSOP	PWP	14	94	RoHS & Green	SN	Level-1-260C-UNLIM	-40 to 125	LM3406 MH	Samples
LM3406MHX/NOPB	ACTIVE	HTSSOP	PWP	14	2500	RoHS & Green	SN	Level-1-260C-UNLIM	-40 to 125	LM3406 MH	Samples

(1) The marketing status values are defined as follows:

ACTIVE: Product device recommended for new designs.

LIFEBUY: TI has announced that the device will be discontinued, and a lifetime-buy period is in effect.

NRND: Not recommended for new designs. Device is in production to support existing customers, but TI does not recommend using this part in a new design.

PREVIEW: Device has been announced but is not in production. Samples may or may not be available.

OBSELETE: TI has discontinued the production of the device.

(2) **RoHS:** TI defines "RoHS" to mean semiconductor products that are compliant with the current EU RoHS requirements for all 10 RoHS substances, including the requirement that RoHS substance do not exceed 0.1% by weight in homogeneous materials. Where designed to be soldered at high temperatures, "RoHS" products are suitable for use in specified lead-free processes. TI may reference these types of products as "Pb-Free".

RoHS Exempt: TI defines "RoHS Exempt" to mean products that contain lead but are compliant with EU RoHS pursuant to a specific EU RoHS exemption.

Green: TI defines "Green" to mean the content of Chlorine (Cl) and Bromine (Br) based flame retardants meet JS709B low halogen requirements of <=1000ppm threshold. Antimony trioxide based flame retardants must also meet the <=1000ppm threshold requirement.

(3) MSL, Peak Temp. - The Moisture Sensitivity Level rating according to the JEDEC industry standard classifications, and peak solder temperature.

(4) There may be additional marking, which relates to the logo, the lot trace code information, or the environmental category on the device.

(5) Multiple Device Markings will be inside parentheses. Only one Device Marking contained in parentheses and separated by a "-" will appear on a device. If a line is indented then it is a continuation of the previous line and the two combined represent the entire Device Marking for that device.

⁽⁶⁾ Lead finish/Ball material - Orderable Devices may have multiple material finish options. Finish options are separated by a vertical ruled line. Lead finish/Ball material values may wrap to two lines if the finish value exceeds the maximum column width.

Important Information and Disclaimer:The information provided on this page represents TI's knowledge and belief as of the date that it is provided. TI bases its knowledge and belief on information provided by third parties, and makes no representation or warranty as to the accuracy of such information. Efforts are underway to better integrate information from third parties. TI has taken and continues to take reasonable steps to provide representative and accurate information but may not have conducted destructive testing or chemical analysis on incoming materials and chemicals. TI and TI suppliers consider certain information to be proprietary, and thus CAS numbers and other limited information may not be available for release.

In no event shall TI's liability arising out of such information exceed the total purchase price of the TI part(s) at issue in this document sold by TI to Customer on an annual basis.

OTHER QUALIFIED VERSIONS OF LM3406HV, LM3406HV-Q1 :

- Catalog: [LM3406HV](#)
- Automotive: [LM3406HV-Q1](#)

NOTE: Qualified Version Definitions:

- Catalog - TI's standard catalog product
- Automotive - Q100 devices qualified for high-reliability automotive applications targeting zero defects

TAPE AND REEL INFORMATION

QUADRANT ASSIGNMENTS FOR PIN 1 ORIENTATION IN TAPE



*All dimensions are nominal

Device	Package Type	Package Drawing	Pins	SPQ	Reel Diameter (mm)	Reel Width W1 (mm)	A0 (mm)	B0 (mm)	K0 (mm)	P1 (mm)	W (mm)	Pin1 Quadrant
LM3406HVMHX/NOPB	HTSSOP	PWP	14	2500	330.0	12.4	6.95	5.6	1.6	8.0	12.0	Q1
LM3406HVQMHXQ1	HTSSOP	PWP	14	2500	330.0	12.4	6.95	5.6	1.6	8.0	12.0	Q1
LM3406MHX/NOPB	HTSSOP	PWP	14	2500	330.0	12.4	6.95	5.6	1.6	8.0	12.0	Q1

TAPE AND REEL BOX DIMENSIONS

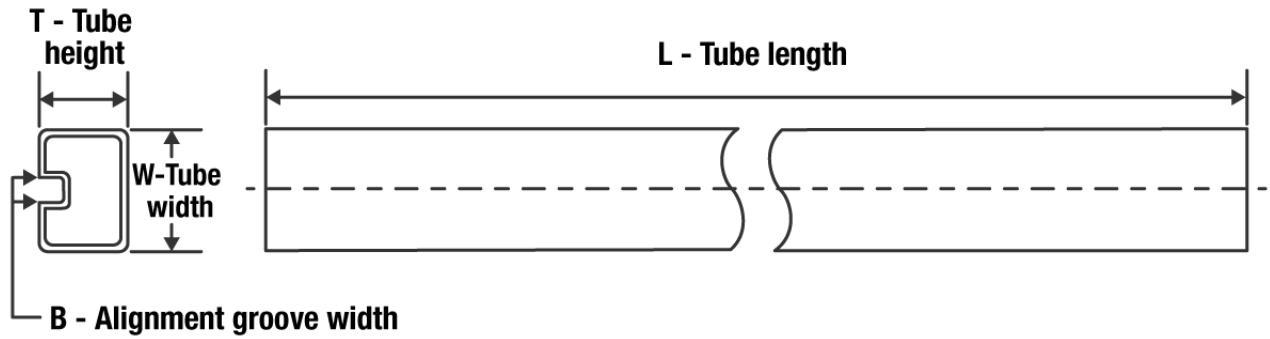

*All dimensions are nominal

Device	Package Type	Package Drawing	Pins	SPQ	Length (mm)	Width (mm)	Height (mm)
LM3406HVMHX/NOPB	HTSSOP	PWP	14	2500	367.0	367.0	35.0
LM3406HVQMHXQ1	HTSSOP	PWP	14	2500	367.0	367.0	35.0
LM3406MHX/NOPB	HTSSOP	PWP	14	2500	367.0	367.0	35.0

TUBE

*All dimensions are nominal

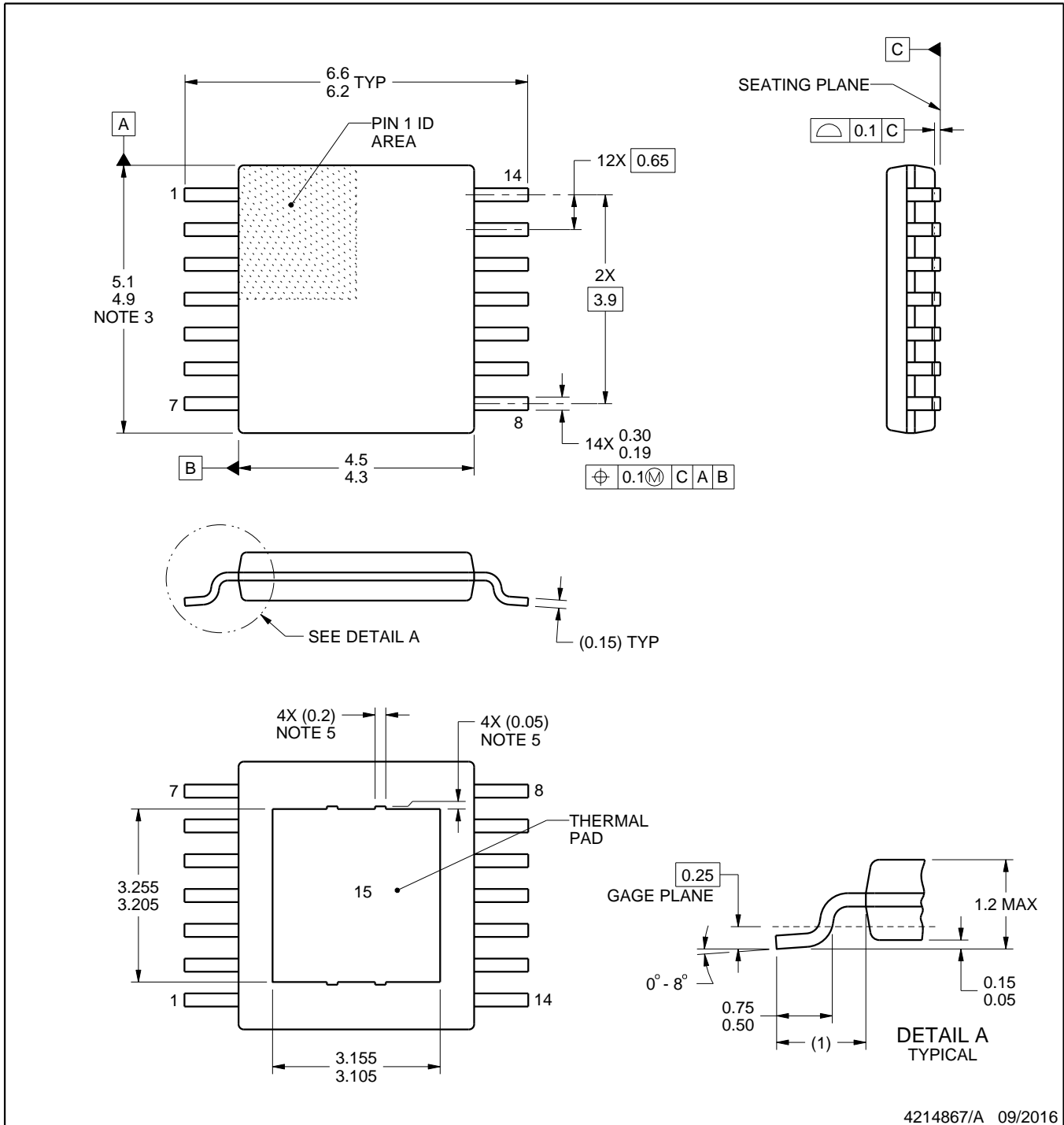
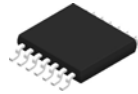
Device	Package Name	Package Type	Pins	SPQ	L (mm)	W (mm)	T (μm)	B (mm)
LM3406HVMH/NOPB	PWP	HTSSOP	14	94	495	8	2514.6	4.06
LM3406HVQMHQ1	PWP	HTSSOP	14	94	495	8	2514.6	4.06
LM3406MH/NOPB	PWP	HTSSOP	14	94	495	8	2514.6	4.06



4214867/A 09/2016

NOTES:

PowerPAD is a trademark of Texas Instruments.

1. All linear dimensions are in millimeters. Any dimensions in parenthesis are for reference only. Dimensioning and tolerancing per ASME Y14.5M.
2. This drawing is subject to change without notice.
3. This dimension does not include mold flash, protrusions, or gate burrs. Mold flash, protrusions, or gate burrs shall not exceed 0.15 mm per side.
4. Reference JEDEC registration MO-153.
5. Features may differ and may not be present.

EXAMPLE BOARD LAYOUT

PWP0014A

PowerPAD™ TSSOP - 1.2 mm max height

PLASTIC SMALL OUTLINE

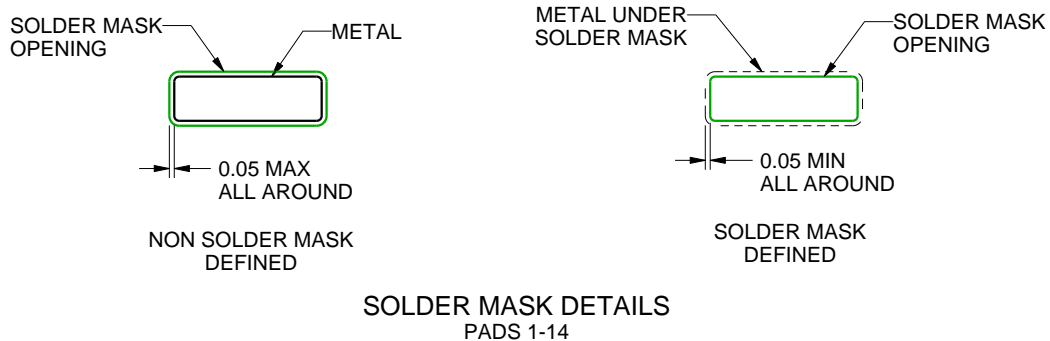
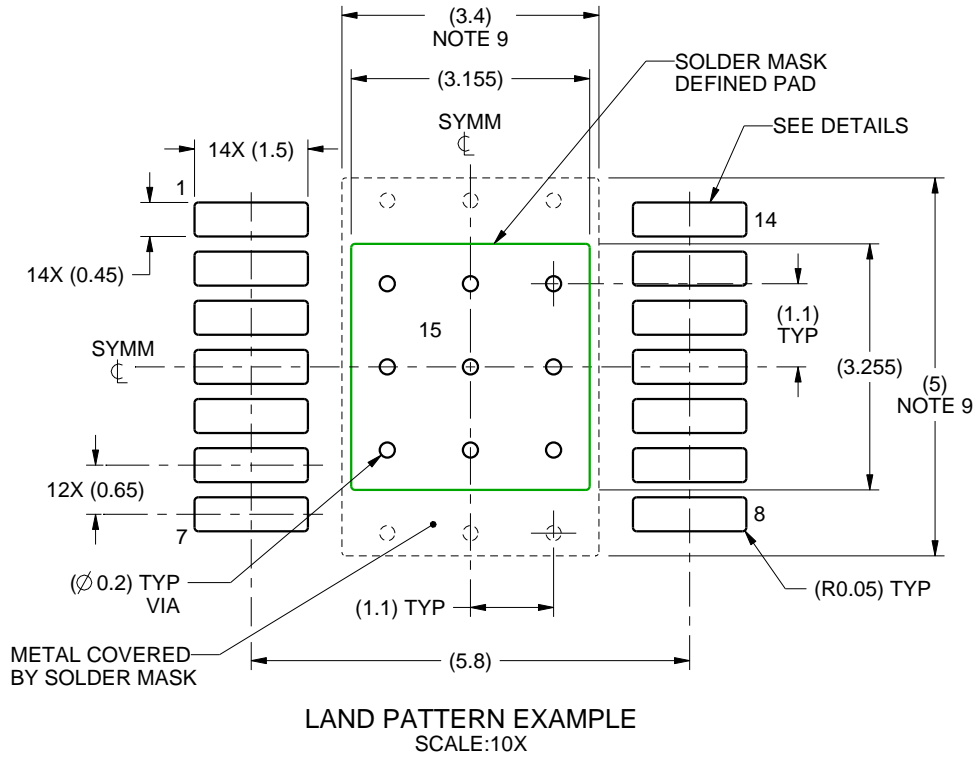

4214867/A 09/2016

NOTES: (continued)

6. Publication IPC-7351 may have alternate designs.
7. Solder mask tolerances between and around signal pads can vary based on board fabrication site.
8. This package is designed to be soldered to a thermal pad on the board. For more information, see Texas Instruments literature numbers SLMA002 (www.ti.com/lit/slma002) and SLMA004 (www.ti.com/lit/slma004).
9. Size of metal pad may vary due to creepage requirement.

EXAMPLE STENCIL DESIGN

PWP0014A

PowerPAD™ TSSOP - 1.2 mm max height

PLASTIC SMALL OUTLINE

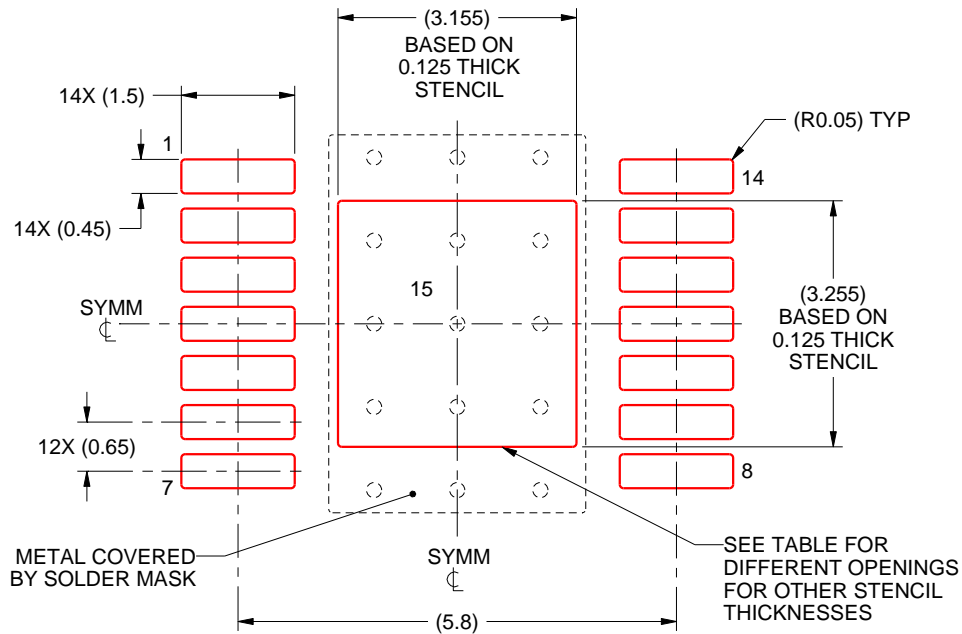

SOLDER PASTE EXAMPLE
 EXPOSED PAD
 100% PRINTED SOLDER COVERAGE BY AREA
 SCALE:10X

STENCIL THICKNESS	SOLDER STENCIL OPENING
0.1	3.53 X 3.64
0.125	3.155 X 3.255 (SHOWN)
0.15	2.88 X 2.97
0.175	2.67 X 2.75

4214867/A 09/2016

NOTES: (continued)

10. Laser cutting apertures with trapezoidal walls and rounded corners may offer better paste release. IPC-7525 may have alternate design recommendations.
11. Board assembly site may have different recommendations for stencil design.

IMPORTANT NOTICE AND DISCLAIMER

TI PROVIDES TECHNICAL AND RELIABILITY DATA (INCLUDING DATA SHEETS), DESIGN RESOURCES (INCLUDING REFERENCE DESIGNS), APPLICATION OR OTHER DESIGN ADVICE, WEB TOOLS, SAFETY INFORMATION, AND OTHER RESOURCES "AS IS" AND WITH ALL FAULTS, AND DISCLAIMS ALL WARRANTIES, EXPRESS AND IMPLIED, INCLUDING WITHOUT LIMITATION ANY IMPLIED WARRANTIES OF MERCHANTABILITY, FITNESS FOR A PARTICULAR PURPOSE OR NON-INFRINGEMENT OF THIRD PARTY INTELLECTUAL PROPERTY RIGHTS.

These resources are intended for skilled developers designing with TI products. You are solely responsible for (1) selecting the appropriate TI products for your application, (2) designing, validating and testing your application, and (3) ensuring your application meets applicable standards, and any other safety, security, regulatory or other requirements.

These resources are subject to change without notice. TI grants you permission to use these resources only for development of an application that uses the TI products described in the resource. Other reproduction and display of these resources is prohibited. No license is granted to any other TI intellectual property right or to any third party intellectual property right. TI disclaims responsibility for, and you will fully indemnify TI and its representatives against, any claims, damages, costs, losses, and liabilities arising out of your use of these resources.



TI's products are provided subject to [TI's Terms of Sale](#) or other applicable terms available either on ti.com or provided in conjunction with such TI products. TI's provision of these resources does not expand or otherwise alter TI's applicable warranties or warranty disclaimers for TI products.

TI objects to and rejects any additional or different terms you may have proposed.

Mailing Address: Texas Instruments, Post Office Box 655303, Dallas, Texas 75265
Copyright © 2022, Texas Instruments Incorporated

Looking for pricing, stock, or lifecycle information?

Click below to explore more details on WIN SOURCE:

-  [View LM3406HVMHX/NOPB on WIN SOURCE](#)
-  [Texas Instruments](#) Information

Optimize Your Supply Chain with WIN SOURCE Solutions

-  Global Sourcing Solution
-  Obsolete Management
-  Cost Control Management
-  Shortage Management
-  Alternative Solution
-  Excess Inventory Management