



**THE DATASHEET OF  
LM3485MMX/NOPB**



## LM3485 Hysteretic PFET Buck Controller

### 1 Features

- Easy-to-Use Control Methodology
- No Control-Loop Compensation Required
- 4.5-V to 35-V Wide Input Range
- 1.242-V to  $V_{IN}$  Adjustable Output Range
- High Efficiency 93%
- $\pm 1.3\%$  ( $\pm 2\%$  Over Temp) Internal Reference
- 100% Duty Cycle
- Maximum Operating Frequency > 1 MHz
- Current Limit Protection

### 2 Applications

- Set-Top Box
- DSL or Cable Modem
- PC/IA
- Auto PC
- TFT Monitor
- Battery-Powered Portable Applications
- Distributed Power Systems
- Always On Power

### 3 Description

The LM3485 is a high-efficiency PFET switching regulator controller that can be used to quickly and easily develop a small, low-cost, switching buck regulator for a wide range of applications. The hysteretic control architecture provides for simple design without any control-loop stability concerns using a wide variety of external components. The PFET architecture also allows for low component count as well as ultralow dropout, 100% duty cycle operation. Another benefit is high efficiency operation at light loads without an increase in output ripple.

Current limit protection is provided by measuring the voltage across the  $R_{DS(ON)}$  of the PFET, thus eliminating the need for a sense resistor. The cycle-by-cycle current limit can be adjusted with a single resistor, ensuring safe operation over a range of output currents.

#### Device Information<sup>(1)</sup>

PART NUMBER	PACKAGE	BODY SIZE (NOM)
LM3485	VSSOP (8)	3.0 mm x 3.0 mm

(1) For all available packages, see the orderable addendum at the end of the data sheet.

#### Typical Application Circuit

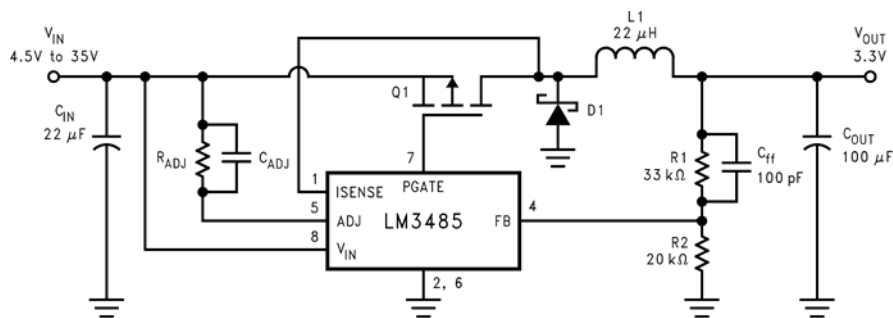

## Table of Contents

<b>1 Features</b> ..... 1 <b>2 Applications</b> ..... 1 <b>3 Description</b> ..... 1 <b>4 Revision History</b> ..... 2 <b>5 Pin Configuration and Functions</b> ..... 3 <b>6 Specifications</b> ..... 4 6.1 Absolute Maximum Ratings ..... 4 6.2 ESD Ratings..... 4 6.3 Recommended Operating Conditions ..... 4 6.4 Thermal Information ..... 4 6.5 Electrical Characteristics..... 5 6.6 Typical Characteristics ..... 6 <b>7 Detailed Description</b> ..... 10 7.1 Overview ..... 10 7.2 Functional Block Diagram ..... 10 7.3 Feature Description..... 10	7.4 Device Functional Modes..... 14 <b>8 Application and Implementation</b> ..... 15 8.1 Application Information..... 15 8.2 Typical Application ..... 15 <b>9 Power Supply Recommendations</b> ..... 19 <b>10 Layout</b> ..... 19 10.1 Layout Guidelines ..... 19 10.2 Layout Example ..... 19 <b>11 Device and Documentation Support</b> ..... 21 11.1 Device Support ..... 21 11.2 Community Resources..... 21 11.3 Trademarks ..... 21 11.4 Electrostatic Discharge Caution..... 21 11.5 Glossary ..... 21 <b>12 Mechanical, Packaging, and Orderable Information</b> ..... 21
--	--

## 4 Revision History

NOTE: Page numbers for previous revisions may differ from page numbers in the current version.

Changes from Revision G (February 2013) to Revision H	Page
<ul style="list-style-type: none"> <li>• Added <i>ESD Ratings</i>, <i>Thermal Information</i> table, <i>Feature Description</i> section, <i>Device Functional Modes</i>, <i>Application and Implementation</i> section, <i>Power Supply Recommendations</i> section, <i>Layout</i> section, <i>Device and Documentation Support</i> section, and <i>Mechanical, Packaging, and Orderable Information</i> section. ....</li> </ul>	1

Changes from Revision F (February 2013) to Revision G	Page
<ul style="list-style-type: none"> <li>• Changed layout of National Data Sheet to TI format .....</li> </ul>	20

## 5 Pin Configuration and Functions

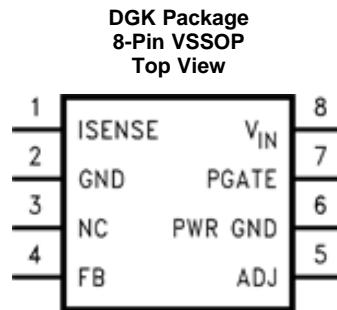

### Pin Functions

NO.	NAME	I/O	DESCRIPTION
1	ISENSE	I	The current sense input pin. This pin should be connected to Drain node of the external PFET.
2	GND	G	Signal ground
3	NC	—	No connection
4	FB	I	The feedback input. Connect the FB to a resistor voltage divider between the output and GND for an adjustable output voltage.
5	ADJ	I	Current limit threshold adjustment. It connects to an internal 5.5- $\mu$ A current source. A resistor is connected between this pin and the input Power Supply. The voltage across this resistor is compared with the V <sub>DS</sub> of the external PFET to determine if an over-current condition has occurred.
6	PWR GND	G	Power ground
7	PGATE	O	Gate Drive output for the external PFET. PGATE swings between V <sub>IN</sub> and V <sub>IN</sub> -5 V.
8	VIN	P/I	Power supply input pin

## 6 Specifications

### 6.1 Absolute Maximum Ratings

over operating free-air temperature range (unless otherwise noted)<sup>(1)</sup>

		MIN	TYP	MAX	UNIT
PGATE voltage		-0.3		36	V
FB voltage		-0.3		5	V
ISENSE voltage		-1.0		36	V
ADJ voltage		-0.3		36	V
Maximum junction temperature			150		°C
Power dissipation (at T <sub>A</sub> = 25°C)		417			mW
Lead temperature	Vapor phase (60 sec.)		215		°C
	Infrared (15 sec.)		220		°C
Storage temperature, T <sub>stg</sub>		-65		160	°C

(1) Stresses beyond those listed under *Absolute Maximum Ratings* may cause permanent damage to the device. These are stress ratings only, which do not imply functional operation of the device at these or any other conditions beyond those indicated under *Recommended Operating Conditions*. Exposure to absolute-maximum-rated conditions for extended periods may affect device reliability.

### 6.2 ESD Ratings

		VALUE	UNIT
V <sub>(ESD)</sub>	Electrostatic discharge Human-body model (HBM), per ANSI/ESDA/JEDEC JS-001 <sup>(1)</sup>	±2000	V

(1) JEDEC document JEP155 states that 500-V HBM allows safe manufacturing with a standard ESD control process.

### 6.3 Recommended Operating Conditions

		MIN	NOM	MAX	UNIT
Supply voltage		4.5		35	V
T <sub>J</sub>	Operating junction temperature	-40		125	°C

### 6.4 Thermal Information

THERMAL METRIC <sup>(1)</sup>		LM3485	UNIT
		DGK (VSSOP)	
		8 PINS	
R <sub>θJA</sub>	Junction-to-ambient thermal resistance	163.3	°C/W
R <sub>θJC(top)</sub>	Junction-to-case (top) thermal resistance	56.7	°C/W
R <sub>θJB</sub>	Junction-to-board thermal resistance	83.2	°C/W
ψ <sub>JT</sub>	Junction-to-top characterization parameter	5.9	°C/W
ψ <sub>JB</sub>	Junction-to-board characterization parameter	81.9	°C/W
R <sub>θJC(bot)</sub>	Junction-to-case (bottom) thermal resistance	N/A	°C/W

(1) For more information about traditional and new thermal metrics, see the *Semiconductor and IC Package Thermal Metrics* application report, [SPRA953](#).

## 6.5 Electrical Characteristics

Specifications are for  $T_J = 25^\circ\text{C}$ . Unless otherwise specified,  $V_{IN} = 12\text{ V}$ ,  $V_{ISNS} = V_{IN} - 1\text{ V}$ , and  $V_{ADJ} = V_{IN} - 1.1\text{ V}$ . Data sheet minimum and maximum specification limits are specified by design, test, or statistical analysis.

PARAMETER		TEST CONDITIONS	MIN <sup>(1)</sup>	TYP <sup>(2)</sup>	MAX <sup>(1)</sup>	UNIT
$I_Q$	Quiescent current at ground pin	FB = 1.5 V (Not Switching)	250			$\mu\text{A}$
		( $T_J = -40^\circ\text{C}$ to $125^\circ\text{C}$ )	400			
$V_{FB}$	Feedback voltage <sup>(3)</sup>		1.226	1.242	1.258	V
		( $T_J = -40^\circ\text{C}$ to $125^\circ\text{C}$ )	1.217		1.267	
$V_{HYST}$	Comparator hysteresis		10		15	mV
		( $T_J = -40^\circ\text{C}$ to $125^\circ\text{C}$ )	14		20	
$V_{CL}$ <sup>(4)</sup>	Current limit comparator trip voltage	$R_{ADJ} = 20\text{ k}\Omega$	110			mV
		$R_{ADJ} = 160\text{ k}\Omega$	880			
$V_{CL\_OFFSET}$	Current limit comparator offset	$V_{FB} = 1.5\text{ V}$	0			mV
		( $T_J = -40^\circ\text{C}$ to $125^\circ\text{C}$ )	-20	20		
$I_{CL\_ADJ}$	Current limit ADJ current source	$V_{FB} = 1.5\text{ V}$	5.5			$\mu\text{A}$
		( $T_J = -40^\circ\text{C}$ to $125^\circ\text{C}$ )	3.0	7.0		
$T_{ONMIN\_CLCL}$	Current limit one shot off time	$V_{ADJ} = 11.5\text{ V}$ $V_{ISNS} = 11.0\text{ V}$ $V_{FB} = 1.0\text{ V}$	9			$\mu\text{s}$
		( $T_J = -40^\circ\text{C}$ to $125^\circ\text{C}$ )	6	14		
$R_{PGATE}$	Driver resistance	Source $I_{SOURCE} = 100\text{ mA}$	5.5			$\Omega$
		Sink $I_{SINK} = 100\text{ mA}$	8.5			
$I_{PGATE}$	Driver output current	Source $V_{IN} = 7\text{ V}$ , $P_{GATE} = 3.5\text{ V}$	0.44			A
		Sink $V_{IN} = 7\text{ V}$ , $P_{GATE} = 3.5\text{ V}$	0.32			
$I_{FB}$	FB pin bias current <sup>(5)</sup>	$V_{FB} = 1.0\text{ V}$	300			nA
		( $T_J = -40^\circ\text{C}$ to $125^\circ\text{C}$ )	750			
$T_{ONMIN\_NOR}$	Minimum on time in normal operation	$V_{ISNS} = V_{ADJ} + 0.1\text{ V}$ $C_{load\ on\ OUT} = 1000\text{ pF}$ <sup>(6)</sup>	100			ns
$T$	Minimum on time in current limit	$V_{ISNS} = V_{ADJ} + 0.1\text{ V}$ $V_{FB} = 1.0\text{ V}$ $C_{load\ on\ OUT} = 1000\text{ pF}$ <sup>(6)</sup>	175			ns
$\%V_{FB}/\Delta V_{IN}$	Feedback voltage line regulation	$4.5 \leq V_{IN} \leq 35\text{ V}$	0.010%			

(1) All limits are at room temperature unless otherwise specified. All room temperature limits are 100% tested. All limits at temperature extremes are specified via correlation using standard Statistical Quality Control (SQC) methods. All limits are used to calculate Average Outgoing Quality Level (AOQL).

(2) Typical numbers are at  $25^\circ\text{C}$  and represent the most likely norm.

(3) The  $V_{FB}$  is the trip voltage at the FB pin when PGATE switches from high to low.

(4)  $V_{CL} = I_{CL\_ADJ} \times R_{ADJ}$

(5) Bias current flows out from the FB pin.

(6) A 1000-pF capacitor is connected between  $V_{IN}$  and PGATE.

## 6.6 Typical Characteristics

Unless otherwise specified,  $T_J = 25^\circ\text{C}$

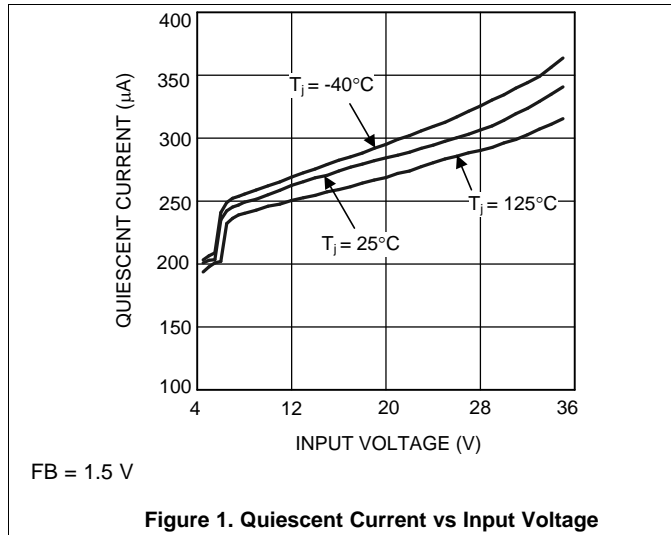

Figure 1. Quiescent Current vs Input Voltage

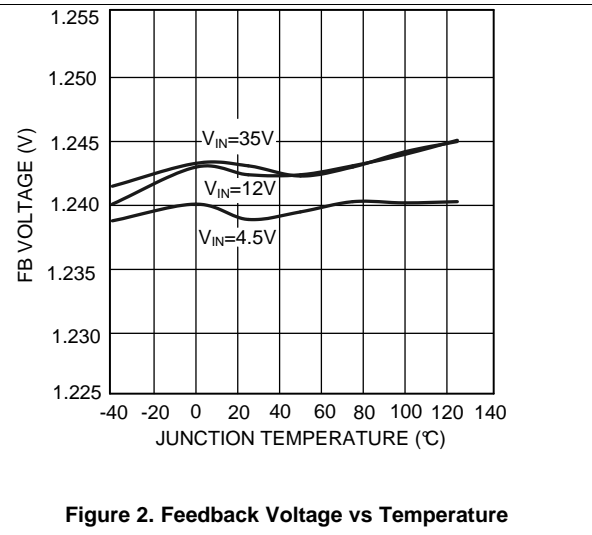

Figure 2. Feedback Voltage vs Temperature

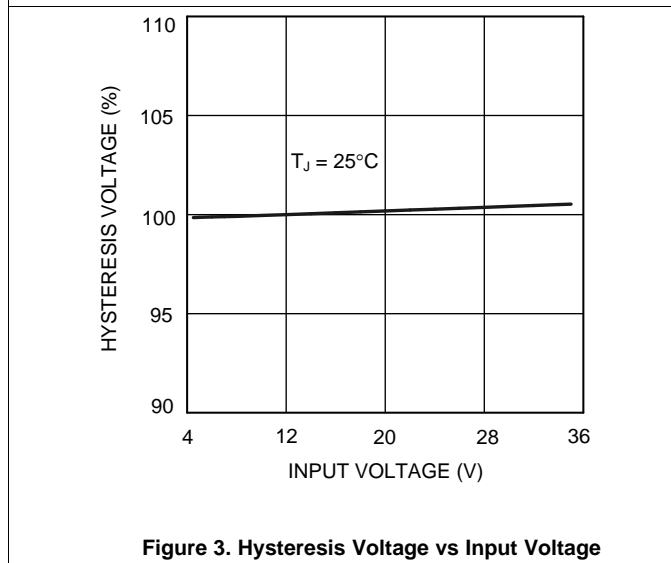

Figure 3. Hysteresis Voltage vs Input Voltage

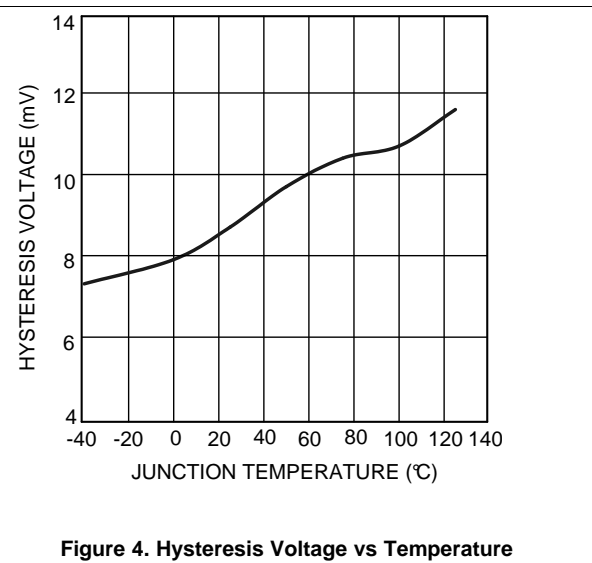

Figure 4. Hysteresis Voltage vs Temperature

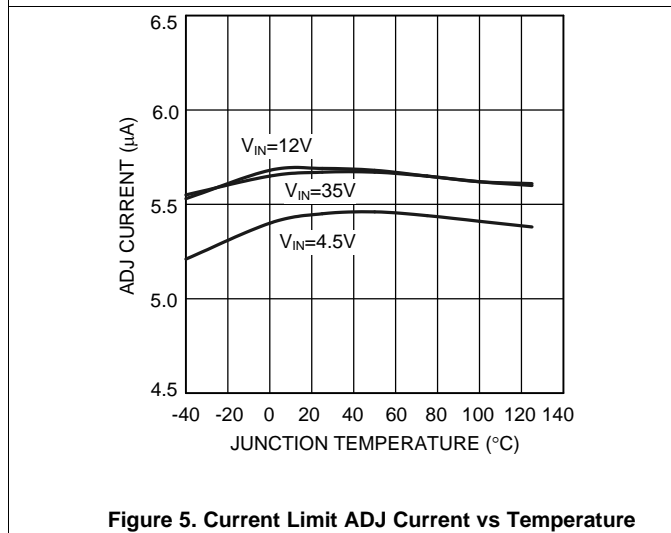

Figure 5. Current Limit ADJ Current vs Temperature

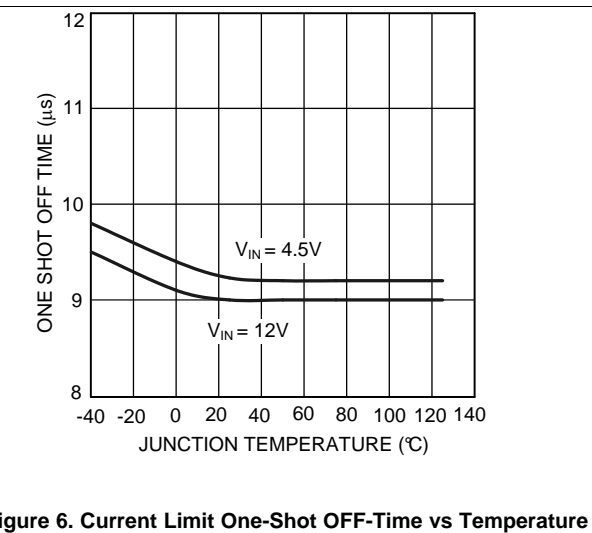

Figure 6. Current Limit One-Shot OFF-Time vs Temperature

Typical Characteristics (continued)

Unless otherwise specified,  $T_J = 25^\circ\text{C}$

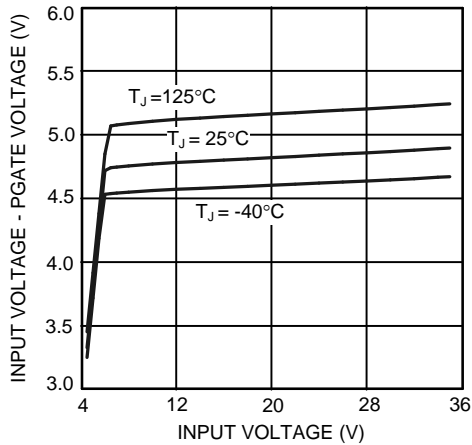
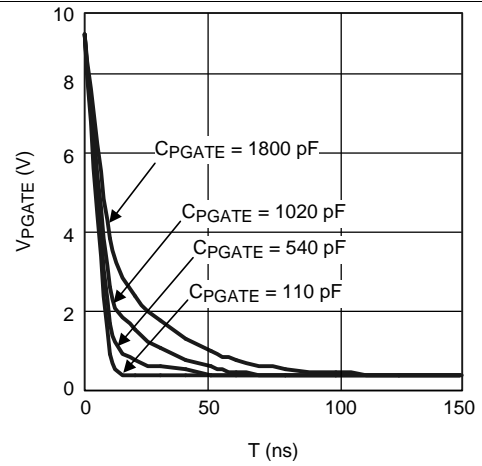

Figure 7. PGATE Voltage vs Input Voltage



$V_{IN} = 9\text{ V}$

Figure 8. Typical  $V_{PGATE}$  vs Time

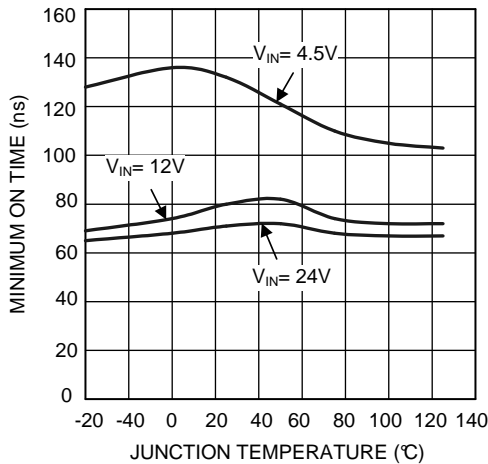
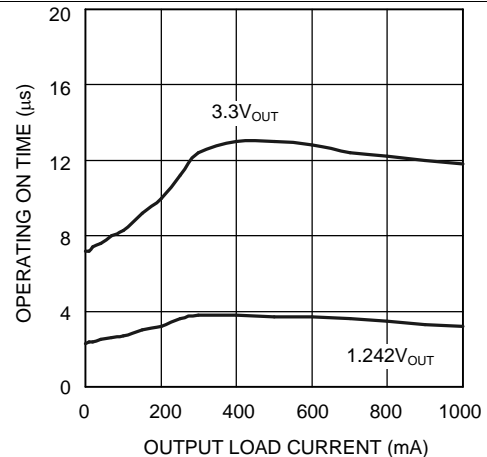
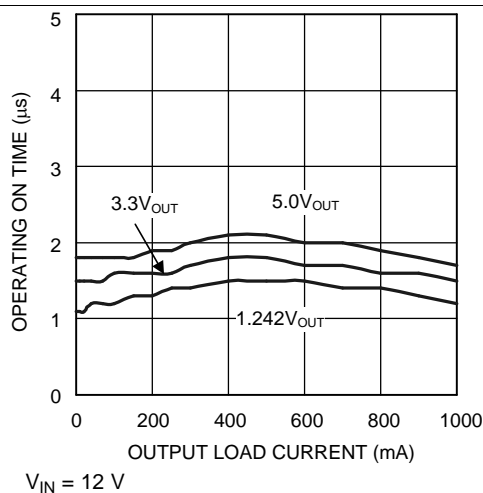

Figure 9. Minimum ON-Time vs Temperature



$V_{IN} = 4.5\text{ V}$

Figure 10. Operating ON-Time vs Output Load Current



$V_{IN} = 12\text{ V}$

Figure 11. Operating ON-Time vs Output Load Current

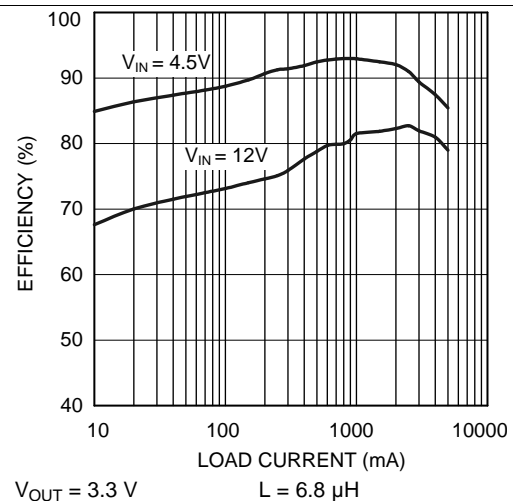

$V_{OUT} = 3.3\text{ V}$

$L = 6.8\ \mu\text{H}$

Figure 12. Efficiency vs Load Current

Typical Characteristics (continued)

Unless otherwise specified,  $T_J = 25^\circ\text{C}$

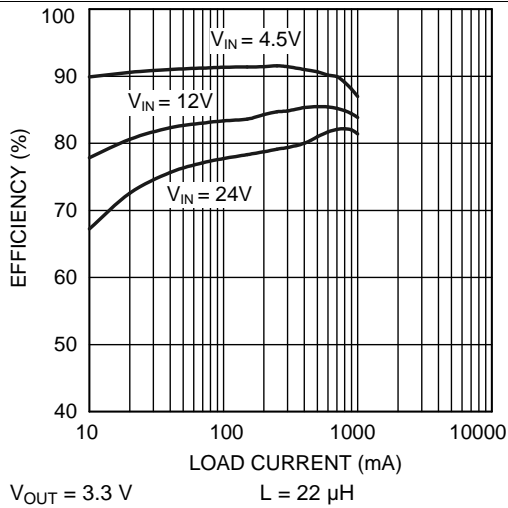

Figure 13. Efficiency vs Load Current

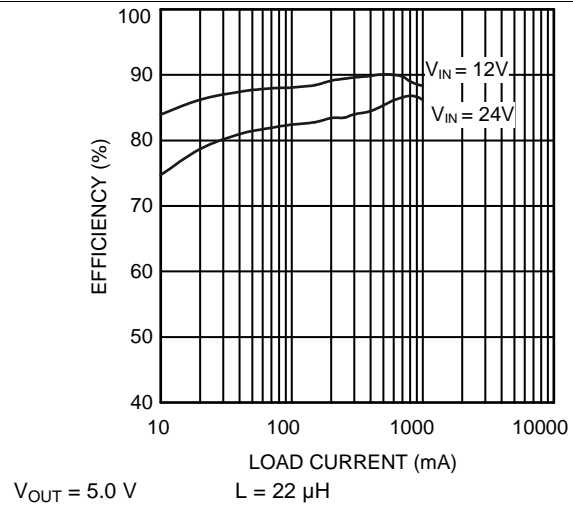

Figure 14. Efficiency vs Load Current

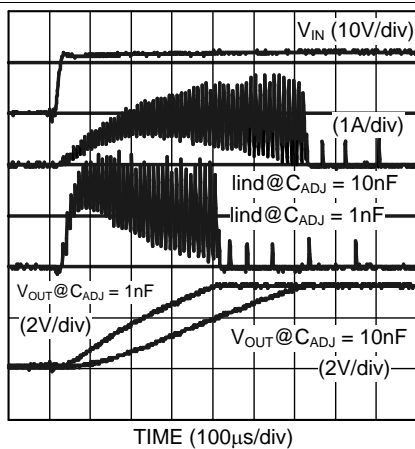

Figure 15. Start Up

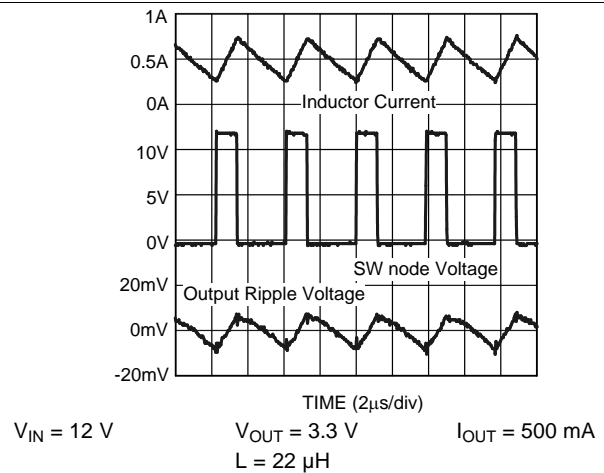

Figure 16. Continuous Mode Operation

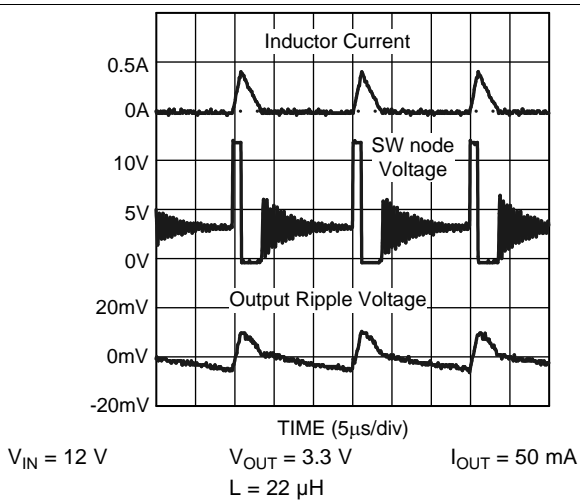

Figure 17. Discontinuous Mode Operation

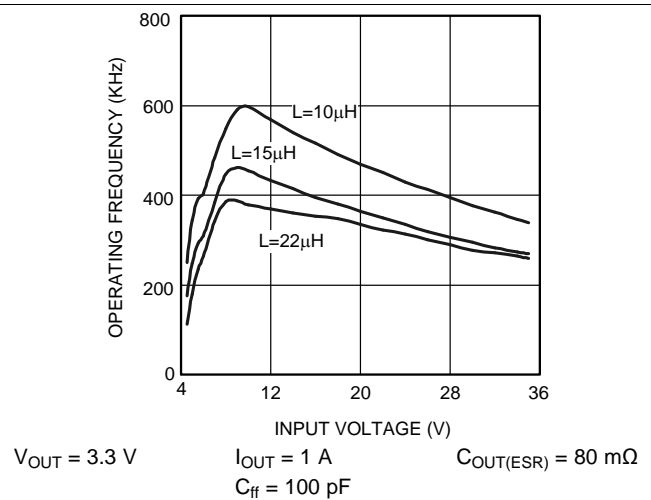
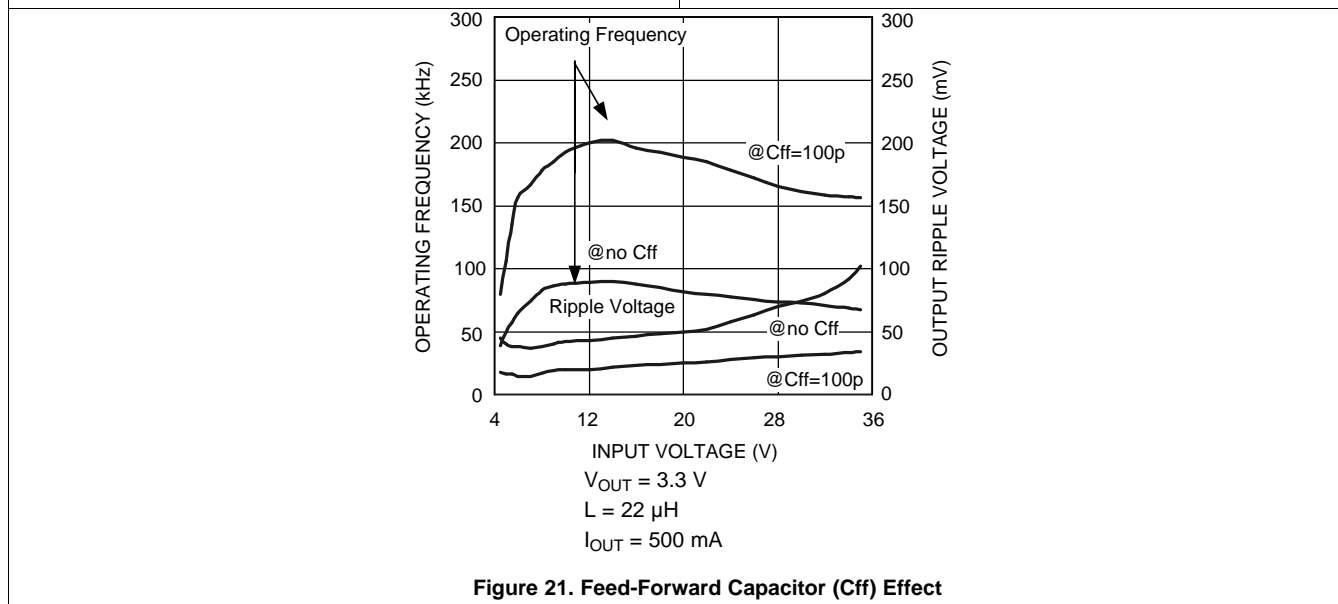
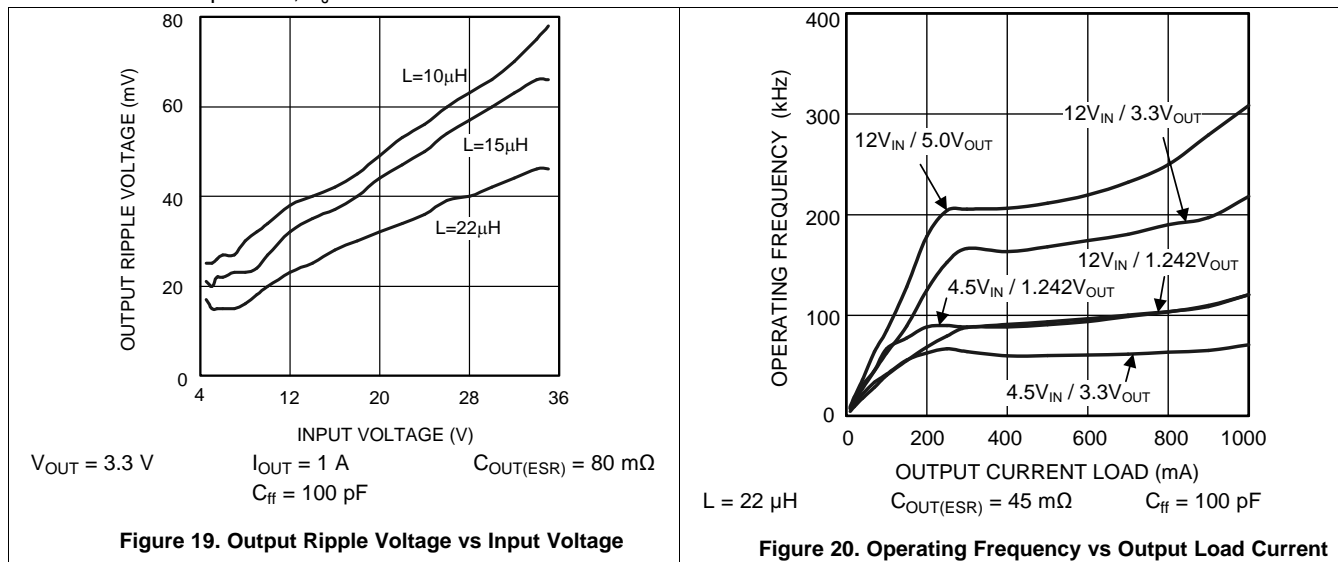

Figure 18. Operating Frequency vs Input Voltage

Typical Characteristics (continued)

Unless otherwise specified,  $T_J = 25^\circ\text{C}$



## 7 Detailed Description

### 7.1 Overview

The LM3485 is buck (step-down) DC-DC controller that uses a hysteretic control scheme. The comparator is designed with approximately 10 mV of hysteresis. In response to the voltage at the FB pin, the gate drive (PGATE pin) turns the external PFET on or off. When the inductor current is too high, the current limit protection circuit engages and turns the PFET off for approximately 9  $\mu$ s.

Hysteretic control does not require an internal oscillator. Switching frequency depends on the external components and operating conditions. Operating frequency reduces at light loads resulting in excellent efficiency compared to other architectures.

Two external resistors can easily program the output voltage. The output can be set in a wide range from 1.242-V (typical) to  $V_{IN}$ .

### 7.2 Functional Block Diagram

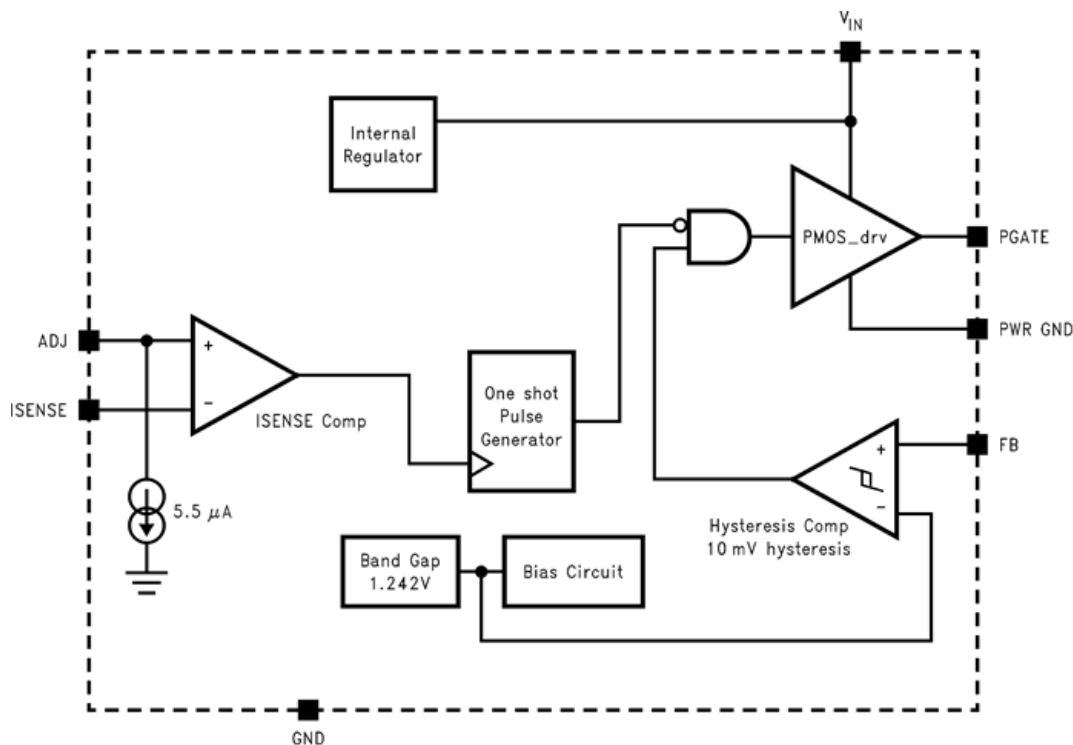

### 7.3 Feature Description

#### 7.3.1 Hysteretic Control Circuit

The LM3485 uses a comparator-based voltage control loop. The feedback is compared to a 1.242-V reference, and a 10-mV hysteresis is designed into the comparator to ensure noise free operation.

When the FB input to the comparator falls below the reference voltage, the output of the comparator moves to a low state. This results in the driver output, PGATE, pulling the gate of the PFET low and turning on the PFET. With the PFET on, the input supply charges  $C_{out}$  and supplies current to the load via the series path through the PFET and the inductor. Current through the Inductor ramps up linearly and the output voltage increases. As the FB voltage reaches the upper threshold, which is the internal reference voltage plus 10 mV, the output of the comparator changes from low to high, and the PGATE responds by turning the PFET off. As the PFET turns off, the inductor voltage reverses, the catch diode turns on, and the current through the inductor ramps down. Then, as the output voltage reaches the internal reference voltage again, the next cycle starts.

## Feature Description (continued)

The LM3485 operates in discontinuous conduction mode at light load current or continuous conduction mode at heavy load current. In discontinuous conduction mode, current through the inductor starts at zero and ramps up to the peak, then ramps down to zero. Next cycle starts when the FB voltage reaches the internal voltage. Until then, the inductor current remains zero. Operating frequency is lower and switching losses reduce. In continuous conduction mode, current always flows through the inductor and never ramps down to zero.

The output voltage ( $V_{OUT}$ ) can be programmed by two external resistors. It can be calculated as [Equation 1](#):

$$V_{OUT} = 1.242 \times (R1 + R2) / R2 \quad (1)$$

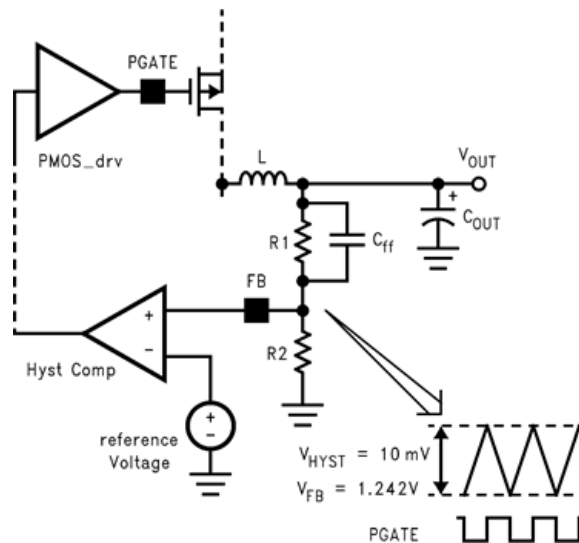

Figure 22. Hysteretic Window

The minimum output voltage ripple ( $V_{OUT\_PP}$ ) can be calculated in the same way.

$$V_{OUT\_PP} = V_{HYST} (R1 + R2) / R2 \quad (2)$$

For example, with  $V_{OUT}$  set to 3.3 V,  $V_{OUT\_PP}$  is 26.6 mV

$$V_{OUT\_PP} = 0.01 \times (33K + 20K) / 20K = 0.0266 \text{ V} \quad (3)$$

Operating frequency (F) is determined by knowing the input voltage, output voltage, inductor,  $V_{HYST}$ , equivalent series resistance (ESR) of output capacitor, and the delay. It can be approximately calculated using [Equation 4](#):

$$F = \frac{V_{OUT}}{V_{IN}} \times \frac{(V_{IN} - V_{OUT}) \times ESR}{(V_{HYST} \times \alpha \times L) + (V_{IN} \times \text{delay} \times ESR)}$$

where

- $(R1 + R2) / R2$
- delay: It includes the LM3485 propagation delay time and the PFET delay time (4)

The propagation delay is 90-ns typically (see [Figure 23](#)).

## Feature Description (continued)

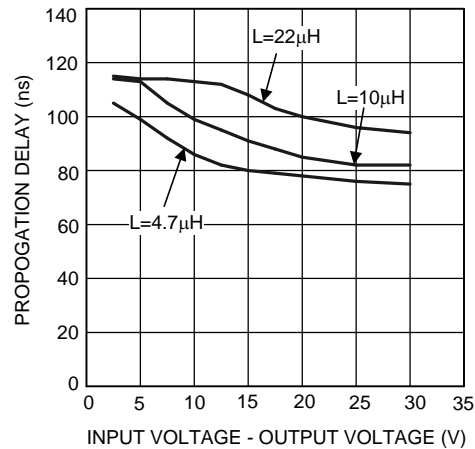

**Figure 23. Propagation Delay**

The operating frequency and output ripple voltage can also be significantly influenced by the speed up capacitor ( $C_{ff}$ ).  $C_{ff}$  is connected in parallel with the high-side feedback resistor,  $R_1$ . The location of this capacitor is similar to where a feed-forward capacitor would be located in a PWM control scheme. However, the effect on hysteretic operation is much different. The output ripple causes a current to be sourced or sunk through this capacitor. This current is essentially a square wave. Because the input to the feedback pin, FB, is a high impedance node, the current flows through  $R_2$ . The end result is a reduction in output ripple and an increase in operating frequency. When adding  $C_{ff}$ , calculate Equation 4 with  $\alpha = 1$ . The value of  $C_{ff}$  depends on the desired operating frequency and the value of  $R_2$ . A good starting point is 470-pF ceramic at 100-kHz decreasing linearly with increased operating frequency. Also, as the output voltage is programmed below 2.5 V, the effect of  $C_{ff}$  will decrease significantly.

### 7.3.2 Current Limit Operation

The LM3485 has a cycle-by-cycle current limit. Current limit is sensed across the  $V_{DS}$  of the PFET or across an additional sense resistor. When current limit is activated, the LM3485 turns off the external PFET for a period of 9  $\mu$ s (typical). The current limit is adjusted by an external resistor,  $R_{ADJ}$ .

The current limit circuit is composed of the ISENSE comparator and the one-shot pulse generator. The positive input of the ISENSE comparator is the ADJ pin. An internal 5.5- $\mu$ A current sink creates a voltage across the external  $R_{ADJ}$  resistor. This voltage is compared to the voltage across the PFET or sense resistor. The ADJ voltage can be calculated with Equation 5.

$$V_{ADJ} = V_{IN} - (R_{ADJ} \times 3.0 \mu A)$$

where

- 3.0  $\mu$ A is the minimum  $I_{CL-ADJ}$  value (5)

The negative input of the ISENSE comparator is the ISENSE pin that should be connected to the drain of the external PFET. The inductor current is determined by sensing the  $V_{DS}$ . It can be calculated with Equation 6.

$$V_{ISENSE} = V_{IN} - (R_{DS(on)} \times I_{IND\_PEAK}) = V_{IN} - V_{DS} \quad (6)$$

Feature Description (continued)

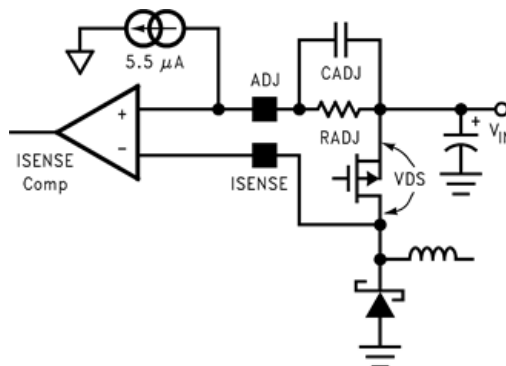

Figure 24. Current Sensing by  $V_{DS}$

The current limit is activated when the voltage at the ADJ pin exceeds the voltage at the  $I_{SENSE}$  pin. The ISENSE comparator triggers the 9- $\mu$ s one shot pulse generator forcing the driver to turn the PFET off. The driver turns the PFET back on after 9  $\mu$ s. If the current has not reduced below the set threshold, the cycle will repeat continuously.

A filter capacitor,  $C_{ADJ}$ , should be placed as shown in Figure 24.  $C_{ADJ}$  filters unwanted noise so that the ISENSE comparator will not be accidentally triggered. A value of 100 pF to 1 nF is recommended in most applications. Higher values can be used to create a soft-start function (see [Start Up](#)).

The current limit comparator has approximately 100 ns of blanking time. This ensures that the PFET is fully on when the current is sensed. However, under extreme conditions such as cold temperature, some PFETs may not fully turn on within the blanking time. In this case, the current limit threshold must be increased. If the current limit function is used, the on time must be greater than 100 ns. Under low duty cycle operation, the maximum operating frequency will be limited by this minimum on time.

During current limit operation, the output voltage will drop significantly as will operating frequency. As the load current is reduced, the output will return to the programmed voltage. However, there is a current limit foldback phenomenon inherent in this current limit architecture. See Figure 25.

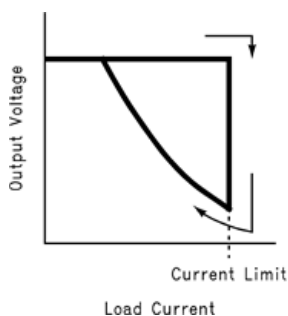

Figure 25. Current Limit Fold Back Phenomenon

At high input voltages (>28 V) increased undershoot at the switch node can cause an increase in the current limit threshold. To avoid this problem, a low  $V_f$  Schottky catch diode must be used (see [Catch Diode Selection \(D1\)](#)). Additionally, a resistor can be placed between the ISENSE pin and the switch node. Any value up to approximately 600  $\Omega$  is recommended.

## 7.4 Device Functional Modes

### 7.4.1 Start Up

The current limit circuit is active during start-up. During start-up the PFET will stay on until either the current limit or the feedback comparator is tripped.

If the current limit comparator is tripped first then the fold back characteristic should be taken into account. Start-up into full load may require a higher current limit set point or the load must be applied after start-up.

One problem with selecting a higher current limit is inrush current during start-up. Increasing the capacitance ( $C_{ADJ}$ ) in parallel with  $R_{ADJ}$  results in soft-start.  $C_{ADJ}$  and  $R_{ADJ}$  create an RC time constant forcing current limit to activate at a lower current. The output voltage will ramp more slowly when using the soft-start functionality. There are example start-up plots for  $C_{ADJ}$  equal to 1 nF and 10 nF in [Typical Characteristics](#). Lower values for  $C_{ADJ}$  will have little to no effect on soft-start.

### 7.4.2 External Sense Resistor

The  $V_{DS}$  of a PFET will tend to vary significantly over temperature. This will result in an equivalent variation in current limit. To improve current limit accuracy an external sense resistor can be connected from  $V_{IN}$  to the source of the PFET, as shown in [Figure 26](#).

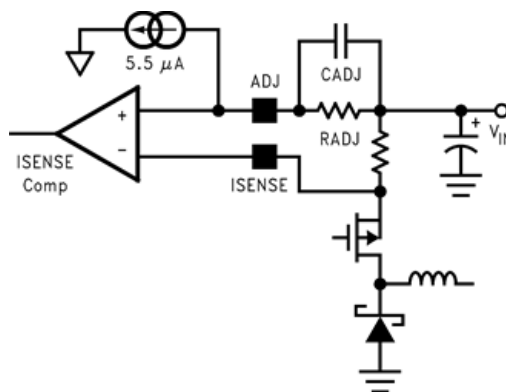

**Figure 26. Current Sensing by External Resistor**

### 7.4.3 PGATE

When switching, the PGATE pin swings from  $V_{IN}$  (off) to some voltage below  $V_{IN}$  (on). How far the PGATE will swing depends on several factors including the capacitance, on time, and input voltage.

As shown in the [Typical Characteristics](#), PGATE voltage swing will increase with decreasing gate capacitance. Although PGATE voltage will typically be around  $V_{IN}-5$  V, with every small gate capacitances, this value can increase to a typical maximum of  $V_{IN}-8.3$  V.

Additionally, PGATE swing voltage will increase as on time increases. During long on times, such as when operating at 100% duty cycle, the PGATE voltage will eventually fall to its maximum voltage of  $V_{IN}-8.3$  V (typical) regardless of the PFET gate capacitance.

The PGATE voltage will not fall below 0.4 V (typical). Therefore, when the input voltage falls below approximately 9 V, the PGATE swing voltage range will be reduced. At an input voltage of 7 V, for instance, PGATE will swing from 7 V to a minimum of 0.4 V.

## 8 Application and Implementation

### NOTE

Information in the following applications sections is not part of the TI component specification, and TI does not warrant its accuracy or completeness. TI's customers are responsible for determining suitability of components for their purposes. Customers should validate and test their design implementation to confirm system functionality.

### 8.1 Application Information

Hysteretic control is a simple control scheme. However the operating frequency and other performance characteristics highly depend on external conditions and components. If either the inductance, output capacitance, ESR,  $V_{IN}$ , or  $C_{ff}$  is changed, there will be a change in the operating frequency and output ripple. The best approach is to determine what operating frequency is desirable in the application and then begin with the selection of the inductor and  $C_{OUT}$  ESR.

### 8.2 Typical Application

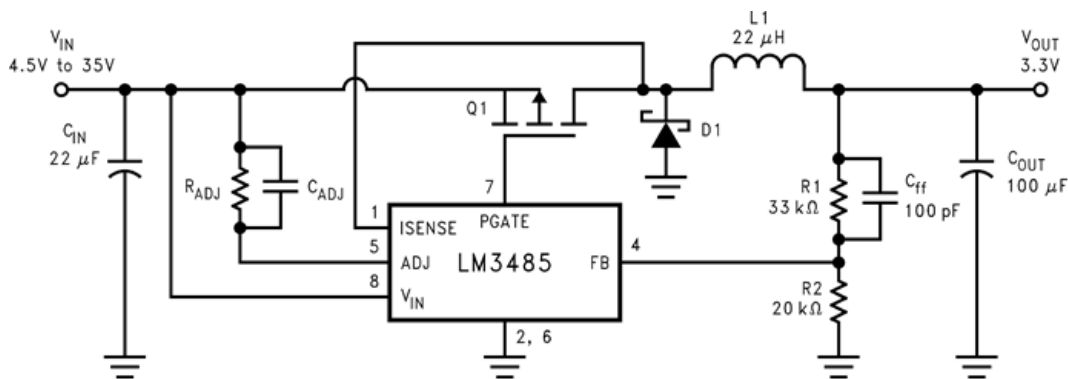

Figure 27. Typical Application Schematic

#### 8.2.1 Design Requirements

For this design example, use the parameters listed in [Table 1](#).

Table 1. Design Parameters

DESIGN PARAMETERS	VALUE
Input Voltage Range	7 V to 28 V
Output Voltage	3.3 V
Output Current Rating	1 A
Output Voltage Ripple	26.6 mV
Operating Frequency ( $V_{IN}$ 12 V, Load Current 1 A)	210 kHz

#### 8.2.2 Detailed Design Procedure

##### 8.2.2.1 Step by Step Design Procedure

To begin the design process, the following items must be considered:

- Output current rating
- Input voltage range
- Output voltage
- Input voltage ripple
- Output voltage ripple

### 8.2.2.2 Inductor Selection (L1)

The important parameters for the inductor are the inductance and the current rating. The LM3485 operates over a wide frequency range and can use a wide range of inductance values. A good rule of thumb is to use the equations used for Simple Switcher<sup>®</sup>. The equation for inductor ripple ( $\Delta i$ ) as a function of output current ( $I_{OUT}$ ) for  $I_{OUT} < 2.0$  Amps is [Equation 7](#):

$$\Delta i \leq I_{out} \times 0.386827 \times I_{out}^{-0.366726} \quad (7)$$

For  $I_{OUT} > 2.0$  Amps, follow [Equation 8](#):

$$\Delta i \leq I_{out} \times 0.3 \quad (8)$$

The inductance can be calculated based upon the desired operating frequency using [Equation 9](#) and [Equation 10](#):

$$L = \frac{V_{IN} - V_{DS} - V_{OUT}}{\Delta i} \cdot \frac{D}{f} \quad (9)$$

$$D = \frac{V_{OUT} + V_D}{V_{IN} - V_{DS} + V_D}$$

where

- D is the duty cycle
  - $V_D$  is the diode forward voltage
  - $V_{DS}$  is the voltage drop across the PFET
- (10)

The inductor should be rated using [Equation 11](#) and [Equation 12](#):

$$I_{pk} = (I_{out} + \Delta i / 2) \times 1.1 \quad (11)$$

$$I_{RMS} = \sqrt{I_{out}^2 + \frac{\Delta i^2}{3}} \quad (12)$$

The inductance value and the resulting ripple is one of the key parameters controlling operating frequency. The second is the ESR.

### 8.2.2.3 Output Voltage Set Point

The output voltage (VOUT) can be programmed by two external resistors. It can be calculated using [Equation 13](#).

$$V_{OUT} = 1.242 \times (R1 + R2) / R2 \quad (13)$$

Refer to [Typical Application](#). A good starting point is to select R2 to be in the range of 10 k $\Omega$  to 20 k $\Omega$ .

### 8.2.2.4 Output Capacitor Selection (C<sub>OUT</sub>)

The ESR of the output capacitor times the inductor ripple current is equal to the output ripple of the regulator. However, the  $V_{HYST}$  sets the first order value of this ripple. As ESR is increased with a given inductance, then operating frequency increases as well. If ESR is reduced then the operating frequency reduces.

The use of ceramic capacitors has become a common practice of many power supply designers. However, ceramic capacitors have a very low ESR resulting in a 90° phase shift of the output voltage ripple. This results in low operating frequency and increased output ripple. To fix this problem a low value resistor should be added in series with the ceramic output capacitor. Although counter intuitive, this combination of a ceramic capacitor and external series resistance provides highly accurate control over the output voltage ripple. The other types of capacitors, such as Sanyo POS CAP and OS-CON, Panasonic SP CAP, Nichicon NA series, are also recommended and may be used without additional series resistance.

For all practical purposes, any type of output capacitor may be used with proper circuit verification.

### 8.2.2.5 Input Capacitor Selection (C<sub>IN</sub>)

A bypass capacitor is required between the input source and ground. It must be located near the source pin of the external PFET. The input capacitor prevents large voltage transients at the input and provides the instantaneous current when the PFET turns on.

The important parameters for the input capacitor are the voltage rating and the RMS current rating. Follow the manufacturer's recommended voltage derating. For high input voltage application, low ESR electrolytic capacitor, the Nichicon *UD* series or the Panasonic *FK* series, is available. The RMS current in the input capacitor can be calculated using [Equation 14](#).

$$I_{RMS\_CIN} = I_{OUT} \times \frac{(V_{OUT} \times (V_{IN} - V_{OUT}))^{1/2}}{V_{IN}} \quad (14)$$

The input capacitor power dissipation can be calculated using [Equation 15](#).

$$P_{D(CIN)} = I_{RMS\_CIN}^2 \times ESR_{CIN} \quad (15)$$

The input capacitor must be able to handle the RMS current and the  $P_D$ . Several input capacitors may be connected in parallel to handle large RMS currents. In some cases it may be much cheaper to use multiple electrolytic capacitors than a single low ESR, high performance capacitor such as OS-CON or Tantalum. The capacitance value should be selected such that the ripple voltage created by the charge and discharge of the capacitance is less than 10% of the total ripple across the capacitor.

### 8.2.2.6 Programming the Current Limit ( $R_{ADJ}$ )

The current limit is determined by connecting a resistor ( $R_{ADJ}$ ) between input voltage and the ADJ pin.

$$R_{ADJ} = I_{IND\_PEAK} \times R_{DSON} / I_{CL\_ADJ}$$

where

- $R_{DSON}$  : Drain-Source ON resistance of the external PFET
- $I_{CL\_ADJ}$  : 3.0  $\mu$ A minimum
- $I_{IND\_PEAK} = I_{LOAD} + I_{RIPPLE} / 2$  (16)

Using the minimum value for  $I_{CL\_ADJ}$  (3.0  $\mu$ A) ensures that the current limit threshold will be set higher than the peak inductor current.

The  $R_{ADJ}$  value must be selected to ensure that the voltage at the ADJ pin does not fall below 3.5 V. With this in mind,

$$R_{ADJ\_MAX} = (V_{IN} - 3.5) / 7 \mu A \quad (17)$$

If a larger  $R_{ADJ}$  value is needed to set the desired current limit, either use a PFET with a lower  $R_{DSON}$ , or use a current sense resistor as shown in [Figure 26](#).

The current limit function can be disabled by connecting the ADJ pin to ground and ISENSE to  $V_{IN}$ .

### 8.2.2.7 Catch Diode Selection (D1)

The important parameters for the catch diode are the peak current, the peak reverse voltage, and the average power dissipation. The average current through the diode can be calculated using [Equation 18](#).

$$I_{D\_AVE} = I_{OUT} \times (1 - D) \quad (18)$$

The off state voltage across the catch diode is approximately equal to the input voltage. The peak reverse voltage rating must be greater than input voltage. In nearly all cases a Schottky diode is recommended. In low output voltage applications a low forward voltage provides improved efficiency. For high temperature applications, diode leakage current may become significant and require a higher reverse voltage rating to achieve acceptable performance.

### 8.2.2.8 P-Channel MOSFET Selection (Q1)

The important parameters for the PFET are the maximum Drain-Source voltage ( $V_{DS}$ ), the on resistance ( $R_{DSON}$ ), Current rating, and the input capacitance.

The voltage across the PFET when it is turned off is equal to the sum of the input voltage and the diode forward voltage. The  $V_{DS}$  must be selected to provide some margin beyond the input voltage.

PFET drain current,  $I_d$ , must be rated higher than the peak inductor current,  $I_{IND\_PEAK}$ .

Depending on operating conditions, the PGATE voltage may fall as low as  $V_{IN} - 8.3$  V. Therefore, a PFET must be selected with a  $V_{GS}$  greater than the maximum PGATE swing voltage.

As input voltage decreases below 9 V, PGATE swing voltage may also decrease. At 5.0-V input the PGATE will swing from  $V_{IN}$  to  $V_{IN} - 4.6$  V. To ensure that the PFET turns on quickly and completely, a low threshold PFET should be used when the input voltage is less than 7 V.

However, PFET switching losses will increase as the  $V_{GS}$  threshold decreases. Therefore, whenever possible, a high threshold PFET should be selected. Total power loss in the FET can be approximated using Equation 19:

$$P_{Dswitch} = R_{DS(on)} \times I_{OUT}^2 \times D + F \times I_{OUT} \times V_{IN} \times (t_{on} + t_{off}) / 2$$

where

- $t_{on}$  = FET turnon time
- $t_{off}$  = FET turnoff time

(19)

A value from 10 ns to 20 ns is typical for  $t_{on}$  and  $t_{off}$ .

A PFET should be selected with a turn on rise time of less than 100 ns. Slower rise times will degrade efficiency, can cause false current limiting, and in extreme cases may cause abnormal spiking at the PGATE pin.

The  $R_{DS(on)}$  is used in determining the current limit resistor value,  $R_{ADJ}$ .

### NOTE

The  $R_{DS(on)}$  has a positive temperature coefficient. At 100°C, the  $R_{DS(on)}$  may be as much as 150% higher than the 25°C value. This increase in  $R_{DS(on)}$  must be considered it when determining  $R_{ADJ}$  in wide temperature range applications. If the current limit is set based upon 25°C ratings, then false current limiting can occur at high temperature.

Keeping the gate capacitance below 2000 pF is recommended to keep switching losses and transition times low. This will also help keep the PFET drive current low, which will improve efficiency and lower the power dissipation within the controller.

As gate capacitance increases, operating frequency should be reduced and as gate capacitance decreases operating frequency can be increased.

### 8.2.3 Application Curves

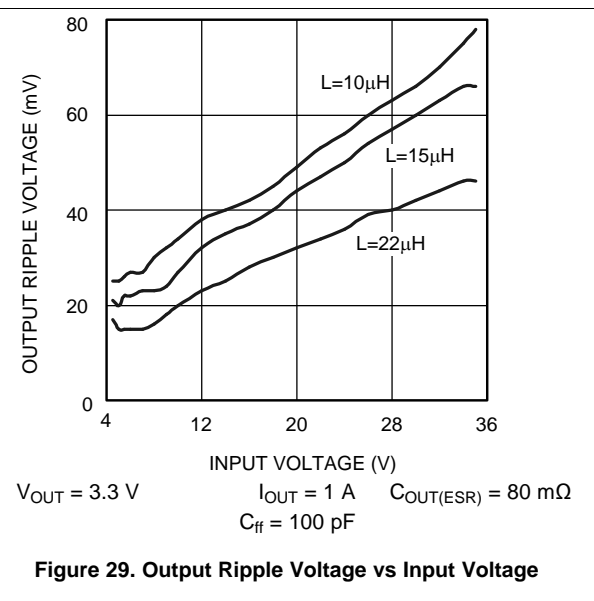
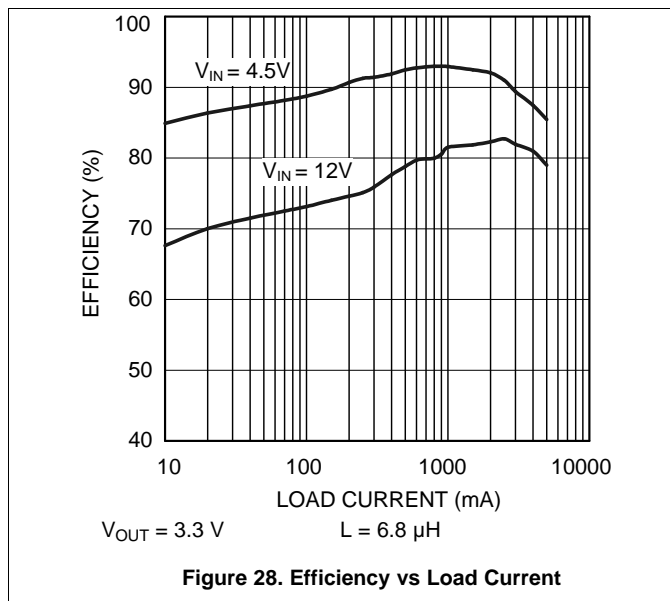

## 9 Power Supply Recommendations

The devices are designed to generate from an input voltage supply range between 4.5 V and 35 V. The input should be well regulated. If the input supply is located more than a few inches from the LM3485 EVM, an additional bulk capacitor may be required. A tantalum capacitor with a value of 47  $\mu$ s as a typical choice.

## 10 Layout

### 10.1 Layout Guidelines

The PC board layout is very important in all switching regulator designs. Poor layout can cause switching noise into the feedback signal and general EMI problems. For minimal inductance, the wires indicated by heavy lines should be as wide and short as possible. Keep the ground pin of the input capacitor as close as possible to the anode of the diode. This path carries a large AC current. The switching node, the node with the diode cathode, inductor, and FET drain, should be kept short. This node is one of the main sources for radiated EMI because it is an AC voltage at the switching frequency. It is always good practice to use a ground plane in the design, particularly at high currents.

The two ground pins, PWR GND and GND, should be connected by as short a trace as possible; they can be connected underneath the device. These pins are resistively connected internally by approximately 50  $\Omega$ . The ground pins should be tied to the ground plane, or to a large ground trace in close proximity to both the FB divider and C<sub>OUT</sub> grounds.

The gate pin of the external PFET should be located close to the PGATE pin. However, if a very small FET is used, a resistor may be required between PGATE and the gate of the FET to reduce high frequency ringing. Because this resistor will slow the rise time of the PFET, the current limit blanking time should be taken into consideration (see [Current Limit Operation](#)).

The feedback voltage signal line can be sensitive to noise. Avoid inductive coupling to the inductor or the switching node, by keeping the FB trace away from these areas.

### 10.2 Layout Example

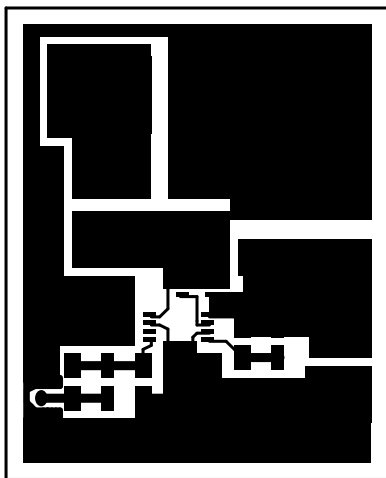

**Figure 30. Top Layer,  
Typical PCB Layout (3.3-V Output)**

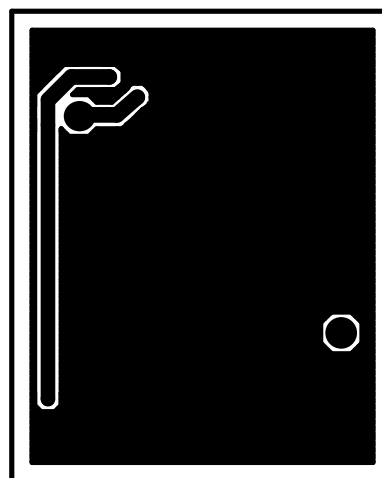

**Figure 31. Bottom Layer,  
Typical PCB Layout (3.3-V Output)**

Layout Example (continued)

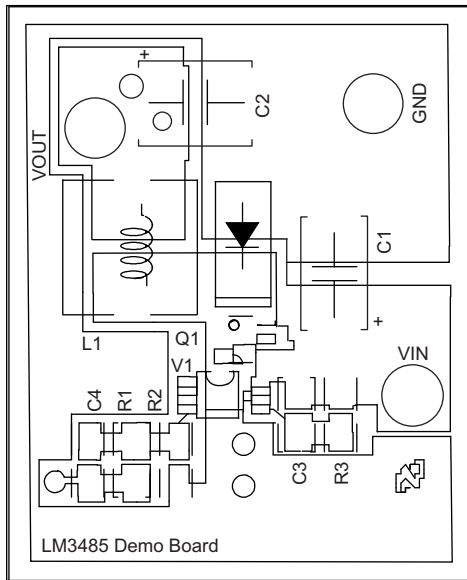

Figure 32. Silk Screen, Typical PCB Layout (3.3-V Output)

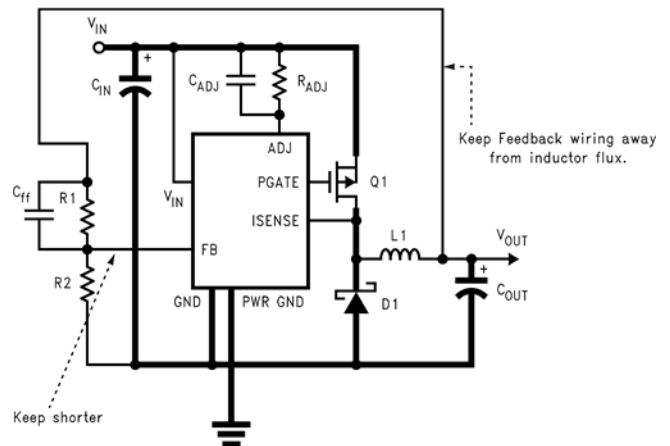

Figure 33. Typical PCB Layout Schematic (3.3-V Output)

Table 2. Typical Application BOM

DESIGNATOR	DESCRIPTION	PART NUMBER	DISTRIBUTOR	
C1	C <sub>OUT</sub>	22-μF to 35-V	EEJL1VD226R	Panasonic
C2	C <sub>IN</sub>	100-μF to 6.3-V	6TPC100M	
C3	C <sub>ADJ</sub>	1-nF ceramic chip capacitor		
C4	C <sub>FF</sub>	100-pF ceramic chip capacitor		
D1		1 A to 40 V	MBRS140T3	On Semiconductor
L1		22 μH	QH66SN220M01L	Murata
Q1			FDC5614P	Fairchild
R1		33k-Ω chip resistor		
R2		20-kΩ chip resistor		
R3	R <sub>ADJ</sub>	240-kΩ chip resistor		

## 11 Device and Documentation Support

### 11.1 Device Support

#### 11.1.1 Third-Party Products Disclaimer

TI'S PUBLICATION OF INFORMATION REGARDING THIRD-PARTY PRODUCTS OR SERVICES DOES NOT CONSTITUTE AN ENDORSEMENT REGARDING THE SUITABILITY OF SUCH PRODUCTS OR SERVICES OR A WARRANTY, REPRESENTATION OR ENDORSEMENT OF SUCH PRODUCTS OR SERVICES, EITHER ALONE OR IN COMBINATION WITH ANY TI PRODUCT OR SERVICE.

### 11.2 Community Resources

The following links connect to TI community resources. Linked contents are provided "AS IS" by the respective contributors. They do not constitute TI specifications and do not necessarily reflect TI's views; see TI's [Terms of Use](#).

**TI E2E™ Online Community** *TI's Engineer-to-Engineer (E2E) Community*. Created to foster collaboration among engineers. At [e2e.ti.com](http://e2e.ti.com), you can ask questions, share knowledge, explore ideas and help solve problems with fellow engineers.

**Design Support** *TI's Design Support* Quickly find helpful E2E forums along with design support tools and contact information for technical support.

### 11.3 Trademarks

E2E is a trademark of Texas Instruments.  
Simple Switcher is a registered trademark of Texas Instruments.  
All other trademarks are the property of their respective owners.

### 11.4 Electrostatic Discharge Caution



These devices have limited built-in ESD protection. The leads should be shorted together or the device placed in conductive foam during storage or handling to prevent electrostatic damage to the MOS gates.

### 11.5 Glossary

[SLYZ022](#) — *TI Glossary*.

This glossary lists and explains terms, acronyms, and definitions.

## 12 Mechanical, Packaging, and Orderable Information

The following pages include mechanical, packaging, and orderable information. This information is the most current data available for the designated devices. This data is subject to change without notice and revision of this document. For browser-based versions of this data sheet, refer to the left-hand navigation.

**PACKAGING INFORMATION**

Orderable Device	Status (1)	Package Type	Package Drawing	Pins	Package Qty	Eco Plan (2)	Lead finish/ Ball material (6)	MSL Peak Temp (3)	Op Temp (°C)	Device Marking (4/5)	Samples
LM3485MM/NOPB	ACTIVE	VSSOP	DGK	8	1000	RoHS & Green	NIPDAUAG   SN	Level-1-260C-UNLIM	-40 to 125	S29B	<a href="#">Samples</a>
LM3485MMX/NOPB	ACTIVE	VSSOP	DGK	8	3500	RoHS & Green	NIPDAUAG   SN	Level-1-260C-UNLIM	-40 to 125	S29B	<a href="#">Samples</a>
LM3485Q1MM/NOPB	ACTIVE	VSSOP	DGK	8	1000	RoHS & Green	SN	Level-1-260C-UNLIM	-40 to 125	SVJB	<a href="#">Samples</a>

(1) The marketing status values are defined as follows:

**ACTIVE:** Product device recommended for new designs.

**LIFEBUY:** TI has announced that the device will be discontinued, and a lifetime-buy period is in effect.

**NRND:** Not recommended for new designs. Device is in production to support existing customers, but TI does not recommend using this part in a new design.

**PREVIEW:** Device has been announced but is not in production. Samples may or may not be available.

**OBSOLETE:** TI has discontinued the production of the device.

(2) **RoHS:** TI defines "RoHS" to mean semiconductor products that are compliant with the current EU RoHS requirements for all 10 RoHS substances, including the requirement that RoHS substance do not exceed 0.1% by weight in homogeneous materials. Where designed to be soldered at high temperatures, "RoHS" products are suitable for use in specified lead-free processes. TI may reference these types of products as "Pb-Free".

**RoHS Exempt:** TI defines "RoHS Exempt" to mean products that contain lead but are compliant with EU RoHS pursuant to a specific EU RoHS exemption.

**Green:** TI defines "Green" to mean the content of Chlorine (Cl) and Bromine (Br) based flame retardants meet JS709B low halogen requirements of <=1000ppm threshold. Antimony trioxide based flame retardants must also meet the <=1000ppm threshold requirement.

(3) MSL, Peak Temp. - The Moisture Sensitivity Level rating according to the JEDEC industry standard classifications, and peak solder temperature.

(4) There may be additional marking, which relates to the logo, the lot trace code information, or the environmental category on the device.

(5) Multiple Device Markings will be inside parentheses. Only one Device Marking contained in parentheses and separated by a "~" will appear on a device. If a line is indented then it is a continuation of the previous line and the two combined represent the entire Device Marking for that device.

(6) Lead finish/Ball material - Orderable Devices may have multiple material finish options. Finish options are separated by a vertical ruled line. Lead finish/Ball material values may wrap to two lines if the finish value exceeds the maximum column width.

**Important Information and Disclaimer:**The information provided on this page represents TI's knowledge and belief as of the date that it is provided. TI bases its knowledge and belief on information provided by third parties, and makes no representation or warranty as to the accuracy of such information. Efforts are underway to better integrate information from third parties. TI has taken and continues to take reasonable steps to provide representative and accurate information but may not have conducted destructive testing or chemical analysis on incoming materials and chemicals. TI and TI suppliers consider certain information to be proprietary, and thus CAS numbers and other limited information may not be available for release.

In no event shall TI's liability arising out of such information exceed the total purchase price of the TI part(s) at issue in this document sold by TI to Customer on an annual basis.

**OTHER QUALIFIED VERSIONS OF LM3485, LM3485-Q1 :**

- Catalog: [LM3485](#)
- Automotive: [LM3485-Q1](#)

NOTE: Qualified Version Definitions:

- Catalog - TI's standard catalog product
- Automotive - Q100 devices qualified for high-reliability automotive applications targeting zero defects

**TAPE AND REEL INFORMATION**

**QUADRANT ASSIGNMENTS FOR PIN 1 ORIENTATION IN TAPE**

\*All dimensions are nominal

Device	Package Type	Package Drawing	Pins	SPQ	Reel Diameter (mm)	Reel Width W1 (mm)	A0 (mm)	B0 (mm)	K0 (mm)	P1 (mm)	W (mm)	Pin1 Quadrant
LM3485MM/NOPB	VSSOP	DGK	8	1000	178.0	12.4	5.3	3.4	1.4	8.0	12.0	Q1
LM3485MMX/NOPB	VSSOP	DGK	8	3500	330.0	12.4	5.3	3.4	1.4	8.0	12.0	Q1
LM3485Q1MM/NOPB	VSSOP	DGK	8	1000	178.0	12.4	5.3	3.4	1.4	8.0	12.0	Q1

**TAPE AND REEL BOX DIMENSIONS**

\*All dimensions are nominal

Device	Package Type	Package Drawing	Pins	SPQ	Length (mm)	Width (mm)	Height (mm)
LM3485MM/NOPB	VSSOP	DGK	8	1000	208.0	191.0	35.0
LM3485MMX/NOPB	VSSOP	DGK	8	3500	367.0	367.0	35.0
LM3485Q1MM/NOPB	VSSOP	DGK	8	1000	208.0	191.0	35.0

# DGK0008A

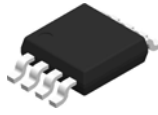

# PACKAGE OUTLINE

## VSSOP - 1.1 mm max height

SMALL OUTLINE PACKAGE

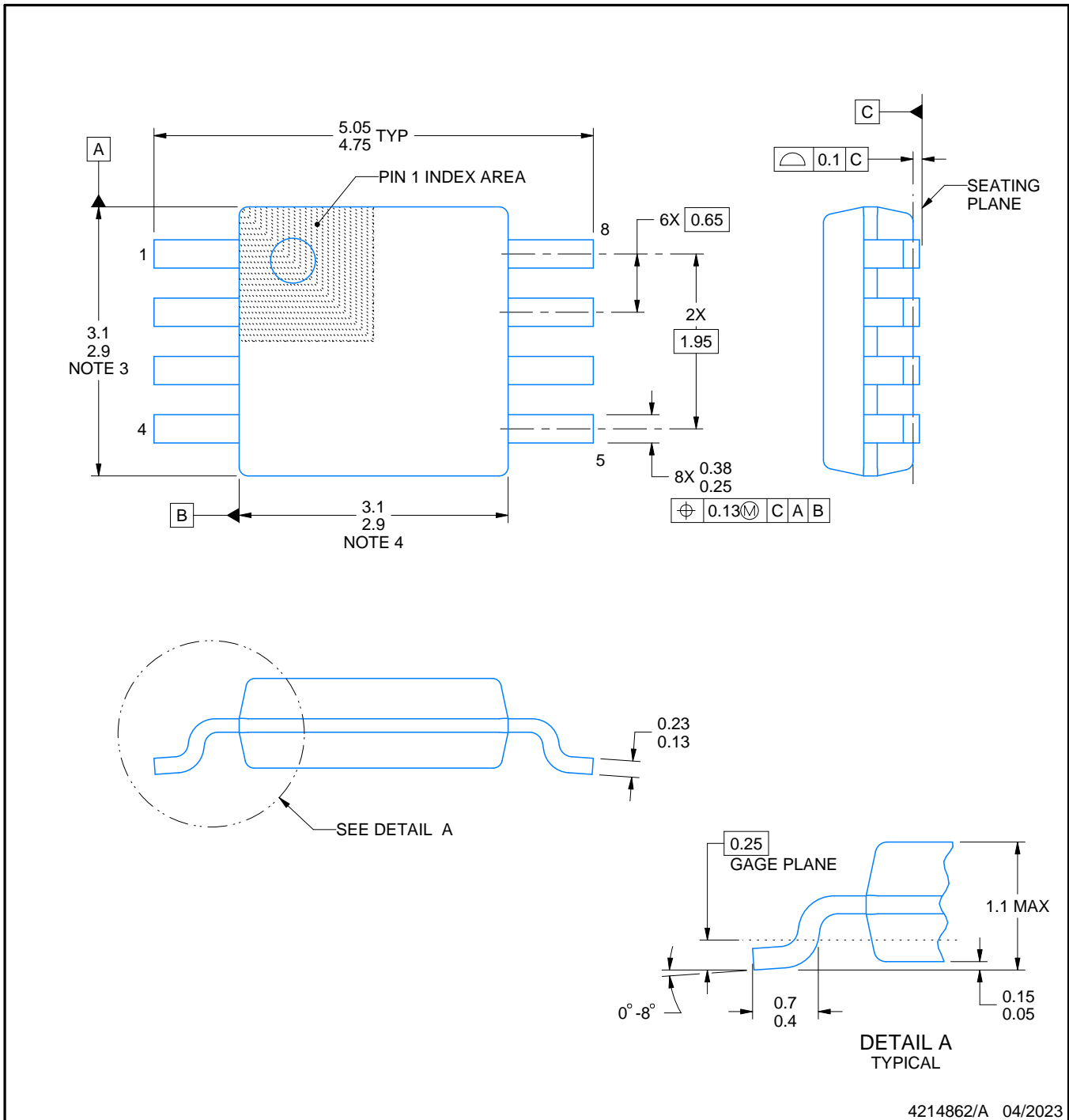

4214862/A 04/2023

### NOTES:

PowerPAD is a trademark of Texas Instruments.

1. All linear dimensions are in millimeters. Any dimensions in parenthesis are for reference only. Dimensioning and tolerancing per ASME Y14.5M.
2. This drawing is subject to change without notice.
3. This dimension does not include mold flash, protrusions, or gate burrs. Mold flash, protrusions, or gate burrs shall not exceed 0.15 mm per side.
4. This dimension does not include interlead flash. Interlead flash shall not exceed 0.25 mm per side.
5. Reference JEDEC registration MO-187.

# EXAMPLE BOARD LAYOUT

DGK0008A

™ VSSOP - 1.1 mm max height

SMALL OUTLINE PACKAGE



LAND PATTERN EXAMPLE  
EXPOSED METAL SHOWN  
SCALE: 15X

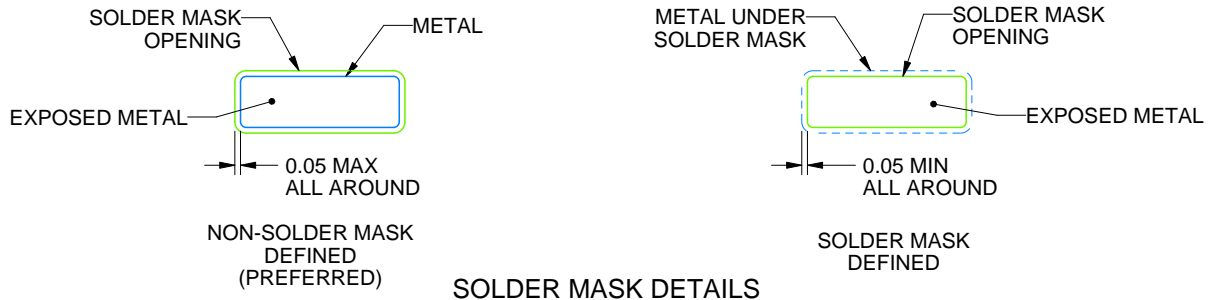

4214862/A 04/2023

NOTES: (continued)

6. Publication IPC-7351 may have alternate designs.
7. Solder mask tolerances between and around signal pads can vary based on board fabrication site.
8. Vias are optional depending on application, refer to device data sheet. If any vias are implemented, refer to their locations shown on this view. It is recommended that vias under paste be filled, plugged or tented.
9. Size of metal pad may vary due to creepage requirement.

# EXAMPLE STENCIL DESIGN

DGK0008A

<sup>TM</sup> VSSOP - 1.1 mm max height

SMALL OUTLINE PACKAGE



SOLDER PASTE EXAMPLE  
SCALE: 15X

4214862/A 04/2023

NOTES: (continued)

11. Laser cutting apertures with trapezoidal walls and rounded corners may offer better paste release. IPC-7525 may have alternate design recommendations.
12. Board assembly site may have different recommendations for stencil design.

## IMPORTANT NOTICE AND DISCLAIMER

TI PROVIDES TECHNICAL AND RELIABILITY DATA (INCLUDING DATA SHEETS), DESIGN RESOURCES (INCLUDING REFERENCE DESIGNS), APPLICATION OR OTHER DESIGN ADVICE, WEB TOOLS, SAFETY INFORMATION, AND OTHER RESOURCES "AS IS" AND WITH ALL FAULTS, AND DISCLAIMS ALL WARRANTIES, EXPRESS AND IMPLIED, INCLUDING WITHOUT LIMITATION ANY IMPLIED WARRANTIES OF MERCHANTABILITY, FITNESS FOR A PARTICULAR PURPOSE OR NON-INFRINGEMENT OF THIRD PARTY INTELLECTUAL PROPERTY RIGHTS.

These resources are intended for skilled developers designing with TI products. You are solely responsible for (1) selecting the appropriate TI products for your application, (2) designing, validating and testing your application, and (3) ensuring your application meets applicable standards, and any other safety, security, regulatory or other requirements.

These resources are subject to change without notice. TI grants you permission to use these resources only for development of an application that uses the TI products described in the resource. Other reproduction and display of these resources is prohibited. No license is granted to any other TI intellectual property right or to any third party intellectual property right. TI disclaims responsibility for, and you will fully indemnify TI and its representatives against, any claims, damages, costs, losses, and liabilities arising out of your use of these resources.

TI's products are provided subject to [TI's Terms of Sale](#) or other applicable terms available either on [ti.com](https://www.ti.com) or provided in conjunction with such TI products. TI's provision of these resources does not expand or otherwise alter TI's applicable warranties or warranty disclaimers for TI products.

TI objects to and rejects any additional or different terms you may have proposed.

Mailing Address: Texas Instruments, Post Office Box 655303, Dallas, Texas 75265  
Copyright © 2024, Texas Instruments Incorporated

## Looking for pricing, stock, or lifecycle information?

Click below to explore more details on WIN SOURCE:

 [View LM3485MMX/NOPB on WIN SOURCE](#)

 [Texas Instruments](#) Information

## Optimize Your Supply Chain with WIN SOURCE Solutions

-  Global Sourcing Solution
-  Obsolete Management
-  Cost Control Management
-  Shortage Management
-  Alternative Solution
-  Excess Inventory Management