



**THE DATASHEET OF
LM34910SD/NOPB**



LM34910 High Voltage (40V, 1.25A) Step Down Switching Regulator

Check for Samples: [LM34910](#)

FEATURES

- Integrated 40V, N-Channel Buck Switch
- Integrated Start-Up Regulator
- Input Voltage Range: 8V to 36V
- No Loop Compensation Required
- Ultra-Fast Transient Response
- Operating Frequency Remains Constant with Load Current and Input Voltage
- Maximum Duty Cycle Limited During Start-Up
- Adjustable Output Voltage
- Valley Current Limit At 1.25A
- Precision Internal Reference
- Low Bias Current
- Highly Efficient Operation
- Thermal Shutdown

TYPICAL APPLICATIONS

- High Efficiency Point-Of-Load (POL) Regulator
- Non-Isolated Telecommunication Buck Regulator
- Secondary High Voltage Post Regulator

Connection Diagram

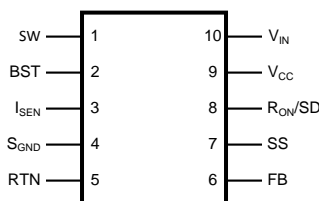

**Figure 1. 10-Lead WSON
See DPR0010A Package**

DESCRIPTION

The LM34910 Step Down Switching Regulator features all of the functions needed to implement a low cost, efficient, buck bias regulator capable of supplying 1.25A to the load. This buck regulator contains a 40V N-Channel Buck Switch, and is available in the thermally enhanced WSON-10 package. The hysteretic regulation scheme requires no loop compensation, results in fast load transient response, and simplifies circuit implementation. The operating frequency remains constant with line and load variations due to the inverse relationship between the input voltage and the on-time. The current limit detection is set at 1.25A. Additional features include: VCC under-voltage lockout, thermal shutdown, gate drive under-voltage lockout, and maximum duty cycle limiter.

Package

- WSON-10 (4 mm x 4 mm)
- Exposed Thermal Pad For Improved Heat Dissipation



Please be aware that an important notice concerning availability, standard warranty, and use in critical applications of Texas Instruments semiconductor products and disclaimers thereto appears at the end of this data sheet.

All trademarks are the property of their respective owners.

Typical Application Circuit and Block Diagram

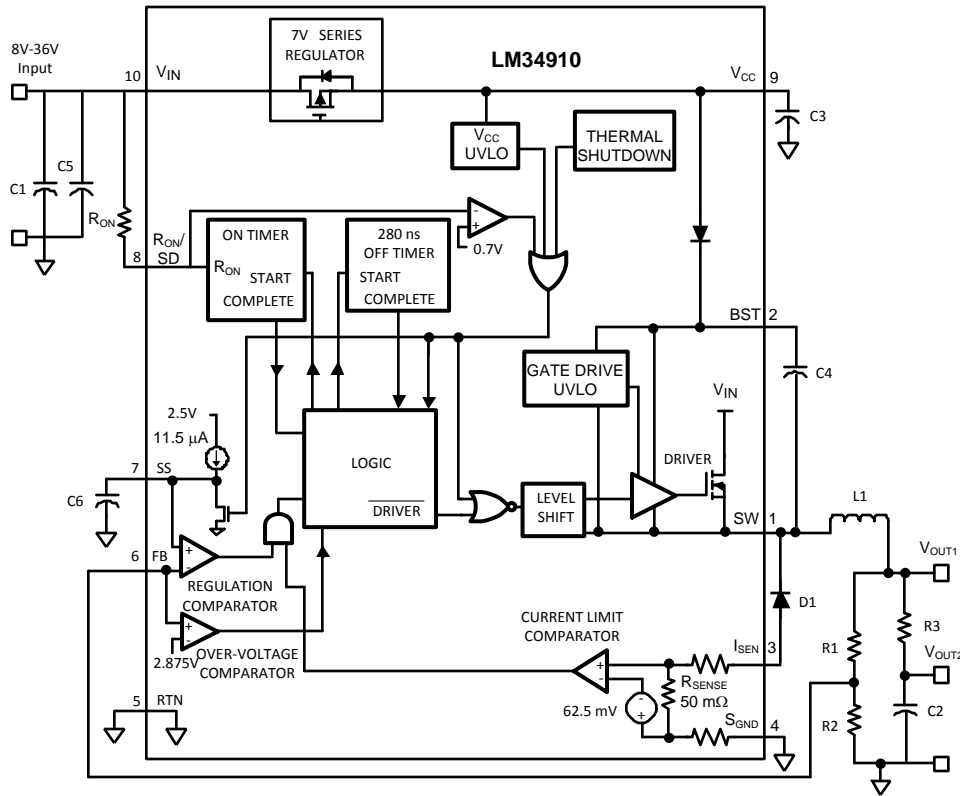

PIN DESCRIPTIONS

PIN	NAME	DESCRIPTION	APPLICATION INFORMATION
1	SW	Switching Node	Internally connected to the buck switch source. Connect to the external inductor, diode, and boost capacitor.
2	BST	Boost pin for boot-strap capacitor	Connect a 0.022 μF capacitor from SW to this pin. An internal diode charges the capacitor during the off-time.
3	I _{SEN}	Current sense input	Internally the current sense resistor connects from this pin to S _{GND} . Re-circulating current flows out of this pin to the free-wheeling diode. Current limit is set at 1.25A.
4	S _{GND}	Sense Ground	Re-circulating current flows into this pin to the current sense resistor.
5	RTN	Circuit Ground	Ground for all internal circuitry other than the current limit detection.
6	FB	Feedback	Internally connected to the regulation and over-voltage comparators. The regulation level is 2.5V.
7	SS	Softstart	An internal 11.5 μA current source charges an external capacitor to 2.5V to provide the softstart function.
8	R _{ON} /SD	On-time Control and Shutdown	An external resistor from V _{IN} to this pin sets the buck switch on-time. Grounding this pin shuts down the regulator.
9	V _{CC}	Output from the start-up regulator	Nominally regulated to 7.0V. An external voltage (8V-14V) can be connected to this pin to reduce internal dissipation. An internal diode connects V _{CC} to V _{IN} .
10	V _{IN}	Input supply voltage	Nominal input range is 8.0V to 36V.



These devices have limited built-in ESD protection. The leads should be shorted together or the device placed in conductive foam during storage or handling to prevent electrostatic damage to the MOS gates.

Absolute Maximum Ratings⁽¹⁾⁽²⁾

V_{IN} to GND		40V
BST to GND		50V
SW to GND (Steady State)		-1.5V
ESD Rating ⁽³⁾	Human Body Model	2kV
BST to V_{CC}		40V
V_{IN} to SW		40V
BST to SW		14V
V_{CC} to GND		14V
S_{GND} to RTN		-0.3V to +0.3V
Current out of I_{SEN}		See Text
SS to RTN		-0.3V to 4V
All Other Inputs to GND		-0.3 to 7V
Storage Temperature Range		-55°C to +150°C
Junction Temperature		150°C

- (1) Absolute Maximum Ratings are limits beyond which damage to the device may occur. Operating Ratings are conditions under which operation of the device is intended to be functional. For guaranteed specifications and test conditions, see the [Electrical Characteristics](#).
- (2) For detailed information on soldering plastic WSON packages, refer to the Packaging Data Book available from National Semiconductor Corporation.
- (3) The human body model is a 100pF capacitor discharged through a 1.5k Ω resistor into each pin.

Operating Ratings⁽¹⁾

V_{IN}	8.0V to 36V
Junction Temperature	-40°C to + 125°C

- (1) Absolute Maximum Ratings are limits beyond which damage to the device may occur. Operating Ratings are conditions under which operation of the device is intended to be functional. For guaranteed specifications and test conditions, see the [Electrical Characteristics](#).

Electrical Characteristics

Specifications with standard typeface are for $T_J = 25^\circ\text{C}$, and those with **boldface** type apply over full **Operating Junction Temperature range**. $V_{IN} = 24\text{V}$, $R_{ON} = 200\text{k}$ unless otherwise stated ⁽¹⁾.

Symbol	Parameter	Conditions	Min	Typ	Max	Units
Start-Up Regulator, V_{CC}						
V_{CCReg}	V_{CC} regulated output		6.6	7	7.4	V
	V_{IN} - V_{CC} dropout voltage	$I_{CC} = 0\text{ mA}$, $V_{CC} = V_{CCReg} - 100\text{ mV}$		1.4		V
	V_{CC} output impedance	$0\text{ mA} \leq I_{CC} \leq 5\text{ mA}$		140		Ω
	V_{CC} current limit ⁽²⁾	$V_{CC} = 0\text{V}$		9		mA
$UVLO_{VCC}$	V_{CC} under-voltage lockout threshold	V_{CC} increasing		5.8		V
	$UVLO_{VCC}$ hysteresis	V_{CC} decreasing		150		mV
	$UVLO_{VCC}$ filter delay	100 mV overdrive		3		μs
	I_{IN} operating current	Non-switching, $FB = 3\text{V}$		0.63	1	mA
	I_{IN} shutdown current	$R_{ON}/SD = 0\text{V}$		80	250	μA
Switch Characteristics						
$R_{ds(on)}$	Buck Switch $R_{ds(on)}$	$I_{TEST} = 200\text{ mA}$		0.45	0.95	Ω
$UVLO_{GD}$	Gate Drive UVLO	$V_{BST} - V_{SW}$ Increasing	3.0	4.3	5.5	V
	$UVLO_{GD}$ hysteresis			440		mV
Softstart Pin						
	Pull-up voltage			2.5		V
	Internal current source			11.5		μA

- (1) Typical specifications represent the most likely parametric norm at 25°C operation.
- (2) V_{CC} provides self bias for the internal gate drive and control circuits. Device thermal limitations limit external loading

Electrical Characteristics (continued)

Specifications with standard typeface are for $T_J = 25^\circ\text{C}$, and those with **boldface** type apply over full **Operating Junction Temperature range**. $V_{IN} = 24\text{V}$, $R_{ON} = 200\text{k}$ unless otherwise stated ⁽¹⁾.

Symbol	Parameter	Conditions	Min	Typ	Max	Units
Current Limit						
I_{LIM}	Threshold	Current out of I_{SEN}	1	1.25	1.5	A
	Resistance from I_{SEN} to S_{GND}			130		m Ω
	Response time			150		ns
On Timer						
$t_{ON} - 1$	On-time	$V_{IN} = 10\text{V}$, $R_{ON} = 200\text{k}\Omega$	2.1	2.75	3.6	μs
$t_{ON} - 2$	On-time	$V_{IN} = 36\text{V}$, $R_{ON} = 200\text{k}\Omega$		740		ns
	Shutdown threshold	Voltage at R_{ON}/SD rising	0.35	0.65	1.1	V
	Threshold hysteresis	Voltage at R_{ON}/SD falling		40		mV
Off Timer						
t_{OFF}	Minimum Off-time			280		ns
Regulation and Over-Voltage Comparators (FB Pin)						
V_{REF}	FB regulation threshold	SS pin = steady state	2.440	2.5	2.550	V
	FB over-voltage threshold			2.875		V
	FB bias current			100		nA
Thermal Shutdown						
T_{SD}	Thermal shutdown temperature			175		$^\circ\text{C}$
	Thermal shutdown hysteresis			20		$^\circ\text{C}$

Typical Performance Characteristics

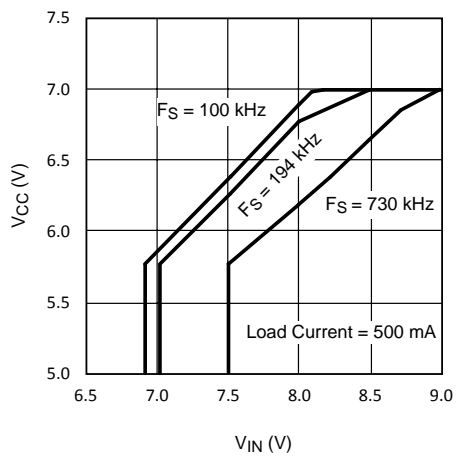

Figure 2. V_{CC} vs V_{IN}

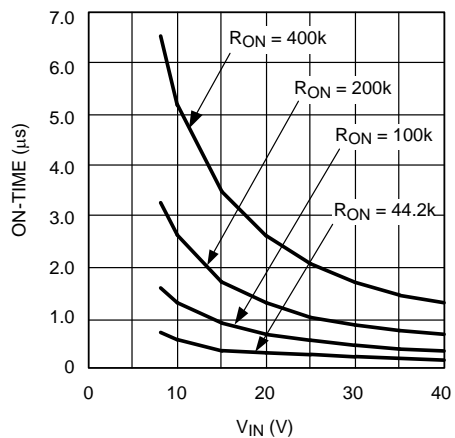

Figure 3. ON-Time vs V_{IN} and R_{ON}

Functional Description

The LM34910 Step Down Switching Regulator features all the functions needed to implement a low cost, efficient buck bias power converter capable of supplying 1.25A to the load. This high voltage regulator contains a 40V N-Channel buck switch, is easy to implement, and is available in the thermally enhanced WSON-10 package. The regulator's operation is based on a hysteretic control scheme, and uses an on-time control which varies inversely with V_{IN} . This feature allows the operating frequency to remain relatively constant with load and input voltage variations. The hysteretic control requires no loop compensation resulting in very fast load transient response. The valley current limit detection circuit, internally set at 1.25A, holds the buck switch off until the high current level subsides. The functional block diagram is shown in [Typical Application Circuit and Block Diagram](#).

The LM34910 can be applied in numerous applications to efficiently regulate down higher voltages. Additional features include: Thermal shutdown, V_{CC} under-voltage lockout, gate drive under-voltage lockout, and maximum duty cycle limiter.

Hysteretic Control Circuit Overview

The LM34910 buck DC-DC regulator employs a control scheme based on a comparator and a one-shot on-timer, with the output voltage feedback (FB) compared to an internal reference (2.5V). If the FB voltage is below the reference the buck switch is turned on for a time period determined by the input voltage and a programming resistor (R_{ON}). Following the on-time the switch remains off for a minimum of 280 ns, and until the FB voltage falls below the reference. The buck switch then turns on for another on-time period. Typically, during start-up, or when the load current increases suddenly, the off-times are at the minimum of 280 ns. Once regulation is established, the off-times are longer.

When in regulation, the LM34910 operates in continuous conduction mode at heavy load currents and discontinuous conduction mode at light load currents. In continuous conduction mode current always flows through the inductor, never reaching zero during the off-time. In this mode the operating frequency remains relatively constant with load and line variations. The minimum load current for continuous conduction mode is one-half the inductor's ripple current amplitude. The operating frequency is approximately:

$$F_s = \frac{V_{OUT}}{1.3 \times 10^{-10} \times R_{ON}} \quad (1)$$

The buck switch duty cycle is equal to :

$$DC = \frac{t_{ON}}{t_{ON} + t_{OFF}} = \frac{V_{OUT}}{V_{IN}} \quad (2)$$

In discontinuous conduction mode current through the inductor ramps up from zero to a peak during the on-time, then ramps back to zero before the end of the off-time. The next on-time period starts when the voltage at FB falls below the reference - until then the inductor current remains zero, and the load current is supplied by the output capacitor (C2). In this mode the operating frequency is lower than in continuous conduction mode, and varies with load current. Conversion efficiency is maintained at light loads since the switching losses reduce with the reduction in load and frequency. The approximate discontinuous operating frequency can be calculated as follows:

$$F_s = \frac{V_{OUT}^2 \times L1 \times 1.18 \times 10^{20}}{R_L \times (R_{ON})^2}$$

where

- R_L = the load resistance (3)

The output voltage is set by two external resistors (R1, R2). The regulated output voltage is calculated as follows:

$$V_{OUT} = 2.5 \times (R1 + R2) / R2 \quad (4)$$

Output voltage regulation is based on ripple voltage at the feedback input, requiring a minimum amount of ESR for the output capacitor C2. The LM34910 requires a minimum of 25 mV of ripple voltage at the FB pin. In cases where the capacitor's ESR is insufficient additional series resistance may be required (R3 in [Typical Application Circuit and Block Diagram](#)).

For applications where lower output voltage ripple is required the output can be taken directly from a low ESR output capacitor as shown in [Figure 4](#). However, R3 slightly degrades the load regulation.

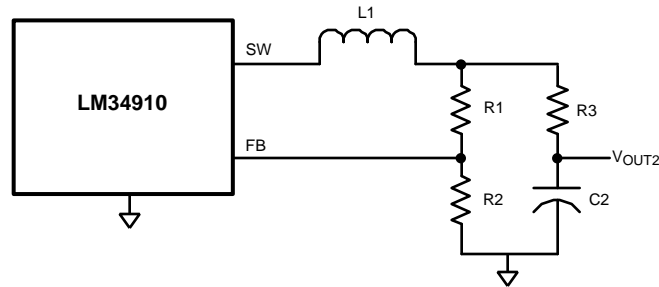

Figure 4. Low Ripple Output Configuration

Start-up Regulator, V_{CC}

The start-up regulator is integral to the LM34910. The input pin (V_{IN}) can be connected directly to line voltage up to 36V, with transient capability to 40V. The V_{CC} output regulates at 7.0V, and is current limited to 9 mA. Upon power up, the regulator sources current into the external capacitor at V_{CC} (C3). When the voltage on the V_{CC} pin reaches the under-voltage lockout threshold of 5.8V, the buck switch is enabled and the Softstart pin is released to allow the Softstart capacitor (C6) to charge up.

The minimum input voltage is determined by the regulator's dropout voltage, the V_{CC} UVLO falling threshold (≈5.7V), and the frequency. When V_{CC} falls below the falling threshold the V_{CC} UVLO activates to shut off the output. If V_{CC} is externally loaded, the minimum input voltage increases since the output impedance at V_{CC} is ≈140Ω. See [Figure 2](#).

To reduce power dissipation in the start-up regulator, an auxiliary voltage can be diode connected to the V_{CC} pin. Setting the auxiliary voltage to between 8V and 14V shuts off the internal regulator, reducing internal power dissipation. The sum of the auxiliary voltage and the input voltage (V_{CC} + V_{IN}) cannot exceed 50V. Internally, a diode connects V_{CC} to V_{IN}. See [Figure 5](#).

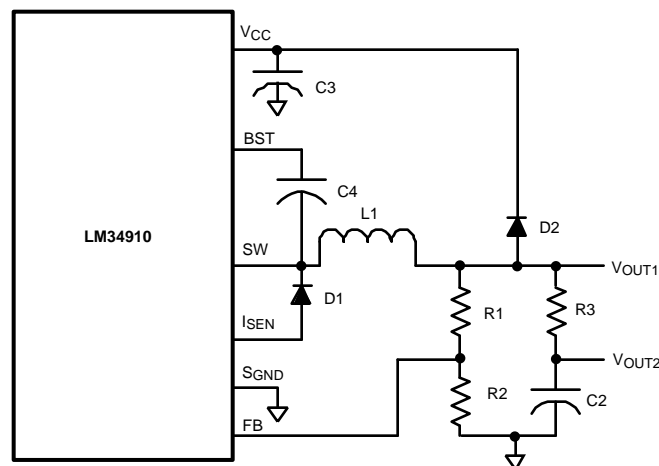

Figure 5. Self Biased Configuration

Regulation Comparator

The feedback voltage at FB is compared to the voltage at the Softstart pin (2.5V). In normal operation (the output voltage is regulated), an on-time period is initiated when the voltage at FB falls below 2.5V. The buck switch stays on for the on-time, causing the FB voltage to rise above 2.5V. After the on-time period, the buck switch stays off until the FB voltage falls below 2.5V. Bias current at the FB pin is nominally 100 nA.

Over-Voltage Comparator

The voltage at FB is compared to an internal 2.875V reference. If the voltage at FB rises above 2.875V the on-time pulse is immediately terminated. This condition can occur if the input voltage or the output load changes suddenly, or if the inductor (L1) saturates. The buck switch remains off until the voltage at FB falls below 2.5V.

ON-Time Timer, and Shutdown

The on-time for the LM34910 is determined by the R_{ON} resistor and the input voltage (V_{IN}), and is calculated from:

$$t_{ON} = \frac{1.3 \times 10^{-10} \times R_{ON}}{V_{IN}} \quad (5)$$

See [Figure 3](#). The inverse relationship with V_{IN} results in a nearly constant frequency as V_{IN} is varied. R_{ON} should be selected for a minimum on-time (at maximum V_{IN}) greater than 200 ns. This requirement limits the maximum frequency for each application, depending on V_{IN} and V_{OUT} , calculated from the following:

$$F_{MAX} = \frac{V_{OUT}}{V_{INMAX} \times 200 \text{ ns}} \quad (6)$$

The LM34910 can be remotely shut down by taking the R_{ON}/SD pin below 0.65V. See [Figure 6](#). In this mode the SS pin is internally grounded, the on-timer is disabled, and bias currents are reduced. Releasing the R_{ON}/SD pin allows normal operation to resume. The voltage at the R_{ON}/SD pin is between 1.5V and 3.0V, depending on V_{IN} and the R_{ON} resistor.

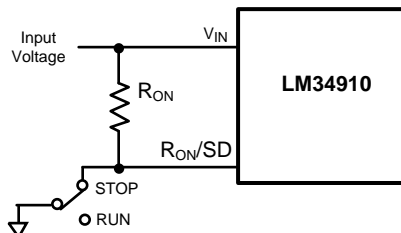

Figure 6. Shutdown Implementation

Current Limit

Current limit detection occurs during the off-time by monitoring the recirculating current through the free-wheeling diode (D1). Referring to [Typical Application Circuit and Block Diagram](#), when the buck switch is turned off the inductor current flows through the load, into S_{GND} , through the sense resistor, out of I_{SEN} and through D1. If that current exceeds 1.25A the current limit comparator output switches to delay the start of the next on-time period if the voltage at FB is below 2.5V. The next on-time starts when the current out of I_{SEN} is below 1.25A and the voltage at FB is below 2.5V. If the overload condition persists causing the inductor current to exceed 1.25A during each on-time, that is detected at the beginning of each off-time. The operating frequency may be lower due to longer-than-normal off-times.

Figure 7 illustrates the inductor current waveform. During normal operation the load current is I_O , the average of the ripple waveform. When the load resistance decreases the current ratchets up until the lower peak reaches 1.25A. During the Current Limited portion of Figure 7, the current ramps down to 1.25A during each off-time, initiating the next on-time (assuming the voltage at FB is $<2.5V$). During each on-time the current ramps up an amount equal to:

$$\Delta I = (V_{IN} - V_{OUT}) \times t_{ON} / L1 \quad (7)$$

During this time the LM34910 is in a constant current mode, with an average load current (I_{OCL}) equal to $1.25A + \Delta I/2$.

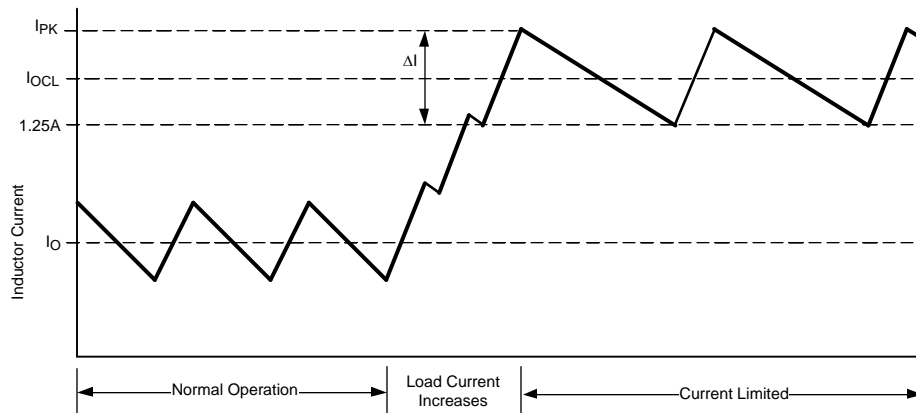

Figure 7. Inductor Current - Current Limit Operation

The current limit threshold can be increased by connecting an external resistor between S_{GND} and I_{SEN} . The external resistor will typically be less than 1Ω. The peak current out of SW and I_{SEN} must not exceed 3.5A. The average current out of SW must be less than 3A, and the average current out of I_{SEN} must be less than 2A. Therefore I_{PK} in Figure 7 must not exceed 3.5A, and I_{OCL} must not exceed 2A.

N - Channel Buck Switch and Driver

The LM34910 integrates an N-Channel buck switch and associated floating high voltage gate driver. The peak current allowed through the buck switch is 3.5A, and the maximum allowed average current is 3A. The gate driver circuit works in conjunction with an external bootstrap capacitor and an internal high voltage diode. A 0.022 μF capacitor (C4) connected between BST and SW provides the voltage to the driver during the on-time. During each off-time, the SW pin is at approximately -1V, and C4 charges from V_{CC} through the internal diode. The minimum off-time of 280 ns ensures a minimum time each cycle to recharge the bootstrap capacitor.

Softstart

The softstart feature allows the converter to gradually reach a steady state operating point, thereby reducing start-up stresses and current surges. Upon turn-on, after V_{CC} reaches the under-voltage threshold, an internal 11.5 μA current source charges up the external capacitor at the SS pin to 2.5V. The ramping voltage at SS (and the non-inverting input of the regulation comparator) ramps up the output voltage in a controlled manner.

An internal switch grounds the SS pin if V_{CC} is below the under-voltage lockout threshold, if a thermal shutdown occurs, or if the R_{ON}/SD pin is grounded.

Thermal Shutdown

The LM34910 should be operated so the junction temperature does not exceed 125°C. If the junction temperature increases, an internal Thermal Shutdown circuit, which activates (typically) at 175°C, takes the controller to a low power reset state by disabling the buck switch and the on-timer, and grounding the Softstart pin. This feature helps prevent catastrophic failures from accidental device overheating. When the junction temperature reduces below 155°C (typical hysteresis = 20°C), the Softstart pin is released and normal operation resumes.

APPLICATIONS INFORMATION

EXTERNAL COMPONENTS

The following guidelines can be used to select the external components.

R1 and R2: The ratio of these resistors is calculated from:

$$R1/R2 = (V_{OUT}/2.5V) - 1 \quad (8)$$

R1 and R2 should be chosen from standard value resistors in the range of 1.0 k Ω - 10 k Ω which satisfy the above ratio.

R_{ON}: The minimum value for R_{ON} is calculated from:

$$R_{ON} \geq \frac{200 \text{ ns} \times V_{INMAX}}{1.3 \times 10^{-10}} \quad (9)$$

[Equation 1](#) can be used to select R_{ON} if a specific frequency is desired as long as the above limitation is met.

L1: The main parameter affected by the inductor is the output current ripple amplitude (I_{OR}). The limits for I_{OR} must be determined at both the minimum and maximum nominal load currents.

a) If the maximum load current is less than the current limit threshold (1.25A), the minimum load current is used to determine the maximum allowable ripple. To maintain continuous conduction mode the lower peak should not reach 0 mA. For this case, the maximum ripple current is:

$$I_{OR(MAX1)} = 2 \times I_{O(min)} \quad (10)$$

The ripple calculated in [Equation 10](#) is then used in the following equation:

$$L1 = \frac{V_{OUT} \times (V_{IN} - V_{OUT})}{I_{OR} \times F_S \times V_{IN}} \quad (11)$$

where V_{IN} is the maximum input voltage and F_s is determined from [Equation 1](#). This provides a minimum value for L1. The next larger standard value should be used, and L1 should be rated for the I_{PK} current level.

b) If the maximum load current is greater than the current limit threshold (1.25A), the LM34910 ensures the lower peak reaches 1.25A each cycle, requiring that I_{OR} be at least twice the difference. The upper peak, however, must not exceed 3.5A. For this case, the ripple limits are:

$$I_{OR(MAX2)} = 2 \times (3.5A - I_{O(max)}) \quad (12)$$

and

$$I_{OR(MIN1)} = 2 \times (I_{O(max)} - 1.25A) \quad (13)$$

The lesser of [Equation 12](#) and [Equation 13](#) is then used in [Equation 11](#). If I_{OR(MAX2)} is used, the maximum V_{IN} is used in [Equation 11](#). The next larger value should then be used for L1. If I_{OR(MIN1)} is used, the minimum V_{IN} is used in [Equation 11](#). The next smaller value should then be used for L1. L1 must be rated for the peak value of the current waveform (I_{PK} in [Figure 7](#)).

C3: The capacitor on the V_{CC} output provides not only noise filtering and stability, but also prevents false triggering of the V_{CC} UVLO at the buck switch on/off transitions. For this reason, C3 should be no smaller than 0.1 μ F, and should be a good quality, low ESR, ceramic capacitor.

C2, and R3: Since the LM34910 requires a minimum of 25 mV_{p-p} of ripple at the FB pin for proper operation, the required ripple at V_{OUT1} is increased by R1 and R2. This necessary ripple is created by the inductor ripple current acting on C2's ESR + R3. The minimum ripple current is calculated using [Equation 11](#), rearranged to solve for I_{OR} at minimum V_{IN}. The minimum ESR for C2 is then equal to:

$$ESR_{(min)} = \frac{25 \text{ mV} \times (R1 + R2)}{R2 \times I_{OR(min)}} \quad (14)$$

If the capacitor used for C2 does not have sufficient ESR, R3 is added in series as shown in [Typical Application Circuit and Block Diagram](#). Generally R3 is less than 1Ω. C2 should generally be no smaller than 3.3 μF, although that is dependent on the frequency and the allowable ripple amplitude at V_{OUT1}. Experimentation is usually necessary to determine the minimum value for C2, as the nature of the load may require a larger value. A load which creates significant transients requires a larger value for C2 than a non-varying load.

D1: The important parameters are reverse recovery time and forward voltage. The reverse recovery time determines how long the reverse current surge lasts each time the buck switch is turned on. The forward voltage drop is significant in the event the output is short-circuited as it is mainly this diode's voltage (plus the voltage across the current limit sense resistor) which forces the inductor current to decrease during the off-time. For this reason, a higher voltage is better, although that affects efficiency. A reverse recovery time of ≈30 ns, and a forward voltage drop of ≈0.75V are preferred. The reverse leakage specification is important as that can significantly affect efficiency. D1's reverse voltage rating must be at least as great as the maximum V_{IN}, and its current rating must equal or exceed I_{PK} [Figure 7](#).

C1 and C5: C1's purpose is to supply most of the switch current during the on-time, and limit the voltage ripple at V_{IN}, on the assumption that the voltage source feeding V_{IN} has an output impedance greater than zero. If the source's dynamic impedance is high (effectively a current source), it supplies the average input current, but not the ripple current.

At maximum load current, when the buck switch turns on, the current into V_{IN} suddenly increases to the lower peak of the inductor's ripple current, ramps up to the peak value, then drop to zero at turn-off. The average current during the on-time is the load current. For a worst case calculation, C1 must supply this average load current during the maximum on-time. C1 is calculated from:

$$C1 = \frac{I_o \times t_{ON}}{\Delta V} \quad (15)$$

where I_o is the load current, t_{ON} is the maximum on-time, and ΔV is the allowable ripple voltage at V_{IN}. C5's purpose is to help avoid transients and ringing due to long lead inductance at V_{IN}. A low ESR, 0.1 μF ceramic chip capacitor is recommended, located close to the LM34910 .

C4: The recommended value for C4 is 0.022 μF. A high quality ceramic capacitor with low ESR is recommended as C4 supplies a surge current to charge the buck switch gate at turn-on. A low ESR also helps ensure a complete recharge during each off-time.

C6: The capacitor at the SS pin determines the softstart time, i.e. the time for the reference voltage at the regulation comparator, and the output voltage, to reach their final value. The time is determined from the following:

$$t_{SS} = \frac{C6 \times 2.5V}{11.5 \mu A} \quad (16)$$

PC BOARD LAYOUT

The LM34910 regulation, over-voltage, and current limit comparators are very fast, and respond to short duration noise pulses. Layout considerations are therefore critical for optimum performance. The layout must be as neat and compact as possible, and all of the components must be as close as possible to their associated pins. The current loop formed by D1, L1, C2 and the S_{GND} and I_{SEN} pins should be as small as possible. The ground connection from C2 to C1 should be as short and direct as possible.

If it is expected that the internal dissipation of the LM34910 will produce excessive junction temperatures during normal operation, good use of the PC board's ground plane can help considerably to dissipate heat. The exposed pad on the bottom of the IC package can be soldered to a ground plane, and that plane should extend out from beneath the IC, and be connected to ground plane on the board's other side with several vias, to help dissipate the heat. The exposed pad is internally connected to the IC substrate. Additionally the use of wide PC board traces, where possible, can help conduct heat away from the IC. Judicious positioning of the PC board within the end product, along with the use of any available air flow (forced or natural convection) can help reduce the junction temperatures.

REVISION HISTORY

Changes from Revision A (March 2013) to Revision B	Page
• Changed layout of National Data Sheet to TI format	11

PACKAGING INFORMATION

Orderable Device	Status (1)	Package Type	Package Drawing	Pins	Package Qty	Eco Plan (2)	Lead/Ball Finish (6)	MSL Peak Temp (3)	Op Temp (°C)	Device Marking (4/5)	Samples
LM34910SD/NOPB	ACTIVE	WSON	DPR	10	1000	Green (RoHS & no Sb/Br)	CU SN	Level-1-260C-UNLIM	-40 to 125	34910SD	Samples
LM34910SDX/NOPB	ACTIVE	WSON	DPR	10	4500	Green (RoHS & no Sb/Br)	CU SN	Level-1-260C-UNLIM	-40 to 125	34910SD	Samples

(1) The marketing status values are defined as follows:

ACTIVE: Product device recommended for new designs.

LIFEBUY: TI has announced that the device will be discontinued, and a lifetime-buy period is in effect.

NRND: Not recommended for new designs. Device is in production to support existing customers, but TI does not recommend using this part in a new design.

PREVIEW: Device has been announced but is not in production. Samples may or may not be available.

OBSELETE: TI has discontinued the production of the device.

(2) Eco Plan - The planned eco-friendly classification: Pb-Free (RoHS), Pb-Free (RoHS Exempt), or Green (RoHS & no Sb/Br) - please check <http://www.ti.com/productcontent> for the latest availability information and additional product content details.

TBD: The Pb-Free/Green conversion plan has not been defined.

Pb-Free (RoHS): TI's terms "Lead-Free" or "Pb-Free" mean semiconductor products that are compatible with the current RoHS requirements for all 6 substances, including the requirement that lead not exceed 0.1% by weight in homogeneous materials. Where designed to be soldered at high temperatures, TI Pb-Free products are suitable for use in specified lead-free processes.

Pb-Free (RoHS Exempt): This component has a RoHS exemption for either 1) lead-based flip-chip solder bumps used between the die and package, or 2) lead-based die adhesive used between the die and leadframe. The component is otherwise considered Pb-Free (RoHS compatible) as defined above.

Green (RoHS & no Sb/Br): TI defines "Green" to mean Pb-Free (RoHS compatible), and free of Bromine (Br) and Antimony (Sb) based flame retardants (Br or Sb do not exceed 0.1% by weight in homogeneous material)

(3) MSL, Peak Temp. - The Moisture Sensitivity Level rating according to the JEDEC industry standard classifications, and peak solder temperature.

(4) There may be additional marking, which relates to the logo, the lot trace code information, or the environmental category on the device.

(5) Multiple Device Markings will be inside parentheses. Only one Device Marking contained in parentheses and separated by a "~" will appear on a device. If a line is indented then it is a continuation of the previous line and the two combined represent the entire Device Marking for that device.

(6) Lead/Ball Finish - Orderable Devices may have multiple material finish options. Finish options are separated by a vertical ruled line. Lead/Ball Finish values may wrap to two lines if the finish value exceeds the maximum column width.

Important Information and Disclaimer: The information provided on this page represents TI's knowledge and belief as of the date that it is provided. TI bases its knowledge and belief on information provided by third parties, and makes no representation or warranty as to the accuracy of such information. Efforts are underway to better integrate information from third parties. TI has taken and continues to take reasonable steps to provide representative and accurate information but may not have conducted destructive testing or chemical analysis on incoming materials and chemicals. TI and TI suppliers consider certain information to be proprietary, and thus CAS numbers and other limited information may not be available for release.

In no event shall TI's liability arising out of such information exceed the total purchase price of the TI part(s) at issue in this document sold by TI to Customer on an annual basis.

TAPE AND REEL INFORMATION



QUADRANT ASSIGNMENTS FOR PIN 1 ORIENTATION IN TAPE



*All dimensions are nominal

Device	Package Type	Package Drawing	Pins	SPQ	Reel Diameter (mm)	Reel Width W1 (mm)	A0 (mm)	B0 (mm)	K0 (mm)	P1 (mm)	W (mm)	Pin1 Quadrant
LM34910SD/NOPB	WSON	DPR	10	1000	178.0	12.4	4.3	4.3	1.3	8.0	12.0	Q1
LM34910SDX/NOPB	WSON	DPR	10	4500	330.0	12.4	4.3	4.3	1.3	8.0	12.0	Q1

TAPE AND REEL BOX DIMENSIONS

*All dimensions are nominal

Device	Package Type	Package Drawing	Pins	SPQ	Length (mm)	Width (mm)	Height (mm)
LM34910SD/NOPB	WSON	DPR	10	1000	210.0	185.0	35.0
LM34910SDX/NOPB	WSON	DPR	10	4500	367.0	367.0	35.0

IMPORTANT NOTICE

Texas Instruments Incorporated (TI) reserves the right to make corrections, enhancements, improvements and other changes to its semiconductor products and services per JESD46, latest issue, and to discontinue any product or service per JESD48, latest issue. Buyers should obtain the latest relevant information before placing orders and should verify that such information is current and complete.

TI's published terms of sale for semiconductor products (<http://www.ti.com/sc/docs/stdterms.htm>) apply to the sale of packaged integrated circuit products that TI has qualified and released to market. Additional terms may apply to the use or sale of other types of TI products and services.

Reproduction of significant portions of TI information in TI data sheets is permissible only if reproduction is without alteration and is accompanied by all associated warranties, conditions, limitations, and notices. TI is not responsible or liable for such reproduced documentation. Information of third parties may be subject to additional restrictions. Resale of TI products or services with statements different from or beyond the parameters stated by TI for that product or service voids all express and any implied warranties for the associated TI product or service and is an unfair and deceptive business practice. TI is not responsible or liable for any such statements.

Buyers and others who are developing systems that incorporate TI products (collectively, "Designers") understand and agree that Designers remain responsible for using their independent analysis, evaluation and judgment in designing their applications and that Designers have full and exclusive responsibility to assure the safety of Designers' applications and compliance of their applications (and of all TI products used in or for Designers' applications) with all applicable regulations, laws and other applicable requirements. Designer represents that, with respect to their applications, Designer has all the necessary expertise to create and implement safeguards that (1) anticipate dangerous consequences of failures, (2) monitor failures and their consequences, and (3) lessen the likelihood of failures that might cause harm and take appropriate actions. Designer agrees that prior to using or distributing any applications that include TI products, Designer will thoroughly test such applications and the functionality of such TI products as used in such applications.

TI's provision of technical, application or other design advice, quality characterization, reliability data or other services or information, including, but not limited to, reference designs and materials relating to evaluation modules, (collectively, "TI Resources") are intended to assist designers who are developing applications that incorporate TI products; by downloading, accessing or using TI Resources in any way, Designer (individually or, if Designer is acting on behalf of a company, Designer's company) agrees to use any particular TI Resource solely for this purpose and subject to the terms of this Notice.

TI's provision of TI Resources does not expand or otherwise alter TI's applicable published warranties or warranty disclaimers for TI products, and no additional obligations or liabilities arise from TI providing such TI Resources. TI reserves the right to make corrections, enhancements, improvements and other changes to its TI Resources. TI has not conducted any testing other than that specifically described in the published documentation for a particular TI Resource.

Designer is authorized to use, copy and modify any individual TI Resource only in connection with the development of applications that include the TI product(s) identified in such TI Resource. NO OTHER LICENSE, EXPRESS OR IMPLIED, BY ESTOPPEL OR OTHERWISE TO ANY OTHER TI INTELLECTUAL PROPERTY RIGHT, AND NO LICENSE TO ANY TECHNOLOGY OR INTELLECTUAL PROPERTY RIGHT OF TI OR ANY THIRD PARTY IS GRANTED HEREIN, including but not limited to any patent right, copyright, mask work right, or other intellectual property right relating to any combination, machine, or process in which TI products or services are used. Information regarding or referencing third-party products or services does not constitute a license to use such products or services, or a warranty or endorsement thereof. Use of TI Resources may require a license from a third party under the patents or other intellectual property of the third party, or a license from TI under the patents or other intellectual property of TI.

TI RESOURCES ARE PROVIDED "AS IS" AND WITH ALL FAULTS. TI DISCLAIMS ALL OTHER WARRANTIES OR REPRESENTATIONS, EXPRESS OR IMPLIED, REGARDING RESOURCES OR USE THEREOF, INCLUDING BUT NOT LIMITED TO ACCURACY OR COMPLETENESS, TITLE, ANY EPIDEMIC FAILURE WARRANTY AND ANY IMPLIED WARRANTIES OF MERCHANTABILITY, FITNESS FOR A PARTICULAR PURPOSE, AND NON-INFRINGEMENT OF ANY THIRD PARTY INTELLECTUAL PROPERTY RIGHTS. TI SHALL NOT BE LIABLE FOR AND SHALL NOT DEFEND OR INDEMNIFY DESIGNER AGAINST ANY CLAIM, INCLUDING BUT NOT LIMITED TO ANY INFRINGEMENT CLAIM THAT RELATES TO OR IS BASED ON ANY COMBINATION OF PRODUCTS EVEN IF DESCRIBED IN TI RESOURCES OR OTHERWISE. IN NO EVENT SHALL TI BE LIABLE FOR ANY ACTUAL, DIRECT, SPECIAL, COLLATERAL, INDIRECT, PUNITIVE, INCIDENTAL, CONSEQUENTIAL OR EXEMPLARY DAMAGES IN CONNECTION WITH OR ARISING OUT OF TI RESOURCES OR USE THEREOF, AND REGARDLESS OF WHETHER TI HAS BEEN ADVISED OF THE POSSIBILITY OF SUCH DAMAGES.

Unless TI has explicitly designated an individual product as meeting the requirements of a particular industry standard (e.g., ISO/TS 16949 and ISO 26262), TI is not responsible for any failure to meet such industry standard requirements.

Where TI specifically promotes products as facilitating functional safety or as compliant with industry functional safety standards, such products are intended to help enable customers to design and create their own applications that meet applicable functional safety standards and requirements. Using products in an application does not by itself establish any safety features in the application. Designers must ensure compliance with safety-related requirements and standards applicable to their applications. Designer may not use any TI products in life-critical medical equipment unless authorized officers of the parties have executed a special contract specifically governing such use. Life-critical medical equipment is medical equipment where failure of such equipment would cause serious bodily injury or death (e.g., life support, pacemakers, defibrillators, heart pumps, neurostimulators, and implantables). Such equipment includes, without limitation, all medical devices identified by the U.S. Food and Drug Administration as Class III devices and equivalent classifications outside the U.S.

TI may expressly designate certain products as completing a particular qualification (e.g., Q100, Military Grade, or Enhanced Product). Designers agree that it has the necessary expertise to select the product with the appropriate qualification designation for their applications and that proper product selection is at Designers' own risk. Designers are solely responsible for compliance with all legal and regulatory requirements in connection with such selection.

Designer will fully indemnify TI and its representatives against any damages, costs, losses, and/or liabilities arising out of Designer's non-compliance with the terms and provisions of this Notice.

Looking for pricing, stock, or lifecycle information?

Click below to explore more details on WIN SOURCE:

 [View LM34910SD/NOPB on WIN SOURCE](#)

 [Texas Instruments](#) Information

Optimize Your Supply Chain with WIN SOURCE Solutions

-  Global Sourcing Solution
-  Obsolete Management
-  Cost Control Management
-  Shortage Management
-  Alternative Solution
-  Excess Inventory Management