



THE DATASHEET OF LM34919TLX/NOPB



Ultra-Small 40-V 600-mA Constant On-Time Buck Switching Regulator

 Check for Samples: [LM34919](#)

FEATURES

- Integrated N-Channel buck switch
- Integrated start-up regulator
- Input Voltage Range: 8V to 40V
- No loop compensation required
- Ultra-Fast transient response
- Operating frequency remains constant with load current and input voltage
- Maximum switching frequency: 2.0 MHz
- Maximum Duty Cycle Limited During Start-Up
- Adjustable output voltage
- Valley Current Limit At 0.64A

- Precision internal reference
- Low bias current
- Highly efficient operation
- Thermal shutdown
- 10-Pin DSBGA Package

APPLICATIONS

- High Efficiency Point-Of-Load (POL) Regulator
- Non-Isolated Telecommunication Buck Regulator
- Secondary High Voltage Post Regulator

DESCRIPTION

The LM34919 Step Down Switching Regulator features all of the functions needed to implement a low cost, efficient, buck bias regulator capable of supplying 0.6A to the load. This buck regulator contains an N-Channel Buck Switch, and is available in a 10-pin DSBGA package. The constant on-time feedback regulation scheme requires no loop compensation, results in fast load transient response, and simplifies circuit implementation. The operating frequency remains constant with line and load variations due to the inverse relationship between the input voltage and the on-time. The valley current limit results in a smooth transition from constant voltage to constant current mode when current limit is detected, reducing the frequency and output voltage, without the use of foldback. Additional features include: VCC under-voltage lockout, thermal shutdown, gate drive under-voltage lockout, and maximum duty cycle limiter.

Basic Step Down Regulator

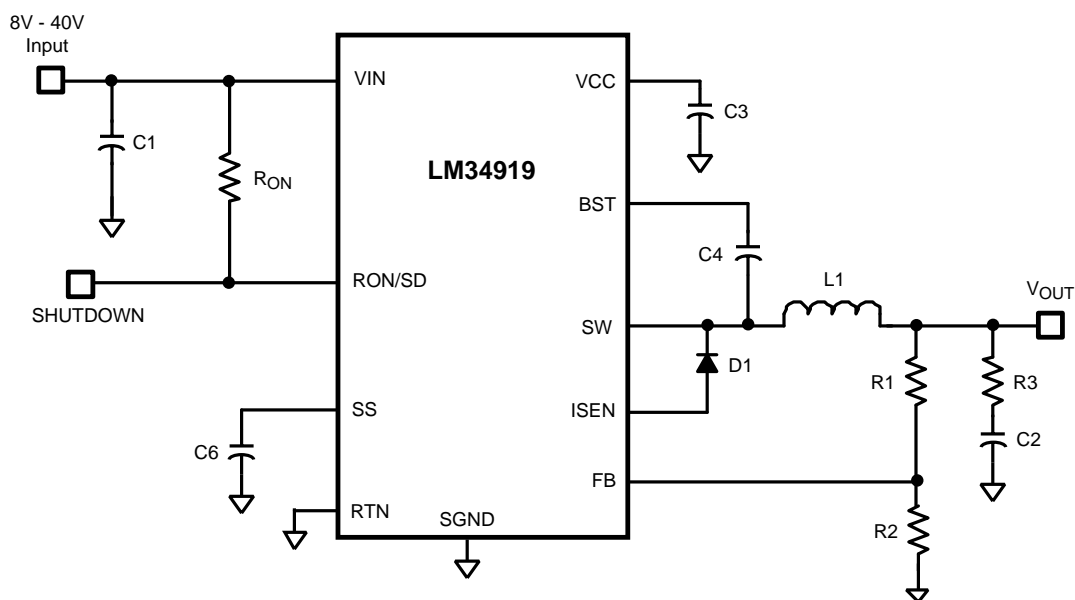

Please be aware that an important notice concerning availability, standard warranty, and use in critical applications of Texas Instruments semiconductor products and disclaimers thereto appears at the end of this data sheet.

All trademarks are the property of their respective owners.

Connection Diagram

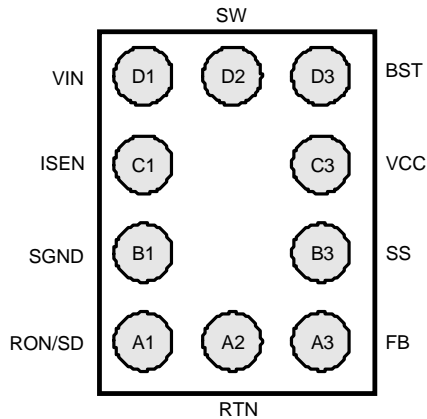

Figure 1. Bump Side

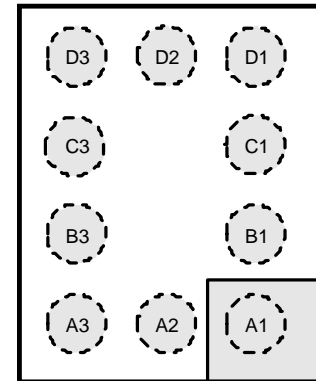

Figure 2. Top View

PIN DESCRIPTIONS

Pin No.	Name	Description	Application Information
A1	RON/SD	On-time control and shutdown	An external resistor from VIN to this pin sets the buck switch on-time. Grounding this pin shuts down the regulator.
A2	RTN	Circuit Ground	Ground for all internal circuitry other than the current limit detection.
A3	FB	Feedback input from the regulated output	Internally connected to the regulation and over-voltage comparators. The regulation level is 2.5V.
B1	SGND	Sense Ground	Re-circulating current flows into this pin to the current sense resistor.
B3	SS	Softstart	An internal current source charges an external capacitor to 2.5V, providing the softstart function.
C1	ISEN	Current sense	The re-circulating current flows through the internal sense resistor, and out of this pin to the free-wheeling diode. Current limit is nominally set at 0.64A.
C3	VCC	Output from the startup regulator	Nominally regulates at 7.0V. An external voltage (7V-14V) can be applied to this pin to reduce internal dissipation. An internal diode connects VCC to VIN.
D1	VIN	Input supply voltage	Nominal input range is 8.0V to 40V.
D2	SW	Switching Node	Internally connected to the buck switch source. Connect to the inductor, free-wheeling diode, and bootstrap capacitor.
D3	BST	Boost pin for bootstrap capacitor	Connect a 0.022 μ F capacitor from SW to this pin. The capacitor is charged from VCC via an internal diode during each off-time.



These devices have limited built-in ESD protection. The leads should be shorted together or the device placed in conductive foam during storage or handling to prevent electrostatic damage to the MOS gates.

Absolute Maximum Ratings⁽¹⁾

VIN to RTN	44V
BST to RTN	52V
SW to RTN (Steady State)	-1.5V
ESD Rating, Human Body Model ⁽²⁾	2kV
BST to VCC	44V
VIN to SW	44V
BST to SW	14V
VCC to RTN	14V
SGND to RTN	-0.3V to +0.3V
SS to RTN	-0.3V to 4V
All Other Inputs to RTN	-0.3 to 7V
Storage Temperature Range	-65°C to +150°C
Junction temperature	150°C

- (1) Absolute Maximum Ratings are limits beyond which damage to the device may occur. Operating Ratings are conditions under which operation of the device is intended to be functional. For specifications and test conditions, see the Electrical Characteristics.
- (2) The human body model is a 100pF capacitor discharged through a 1.5kΩ resistor into each pin.

Operating Ratings⁽¹⁾

VIN	8.0V to 40V
Junction Temperature	-40°C to + 125°C

- (1) Absolute Maximum Ratings are limits beyond which damage to the device may occur. Operating Ratings are conditions under which operation of the device is intended to be functional. For specifications and test conditions, see the Electrical Characteristics.

Electrical Characteristics

Specifications with standard type are for $T_J = 25^\circ\text{C}$ only; limits in **boldface** type apply over the full Operating Junction Temperature (T_J) range. Minimum and Maximum limits are specified through test, design, or statistical correlation. Typical values represent the most likely parametric norm at $T_J = 25^\circ\text{C}$, and are provided for reference purposes only. Unless otherwise stated the following conditions apply: $V_{IN} = 12\text{V}$, $R_{ON} = 200\text{k}\Omega$. See ⁽¹⁾.

Symbol	Parameter	Test Conditions	Min	Typ	Max	Unit
Start-Up Regulator, V_{CC}						
$V_{CC\text{Reg}}$	V_{CC} regulated output		6.6	7	7.4	V
	V_{IN} - V_{CC} dropout voltage	$I_{CC} = 0\text{ mA}$, $V_{CC} = UVLO_{VCC} + 250\text{ mV}$		1.2		V
	V_{CC} output impedance	$0\text{ mA} \leq I_{CC} \leq 5\text{ mA}$, $V_{IN} = 8\text{V}$		175		Ω
	V_{CC} current limit ⁽²⁾	$V_{CC} = 0\text{V}$		9.5		mA
$UVLO_{VCC}$	V_{CC} under-voltage lockout threshold	V_{CC} increasing		5.7		V
	$UVLO_{VCC}$ hysteresis	V_{CC} decreasing		150		mV
	$UVLO_{VCC}$ filter delay	100 mV overdrive		3		μs
I_Q	I_{IN} operating current	Non-switching, FB = 3V, SW = Open		0.5	0.8	mA
I_{SD}	I_{IN} shutdown current	$R_{ON}/SD = 0\text{V}$, SW = Open		75	150	μA
Switch Characteristics						
$R_{ds(on)}$	Buck Switch $R_{ds(on)}$	$I_{TEST} = 200\text{ mA}$		0.5	1.0	Ω
$UVLO_{GD}$	Gate Drive UVLO	$V_{BST} - V_{SW}$ Increasing	3.0	4.4	5.2	V
	$UVLO_{GD}$ hysteresis			480		mV
Softstart Pin						
V_{SS}	Pull-up voltage			2.5		V
	Internal current source	$V_{SS} = 1\text{V}$		10.5		μA
Current Limit						
I_{LIM}	Threshold	Current out of ISEN	0.52	0.64	0.76	A
	Resistance from ISEN to SGND			140		$\text{m}\Omega$
	Response time			150		ns
On Timer						
t_{ON-1}	On-time	$V_{IN} = 10\text{V}$, $R_{ON} = 200\text{ k}\Omega$	2.1	2.77	3.5	μs
t_{ON-2}	On-time	$V_{IN} = 40\text{V}$, $R_{ON} = 200\text{ k}\Omega$		700		ns
	Shutdown threshold	Voltage at R_{ON}/SD rising	0.45	0.8	1.2	V
	Threshold hysteresis	Voltage at R_{ON}/SD		25		mV
Off Timer						
t_{OFF}	Minimum Off-time			155		ns
Regulation and Over-Voltage Comparators (FB Pin)						
V_{REF}	FB regulation threshold	SS pin = steady state	2.440	2.5	2.550	V
	FB over-voltage threshold			2.9		V
	FB bias current	FB = 3V		1		nA
Thermal Shutdown						
T_{SD}	Thermal shutdown temperature			175		$^\circ\text{C}$
	Thermal shutdown hysteresis			20		$^\circ\text{C}$
Thermal Resistance						
θ_{JA}	Junction to Ambient	0 LFPM Air Flow		61		$^\circ\text{C}/\text{W}$

(1) Typical specifications represent the most likely parametric norm at 25°C operation.

(2) V_{CC} provides self bias for the internal gate drive and control circuits. Device thermal limitations limit external loading

Typical Performance Characteristics

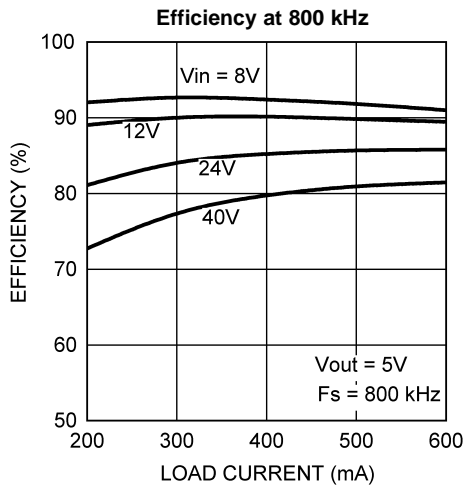

Figure 3.

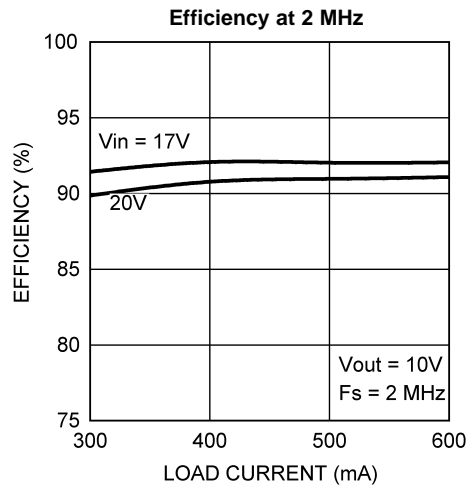

Figure 4.

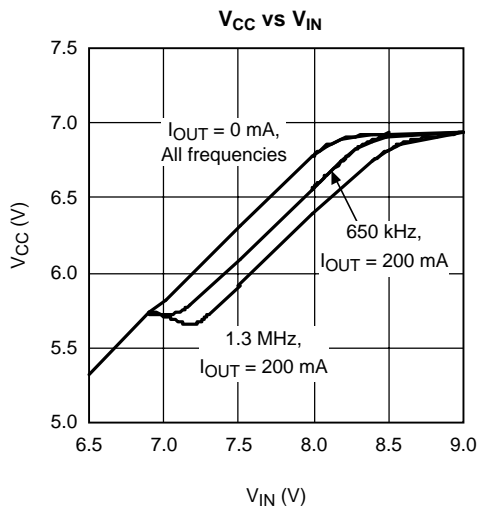

Figure 5.

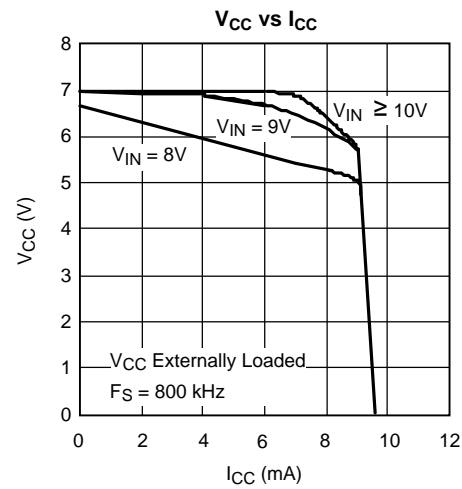

Figure 6.

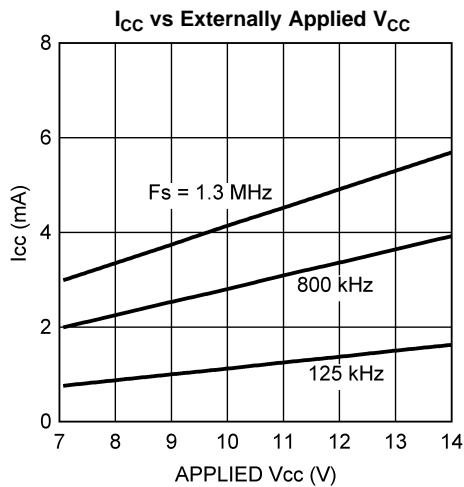

Figure 7.

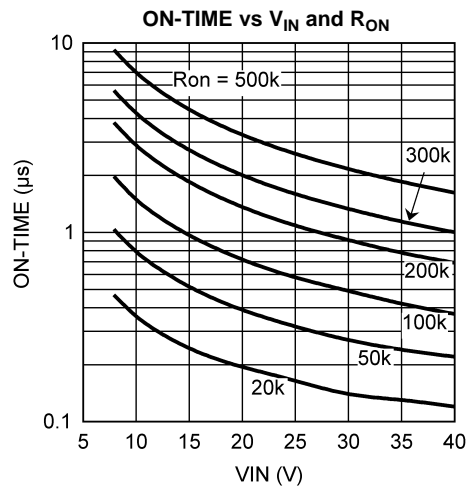

Figure 8.

Typical Performance Characteristics (continued)

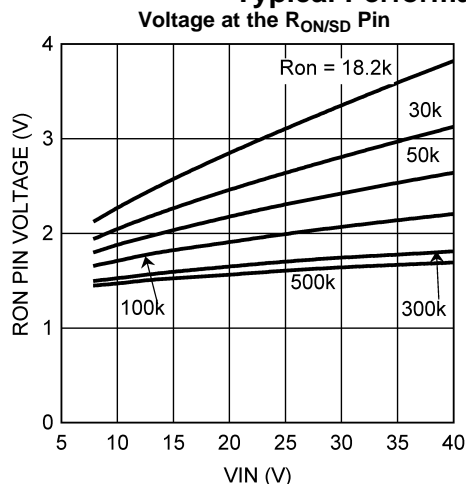

Figure 9.

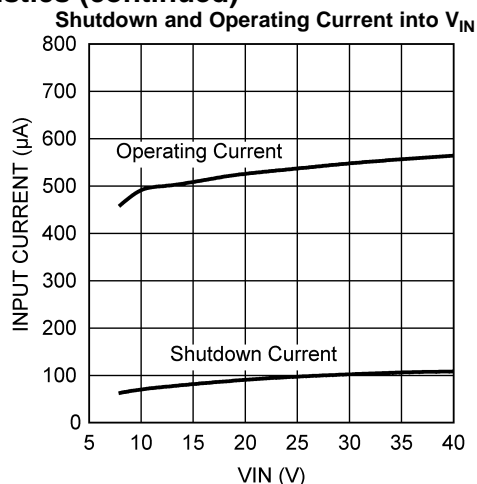
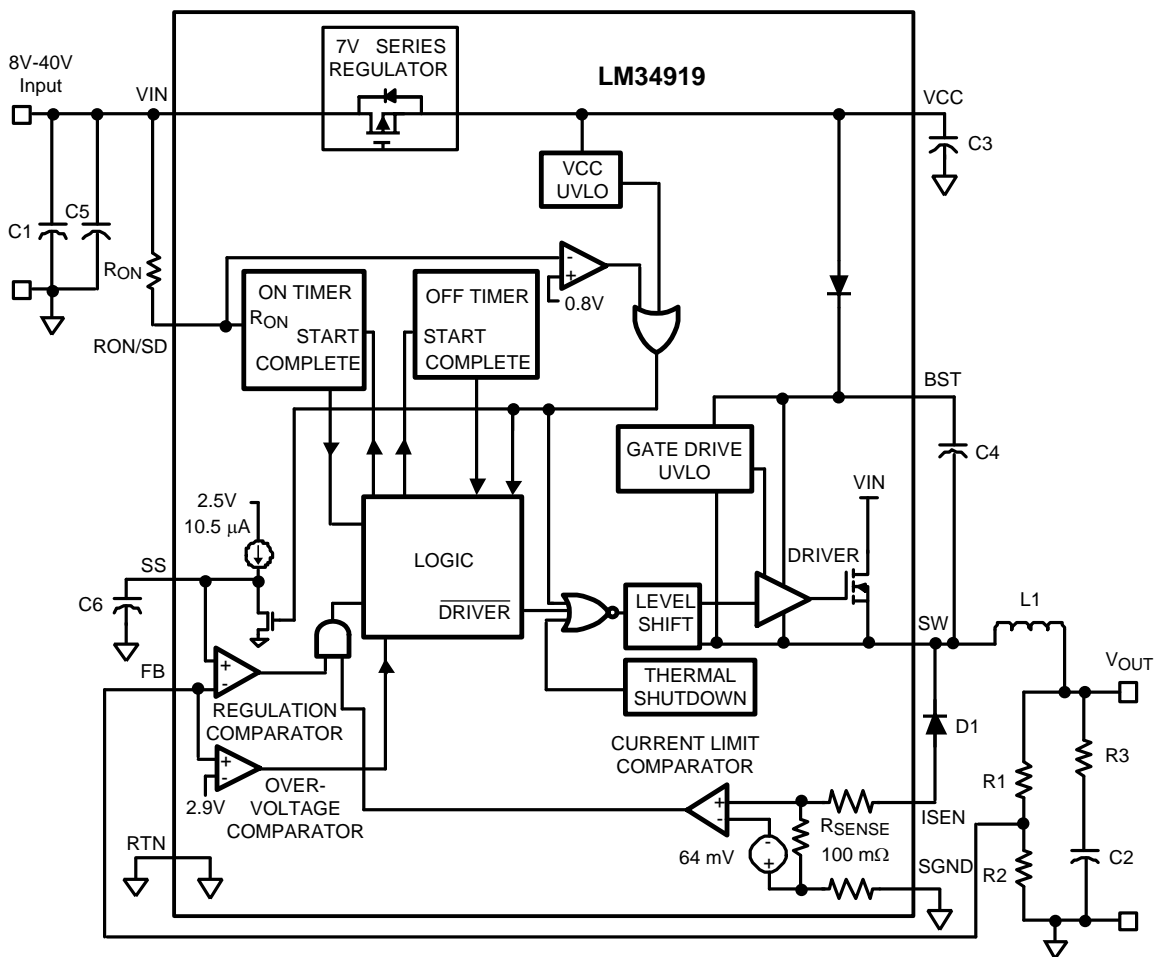

Figure 10.

TYPICAL APPLICATION CIRCUIT AND BLOCK DIAGRAM



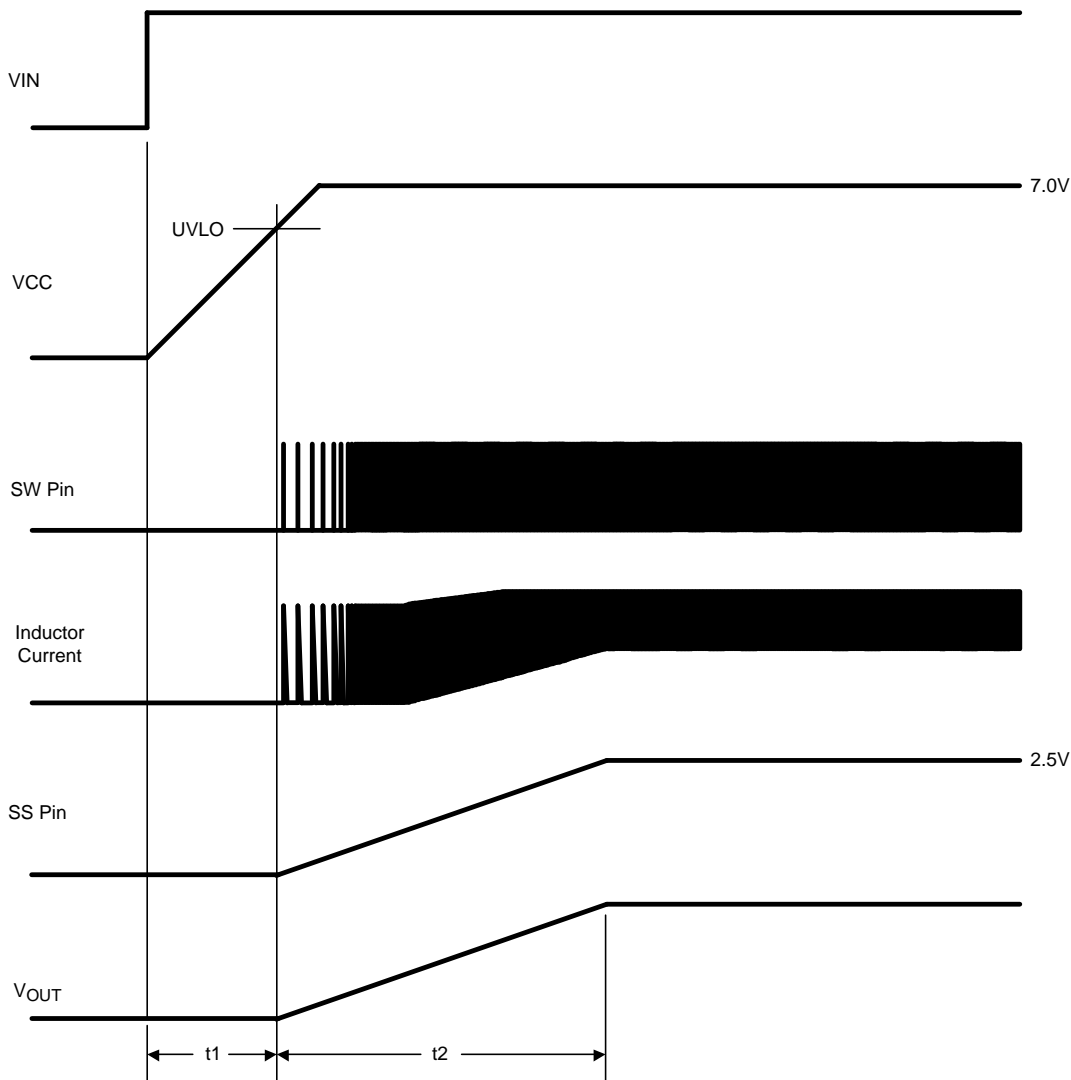

Figure 11. Start Up Sequence

FUNCTIONAL DESCRIPTION

The LM34919 Step Down Switching Regulator features all the functions needed to implement a low cost, efficient buck bias power converter capable of supplying at least 0.6A to the load. This high voltage regulator contains an N-Channel buck switch, is easy to implement, and is available in a DSBGA package. The regulator's operation is based on a constant on-time control scheme, where the on-time is determined by V_{IN} . This feature allows the operating frequency to remain relatively constant with load and input voltage variations. The feedback control requires no loop compensation resulting in very fast load transient response. The valley current limit detection circuit, internally set at 0.64A, holds the buck switch off until the high current level subsides. This scheme protects against excessively high current if the output is short-circuited when V_{IN} is high.

The LM34919 can be applied in numerous applications to efficiently regulate down higher voltages. Additional features include: Thermal shutdown, V_{CC} under-voltage lockout, gate drive under-voltage lockout, and maximum duty cycle limiter.

Control Circuit Overview

The LM34919 buck DC-DC regulator employs a control scheme based on a comparator and a one-shot on-timer, with the output voltage feedback (FB) compared to an internal reference (2.5V). If the FB voltage is below the reference the buck switch is turned on for a time period determined by the input voltage and a programming resistor (R_{ON}). Following the on-time the switch remains off until the FB voltage falls below the reference but not less than the minimum off-time. The buck switch then turns on for another on-time period. Typically, during start-up, or when the load current increases suddenly, the off-times are at the minimum. Once regulation is established, the off-times are longer.

When in regulation, the LM34919 operates in continuous conduction mode at heavy load currents and discontinuous conduction mode at light load currents. In continuous conduction mode current always flows through the inductor, never reaching zero during the off-time. In this mode the operating frequency remains relatively constant with load and line variations. The minimum load current for continuous conduction mode is one-half the inductor's ripple current amplitude. The operating frequency is approximately:

$$F_S = \frac{V_{OUT} \times (V_{IN} - 1.5V)}{1.13 \times 10^{-10} \times (R_{ON} + 1.4 \text{ k}\Omega) \times V_{IN}} \quad (1)$$

The buck switch duty cycle is approximately equal to:

$$DC = \frac{t_{ON}}{t_{ON} + t_{OFF}} = \frac{V_{OUT}}{V_{IN}} \quad (2)$$

In discontinuous conduction mode current through the inductor ramps up from zero to a peak during the on-time, then ramps back to zero before the end of the off-time. The next on-time period starts when the voltage at FB falls below the reference - until then the inductor current remains zero, and the load current is supplied by the output capacitor. In this mode the operating frequency is lower than in continuous conduction mode, and varies with load current. Conversion efficiency is maintained at light loads since the switching losses decrease with the reduction in load and frequency. The approximate discontinuous operating frequency can be calculated as follows:

$$F_S = \frac{V_{OUT}^2 \times L_1 \times 1.57 \times 10^{20}}{R_L \times (R_{ON})^2} \quad (3)$$

where R_L = the load resistance.

The output voltage is set by two external resistors (R_1 , R_2). The regulated output voltage is calculated as follows:

$$V_{OUT} = 2.5 \times (R_1 + R_2) / R_2 \quad (4)$$

Output voltage regulation is based on ripple voltage at the feedback input, normally obtained from the output voltage ripple through the feedback resistors. The LM34919 requires a minimum of 25 mV of ripple voltage at the FB pin. In cases where the capacitor's ESR is insufficient additional series resistance may be required (R_3).

Start-Up Regulator, V_{CC}

The start-up regulator is integral to the LM34919. The input pin (V_{IN}) can be connected directly to line voltage up to 40V, with transient capability to 44V. The V_{CC} output regulates at 7.0V, and is current limited at 9.5 mA. Upon power up, the regulator sources current into the external capacitor at V_{CC} (C_3). When the voltage on the V_{CC} pin reaches the under-voltage lockout threshold of 5.7V, the buck switch is enabled and the Softstart pin is released to allow the Softstart capacitor (C_6) to charge up.

The minimum input voltage is determined by the regulator's dropout voltage, the V_{CC} UVLO falling threshold ($\approx 5.55V$), and the frequency. When V_{CC} falls below the falling threshold the V_{CC} UVLO activates to shut off the output. If V_{CC} is externally loaded, the minimum input voltage increases.

To reduce power dissipation in the start-up regulator, an auxiliary voltage can be diode connected to the V_{CC} pin. Setting the auxiliary voltage to between 7V and 14V shuts off the internal regulator, reducing internal power dissipation. The sum of the auxiliary voltage and the input voltage ($V_{CC} + V_{IN}$) cannot exceed 52V. Internally, a diode connects V_{CC} to V_{IN} (see [Figure 12](#)).

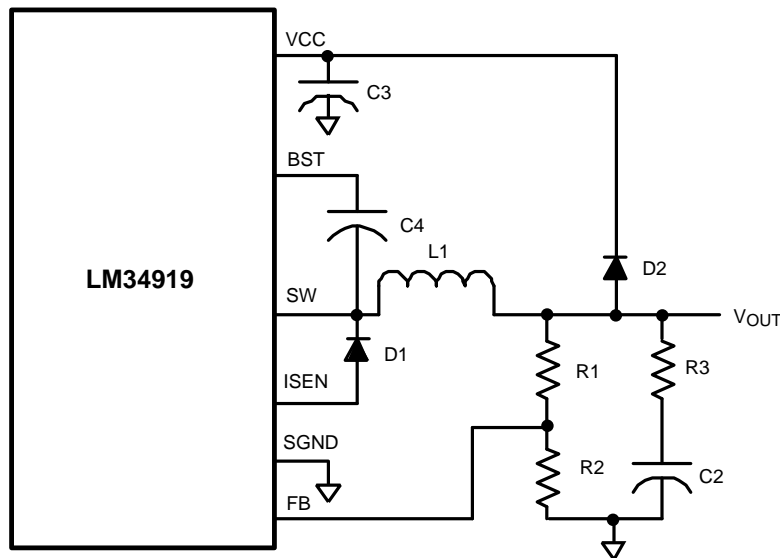

Figure 12. Self Biased Configuration

Regulation Comparator

The feedback voltage at FB is compared to the voltage at the Softstart pin (2.5V). In normal operation (the output voltage is regulated), an on-time period is initiated when the voltage at FB falls below 2.5V. The buck switch stays on for the programmed on-time, causing the FB voltage to rise above 2.5V. After the on-time period, the buck switch stays off until the FB voltage falls below 2.5V. Input bias current at the FB pin is less than 100 nA over temperature.

Over-Voltage Comparator

The voltage at FB is compared to an internal 2.9V reference. If the voltage at FB rises above 2.9V the on-time pulse is immediately terminated. This condition can occur if the input voltage or the output load changes suddenly, or if the inductor (L1) saturates. The buck switch remains off until the voltage at FB falls below 2.5V.

ON-Time Timer, and Shutdown

The on-time is determined by the R_{ON} resistor and the input voltage (V_{IN}), and is calculated from:

$$t_{ON} = \frac{1.13 \times 10^{-10} \times (R_{ON} + 1.4 \text{ k}\Omega)}{V_{IN} - 1.5\text{V}} + 100 \text{ ns} \quad (5)$$

The inverse relationship with V_{IN} results in a nearly constant frequency as V_{IN} is varied. To set a specific continuous conduction mode switching frequency (F_S), the R_{ON} resistor is determined from the following:

$$R_{ON} = \frac{V_{OUT} \times (V_{IN} - 1.5\text{V})}{F_S \times 1.13 \times 10^{-10} \times V_{IN}} - 1.4 \text{ k}\Omega \quad (6)$$

In high frequency applications the minimum value for t_{ON} is limited by the maximum duty cycle required for regulation and the minimum off-time of (155 ns, $\pm 15\%$). The minimum off-time limits the maximum duty cycle achievable with a low voltage at V_{IN} . At high values of V_{IN} , the minimum on-time is limited to ≈ 120 ns.

The LM34919 can be remotely shut down by taking the RON/SD pin below 0.8V (see Figure 13). In this mode the SS pin is internally grounded, the on-timer is disabled, and bias currents are reduced. Releasing the RON/SD pin allows normal operation to resume. The voltage at the RON/SD pin is between 1.4V and 4.0V, depending on V_{IN} and the R_{ON} resistor.

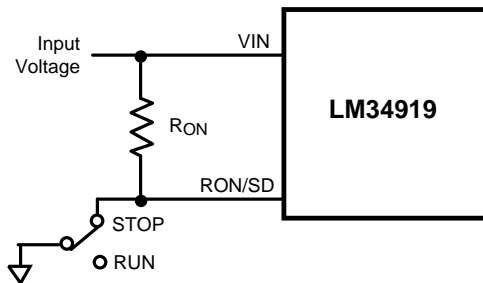

Figure 13. Shutdown Implementation

Current Limit

Current limit detection occurs during the off-time by monitoring the recirculating current through the free-wheeling diode (D1). Referring to the Block Diagram, when the buck switch is turned off the inductor current flows through the load, into SGND, through the sense resistor, out of ISEN and through D1. If that current exceeds 0.64A the current limit comparator output switches to delay the start of the next on-time period. The next on-time starts when the current out of ISEN is below 0.64A and the voltage at FB is below 2.5V. If the overload condition persists causing the inductor current to exceed 0.64A during each on-time, that is detected at the beginning of each off-time. The operating frequency is lower due to longer-than-normal off-times.

Figure 14 shows the inductor current waveform. During normal operation the load current is I_o , the average of the ripple waveform. When the load resistance decreases the current ratchets up until the lower peak reaches 0.64A. During the Current Limited portion of Figure 14, the current ramps down to 0.64A during each off-time, initiating the next on-time (assuming the voltage at FB is $<2.5V$). During each on-time the current ramps up an amount equal to:

$$\Delta I = (V_{IN} - V_{OUT}) \times t_{ON} / L1 \quad (7)$$

During this time the LM34919 is in a constant current mode, with an average load current (I_{OCL}) equal to $0.64A + \Delta I/2$.

Generally, in applications where the switching frequency is higher than ≈ 300 kHz and uses a small value inductor, the higher di/dt of the inductor's ripple current results in an effectively lower valley current limit threshold due to the response time of the current limit detection circuit. However, since the small value inductor results in a relatively high ripple current amplitude (ΔI in Figure 14), the load current (I_{OCL}) at current limit is typically in excess of 640 mA.

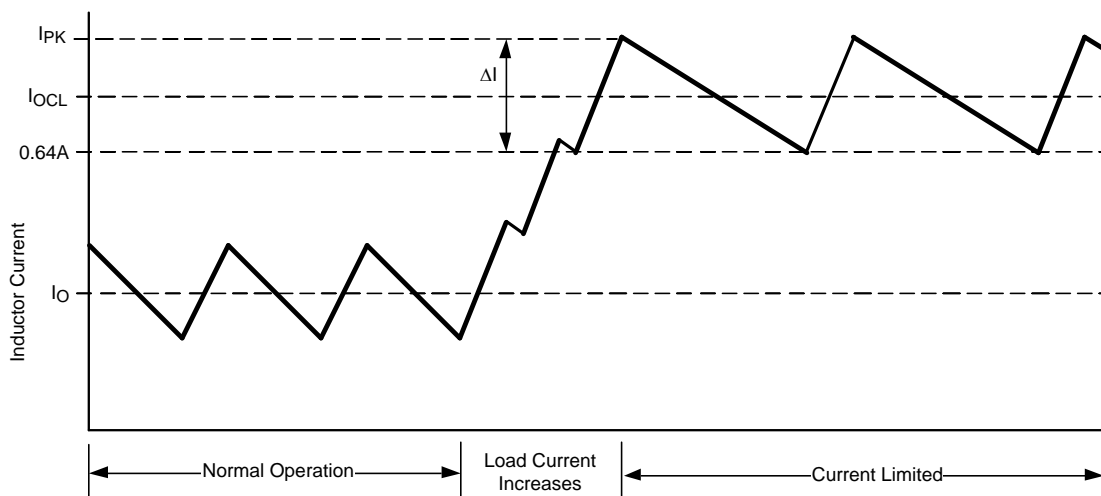

Figure 14. Inductor Current - Current Limit Operation

N-Channel Buck Switch and Driver

The LM34919 integrates an N-Channel buck switch and associated floating high voltage gate driver. The peak current allowed through the buck switch is 1.5A, and the maximum allowed average current is 1A. The gate driver circuit works in conjunction with an external bootstrap capacitor and an internal high voltage diode. A 0.022 μ F capacitor (C4) connected between BST and SW provides the voltage to the driver during the on-time. During each off-time, the SW pin is at approximately -1V, and C4 charges from V_{CC} through the internal diode. The minimum off-time forced by the LM34919 ensures a minimum time each cycle to recharge the bootstrap capacitor.

Softstart

The softstart feature allows the converter to gradually reach a steady state operating point, thereby reducing start-up stresses and current surges. Upon turn-on, after V_{CC} reaches the under-voltage threshold, an internal 10.5 μ A current source charges up the external capacitor at the SS pin to 2.5V. The ramping voltage at SS (and the non-inverting input of the regulation comparator) ramps up the output voltage in a controlled manner.

An internal switch grounds the SS pin if V_{CC} is below the under-voltage lockout threshold, or if the RON/SD pin is grounded.

Thermal Shutdown

The LM34919 should be operated so the junction temperature does not exceed 125°C. If the junction temperature increases, an internal Thermal Shutdown circuit, which activates (typically) at 175°C, takes the controller to a low power reset state by disabling the buck switch. This feature helps prevent catastrophic failures from accidental device overheating. When the junction temperature reduces below 155°C (typical hysteresis = 20°C) normal operation resumes.

APPLICATIONS INFORMATION

EXTERNAL COMPONENTS

The procedure for calculating the external components is illustrated with the following design example. Referring to the Block Diagram, the circuit is to be configured for the following specifications:

- $V_{OUT} = 5V$
- $V_{IN} = 8V$ to $40V$
- Minimum load current = 200 mA
- Maximum load current = 600 mA
- Switching Frequency = 800 kHz
- Soft-start time = 5 ms

R1 and R2: These resistors set the output voltage. The ratio of the feedback resistors is calculated from:

$$R1/R2 = (V_{OUT}/2.5V) - 1 \quad (8)$$

For this example, $R1/R2 = 1$. R1 and R2 should be chosen from standard value resistors in the range of 1.0 k Ω to 10 k Ω which satisfy the above ratio. For this example, 2.49k Ω is chosen for R1 and R2.

R_{ON}: This resistor sets the on-time, and (by default) the switching frequency. The switching frequency must be less than 1.6 MHz to ensure the minimum forced off-time does not interfere with the circuit's proper operation. The R_{ON} resistor is calculated from the following equation, using the minimum input voltage.

$$R_{ON} = \frac{V_{OUT} \times (V_{IN(min)} - 1.5V)}{F_S \times 1.13 \times 10^{-10} \times V_{IN(min)}} - 1.4 \text{ k}\Omega = 43.5 \text{ k}\Omega \quad (9)$$

Check that this value resistor does not set an on-time less than 120 ns at maximum V_{IN} .

A standard value 43.2 k Ω resistor is used, resulting in a nominal frequency of 806 kHz. The minimum on-time is \approx 231 ns at $V_{in} = 40V$, and the maximum on-time is \approx 875 ns at $V_{in} = 8V$. Alternately, R_{ON} can be determined using [Equation 5](#) if a specific on-time is required.

L1: The main parameter affected by the inductor is the inductor current ripple amplitude (I_{OR}). The minimum load current is used to determine the maximum allowable ripple in order to maintain continuous conduction mode, where the lower peak does not reach 0 mA. This is not a requirement of the LM34919, but serves as a guideline for selecting L1. For this case the maximum ripple current is:

$$I_{OR(MAX)} = 2 \times I_{OUT(min)} = 400 \text{ mA} \quad (10)$$

If the minimum load current is zero, use 20% of $I_{OUT(max)}$ for $I_{OUT(min)}$ in Equation 10. The ripple calculated in Equation 10 is then used in the following equation:

$$L1 = \frac{V_{OUT} \times (V_{IN(max)} - V_{OUT})}{I_{OR(max)} \times f_{SW} \times V_{IN(max)}} = 13.6 \mu\text{H} \quad (11)$$

A standard value 15 μH inductor is selected. The maximum ripple amplitude, which occurs at maximum V_{IN} , calculates to 362 mA p-p, and the peak current is 781 mA at maximum load current. Ensure the selected inductor is rated for this peak current.

C2 and R3: Since the LM34919 requires a minimum of 25 mVpp ripple at the FB pin for proper operation, the required ripple at V_{OUT} is increased by R1 and R2. This necessary ripple is created by the inductor ripple current flowing through R3, and to a lesser extent by C2 and its ESR. The minimum inductor ripple current is calculated using Equation 11, rearranged to solve for I_{OR} at minimum V_{IN} .

$$I_{OR(min)} = \frac{V_{OUT} \times (V_{IN(min)} - V_{OUT})}{L1 \times f_{SW} \times V_{IN(min)}} = 155 \text{ mA p-p} \quad (12)$$

The minimum value for R3 is equal to:

$$R3_{(min)} = \frac{25 \text{ mV} \times (R1 + R2)}{R2 \times I_{OR(min)}} = 0.32 \Omega \quad (13)$$

A standard value 0.39 Ω resistor is used for R3 to allow for tolerances. C2 should generally be no smaller than 3.3 μF , although that is dependent on the frequency and the desired output characteristics. C2 should be a low ESR good quality ceramic capacitor. Experimentation is usually necessary to determine the minimum value for C2, as the nature of the load may require a larger value. A load which creates significant transients requires a larger value for C2 than a non-varying load.

C1 and C5: C1's purpose is to supply most of the switch current during the on-time, and limit the voltage ripple at V_{IN} , on the assumption that the voltage source feeding V_{IN} has an output impedance greater than zero.

At maximum load current, when the buck switch turns on, the current into V_{IN} suddenly increases to the lower peak of the inductor's ripple current, ramps up to the upper peak, then drops to zero at turn-off. The average current during the on-time is the load current. For a worst case calculation, C1 must supply this average load current during the maximum on-time, without letting the voltage at V_{IN} drop below $\approx 7.5\text{V}$. The minimum value for C1 is calculated from:

$$C1 = \frac{I_{OUT(max)} \times t_{ON}}{\Delta V} = 1 \mu\text{F} \quad (14)$$

where t_{ON} is the maximum on-time, and ΔV is the allowable ripple voltage (0.5V at $V_{IN} = 8\text{V}$). C5's purpose is to minimize transients and ringing due to long lead inductance leading to the V_{IN} pin. A low ESR, 0.1 μF ceramic chip capacitor must be located close to the V_{IN} and RTN pins.

C3: The capacitor at the VCC pin provides noise filtering and stability for the VCC regulator. C3 should be no smaller than 0.1 μF , and should be a good quality, low ESR, ceramic capacitor. C3's value, and the V_{CC} current limit, determine a portion of the turn-on-time (t_1 in Figure 11).

C4: The recommended value for C4 is 0.022 μF . A high quality ceramic capacitor with low ESR is recommended as C4 supplies a surge current to charge the buck switch gate at each turn-on. A low ESR also helps ensure a complete recharge during each off-time.

C6: The capacitor at the SS pin determines the softstart time, i.e. the time for the output voltage, to reach its final value (t_2 in Figure 11). The capacitor value is determined from the following:

$$C6 = \frac{t_2 \times 10.5 \mu\text{A}}{2.5\text{V}} = 0.021 \mu\text{F} \quad (15)$$

D1: A Schottky diode is recommended. Ultra-fast recovery diodes are not recommended as the high speed transitions at the SW pin may inadvertently affect the IC's operation through external or internal EMI. The diode should be rated for the maximum input voltage, the maximum load current, and the peak current which occurs when the current limit and maximum ripple current are reached simultaneously. The diode's average power dissipation is calculated from:

$$P_{D1} = V_F \times I_{OUT} \times (1-D) \quad (16)$$

where V_F is the diode's forward voltage drop, and D is the on-time duty cycle.

FINAL CIRCUIT

The final circuit is shown in Figure 15, and its performance is shown in Figure 16 and Figure 17. Current limit measured approximately 650 mA at 8V, and 740 mA at 40V.

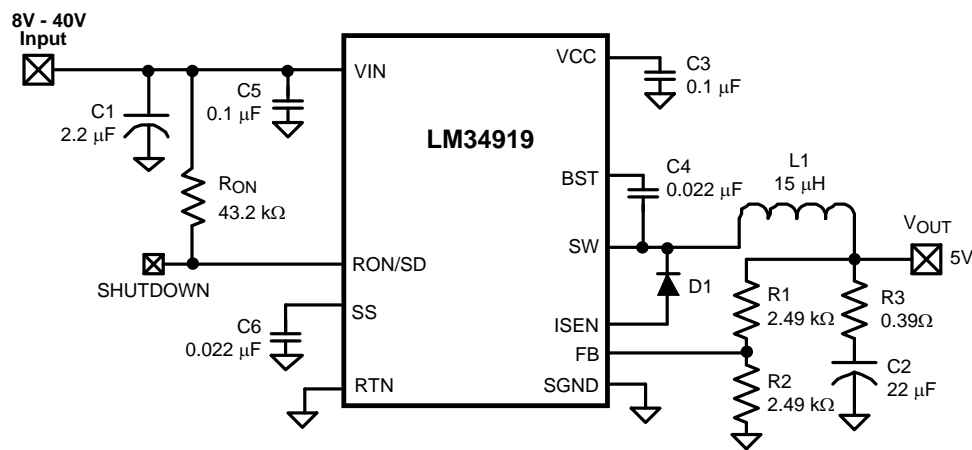

Figure 15. Example Circuit

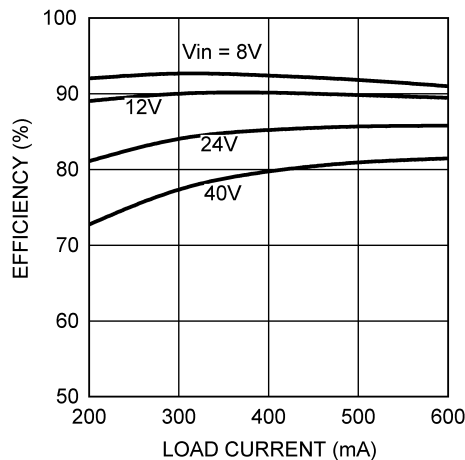

Figure 16. Efficiency vs. Load Current and V_{IN} (Circuit of Figure 15)

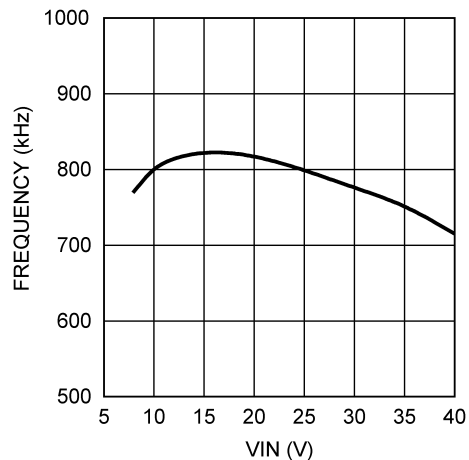

Figure 17. Frequency vs. V_{IN} (Circuit of Figure 15)

LOW OUTPUT RIPPLE CONFIGURATIONS

For applications where lower ripple at V_{OUT} is required, the following options can be used to reduce or nearly eliminate the ripple.

a) Reduced ripple configuration: In Figure 18, Cff is added across R1 to AC-couple the ripple at V_{OUT} directly to the FB pin. This allows the ripple at V_{OUT} to be reduced to a minimum of 25 mVpp by reducing R3, since the ripple at V_{OUT} is not attenuated by the feedback resistors. The minimum value for Cff is determined from:

$$C_{ff} = \frac{t_{ON(max)}}{(R1//R2)} \quad (17)$$

where t_{ON(max)} is the maximum on-time, which occurs at V_{IN(min)}. The next larger standard value capacitor should be used for Cff. R1 and R2 should each be towards the upper end of the 2 kΩ to 10 kΩ range.

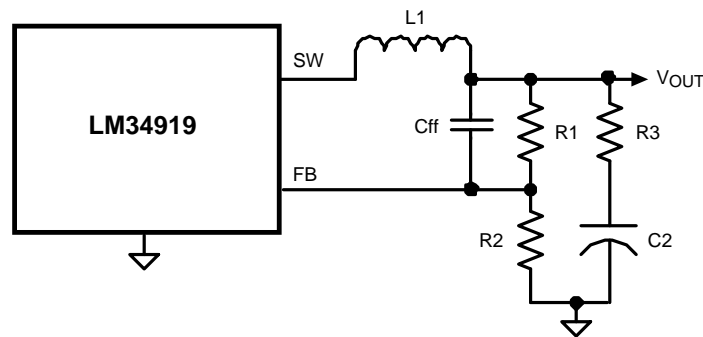

Figure 18. Reduced Ripple Configuration

b) Minimum ripple configuration: The circuit of Figure 19 provides minimum ripple at V_{OUT}, determined primarily by C2's characteristics and the inductor's ripple current since R3 is removed. RA and CA are chosen to generate a sawtooth waveform at their junction, and that voltage is AC-coupled to the FB pin via CB. To determine the values for RA, CA and CB, use the following procedure:

$$\text{Calculate } V_A = V_{OUT} - (V_{SW} \times (1 - (V_{OUT}/V_{IN(min)}))) \quad (18)$$

where V_{SW} is the absolute value of the voltage at the SW pin during the off-time (typically 1V). V_A is the DC voltage at the RA/CA junction, and is used in the next equation.

$$RA \times CA = \frac{(V_{IN(min)} - V_A) \times t_{ON}}{\Delta V} \quad (19)$$

where t_{ON} is the maximum on-time (at minimum input voltage), and ΔV is the desired ripple amplitude at the RA/CA junction, typically 100 mV. RA and CA are then chosen from standard value components to satisfy the above product. Typically CA is 3000 pF to 5000 pF, and RA is 10 kΩ to 300 kΩ. CB is then chosen large compared to CA, typically 0.1 μF. R1 and R2 should each be towards the upper end of the 2 kΩ to 10 kΩ range.

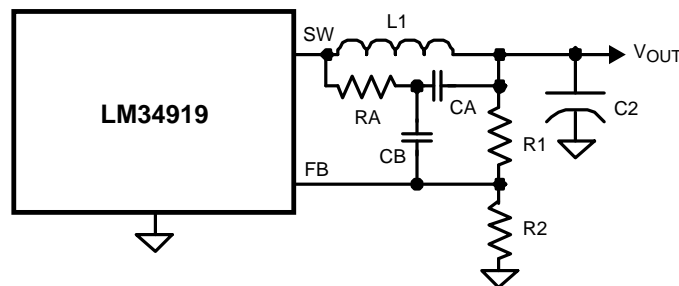

Figure 19. Minimum Output Ripple Using Ripple Injection

c) Alternate minimum ripple configuration: The circuit in Figure 20 is the same as that in Figure 15, except the output voltage is taken from the junction of R3 and C2. The ripple at V_{OUT} is determined by the inductor's ripple current and C2's characteristics. However, R3 slightly degrades the load regulation. This circuit may be suitable if the load current is fairly constant.

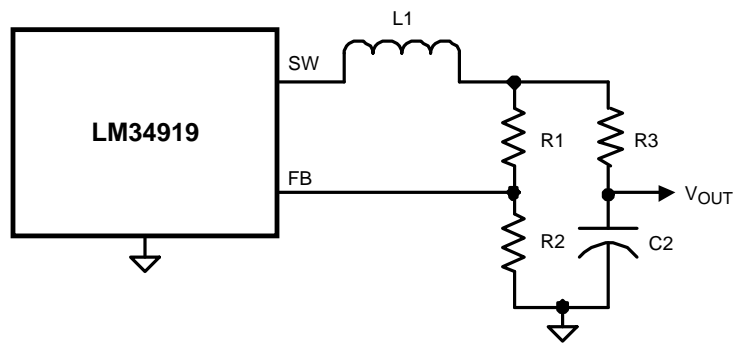

Figure 20. Alternate Minimum Output Ripple Configuration

Minimum Load Current

The LM34919 requires a minimum load current of 1 mA. If the load current falls below that level, the bootstrap capacitor (C4) may discharge during the long off-time, and the circuit will either shutdown, or cycle on and off at a low frequency. If the load current is expected to drop below 1 mA in the application, R1 and R2 should be chosen low enough in value so they provide the minimum required current at nominal V_{OUT} .

PC BOARD LAYOUT

Refer to application note AN-1112 for PC board guidelines for the DSBGA package.

The LM34919 regulation, over-voltage, and current limit comparators are very fast, and respond to short duration noise pulses. Layout considerations are therefore critical for optimum performance. The layout must be as neat and compact as possible, and all of the components must be as close as possible to their associated pins. The two major current loops have currents which switch very fast, and so the loops should be as small as possible to minimize conducted and radiated EMI. The first loop is that formed by C1, through the VIN to SW pins, L1, C2, and back to C1. The second current loop is formed by D1, L1, C2 and the SGND and ISEN pins.

The power dissipation within the LM34919 can be approximated by determining the total conversion loss ($P_{IN} - P_{OUT}$), and then subtracting the power losses in the free-wheeling diode and the inductor. The power loss in the diode is approximately:

$$P_{D1} = I_{out} \times V_F \times (1-D) \quad (20)$$

where I_{out} is the load current, V_F is the diode's forward voltage drop, and D is the on-time duty cycle. The power loss in the inductor is approximately:

$$P_{L1} = I_{out}^2 \times R_L \times 1.1 \quad (21)$$

where R_L is the inductor's DC resistance, and the 1.1 factor is an approximation for the AC losses. If it is expected that the internal dissipation of the LM34919 will produce excessive junction temperatures during normal operation, good use of the PC board's ground plane can help to dissipate heat. Additionally the use of wide PC board traces, where possible, can help conduct heat away from the IC. Judicious positioning of the PC board within the end product, along with the use of any available air flow (forced or natural convection) can help reduce the junction temperatures.

REVISION HISTORY

Changes from Revision D (February 2013) to Revision E	Page
• Changed layout of National Data Sheet to TI format	15

PACKAGING INFORMATION

Orderable Device	Status (1)	Package Type	Package Drawing	Pins	Package Qty	Eco Plan (2)	Lead/Ball Finish	MSL Peak Temp (3)	Op Temp (°C)	Top-Side Markings (4)	Samples
LM34919TL/NOPB	ACTIVE	DSBGA	YPA	10	250	Green (RoHS & no Sb/Br)	SNAGCU	Level-1-260C-UNLIM	-40 to 125	SRYB	Samples
LM34919TLX/NOPB	ACTIVE	DSBGA	YPA	10	3000	Green (RoHS & no Sb/Br)	SNAGCU	Level-1-260C-UNLIM	-40 to 125	SRYB	Samples

(1) The marketing status values are defined as follows:

ACTIVE: Product device recommended for new designs.

LIFEBUY: TI has announced that the device will be discontinued, and a lifetime-buy period is in effect.

NRND: Not recommended for new designs. Device is in production to support existing customers, but TI does not recommend using this part in a new design.

PREVIEW: Device has been announced but is not in production. Samples may or may not be available.

OBSOLETE: TI has discontinued the production of the device.

(2) Eco Plan - The planned eco-friendly classification: Pb-Free (RoHS), Pb-Free (RoHS Exempt), or Green (RoHS & no Sb/Br) - please check <http://www.ti.com/productcontent> for the latest availability information and additional product content details.

TBD: The Pb-Free/Green conversion plan has not been defined.

Pb-Free (RoHS): TI's terms "Lead-Free" or "Pb-Free" mean semiconductor products that are compatible with the current RoHS requirements for all 6 substances, including the requirement that lead not exceed 0.1% by weight in homogeneous materials. Where designed to be soldered at high temperatures, TI Pb-Free products are suitable for use in specified lead-free processes.

Pb-Free (RoHS Exempt): This component has a RoHS exemption for either 1) lead-based flip-chip solder bumps used between the die and package, or 2) lead-based die adhesive used between the die and leadframe. The component is otherwise considered Pb-Free (RoHS compatible) as defined above.

Green (RoHS & no Sb/Br): TI defines "Green" to mean Pb-Free (RoHS compatible), and free of Bromine (Br) and Antimony (Sb) based flame retardants (Br or Sb do not exceed 0.1% by weight in homogeneous material)

(3) MSL, Peak Temp. -- The Moisture Sensitivity Level rating according to the JEDEC industry standard classifications, and peak solder temperature.

(4) Multiple Top-Side Markings will be inside parentheses. Only one Top-Side Marking contained in parentheses and separated by a "~" will appear on a device. If a line is indented then it is a continuation of the previous line and the two combined represent the entire Top-Side Marking for that device.

Important Information and Disclaimer: The information provided on this page represents TI's knowledge and belief as of the date that it is provided. TI bases its knowledge and belief on information provided by third parties, and makes no representation or warranty as to the accuracy of such information. Efforts are underway to better integrate information from third parties. TI has taken and continues to take reasonable steps to provide representative and accurate information but may not have conducted destructive testing or chemical analysis on incoming materials and chemicals. TI and TI suppliers consider certain information to be proprietary, and thus CAS numbers and other limited information may not be available for release.

In no event shall TI's liability arising out of such information exceed the total purchase price of the TI part(s) at issue in this document sold by TI to Customer on an annual basis.

TAPE AND REEL INFORMATION



QUADRANT ASSIGNMENTS FOR PIN 1 ORIENTATION IN TAPE



*All dimensions are nominal

Device	Package Type	Package Drawing	Pins	SPQ	Reel Diameter (mm)	Reel Width W1 (mm)	A0 (mm)	B0 (mm)	K0 (mm)	P1 (mm)	W (mm)	Pin1 Quadrant
LM34919TL/NOPB	DSBGA	YPA	10	250	178.0	8.4	1.68	2.13	0.76	4.0	8.0	Q1
LM34919TLX/NOPB	DSBGA	YPA	10	3000	178.0	8.4	1.68	2.13	0.76	4.0	8.0	Q1

TAPE AND REEL BOX DIMENSIONS

*All dimensions are nominal

Device	Package Type	Package Drawing	Pins	SPQ	Length (mm)	Width (mm)	Height (mm)
LM34919TL/NOPB	DSBGA	YPA	10	250	210.0	185.0	35.0
LM34919TLX/NOPB	DSBGA	YPA	10	3000	210.0	185.0	35.0

YPA0010

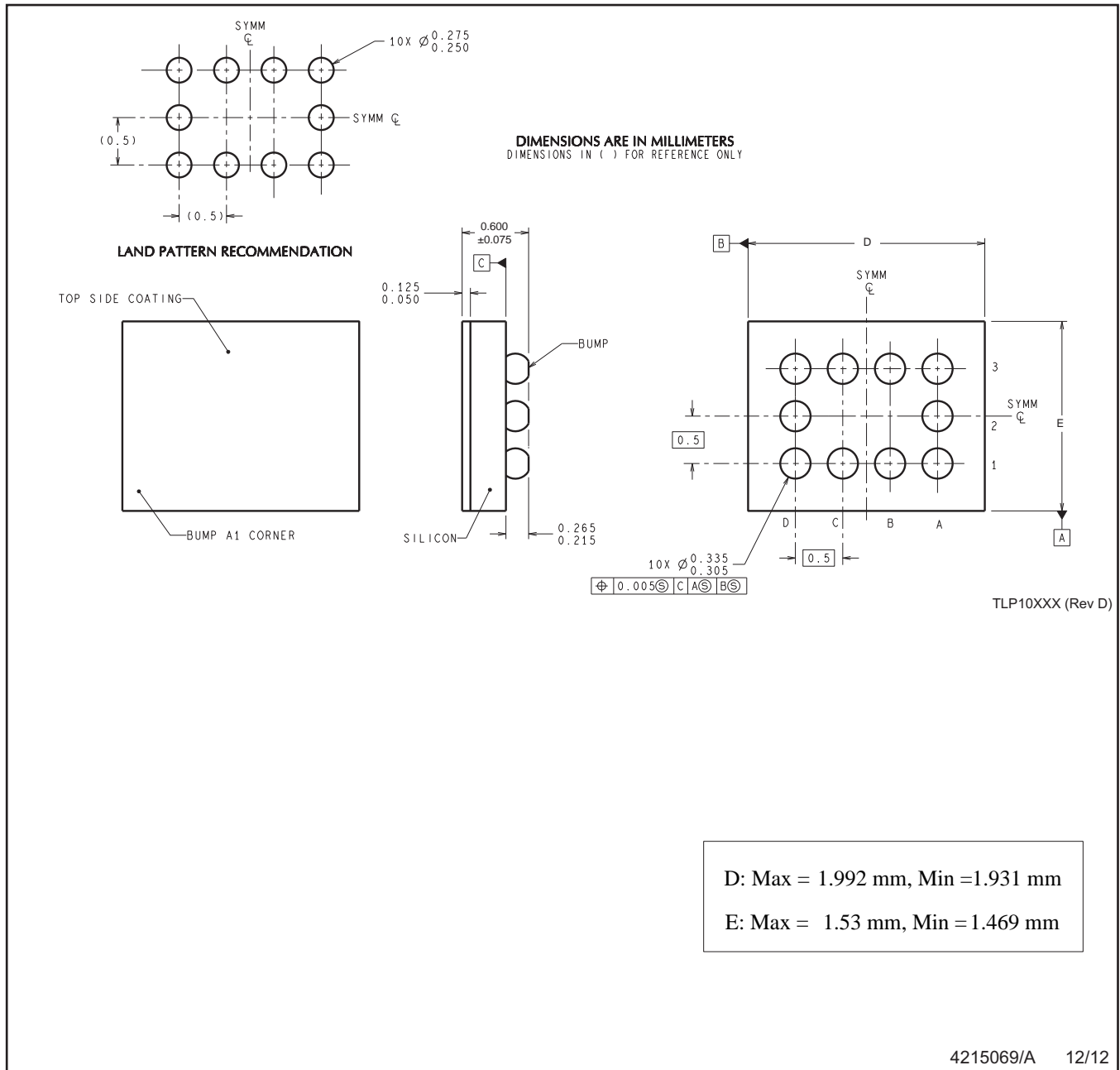

NOTES: A. All linear dimensions are in millimeters. Dimensioning and tolerancing per ASME Y14.5M-1994.
B. This drawing is subject to change without notice.

IMPORTANT NOTICE

Texas Instruments Incorporated (TI) reserves the right to make corrections, enhancements, improvements and other changes to its semiconductor products and services per JESD46, latest issue, and to discontinue any product or service per JESD48, latest issue. Buyers should obtain the latest relevant information before placing orders and should verify that such information is current and complete.

TI's published terms of sale for semiconductor products (<http://www.ti.com/sc/docs/stdterms.htm>) apply to the sale of packaged integrated circuit products that TI has qualified and released to market. Additional terms may apply to the use or sale of other types of TI products and services.

Reproduction of significant portions of TI information in TI data sheets is permissible only if reproduction is without alteration and is accompanied by all associated warranties, conditions, limitations, and notices. TI is not responsible or liable for such reproduced documentation. Information of third parties may be subject to additional restrictions. Resale of TI products or services with statements different from or beyond the parameters stated by TI for that product or service voids all express and any implied warranties for the associated TI product or service and is an unfair and deceptive business practice. TI is not responsible or liable for any such statements.

Buyers and others who are developing systems that incorporate TI products (collectively, "Designers") understand and agree that Designers remain responsible for using their independent analysis, evaluation and judgment in designing their applications and that Designers have full and exclusive responsibility to assure the safety of Designers' applications and compliance of their applications (and of all TI products used in or for Designers' applications) with all applicable regulations, laws and other applicable requirements. Designer represents that, with respect to their applications, Designer has all the necessary expertise to create and implement safeguards that (1) anticipate dangerous consequences of failures, (2) monitor failures and their consequences, and (3) lessen the likelihood of failures that might cause harm and take appropriate actions. Designer agrees that prior to using or distributing any applications that include TI products, Designer will thoroughly test such applications and the functionality of such TI products as used in such applications.

TI's provision of technical, application or other design advice, quality characterization, reliability data or other services or information, including, but not limited to, reference designs and materials relating to evaluation modules, (collectively, "TI Resources") are intended to assist designers who are developing applications that incorporate TI products; by downloading, accessing or using TI Resources in any way, Designer (individually or, if Designer is acting on behalf of a company, Designer's company) agrees to use any particular TI Resource solely for this purpose and subject to the terms of this Notice.

TI's provision of TI Resources does not expand or otherwise alter TI's applicable published warranties or warranty disclaimers for TI products, and no additional obligations or liabilities arise from TI providing such TI Resources. TI reserves the right to make corrections, enhancements, improvements and other changes to its TI Resources. TI has not conducted any testing other than that specifically described in the published documentation for a particular TI Resource.

Designer is authorized to use, copy and modify any individual TI Resource only in connection with the development of applications that include the TI product(s) identified in such TI Resource. NO OTHER LICENSE, EXPRESS OR IMPLIED, BY ESTOPPEL OR OTHERWISE TO ANY OTHER TI INTELLECTUAL PROPERTY RIGHT, AND NO LICENSE TO ANY TECHNOLOGY OR INTELLECTUAL PROPERTY RIGHT OF TI OR ANY THIRD PARTY IS GRANTED HEREIN, including but not limited to any patent right, copyright, mask work right, or other intellectual property right relating to any combination, machine, or process in which TI products or services are used. Information regarding or referencing third-party products or services does not constitute a license to use such products or services, or a warranty or endorsement thereof. Use of TI Resources may require a license from a third party under the patents or other intellectual property of the third party, or a license from TI under the patents or other intellectual property of TI.

TI RESOURCES ARE PROVIDED "AS IS" AND WITH ALL FAULTS. TI DISCLAIMS ALL OTHER WARRANTIES OR REPRESENTATIONS, EXPRESS OR IMPLIED, REGARDING RESOURCES OR USE THEREOF, INCLUDING BUT NOT LIMITED TO ACCURACY OR COMPLETENESS, TITLE, ANY EPIDEMIC FAILURE WARRANTY AND ANY IMPLIED WARRANTIES OF MERCHANTABILITY, FITNESS FOR A PARTICULAR PURPOSE, AND NON-INFRINGEMENT OF ANY THIRD PARTY INTELLECTUAL PROPERTY RIGHTS. TI SHALL NOT BE LIABLE FOR AND SHALL NOT DEFEND OR INDEMNIFY DESIGNER AGAINST ANY CLAIM, INCLUDING BUT NOT LIMITED TO ANY INFRINGEMENT CLAIM THAT RELATES TO OR IS BASED ON ANY COMBINATION OF PRODUCTS EVEN IF DESCRIBED IN TI RESOURCES OR OTHERWISE. IN NO EVENT SHALL TI BE LIABLE FOR ANY ACTUAL, DIRECT, SPECIAL, COLLATERAL, INDIRECT, PUNITIVE, INCIDENTAL, CONSEQUENTIAL OR EXEMPLARY DAMAGES IN CONNECTION WITH OR ARISING OUT OF TI RESOURCES OR USE THEREOF, AND REGARDLESS OF WHETHER TI HAS BEEN ADVISED OF THE POSSIBILITY OF SUCH DAMAGES.

Unless TI has explicitly designated an individual product as meeting the requirements of a particular industry standard (e.g., ISO/TS 16949 and ISO 26262), TI is not responsible for any failure to meet such industry standard requirements.

Where TI specifically promotes products as facilitating functional safety or as compliant with industry functional safety standards, such products are intended to help enable customers to design and create their own applications that meet applicable functional safety standards and requirements. Using products in an application does not by itself establish any safety features in the application. Designers must ensure compliance with safety-related requirements and standards applicable to their applications. Designer may not use any TI products in life-critical medical equipment unless authorized officers of the parties have executed a special contract specifically governing such use. Life-critical medical equipment is medical equipment where failure of such equipment would cause serious bodily injury or death (e.g., life support, pacemakers, defibrillators, heart pumps, neurostimulators, and implantables). Such equipment includes, without limitation, all medical devices identified by the U.S. Food and Drug Administration as Class III devices and equivalent classifications outside the U.S.

TI may expressly designate certain products as completing a particular qualification (e.g., Q100, Military Grade, or Enhanced Product). Designers agree that it has the necessary expertise to select the product with the appropriate qualification designation for their applications and that proper product selection is at Designers' own risk. Designers are solely responsible for compliance with all legal and regulatory requirements in connection with such selection.

Designer will fully indemnify TI and its representatives against any damages, costs, losses, and/or liabilities arising out of Designer's non-compliance with the terms and provisions of this Notice.

Looking for pricing, stock, or lifecycle information?

Click below to explore more details on WIN SOURCE:

 [View LM34919TLX/NOPB on WIN SOURCE](#)

 [Texas Instruments](#) Information

Optimize Your Supply Chain with WIN SOURCE Solutions

-  Global Sourcing Solution
-  Obsolete Management
-  Cost Control Management
-  Shortage Management
-  Alternative Solution
-  Excess Inventory Management