



**THE DATASHEET OF  
LM4121IM5-1.2/NOPB**



## LM4121 Precision Micropower Low Dropout Voltage Reference

Check for Samples: [LM4121](#)

### FEATURES (LM4121-1.2)

- Small SOT23-5 Package
- Low Voltage Operation
- High Output Voltage Accuracy: 0.2%
- Source and Sink Current Output:  $\pm 5$  mA
- Supply current: 160  $\mu$ A Typ.
- Low Temperature Coefficient: 50 ppm/ $^{\circ}$ C
- Enable Pin
- Output Voltages: 1.25V and Adjustable
- Industrial Temperature Range:  $-40^{\circ}$ C to  $+85^{\circ}$ C
- (For Extended Temperature Range,  $-40^{\circ}$ C to  $125^{\circ}$ C, Contact Texas Instruments)

### APPLICATIONS

- Portable, Battery Powered Equipment
- Instrumentation and Process Control
- Automotive & Industrial
- Test Equipment
- Data Acquisition Systems
- Precision Regulators
- Battery Chargers
- Base Stations
- Communications
- Medical Equipment

### Block Diagram

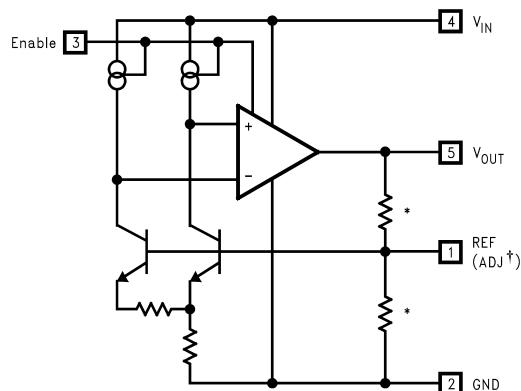

\* Resistors are removed on the LM4121-ADJ  
†LM4121-ADJ only

**Figure 1. LM4121-1.2 Block Diagram**

Please be aware that an important notice concerning availability, standard warranty, and use in critical applications of Texas Instruments semiconductor products and disclaimers thereto appears at the end of this data sheet.

All trademarks are the property of their respective owners.

### DESCRIPTION

The LM4121 is a precision bandgap voltage reference available in a fixed 1.25V and adjustable version with up to 5 mA current source and sink capability.

This series reference operates with input voltages as low as 1.8V and up to 12V consuming 160  $\mu$ A (Typ.) supply current. In power down mode, device current drops to less than 2  $\mu$ A.

The LM4121 comes in two grades A and Standard. The best grade devices (A) have an initial accuracy of 0.2%, while the standard have an initial accuracy of 0.5%, both with a tempco of 50ppm/ $^{\circ}$ C ensured from  $-40^{\circ}$ C to  $+125^{\circ}$ C.

The very low operating voltage, low supply current and power-down capability of the LM4121 makes this product an ideal choice for battery powered and portable applications.

The device performance is ensured over the industrial temperature range ( $-40^{\circ}$ C to  $+85^{\circ}$ C), while certain specs are ensured over the extended temperature range ( $-40^{\circ}$ C to  $+125^{\circ}$ C). Please contact Texas Instruments for full specifications over the extended temperature range. The LM4121 is available in a standard 5-pin SOT-23 package.

## Connection Diagrams

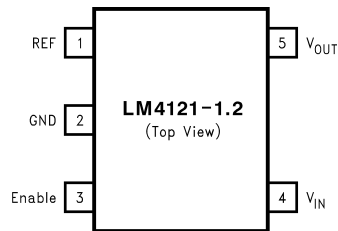

Figure 2. SOT23-5 Surface Mount Package

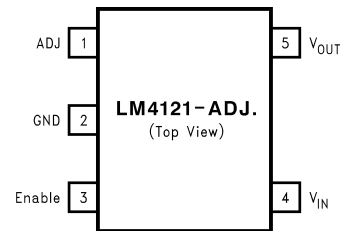

Figure 3. SOT23-5 Surface Mount Package

Table 1. SOT-23 Package Marking Information<sup>(1)</sup>

Field Information
First Field:
R = Reference
Second and third Field:
19 = 1.250V Voltage Option
20 = Adjustable
Fourth Field:
A-B = Initial Reference Voltage Tolerance
A = $\pm 0.2\%$
B = $\pm 0.5\%$

(1) Only four fields of marking are possible on the SOT-23's small surface. This table gives the meaning of the four fields.



These devices have limited built-in ESD protection. The leads should be shorted together or the device placed in conductive foam during storage or handling to prevent electrostatic damage to the MOS gates.

## Absolute Maximum Ratings<sup>(1)(2)</sup>

Maximum Voltage on input or enable pins	-0.3V to 14V
Output Short-Circuit Duration	Indefinite
Power Dissipation ( $T_A = 25^\circ\text{C}$ ) <sup>(3)</sup> :	
DBV0005B package - $\theta_{JA}$	280°C/W
Power Dissipation	350 mW
ESD Susceptibility <sup>(4)</sup>	
Human Body Model	2 kV
Machine Model	200V
Lead Temperature:	
Soldering, (10 sec.)	+260°C
Vapor Phase (60 sec.)	+215°C
Infrared (15 sec.)	+220°C

- (1) "Absolute Maximum Ratings" indicate limits beyond which damage to the device may occur. Operating Ratings indicate conditions for which the device is intended to be functional, but do not ensure specific performance limits. For ensured specifications and test conditions, see [Electrical Characteristics - LM4121-1.250V](#) and [Electrical Characteristics - LM4121-ADJ](#) tables. The ensured specifications apply only for the test conditions listed. Some performance characteristics may degrade when the device is not operated under the listed test conditions.
- (2) If Military/Aerospace specified devices are required, please contact the Texas Instruments Sales Office/ Distributors for availability and specifications.
- (3) Without PCB copper enhancements. The maximum power dissipation must be de-rated at elevated temperatures and is limited by  $T_{JMAX}$  (maximum junction temperature),  $\theta_{J-A}$  (junction to ambient thermal resistance) and  $T_A$  (ambient temperature). The maximum power dissipation at any temperature is:  $PD_{MAX} = (T_{JMAX} - T_A) / \theta_{J-A}$  up to the value listed in the [Absolute Maximum Ratings](#).
- (4) The human body model is a 100 pF capacitor discharged through a 1.5 kΩ resistor into each pin. The machine model is a 200 pF capacitor discharged directly into each pin.

**Operating Range** <sup>(1)</sup>

Storage Temperature Range	-65°C to +150°C
Ambient Temperature Range	-40°C to +85°C
Junction Temperature Range	-40°C to +125°C

- (1) "Absolute Maximum Ratings" indicate limits beyond which damage to the device may occur. Operating Ratings indicate conditions for which the device is intended to be functional, but do not ensure specific performance limits. For ensured specifications and test conditions, see [Electrical Characteristics - LM4121-1.250V](#) and [Electrical Characteristics - LM4121-ADJ](#) tables. The ensured specifications apply only for the test conditions listed. Some performance characteristics may degrade when the device is not operated under the listed test conditions.

**Electrical Characteristics  
LM4121-1.250V**

Unless otherwise specified  $V_{IN} = 3.3V$ ,  $I_{LOAD} = 0$ ,  $C_{OUT} = 0.01\mu F$ ,  $T_A = T_j = 25^\circ C$ . Limits with standard typeface are for  $T_j = 25^\circ C$ , and limits in **boldface type** apply over the  $-40^\circ C \leq T_A \leq +85^\circ C$  temperature range.

Symbol	Parameter	Conditions	Min <sup>(1)</sup>	Typ <sup>(2)</sup>	Max <sup>(1)</sup>	Units
$V_{OUT}$	Output Voltage Initial Accuracy LM4121A-1.250			1.250	±0.2	%
	LM4121-1.250				±0.5	
$TCV_{OUT}/^\circ C$	Temperature Coefficient	$-40^\circ C \leq T_A \leq +125^\circ C$		14	50	ppm/ $^\circ C$
$\Delta V_{OUT}/\Delta V_{IN}$	Line Regulation	$1.8V \leq V_{IN} \leq 12V$		0.0007	0.009 <b>0.012</b>	%/V
$\Delta V_{OUT}/\Delta I_{LOAD}$	Load Regulation	$0 mA \leq I_{LOAD} \leq 1 mA$		0.03	0.08 <b>0.17</b>	%mA
		$1 mA \leq I_{LOAD} \leq 5 mA$		0.01	0.04 <b>0.1</b>	
		$-1 mA \leq I_{LOAD} \leq 0 mA$		0.04	0.12	
		$-5 mA \leq I_{LOAD} \leq -1 mA$		0.01		
Min- $V_{IN}$	Minimum Operating Voltage	$I_{LOAD} = 5mA$		1.5	<b>1.8</b>	V
$V_N$	Output Noise Voltage	0.1 Hz to 10 Hz		20		$\mu V_{PP}$
		10 Hz to 10 kHz		30		$\mu V_{RMS}$
$I_S$	Supply Current			160	250 <b>275</b>	$\mu A$
$I_{SS}$	Power-down Supply Current	$V_{IN} = 12V$ Enable = 0.4V <b>Enable = 0.2V</b>			1 <b>2</b>	$\mu A$
$V_H$	Logic High Input Voltage		<b>1.6</b>	1.5		V
$V_L$	Logic Low Input Voltage			0.4	<b>0.2</b>	V
$I_H$	Logic High Input Current			7	<b>15</b>	$\mu A$
$I_L$	Logic Low Input Current			0.1		$\mu A$
$I_{SC}$	Short Circuit Current	$V_{IN} = 3.3V, V_{OUT} = 0$		15		mA
			<b>6</b>		<b>30</b>	
		$V_{IN} = 12V, V_{OUT} = 0$		17		
			<b>6</b>		<b>30</b>	
Hyst	Thermal Hysteresis <sup>(3)</sup>	$-40^\circ C \leq T_A \leq 125^\circ C$		0.5		mV/V

- (1) Limits are 100% production tested at 25°C. Limits over the operating temperature range are ensured through correlation using Statistical Quality Control (SQC) methods. The limits are used to calculate TI's Averaging Outgoing Quality Level (AOQL).

- (2) Typical numbers are at 25°C and represent the most likely parametric norm.

- (3) Thermal hysteresis is defined as the change in +25°C output voltage before and after exposing the device to temperature extremes.

## Electrical Characteristics LM4121-1.250V (continued)

Unless otherwise specified  $V_{IN} = 3.3V$ ,  $I_{LOAD} = 0$ ,  $C_{OUT} = 0.01\mu F$ ,  $T_A = T_j = 25^\circ C$ . Limits with standard typeface are for  $T_j = 25^\circ C$ , and limits in **boldface type** apply over the  $-40^\circ C \leq T_A \leq +85^\circ C$  temperature range.

Symbol	Parameter	Conditions	Min <sup>(1)</sup>	Typ <sup>(2)</sup>	Max <sup>(1)</sup>	Units
$\Delta V_{OUT}$	Long Term Stability (4)	1000 hrs. @ 25°C		100		ppm

(4) Long term stability is change in  $V_{REF}$  at 25°C measured continuously during 1000 hrs.

## Electrical Characteristics LM4121-ADJ

Unless otherwise specified  $V_{IN} = 3.3V$ ,  $V_{OUT} = V_{REF}$ ,  $I_{LOAD} = 0$ ,  $C_{OUT} = 0.01\mu F$ ,  $T_A = T_j = 25^\circ C$ . Limits with standard typeface are for  $T_j = 25^\circ C$ , and limits in **boldface type** apply over the  $-40^\circ C \leq T_A \leq +85^\circ C$  temperature range.

Symbol	Parameter	Conditions	Min <sup>(1)</sup>	Typ <sup>(2)</sup>	Max <sup>(1)</sup>	Units
$V_{OUT} = V_{REF}$	Output Voltage Initial Accuracy LM4121A-ADJ			1.216	$\pm 0.2$	%
	LM4121-ADJ				$\pm 0.5$	
$TCV_{REF}/^\circ C$	Temperature Coefficient	$-40^\circ C \leq T_A \leq +125^\circ C$		14	50	ppm/ $^\circ C$
$\Delta V_{REF}/\Delta V_{IN}$	Line Regulation	$1.8V \leq V_{IN} \leq 12V$		0.0007	0.009 <b>0.012</b>	%/V
$\Delta V_{OUT}/\Delta I_{LOAD}$	Load Regulation	$0 mA \leq I_{LOAD} \leq 1 mA$		0.03	0.08 <b>0.17</b>	%/ $mA$
		$1 mA \leq I_{LOAD} \leq 5 mA$		0.01	0.04 <b>0.1</b>	
		$-1 mA \leq I_{LOAD} \leq 0 mA$		0.04	0.12	
		$-5 mA \leq I_{LOAD} \leq -1 mA$		0.01		
Min- $V_{IN}$	Minimum Operating Voltage	$I_{LOAD} = 5 mA$		1.5	<b>1.8</b>	V
$V_N$	Output Noise Voltage (3)	0.1 Hz to 10 Hz		20		$\mu V_{PP}$
		10 Hz to 10 kHz		30		$\mu V_{RMS}$
$I_S$	Supply Current			160	250 <b>275</b>	$\mu A$
$I_{SS}$	Power-down Supply Current	$V_{IN} = 12V$ Enable = 0.4V <b>Enable = 0.2V</b>			1 <b>2</b>	$\mu A$
$I_{BIAS}$	Reference Pin Bias Current (4)		15	<b>40</b>		nA
$V_H$	Logic High Input Voltage		<b>1.6</b>	1.5		V
$V_L$	Logic Low Input Voltage			0.4	<b>0.2</b>	V
$I_H$	Logic High Input Current			7	<b>15</b>	$\mu A$
$I_L$	Logic Low Input Current			0.1		$\mu A$
$I_{SC}$	Short Circuit Current	$V_{OUT} = 0$		15		mA
		$V_{IN} = 12V, V_{OUT} = 0$	<b>6</b>		<b>30</b>	
			<b>6</b>	17	<b>30</b>	

- (1) Limits are 100% production tested at 25°C. Limits over the operating temperature range are ensured through correlation using Statistical Quality Control (SQC) methods. The limits are used to calculate TI's Averaging Outgoing Quality Level (AOQL).
- (2) Typical numbers are at 25°C and represent the most likely parametric norm.
- (3) Output noise for 1.25V option. Noise is proportional to  $V_{OUT}$ .
- (4) Bias Current flows out of the Adjust pin.

## Electrical Characteristics LM4121-ADJ (continued)

Unless otherwise specified  $V_{IN} = 3.3V$ ,  $V_{OUT} = V_{REF}$ ,  $I_{LOAD} = 0$ ,  $C_{OUT} = 0.01\mu F$ ,  $T_A = T_j = 25^\circ C$ . Limits with standard typeface are for  $T_j = 25^\circ C$ , and limits in **boldface type** apply over the  $-40^\circ C \leq T_A \leq +85^\circ C$  temperature range.

Symbol	Parameter	Conditions	Min <sup>(1)</sup>	Typ <sup>(2)</sup>	Max <sup>(1)</sup>	Units
Hyst	Thermal Hysteresis <sup>(5)</sup>	$-40^\circ C \leq T_A \leq 125^\circ C$		0.5		mV/V
$\Delta V_{OUT}$	Long Term Stability <sup>(6)</sup>	1000 hrs. @ $25^\circ C$		100		ppm

(5) Thermal hysteresis is defined as the change in  $+25^\circ C$  output voltage before and after exposing the device to temperature extremes.

(6) Long term stability is change in  $V_{REF}$  at  $25^\circ C$  measured continuously during 1000 hrs.

### LM4121- (All Options) Typical Operating Characteristics

Unless otherwise specified,  $V_{IN} = 3.3V$ ,  $V_{OUT} = 1.25V$ ,  $I_{LOAD} = 0$ ,  $C_{OUT} = 0.022\mu F$ ,  $T_A = 25^\circ C$  and  $V_{EN} = V_{IN}$ .

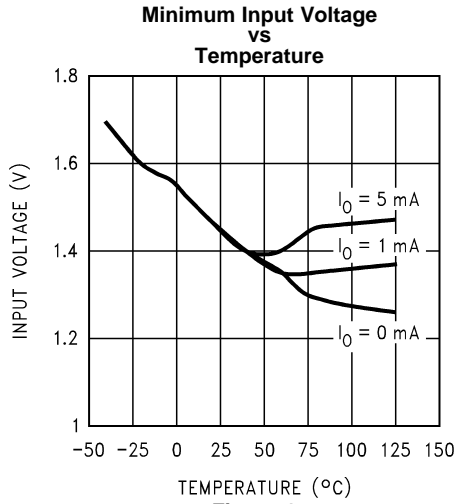

Figure 4.

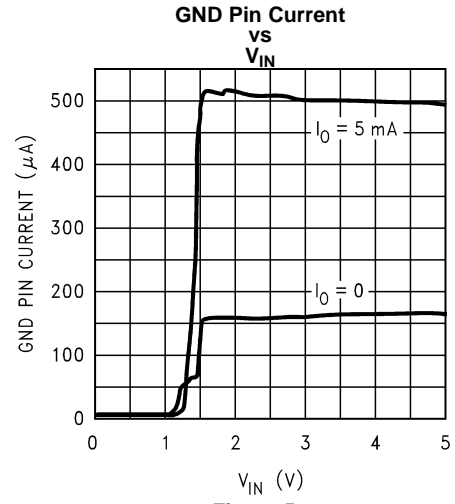

Figure 5.

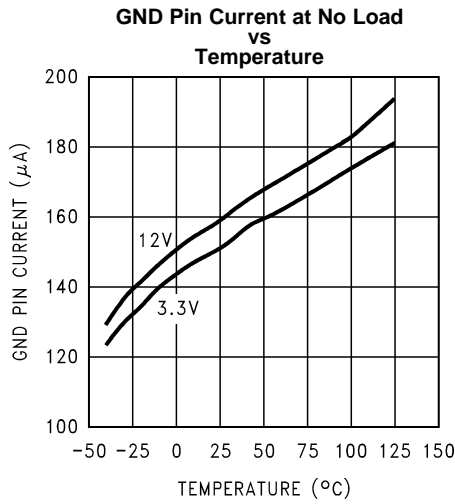

Figure 6.

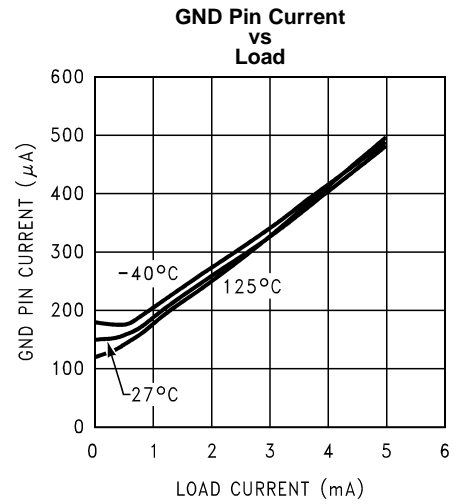

Figure 7.

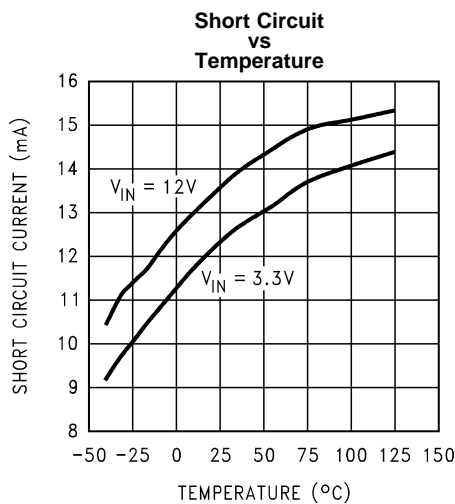

Figure 8.

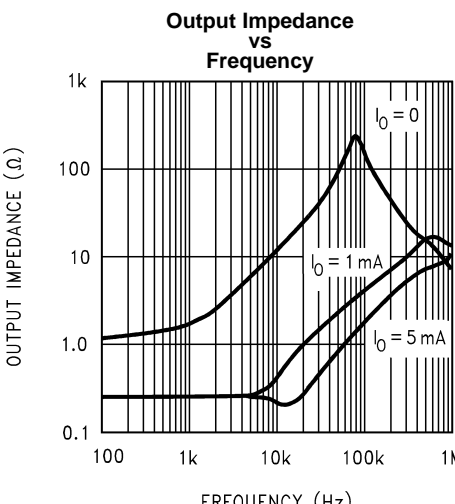

Figure 9.

**LM4121- (All Options) Typical Operating Characteristics (continued)**

Unless otherwise specified,  $V_{IN} = 3.3V$ ,  $V_{OUT} = 1.25V$ ,  $I_{LOAD} = 0$ ,  $C_{OUT} = 0.022\mu F$ ,  $T_A = 25^\circ C$  and  $V_{EN} = V_{IN}$ .

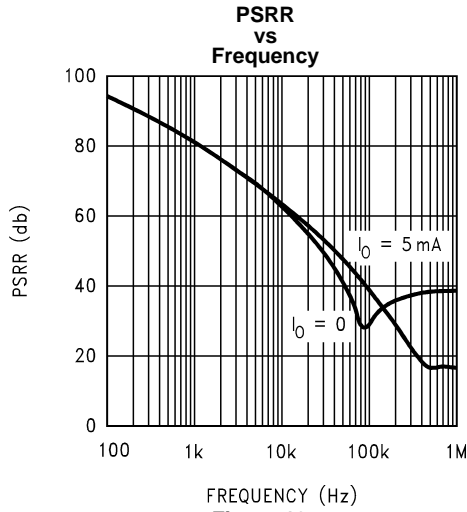

Figure 10.

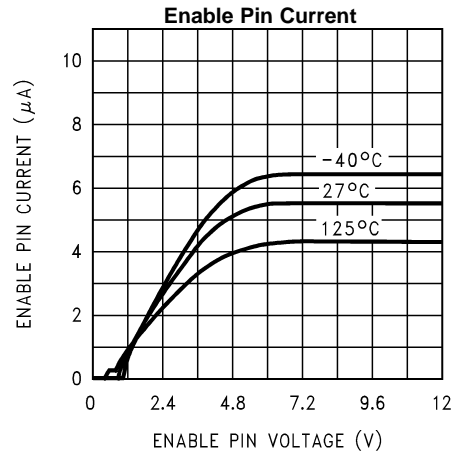

Figure 11.

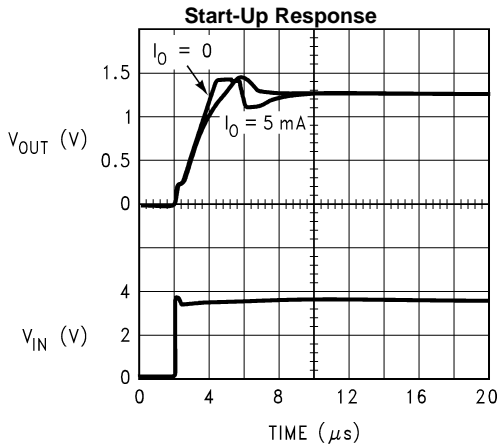

Figure 12.

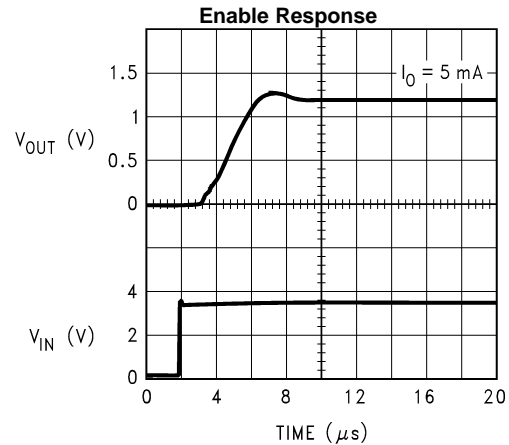

Figure 13.

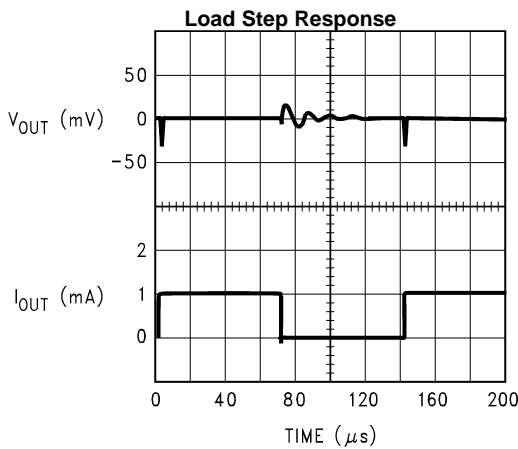

Figure 14.

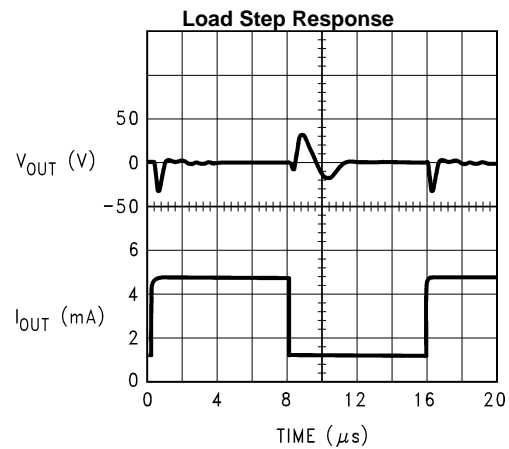

Figure 15.

**LM4121- (All Options) Typical Operating Characteristics (continued)**

Unless otherwise specified,  $V_{IN} = 3.3V$ ,  $V_{OUT} = 1.25V$ ,  $I_{LOAD} = 0$ ,  $C_{OUT} = 0.022\mu F$ ,  $T_A = 25^\circ C$  and  $V_{EN} = V_{IN}$ .

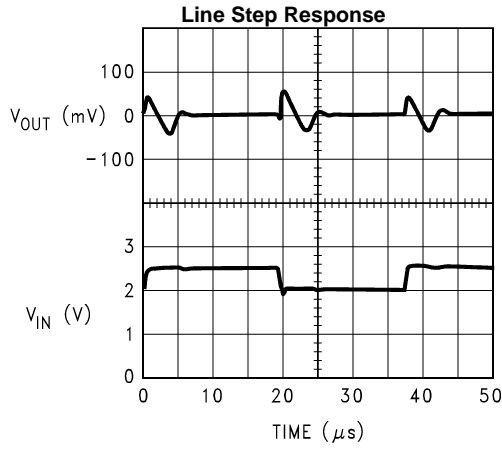

Figure 16.

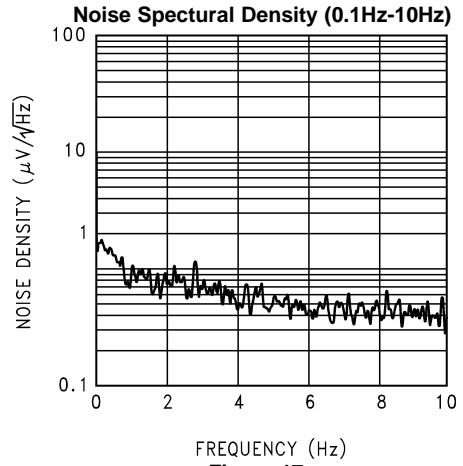

Figure 17.

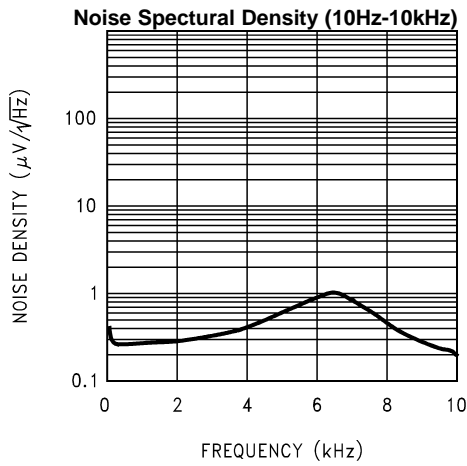

Figure 18.

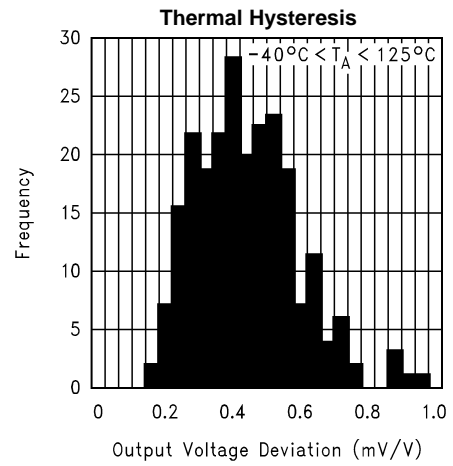

Figure 19.

### LM4121-1.25 Typical Operating Characteristics

Unless otherwise specified,  $V_{IN} = 3.3V$ ,  $V_{OUT} = 1.25V$ ,  $I_{LOAD} = 0$ ,  $C_{OUT} = 0.022\mu F$ ,  $T_A = 25^\circ C$  and  $V_{EN} = V_{IN}$ .

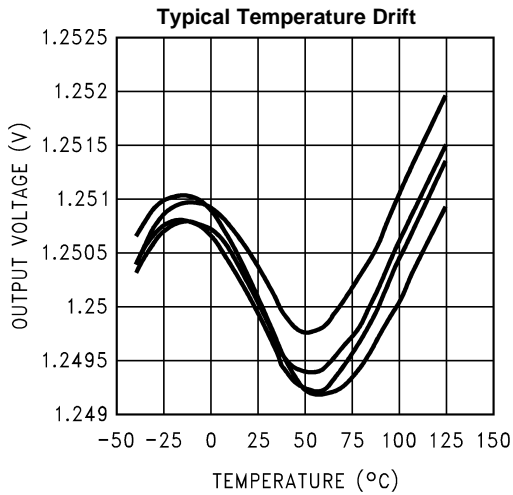

Figure 20.

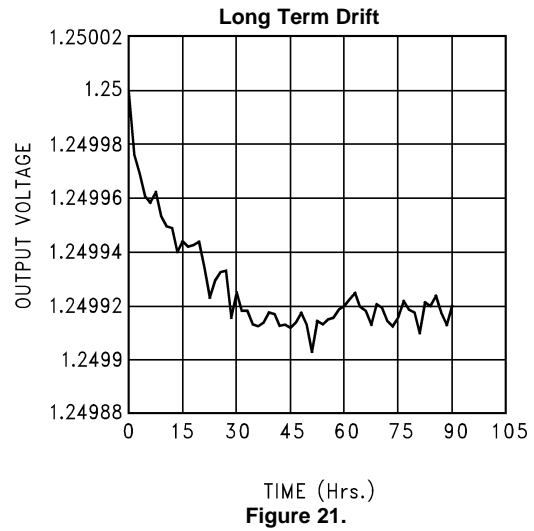

Figure 21.

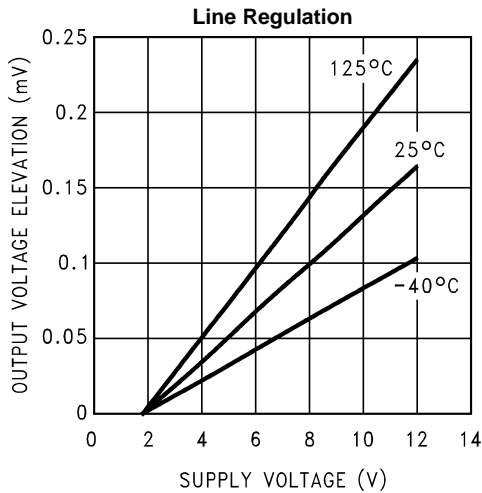

Figure 22.

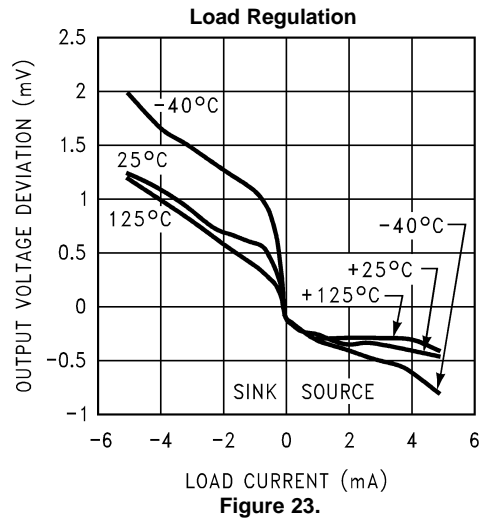

Figure 23.

**LM4121-ADJ Typical Operating Characteristics**

Unless otherwise specified,  $V_{IN} = 3.3V$ ,  $V_{OUT} = 1.2V$ ,  $I_{LOAD} = 0$ ,  $C_{OUT} = 0.022\mu F$ ,  $T_A = 25^\circ C$  and  $V_{EN} = V_{IN}$ .

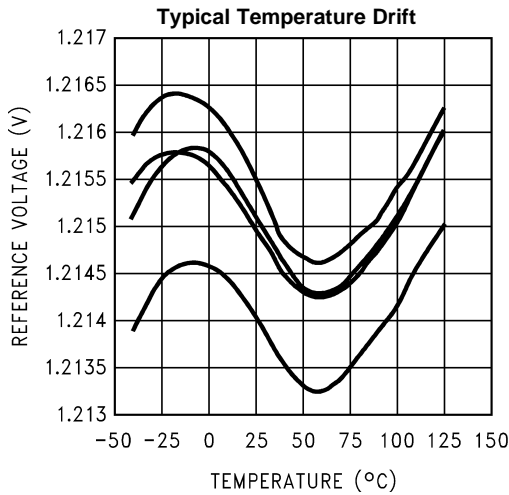

Figure 24.

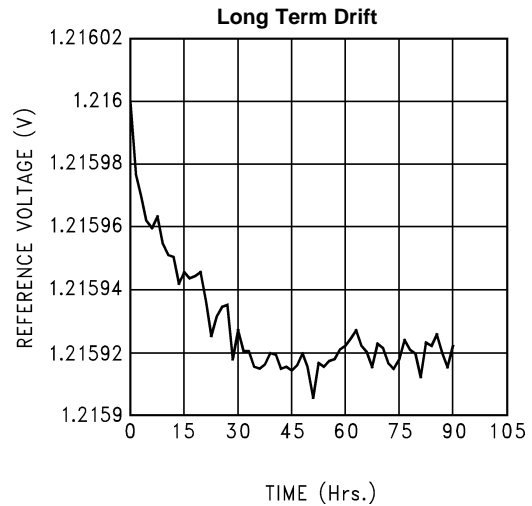

Figure 25.

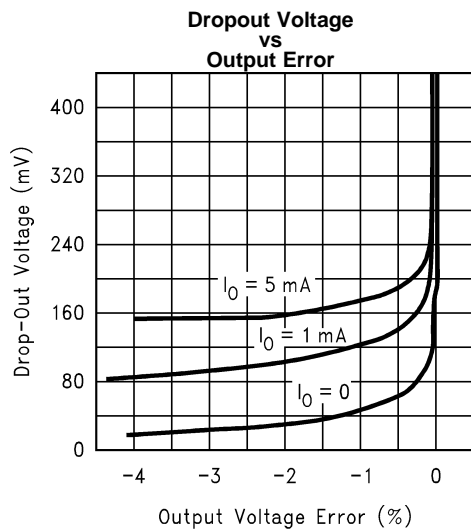

Figure 26.

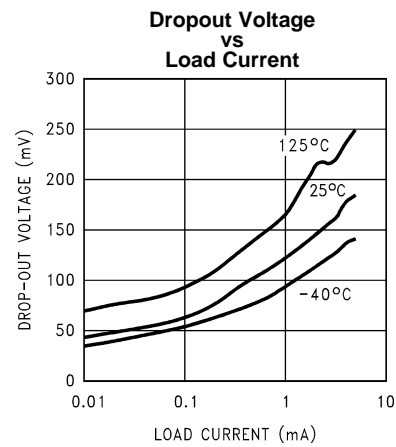

Figure 27.

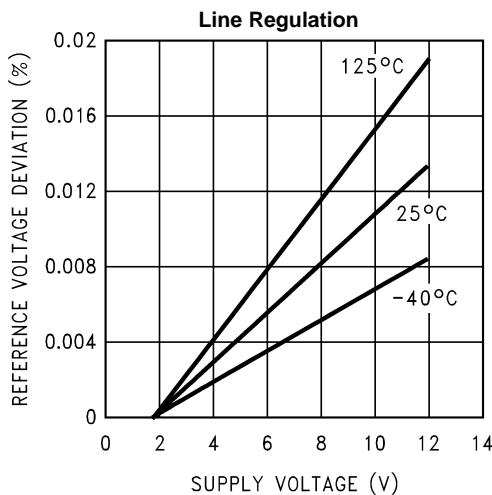

Figure 28.

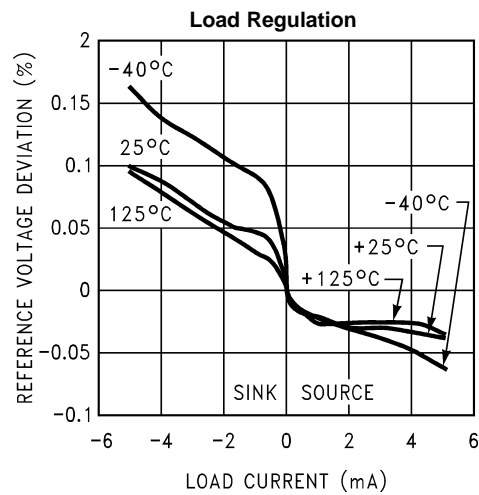

Figure 29.

**LM4121-ADJ Typical Operating Characteristics (continued)**

Unless otherwise specified,  $V_{IN} = 3.3V$ ,  $V_{OUT} = 1.2V$ ,  $I_{LOAD} = 0$ ,  $C_{OUT} = 0.022\mu F$ ,  $T_A = 25^\circ C$  and  $V_{EN} = V_{IN}$ .

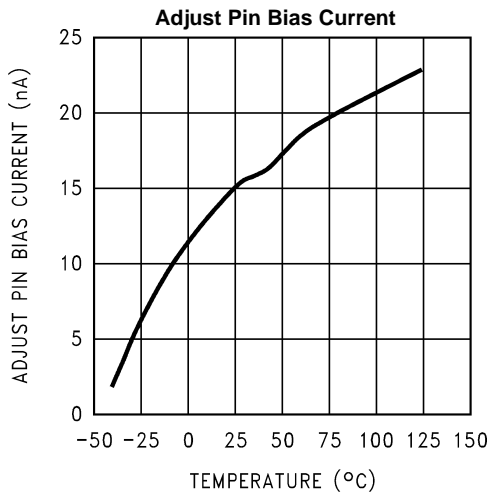

Figure 30.

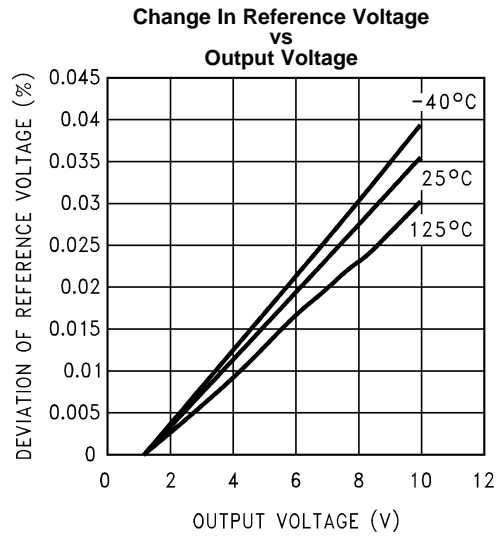

Figure 31.

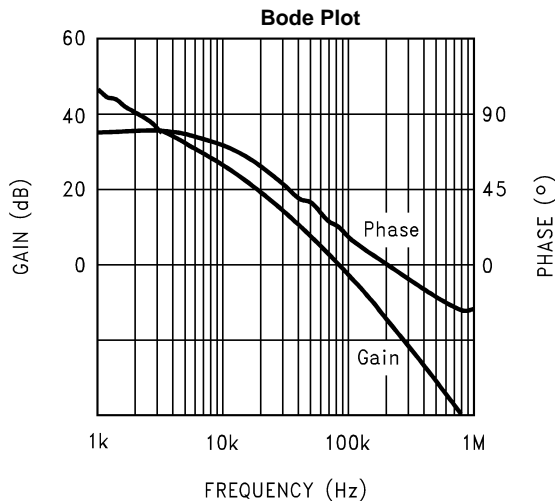

Figure 32.

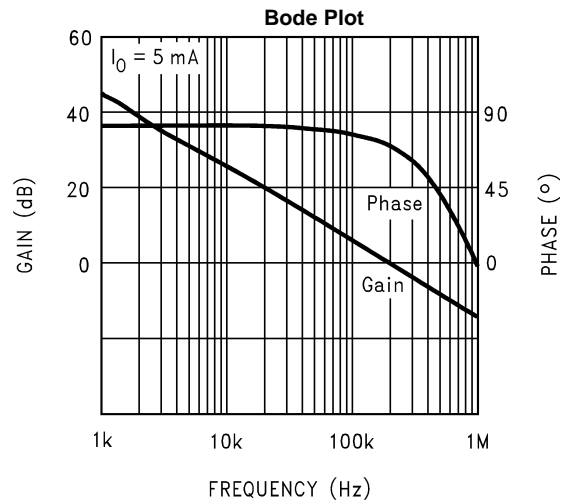

Figure 33.

### PIN DESCRIPTIONS

<b>Output (Pin 5)</b>	Reference Output.
<b>Input (Pin 4)</b>	Positive Supply.
<b>Ground (Pin 2)</b>	Negative Supply or Ground Connection
<b>Enable (Pin 3)</b>	Pulled to input for normal operation. Forcing this pin to ground will turn-off the output.
<b>REF (Pin 1)</b>	REF Pin (1.25V option only). This pin should be left unconnected for 1.25V option.
<b>Adj (Pin 1)</b>	V <sub>OUT</sub> Adj Pin (Adjustable option only). See <a href="#">Application Hints</a> section.

### APPLICATION HINTS

The standard application circuit for the LM4121 is shown in [Figure 34](#). The output voltage is set with the two feedback resistors, according to the following formula:

$$V_{OUT} = [V_{ref}(1 + R1/R2)] - I_{bias} \cdot R1 \quad (1)$$

Values for R1 and R2 should be chosen to be less than 1 MΩ. I<sub>bias</sub> typically flows out of the adjust pin. Values for V<sub>ref</sub> and I<sub>bias</sub> are found in the [Electrical Characteristics - LM4121-1.250V](#) and [Electrical Characteristics - LM4121-ADJ](#) tables. For best accuracy, be sure to take into account the variation of V<sub>REF</sub> with input voltage, load and output voltage.

The LM4121 is designed to be stable with ceramic output capacitors in the range of 0.022μF to 0.047μF. Note that 0.022μF is the minimum required output capacitor. These capacitors typically have an ESR of about 0.1 to 0.5Ω. Smaller ESR can be tolerated, however larger ESR can not. The output capacitor can be increased to improve load transient response, up to about 1μF. However, values above 0.047μF must be tantalum. With tantalum capacitors, in the 1μF range, a small capacitor between the output and the reference (Adj) pin is required. This capacitor will typically be in the 50pF range. Care must be taken when using output capacitors of 1μF or larger. These application must be thoroughly tested over temperature, line and load. Also, when the LM4121 is used as a controller, with external active components, each application must be carefully tested to ensure a stable design. The adjust pin is sensitive to noise and capacitive loading. The trace to this pin must be as short as possible and the feedback resistors should be close to this pin. Also, a single point ground to the LM4121 will help ensure good accuracy at high load currents.

An input capacitor is typically not required. However, a 0.1μF ceramic can be used to help prevent line transients from entering the LM4121. Larger input capacitors should be tantalum or aluminium.

The enable pin is an analog input with very little hysteresis. About 6μA into this pin is required to turn the part on, and it must be taken close to GND to turn the part off (see [Electrical Characteristics - LM4121-1.250V](#) and [Electrical Characteristics - LM4121-ADJ](#) tables for thresholds). There is a *minimum* slew rate on this pin of about 0.003V/μS to prevent glitches on the output. All of these conditions can easily be met with ordinary CMOS or TTL logic. If the shutdown feature is not required, then this pin can safely be connected directly to the input supply. Floating this pin is not recommended.

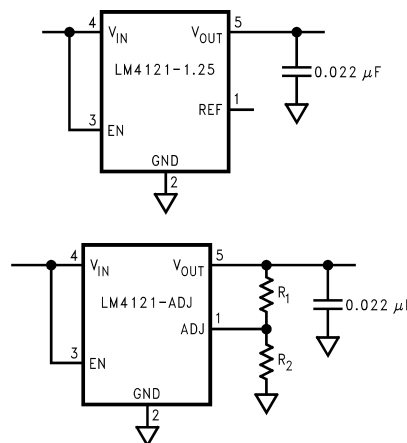

**Figure 34. Standard Application Circuit**

## PRINTED CIRCUIT BOARD LAYOUT CONSIDERATION

The mechanical stress due to PC board mounting can cause the output voltage to shift from its initial value. References in SOT packages are generally less prone to assembly stress than devices in Small Outline (SOIC) package.

To reduce the stress-related output voltage shifts, mount the reference on the low flex areas of the PC board such as near to the edge or the corner of the PC board.

## Typical Application Circuits

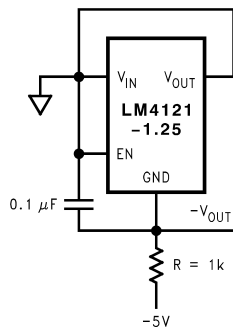

Figure 35. Voltage Reference with Negative Output

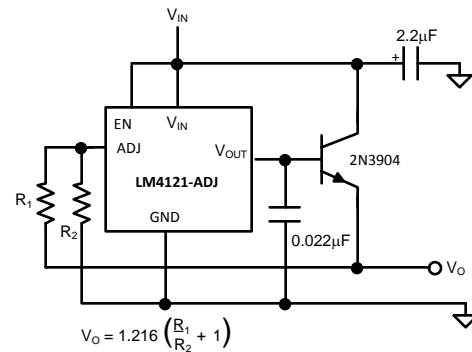

Figure 36. 100mA Quasi-LDO Regulator

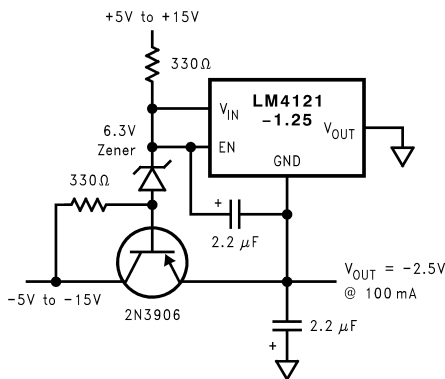

Figure 37. Boosted Output Current with Negative Voltage Reference

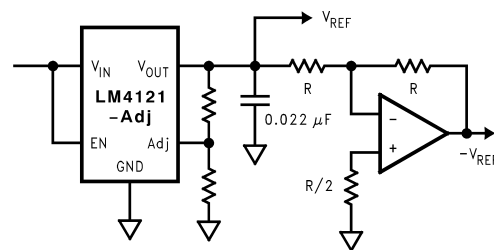

Figure 38. Voltage Reference with Complimentary Output

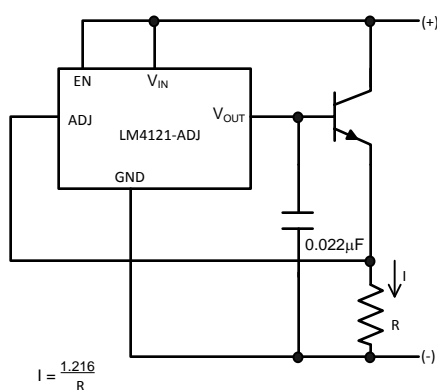

Figure 39. Two Terminal Constant Current Source

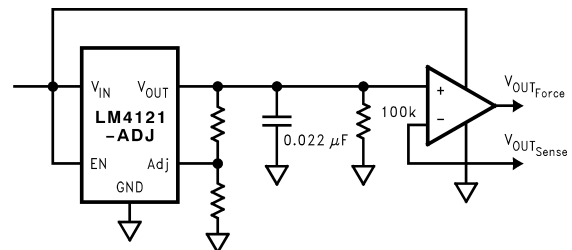

Figure 40. Precision Voltage Reference with Force and Sense Output

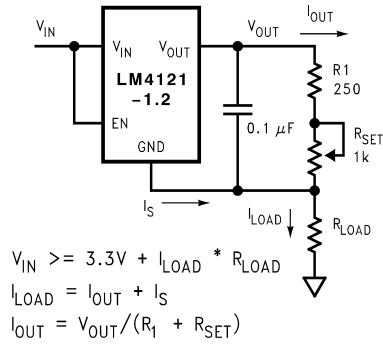

Figure 41. Programmable Current Source

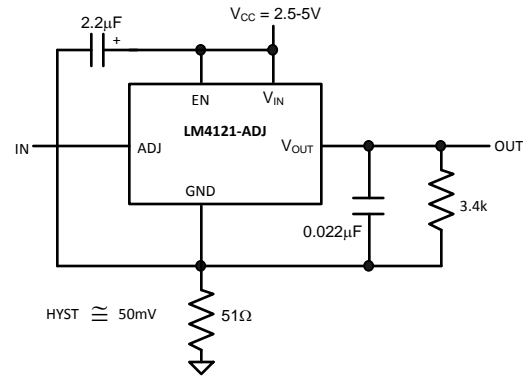

Figure 42. Precision Comparator with Hysteresis

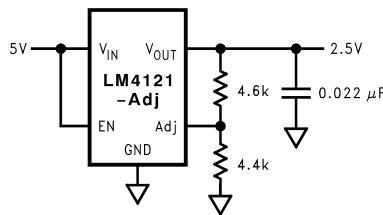

Figure 43. Power Supply Splitter

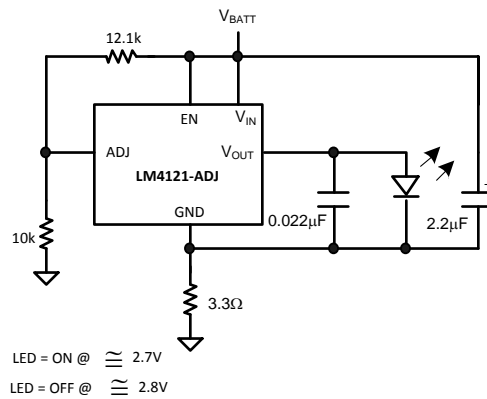

Figure 44. Li + Low Battery Detector

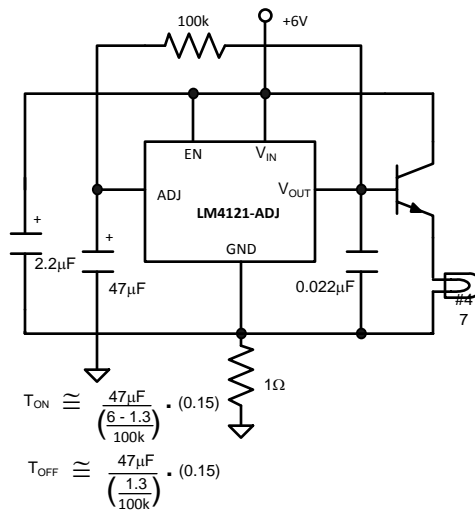

Figure 45. Flasher Circuit

---

**REVISION HISTORY**

<b>Changes from Revision B (April 2013) to Revision C</b>	<b>Page</b>
• Changed layout of National Data Sheet to TI format .....	<a href="#">14</a>

---

**PACKAGING INFORMATION**

Orderable Device	Status (1)	Package Type	Package Drawing	Pins	Package Qty	Eco Plan (2)	Lead/Ball Finish (6)	MSL Peak Temp (3)	Op Temp (°C)	Device Marking (4/5)	Samples
LM4121AIM5-1.2/NOPB	ACTIVE	SOT-23	DBV	5	1000	Green (RoHS & no Sb/Br)	CU SN	Level-1-260C-UNLIM	-40 to 85	R19A	<a href="#">Samples</a>
LM4121AIM5-ADJ/NOPB	ACTIVE	SOT-23	DBV	5	1000	Green (RoHS & no Sb/Br)	CU SN	Level-1-260C-UNLIM	-40 to 85	R20A	<a href="#">Samples</a>
LM4121AIM5X-ADJ/NOPB	ACTIVE	SOT-23	DBV	5	3000	Green (RoHS & no Sb/Br)	CU SN	Level-1-260C-UNLIM	-40 to 85	R20A	<a href="#">Samples</a>
LM4121IM5-1.2/NOPB	ACTIVE	SOT-23	DBV	5	1000	Green (RoHS & no Sb/Br)	CU SN	Level-1-260C-UNLIM	-40 to 85	R19B	<a href="#">Samples</a>
LM4121IM5-ADJ/NOPB	ACTIVE	SOT-23	DBV	5	1000	Green (RoHS & no Sb/Br)	CU SN	Level-1-260C-UNLIM	-40 to 85	R20B	<a href="#">Samples</a>
LM4121IM5X-ADJ/NOPB	ACTIVE	SOT-23	DBV	5	3000	Green (RoHS & no Sb/Br)	CU SN	Level-1-260C-UNLIM	-40 to 85	R20B	<a href="#">Samples</a>

(1) The marketing status values are defined as follows:

**ACTIVE:** Product device recommended for new designs.

**LIFEBUY:** TI has announced that the device will be discontinued, and a lifetime-buy period is in effect.

**NRND:** Not recommended for new designs. Device is in production to support existing customers, but TI does not recommend using this part in a new design.

**PREVIEW:** Device has been announced but is not in production. Samples may or may not be available.

**OBSELETE:** TI has discontinued the production of the device.

(2) Eco Plan - The planned eco-friendly classification: Pb-Free (RoHS), Pb-Free (RoHS Exempt), or Green (RoHS & no Sb/Br) - please check <http://www.ti.com/productcontent> for the latest availability information and additional product content details.

**TBD:** The Pb-Free/Green conversion plan has not been defined.

**Pb-Free (RoHS):** TI's terms "Lead-Free" or "Pb-Free" mean semiconductor products that are compatible with the current RoHS requirements for all 6 substances, including the requirement that lead not exceed 0.1% by weight in homogeneous materials. Where designed to be soldered at high temperatures, TI Pb-Free products are suitable for use in specified lead-free processes.

**Pb-Free (RoHS Exempt):** This component has a RoHS exemption for either 1) lead-based flip-chip solder bumps used between the die and package, or 2) lead-based die adhesive used between the die and leadframe. The component is otherwise considered Pb-Free (RoHS compatible) as defined above.

**Green (RoHS & no Sb/Br):** TI defines "Green" to mean Pb-Free (RoHS compatible), and free of Bromine (Br) and Antimony (Sb) based flame retardants (Br or Sb do not exceed 0.1% by weight in homogeneous material)

(3) MSL, Peak Temp. - The Moisture Sensitivity Level rating according to the JEDEC industry standard classifications, and peak solder temperature.

(4) There may be additional marking, which relates to the logo, the lot trace code information, or the environmental category on the device.

(5) Multiple Device Markings will be inside parentheses. Only one Device Marking contained in parentheses and separated by a "~" will appear on a device. If a line is indented then it is a continuation of the previous line and the two combined represent the entire Device Marking for that device.

<sup>(6)</sup> Lead/Ball Finish - Orderable Devices may have multiple material finish options. Finish options are separated by a vertical ruled line. Lead/Ball Finish values may wrap to two lines if the finish value exceeds the maximum column width.

**Important Information and Disclaimer:** The information provided on this page represents TI's knowledge and belief as of the date that it is provided. TI bases its knowledge and belief on information provided by third parties, and makes no representation or warranty as to the accuracy of such information. Efforts are underway to better integrate information from third parties. TI has taken and continues to take reasonable steps to provide representative and accurate information but may not have conducted destructive testing or chemical analysis on incoming materials and chemicals. TI and TI suppliers consider certain information to be proprietary, and thus CAS numbers and other limited information may not be available for release.

In no event shall TI's liability arising out of such information exceed the total purchase price of the TI part(s) at issue in this document sold by TI to Customer on an annual basis.

**TAPE AND REEL INFORMATION**

**QUADRANT ASSIGNMENTS FOR PIN 1 ORIENTATION IN TAPE**

\*All dimensions are nominal

Device	Package Type	Package Drawing	Pins	SPQ	Reel Diameter (mm)	Reel Width W1 (mm)	A0 (mm)	B0 (mm)	K0 (mm)	P1 (mm)	W (mm)	Pin1 Quadrant
LM4121AIM5-1.2/NOPB	SOT-23	DBV	5	1000	178.0	8.4	3.2	3.2	1.4	4.0	8.0	Q3
LM4121AIM5-ADJ/NOPB	SOT-23	DBV	5	1000	178.0	8.4	3.2	3.2	1.4	4.0	8.0	Q3
LM4121AIM5X-ADJ/NOPB	SOT-23	DBV	5	3000	178.0	8.4	3.2	3.2	1.4	4.0	8.0	Q3
LM4121IM5-1.2/NOPB	SOT-23	DBV	5	1000	178.0	8.4	3.2	3.2	1.4	4.0	8.0	Q3
LM4121IM5-ADJ/NOPB	SOT-23	DBV	5	1000	178.0	8.4	3.2	3.2	1.4	4.0	8.0	Q3
LM4121IM5X-ADJ/NOPB	SOT-23	DBV	5	3000	178.0	8.4	3.2	3.2	1.4	4.0	8.0	Q3

**TAPE AND REEL BOX DIMENSIONS**

\*All dimensions are nominal

Device	Package Type	Package Drawing	Pins	SPQ	Length (mm)	Width (mm)	Height (mm)
LM4121AIM5-1.2/NOPB	SOT-23	DBV	5	1000	210.0	185.0	35.0
LM4121AIM5-ADJ/NOPB	SOT-23	DBV	5	1000	210.0	185.0	35.0
LM4121AIM5X-ADJ/NOPB	SOT-23	DBV	5	3000	210.0	185.0	35.0
LM4121IM5-1.2/NOPB	SOT-23	DBV	5	1000	210.0	185.0	35.0
LM4121IM5-ADJ/NOPB	SOT-23	DBV	5	1000	210.0	185.0	35.0
LM4121IM5X-ADJ/NOPB	SOT-23	DBV	5	3000	210.0	185.0	35.0



# EXAMPLE BOARD LAYOUT

DBV0005A

SOT-23 - 1.45 mm max height

SMALL OUTLINE TRANSISTOR



LAND PATTERN EXAMPLE  
EXPOSED METAL SHOWN  
SCALE:15X

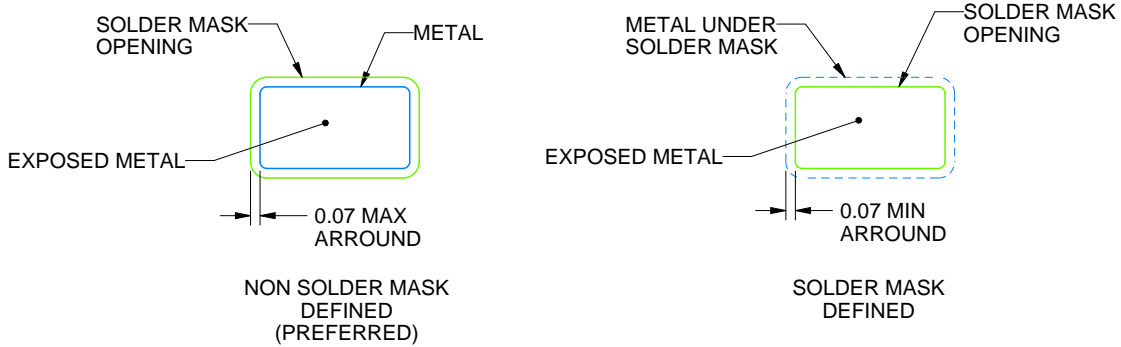

SOLDER MASK DETAILS

4214839/D 11/2018

NOTES: (continued)

- 5. Publication IPC-7351 may have alternate designs.
- 6. Solder mask tolerances between and around signal pads can vary based on board fabrication site.

# EXAMPLE STENCIL DESIGN

DBV0005A

SOT-23 - 1.45 mm max height

SMALL OUTLINE TRANSISTOR



SOLDER PASTE EXAMPLE  
BASED ON 0.125 mm THICK STENCIL  
SCALE:15X

4214839/D 11/2018

NOTES: (continued)

7. Laser cutting apertures with trapezoidal walls and rounded corners may offer better paste release. IPC-7525 may have alternate design recommendations.
8. Board assembly site may have different recommendations for stencil design.

## IMPORTANT NOTICE AND DISCLAIMER

TI PROVIDES TECHNICAL AND RELIABILITY DATA (INCLUDING DATASHEETS), DESIGN RESOURCES (INCLUDING REFERENCE DESIGNS), APPLICATION OR OTHER DESIGN ADVICE, WEB TOOLS, SAFETY INFORMATION, AND OTHER RESOURCES "AS IS" AND WITH ALL FAULTS, AND DISCLAIMS ALL WARRANTIES, EXPRESS AND IMPLIED, INCLUDING WITHOUT LIMITATION ANY IMPLIED WARRANTIES OF MERCHANTABILITY, FITNESS FOR A PARTICULAR PURPOSE OR NON-INFRINGEMENT OF THIRD PARTY INTELLECTUAL PROPERTY RIGHTS.

These resources are intended for skilled developers designing with TI products. You are solely responsible for (1) selecting the appropriate TI products for your application, (2) designing, validating and testing your application, and (3) ensuring your application meets applicable standards, and any other safety, security, or other requirements. These resources are subject to change without notice. TI grants you permission to use these resources only for development of an application that uses the TI products described in the resource. Other reproduction and display of these resources is prohibited. No license is granted to any other TI intellectual property right or to any third party intellectual property right. TI disclaims responsibility for, and you will fully indemnify TI and its representatives against, any claims, damages, costs, losses, and liabilities arising out of your use of these resources.

TI's products are provided subject to TI's Terms of Sale ([www.ti.com/legal/termsofsale.html](http://www.ti.com/legal/termsofsale.html)) or other applicable terms available either on [ti.com](http://ti.com) or provided in conjunction with such TI products. TI's provision of these resources does not expand or otherwise alter TI's applicable warranties or warranty disclaimers for TI products.

Mailing Address: Texas Instruments, Post Office Box 655303, Dallas, Texas 75265  
Copyright © 2019, Texas Instruments Incorporated

## Looking for pricing, stock, or lifecycle information?

Click below to explore more details on WIN SOURCE:

- ⊖ [View LM4121IM5-1.2/NOPB on WIN SOURCE](#)
- ⊖ [Texas Instruments](#) Information

## Optimize Your Supply Chain with WIN SOURCE Solutions

- ✓ Global Sourcing Solution
- ✓ Obsolete Management
- ✓ Cost Control Management
- ✓ Shortage Management
- ✓ Alternative Solution
- ✓ Excess Inventory Management