



# THE DATASHEET OF LM5007MM



## LM5007 75-V, 0.5-A DC/DC Buck Converter With 80-V Integrated Power MOSFET

### 1 Features

- Versatile Synchronous Buck DC/DC Converter
  - Operating Input Voltage Range of 9 V to 75 V
  - Integrated 80-V, 0.7-A N-Channel Buck Switch
  - Internal High-Voltage  $V_{CC}$  Regulator
  - Adjustable Output Voltage
  - High Efficiency Operation
- Adaptive Constant On-Time Control Architecture
  - Ultra-Fast Transient Response
  - No Control Loop Compensation Required
- Nearly Constant Switching Frequency
  - PWM On-Time Varies Inversely with Input Voltage
- Precision 2.5-V Reference
- Low Input Quiescent Current
- Inherent Protection Features for Robust Design
  - Intelligent Current Limit Protection
  - VCC and Gate Drive UVLO Protection
  - Thermal Shutdown Protection With Hysteresis
  - External Shutdown Control
- 8-Pin VSSOP and WSON Packages
- Create a Custom Regulator Design Using [WEBENCH® Power Designer](#)

### 2 Applications

- Non-Isolated DC/DC Buck Regulator
- Secondary High-Voltage Post Regulator
- 48-V Automotive Systems

### 3 Description

The LM5007 0.5-A step-down switching converter features all of the functions needed to implement a low-cost and efficient buck regulator. This high-voltage converter has an integrated 80-V, 0.7-A N-channel buck switch and operates over an input voltage range of 9 V to 75 V. The device is easy to implement and is provided in 8-pin VSSOP and thermally enhanced 8-pin WSON packages.

The converter uses a hysteretic control scheme with a PWM on-time inversely proportional to  $V_{IN}$ . This feature allows the operating frequency to remain relatively constant with load and input voltage variations. The hysteretic control requires no loop compensation and provides fast transient response. An intelligent current limit is implemented with forced off-time that is inversely proportional to  $V_{OUT}$ . This current limiting scheme ensures short-circuit protection while providing reduced load current foldback. Other protection features include thermal shutdown with automatic recovery,  $V_{CC}$  and gate drive undervoltage lockout, and maximum duty cycle limiter.

#### Device Information<sup>(1)</sup>

PART NUMBER	PACKAGE	BODY SIZE (NOM)
LM5007	VSSOP (8)	3.00 mm x 3.00 mm
	WSON (8)	4.00 mm x 4.00 mm

(1) For all available packages, see the orderable addendum at the end of the data sheet.

#### Typical Application Schematic

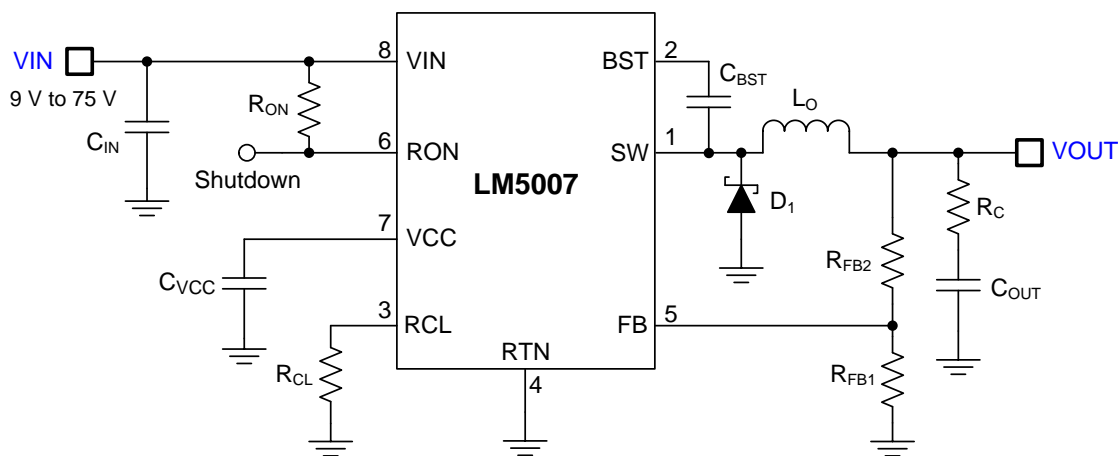

## Table of Contents

<b>1 Features</b> .....	<b>1</b>	7.4 Device Functional Modes.....	<b>12</b>
<b>2 Applications</b> .....	<b>1</b>	<b>8 Application and Implementation</b> .....	<b>13</b>
<b>3 Description</b> .....	<b>1</b>	8.1 Application Information.....	<b>13</b>
<b>4 Revision History</b> .....	<b>2</b>	8.2 Typical Application .....	<b>13</b>
<b>5 Pin Configuration and Functions</b> .....	<b>3</b>	<b>9 Power Supply Recommendations</b> .....	<b>17</b>
<b>6 Specifications</b> .....	<b>4</b>	<b>10 Layout</b> .....	<b>18</b>
6.1 Absolute Maximum Ratings .....	<b>4</b>	10.1 Layout Guidelines .....	<b>18</b>
6.2 ESD Ratings.....	<b>4</b>	10.2 Layout Example .....	<b>18</b>
6.3 Recommended Operating Conditions.....	<b>4</b>	<b>11 Device and Documentation Support</b> .....	<b>19</b>
6.4 Thermal Information .....	<b>4</b>	11.1 Device Support.....	<b>19</b>
6.5 Electrical Characteristics.....	<b>5</b>	11.2 Documentation Support .....	<b>19</b>
6.6 Typical Characteristics .....	<b>6</b>	11.3 Community Resources.....	<b>20</b>
<b>7 Detailed Description</b> .....	<b>7</b>	11.4 Trademarks .....	<b>20</b>
7.1 Overview .....	<b>7</b>	11.5 Electrostatic Discharge Caution.....	<b>20</b>
7.2 Functional Block Diagram .....	<b>7</b>	11.6 Glossary .....	<b>20</b>
7.3 Feature Description.....	<b>8</b>	<b>12 Mechanical, Packaging, and Orderable Information</b> .....	<b>21</b>

## 4 Revision History

NOTE: Page numbers for previous revisions may differ from page numbers in the current version.

<b>Changes from Revision G (October 2015) to Revision H</b>	<b>Page</b>
• Changed <i>Features</i> , editorial .....	<b>1</b>
• Changed <i>Typical Application Schematic</i> , editorial.....	<b>1</b>
• Changed <i>Overcurrent Protection</i> , editorial .....	<b>10</b>
• Changed <i>Figure 7</i> , editorial .....	<b>13</b>
• Changed <i>Power Supply Recommendations</i> , editorial .....	<b>17</b>
• Changed <i>Layout Example</i> to specify recommended component placement .....	<b>18</b>
• Changed <i>Device Support</i> to include new content .....	<b>19</b>
• Changed <i>Documentation Support</i> to include new content .....	<b>19</b>

<b>Changes from Revision F (March 2013) to Revision G</b>	<b>Page</b>
• Added <i>Device Information</i> table, <i>ESD Ratings</i> table, <i>Thermal Information</i> table, <i>Application Information</i> , <i>Design Requirements</i> , <i>Application Curves</i> , <i>Power Supply Recommendations</i> , <i>Layout</i> , and <i>Community Resources</i> . .....	<b>1</b>
• Added <i>Typical Application Schematic</i> .....	<b>1</b>
• Updated pinout drawing description .....	<b>3</b>

<b>Changes from Revision E (March 2013) to Revision F</b>	<b>Page</b>
• Changed layout of National Semiconductor Data Sheet to TI format .....	<b>11</b>

## 5 Pin Configuration and Functions

**DGK Package and NGT Package  
8-Pin VSSOP and 8-Pin WSON  
Top View**

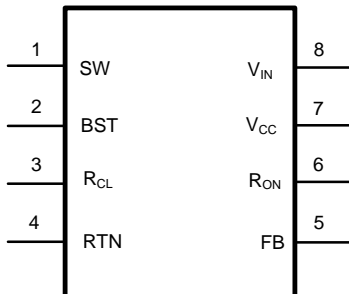

**Pin Functions**

PIN		TYPE	DESCRIPTION	APPLICATION INFORMATION
NO	NAME			
1	SW	O	Switching node.	Power switching node. Connect to the LC output filter.
2	BST	I	Boost bootstrap capacitor input.	An external capacitor is required between the BST and SW pins. A 0.01- $\mu$ F ceramic capacitor is recommended. An internal diode between $V_{CC}$ and BST completes the buck gate drive bias network.
3	$R_{CL}$	I	Current Limit OFF-time programming pin $t_{OFF} = 10^{-5} / (0.59 + (V_{FB} / 7.22 \times 10^{-6} \times R_{CL}))$	A resistor between this pin and RTN determines the variation of off-time along with the FB pin voltage per cycle while in current limit. The off-time is preset to 17 $\mu$ s if $FB = 0$ V and decreases as the FB voltage increases.
4	RTN	—	Circuit ground.	
5	FB	I	Feedback signal from regulated output.	This pin is connected to the inverting input of the internal regulation comparator. The regulation threshold is 2.5 V.
6	$R_{ON}$	I	On-time set pin $t_{ON} = 1.42 \times 10^{-10} R_{ON} / V_{IN}$	A resistor between this pin and $V_{IN}$ sets the switch on-time as a function of $V_{IN}$ . The minimum recommended on-time is 300 ns at the maximum input voltage.
7	$V_{CC}$	O	Output from the internal high-voltage bias regulator. $V_{CC}$ is nominally regulated to 7 V.	If an auxiliary voltage is available to raise the voltage on this pin, above the regulation set point (7V), the internal series pass regulator will shutdown, reducing the IC power dissipation. Do not exceed 14V. This output provides gate drive power for the internal buck switch. An internal diode is provided between this pin and the BST pin. A local 0.1- $\mu$ F decoupling capacitor is recommended. The series pass regulator is current limited to 10 mA.
8	$V_{IN}$	I	Input supply voltage.	Recommended operating range: 9 V to 75 V.
—	EP	—	Exposed PAD, underside of the WSON-8 package option.	Internally bonded to the die substrate. Connect to GND potential for low thermal impedance.

## 6 Specifications

### 6.1 Absolute Maximum Ratings

Over operating free-air temperature range (unless otherwise noted)<sup>(1)</sup>.

	MIN	MAX	UNIT
V <sub>IN</sub> to RTN		80	V
BST to RTN		94	V
SW to RTN (steady state)	-1		V
BST to V <sub>CC</sub>		80	V
BST to SW		14	V
V <sub>CC</sub> to RTN		14	V
All other inputs to RTN	-0.3	7	V
Lead temperature (soldering 4 sec)		260	°C
T <sub>stg</sub> Storage temperature	-55	150	°C

- (1) Stresses beyond those listed under *Absolute Maximum Ratings* may cause permanent damage to the device. These are stress ratings only, which do not imply functional operation of the device at these or any other conditions beyond those indicated under *Recommended Operating Conditions*. Exposure to absolute-maximum-rated conditions for extended periods may affect device reliability.

### 6.2 ESD Ratings

	VALUE	UNIT
V <sub>(ESD)</sub> Electrostatic discharge	Human-body model (HBM), per ANSI/ESDA/JEDEC JS-001 <sup>(1)(2)</sup>	±2000
	Machine model (MM)	±200

- (1) JEDEC document JEP155 states that 500-V HBM allows safe manufacturing with a standard ESD control process.  
 (2) The human body model is a 100-pF capacitor discharge through a 1.5-kΩ resistor into each pin. The machine model is a 200-pF capacitor discharged directly into each pin. The machine model ESD compliance level for Pin 5 is 150 V. The human body ESD compliance level for Pin 7 and 8 is 1000 V.

### 6.3 Recommended Operating Conditions

Over operating free-air temperature range (unless otherwise noted).

	MIN	NOM	MAX	UNIT
V <sub>IN</sub> Input voltage	9		75	V
T <sub>J</sub> Junction temperature	-40		125	°C

### 6.4 Thermal Information

THERMAL METRIC <sup>(1)</sup>	LM5007		UNIT
	DGK (VSSOP)	NGT (WSON)	
	8 PINS	8 PINS	
R <sub>θJA</sub> Junction-to-ambient thermal resistance	158.3	38.1	°C/W
R <sub>θJC(top)</sub> Junction-to-case (top) thermal resistance	51.3	27.8	°C/W
R <sub>θJB</sub> Junction-to-board thermal resistance	78.5	15.1	°C/W
ψ <sub>JT</sub> Junction-to-top characterization parameter	4.9	0.2	°C/W
ψ <sub>JB</sub> Junction-to-board characterization parameter	77.2	15.3	°C/W
R <sub>θJC(bot)</sub> Junction-to-case (bottom) thermal resistance	N/A	4.5	°C/W

- (1) For more information about traditional and new thermal metrics, see the *Semiconductor and IC Package Thermal Metrics* application report (SPRA953).

## 6.5 Electrical Characteristics

 At  $T_J = 25^\circ\text{C}$ ,  $V_{IN} = 48\text{ V}$  (unless otherwise noted)<sup>(1)</sup>.

PARAMETER		TEST CONDITIONS	MIN	TYP	MAX	UNIT
<b>STARTUP REGULATOR</b>						
$V_{CC}$	$V_{CC}$ Regulator Output		6.6	7	7.4	V
$I_{VCC-CL}$	$V_{CC}$ Current Limit <sup>(2)</sup>			11		mA
<b><math>V_{CC}</math> SUPPLY</b>						
$V_{CC-UVLO}$	$V_{CC}$ Undervoltage Lockout Voltage ( $V_{CC}$ increasing)			6.3		V
$V_{CC-UVLO-HYS}$	$V_{CC}$ Undervoltage Hysteresis			206		mV
$t_{VCC-UV-DELAY}$	$V_{CC}$ UVLO Delay (filter)			3		$\mu\text{s}$
$I_{CC-OPER}$	$I_{CC}$ Operating Current	Not switching, $V_{FB} = 3\text{ V}$		500	675	$\mu\text{A}$
$I_{SHD}$	Shutdown/Standby Current	$V_{RON} = 0\text{ V}$		100	200	$\mu\text{A}$
<b>SWITCH CHARACTERISTICS</b>						
$R_{DS(on)1}$	Buck Switch On-State Resistance	$I_{SW} = 0.2\text{ A}$ , $V_{BST} - V_{SW} = 6.3\text{ V}$ <sup>(3)</sup>		0.74	1.34	$\Omega$
$V_{GATE-UV}$	Gate Drive UVLO ( $V_{BST} - V_{SW}$ )	Rising	3.4	4.5	5.5	V
$V_{GATE-UV-HYS}$	Gate Drive UVLO Hysteresis			400		mV
$V_{DS(max)}$	Breakdown Voltage, $V_{IN}$ to RTN	$T_J = 25^\circ\text{C}$		80		V
		$T_J = -40^\circ\text{C}$ to $125^\circ\text{C}$		76		V
$V_{BST-VCC(max)}$	Breakdown voltage, BST to $V_{CC}$	$T_J = 25^\circ\text{C}$		80		V
		$T_J = -40^\circ\text{C}$ to $125^\circ\text{C}$		76		V
<b>CURRENT LIMIT</b>						
$I_{CL}$	Current Limit Threshold		535	725	900	mA
$t_{CL-RESP}$	Current Limit Response Time	$I_{SW}$ overdrive = 0.1 A, time to switch off		225		ns
$t_{CL-OFF1}$	OFF-Time Generator (test 1)	$V_{FB} = 0\text{ V}$ , $R_{CL} = 100\text{ k}\Omega$		17		$\mu\text{s}$
$t_{CL-OFF2}$	OFF-Time Generator (test 2)	$V_{FB} = 2.3\text{ V}$ , $R_{CL} = 100\text{ k}\Omega$		2.65		$\mu\text{s}$
<b>ON-TIME GENERATOR</b>						
$t_{ON1}$	TON-1	$V_{IN} = 10\text{ V}$ , $R_{ON} = 200\text{ k}\Omega$	2.15	2.77	3.5	$\mu\text{s}$
$t_{ON2}$	TON-2	$V_{IN} = 75\text{ V}$ , $R_{ON} = 200\text{ k}\Omega$	290	390	490	ns
$V_{SHD}$	Remote Shutdown Threshold	Rising	0.45	0.7	1.1	V
$V_{SHD-HYS}$	Remote Shutdown Hysteresis			40		mV
<b>MINIMUM OFF-TIME</b>						
$t_{OFF(min)}$	Minimum Off-Timer	$V_{FB} = 0\text{ V}$		300		ns
<b>REGULATION AND OV COMPARATORS</b>						
$V_{REF}$	FB Reference Threshold	Internal reference, trip point for switch ON	2.445	2.5	2.550	V
$V_{OV-REF}$	FB Overvoltage Threshold	Trip point for switch OFF		2.875		V
$I_{FB}$	FB Bias Current			100		nA
<b>THERMAL SHUTDOWN</b>						
$T_{SHD}$	Thermal Shutdown Temperature			165		$^\circ\text{C}$
$T_{HYS}$	Thermal Shutdown Hysteresis			25		$^\circ\text{C}$

- (1) All electrical characteristics having room temperature limits are tested during production with  $T_A = T_J = 25^\circ\text{C}$ . All hot and cold limits are specified by correlating the electrical characteristics to process and temperature variations and applying statistical process control.
- (2) The  $V_{CC}$  output is intended as a self bias for the internal gate drive power and control circuits. Device thermal limitations limit external loading.
- (3) For devices in the WSON-8 package, the MOSFET  $R_{DS(on)}$  limits are specified by design characterization data only.

### 6.6 Typical Characteristics

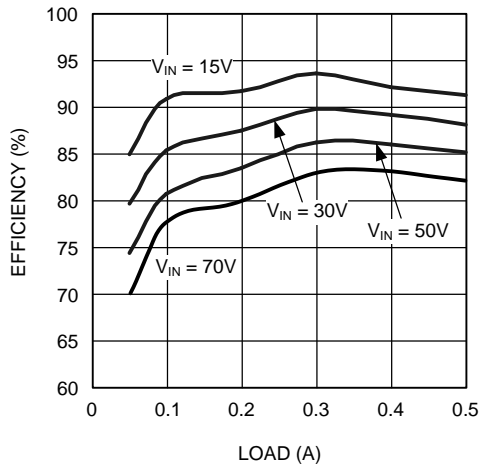

Figure 1. Converter Efficiency at 10-V Output

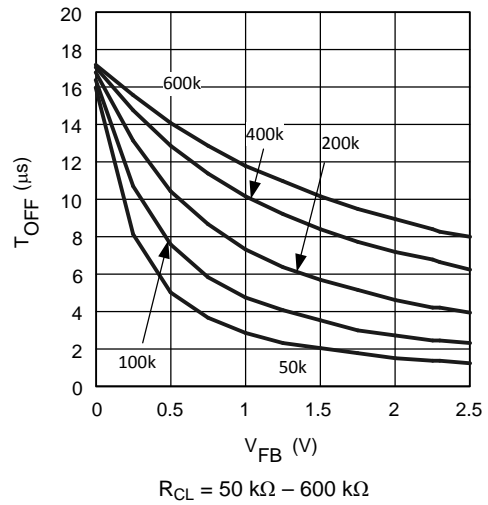

Figure 2. Current Limit T<sub>OFF</sub> vs. V<sub>FB</sub>

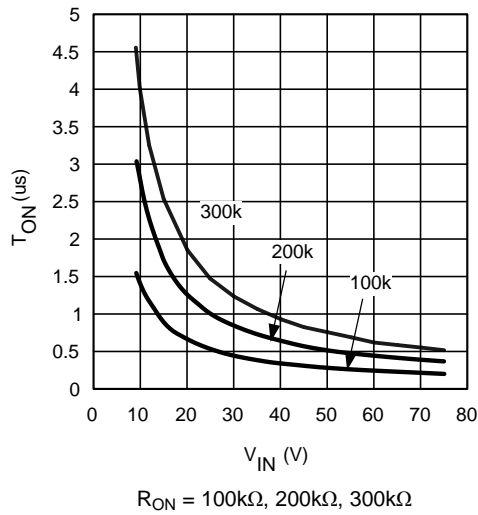

Figure 3. T<sub>ON</sub> vs. V<sub>IN</sub>

## 7 Detailed Description

### 7.1 Overview

The LM5007 regulator is an easy-to-use buck DC/DC converter that operates from 9-V to 75-V supply voltage. The device is intended for step-down conversions from 12-V, 24-V, and 48-V unregulated, semi-regulated and fully-regulated supply rails. With integrated 80-V, 0.7-A buck power MOSFET, the LM5007 delivers up to 500-mA DC load current with exceptional efficiency and low input quiescent current in a very small solution size. The device is easy to use and is provided in VSSOP-8 and thermally-enhanced WSON-8 packages. Designed for simple implementation, a nearly fixed-frequency, constant on-time (COT) operation with discontinuous conduction mode (DCM) at light loads is ideal for low-noise, high current, fast transient load requirements. Control loop compensation is not required, reducing design time and external component count. An intelligent current limit scheme is implemented in the LM5007 with forced off-time after current limit detection, which is inversely proportional to  $V_{OUT}$ . This current limiting scheme reduces load current foldback.

The LM5007 incorporates numerous other features for comprehensive system requirements, including VCC undervoltage lockout (UVLO), gate drive UVLO, maximum duty cycle limiter, intelligent current limit off-timer, and thermal shutdown with automatic recovery. These features enable a flexible and easy-to-use platform for a wide range of applications, such as 48-V telecom and the 48-V automotive power bus designs. The pin arrangement is designed for simple and optimized PCB layout, requiring only a few external components.

### 7.2 Functional Block Diagram

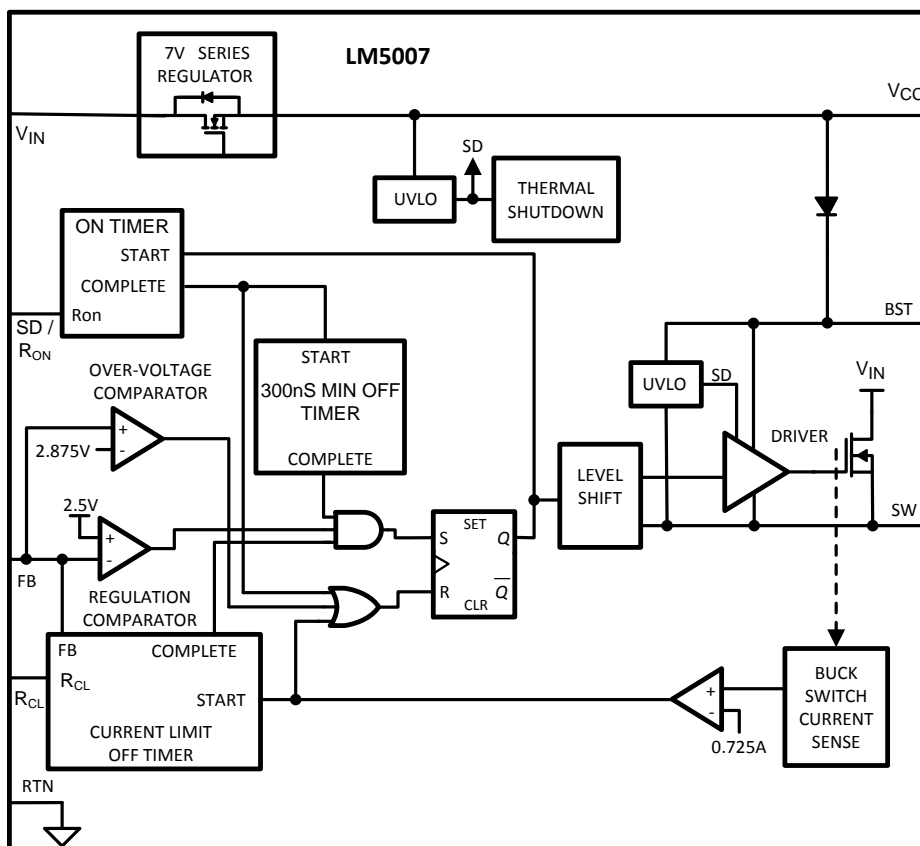

## 7.3 Feature Description

### 7.3.1 Hysteretic Control Circuit Overview

The LM5007 is a buck DC/DC converter that uses a constant on-time (COT) control scheme. The on-time is programmed by an external resistor and varies inversely with line input voltage ( $V_{IN}$ ). The core regulation elements of the LM5007 are the feedback comparator and the programmed on-time one-shot. The regulator output voltage is sensed at the feedback pin (FB) and compared to an internal reference voltage (2.5 V). If the FB voltage is below the reference voltage, the buck switch is turned on for a fixed time interval determined by the input voltage and a programming resistor ( $R_{ON}$ ). Following the on period, the switch remains off for at least the minimum off-time interval of 300 ns. If the FB voltage is still below the reference after the 300-ns off-time, the switch turns on again for another on-time interval. This switching behavior continues until the FB voltage reaches the reference voltage level.

The LM5007 operates in discontinuous conduction mode (DCM) at light load currents and continuous conduction mode (CCM) at heavier load currents. In DCM, current through the output inductor starts at zero and ramps up to a peak value during the buck switch on-time and then back to zero during the off-time. The inductor current remains at zero until the next on-time interval begins when FB falls below the internal reference voltage. The operating frequency in DCM is relatively low and varies with load. Thus, the conversion efficiency is maintained at light loads, since the switching losses decrease with the reduction in load current and switching frequency. Calculate the approximate switching frequency in DCM with [Equation 1](#).

$$F_{SW(DCM)} = \frac{V_{OUT}^2 \cdot L_O}{R_{LOAD} \cdot R_{ON}^2} \cdot 10^{20} \quad (1)$$

In CCM, current flows continuously through the inductor and never ramps down to zero. The switching frequency in CCM is greater than that in DCM and remains relatively constant with load and line variations. Calculate the approximate switching frequency in CCM with [Equation 2](#).

$$F_{SW(CCM)} = \frac{V_{OUT}}{1.42 \cdot 10^{-10} \cdot R_{ON}} \quad (2)$$

The output voltage ( $V_{OUT}$ ) can be programmed by two external resistors as shown in [Figure 4](#). Calculate the output voltage setpoint using [Equation 3](#).

$$V_{OUT} = 2.5 \text{ V} \cdot \left( 1 + \frac{R_1}{R_2} \right) \quad (3)$$

The feedback comparator in hysteretic regulators depend upon the output ripple voltage to switch the power MOSFET on and off at regular intervals. In order for the internal comparator to respond quickly to changes in output voltage, proportional to inductor current, a minimum amount of capacitor Equivalent Series Resistance (ESR) is required. A ripple voltage of 25 mV to 50 mV is recommended at the feedback pin (FB) for stable operation. In cases where the intrinsic capacitor ESR is too small, additional series resistance may be added.

For applications where lower output voltage ripple is required, the load can be connected directly to the low ESR output capacitor as shown in [Figure 4](#). The series resistor (R) will degrade the load regulation. Another technique for enhancing the ripple voltage at FB is to place a capacitor in parallel with the upper feedback resistor, R1. The addition of this feedforward capacitor reduces the attenuation of the ripple voltage from the feedback divider.

### 7.3.2 High-Voltage Bias Supply Regulator

The LM5007 contains an internal high-voltage bias supply regulator. The input pin ( $V_{IN}$ ) can be connected directly to line voltages from 9 V to 75 V. To avoid supply voltage transients due to long lead inductances on the input pin ( $V_{IN}$ ), it is always recommended to connect a low-ESR ceramic capacitor ( $\approx 0.1 \mu\text{F}$ ) between  $V_{IN}$  and RTN, located close to the respective pins of the LM5007. The bias regulator is internally current limited to 10 mA. Upon power up, the regulator is enabled and sources current into an external capacitor connected to the  $V_{CC}$  pin. When the  $V_{CC}$  voltage reaches the regulation point of 7 V, the controller output is enabled.

An external auxiliary supply voltage can be applied to the  $V_{CC}$  pin. If this auxiliary voltage is greater than 7 V, the internal regulator will essentially shutoff, thus reducing internal power dissipation.

Feature Description (continued)

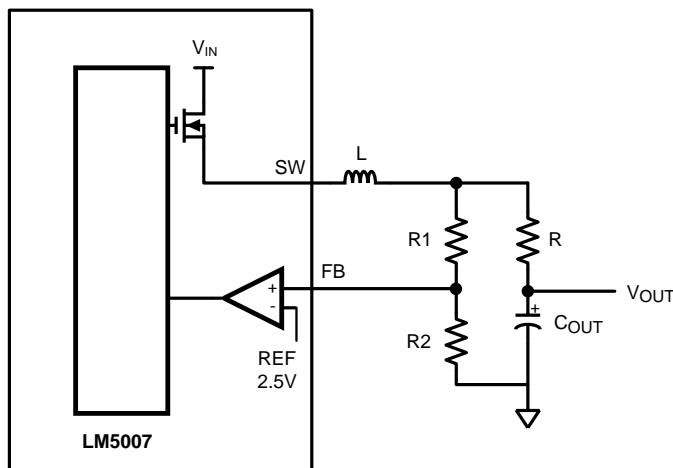

Figure 4. Low Output Ripple Voltage Configuration

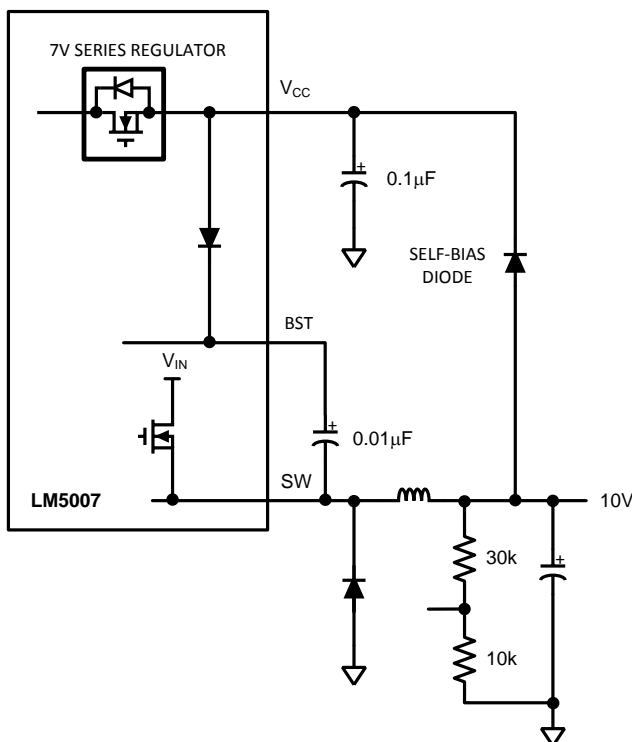

Figure 5. Self-Biased Configuration with  $V_{OUT}$  Feeding  $V_{CC}$  Through a Diode

7.3.3 Overvoltage Comparator

The overvoltage comparator is provided to protect the output from overvoltage conditions due to sudden input line voltage changes or output loading changes. The overvoltage comparator monitors the FB voltage relative to an internal 2.875-V reference,  $V_{OV-REF}$ . If the voltage at FB rises above  $V_{OV-REF}$ , the comparator immediately terminates the buck switch on-time pulse.

## Feature Description (continued)

### 7.3.4 On-Time Generator and Shutdown

The on-time of the LM5007 is set inversely proportional to the input voltage by an external resistor connected between  $V_{IN}$  and  $R_{ON}$ . The  $R_{ON}$  pin is a low impedance input biased at approximately 1.5 V. Thus, the current through the resistor and into the  $R_{ON}$  pin is approximately proportional to  $V_{IN}$  and used internally to control the on-timer. This scheme of input voltage feedforward hysteretic operation achieves nearly constant switching frequency over varying line and load conditions. Equation 4 specifies the on-time equation for the LM5007.

$$t_{ON} = 1.42 \cdot 10^{-10} \cdot \frac{R_{ON}}{V_{IN}} \quad (4)$$

The  $R_{ON}$  pin of the LM5007 also provides a shutdown function that disables the converter and significantly decreases quiescent power dissipation. Pulling the voltage at  $R_{ON}$  below a 0.7-V logic threshold activates a low-power shutdown mode. The  $V_{IN}$  quiescent current in this shutdown mode is approximately 100  $\mu$ A internal to the LM5007 plus the current in the  $R_{ON}$  resistor.

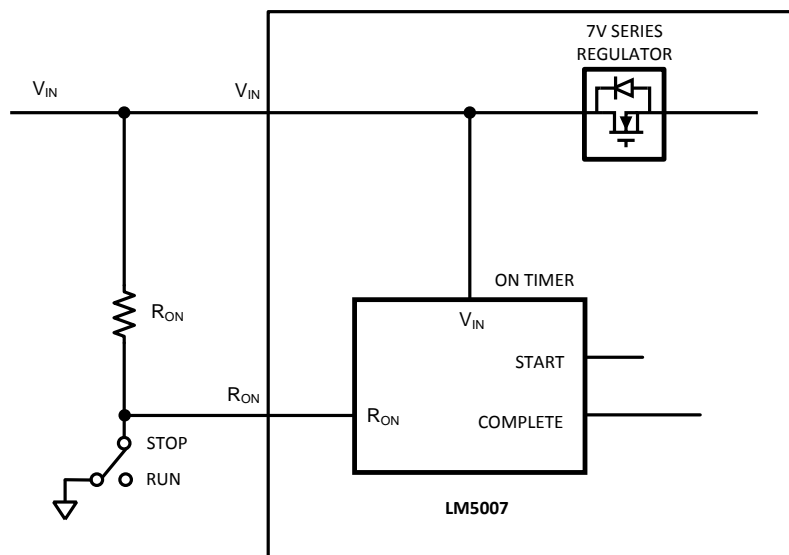

**Figure 6. Shutdown Implementation**

### 7.3.5 Overcurrent Protection

The LM5007 contains an intelligent current limit off-timer intended to reduce the foldback characteristic inherent with fixed off-time overcurrent protection (OCP) schemes. If the current in the buck switch exceeds 725 mA, the present cycle on-time is immediately terminated (cycle-by-cycle current limit). Following the termination of the cycle a non-resettable current limit off-timer is initiated. The duration of the off-time is a function of the external resistor ( $R_{CL}$ ) and the FB voltage. When the FB voltage equals zero, the current limit off-time is internally preset to 17  $\mu$ s. This condition occurs during a short-circuit condition when a maximum amount of off-time is required.

In case of output overload (not a complete short circuit), the current limit off-time is reduced as a function of the output voltage (measured at the FB pin). Scaling the off-time with smaller overloads reduces the amount of foldback and also reduces the initial start-up time. Calculate the current limit off-time for a given FB voltage and  $R_{CL}$  resistor using Equation 5.

$$t_{OFF(CL)} = \frac{10^{-5}}{0.59 + \frac{V_{FB}}{7.22 \cdot 10^{-6} \cdot R_{CL}}} \quad (5)$$

## Feature Description (continued)

Select the current limit off-time such that it is less than the MOSFET off-time during normal steady-state switching operation. Applications utilizing low-resistance inductors and/or a low-voltage-drop freewheeling power diodes may require special evaluation at high line, short-circuited conditions. In this special case the preset 17- $\mu$ s off-time ( $V_{FB} = 0$  V) may be insufficient to provide inductor volt-seconds balance. Additional inductor resistance, output resistance or a larger voltage drop diode may be necessary to balance inductor volt-seconds and limit the short-circuit current.

### 7.3.6 N-Channel Buck Switch and Driver

The LM5007 integrates an N-channel buck switch and associated floating high voltage gate driver. This gate driver circuit works in conjunction with an external bootstrap capacitor and an internal high voltage diode. The bootstrap capacitor is charged by  $V_{CC}$  through the internal high voltage diode. A 0.01- $\mu$ F ceramic capacitor connected between BST and SW is recommended.

During each cycle when the buck switch turns off, the SW voltage is approximately 0 V. When the SW voltage is low, the bootstrap capacitor is charged from  $V_{CC}$  through the internal bootstrap diode. The minimum off-timer, set to 300 ns, ensures that there is a minimum interval every switching cycle to recharge the bootstrap capacitor.

An external recirculating diode from the SW to RTN is necessary to carry the inductor current after the internal buck switch turns off. This external diode must be an ultra-fast switching or Schottky type to reduce turn-on losses and switch current overshoot. The reverse voltage rating of the recirculating diode must be greater than the maximum line input voltage.

### 7.3.7 Thermal Protection

Internal thermal shutdown circuitry is provided to protect the integrated circuit in the event the maximum junction temperature is exceeded. When thermal protection is activated, typically at 165°C, the converter is forced into a low power reset state, disabling the output driver. This feature is provided to prevent catastrophic failures from accidental device overheating.

### 7.3.8 Minimum Load Current

A minimum load current of 1 mA is required to maintain proper operation. If the load current falls below that level, the bootstrap capacitor may discharge during the long off-time, and the circuit will either shutdown or cycle on and off at a low frequency. If the load current is expected to drop below 1 mA in the application, choose the feedback resistors with sufficiently low value to provide the minimum required load current at nominal  $V_{OUT}$ .

### 7.3.9 Ripple Configuration

The LM5007 uses an adaptive constant on-time (COT) control in which the conduction time of the buck MOSFET is terminated by an on-timer and the off-time is terminated by the feedback voltage ( $V_{FB}$ ) falling below the reference voltage ( $V_{REF}$ ). Therefore, for stable operation, the feedback voltage must decrease monotonically and in phase with the inductor current during the off-time interval. Furthermore, this change in feedback voltage ( $V_{FB}$ ) during the off-time must be larger than any noise component present at the feedback node.

**Table 1** shows three different methods for generating appropriate voltage ripple at the feedback node. Type 1 and Type 2 ripple circuits couple the ripple at the output of the converter to the feedback node (FB). The output voltage ripple has two components:

1. Capacitive ripple caused by the inductor current ripple charging/discharging the output capacitor.
2. Resistive ripple caused by the inductor current ripple flowing through the ESR of the output capacitor.

The capacitive ripple is not in phase with the inductor current. As a result, the capacitive ripple does not decrease monotonically during the off-time. The resistive ripple is in phase with the inductor current and decreases monotonically during the off-time. The resistive ripple must exceed the capacitive ripple at the output node ( $V_{OUT}$ ) for stable operation. If this condition is not satisfied, unstable switching behavior is observed in COT converters with multiple on-time bursts in close succession followed by a long off-time.

## Feature Description (continued)

Type 3 ripple method uses  $R_r$  and  $C_r$  and the switch node (SW) voltage to generate a triangular ramp. This triangular ramp is ac coupled using  $C_{ac}$  to the feedback node (FB). Since this circuit does not use the output voltage ripple, it is ideally suited for applications where low output voltage ripple is required. See *AN-1481 Controlling Output Ripple and Achieving ESR Independence in Constant On-Time (COT) Regulator Designs (SNVA166)* for more details for each ripple generation method.

**Table 1. Ripple Configuration**

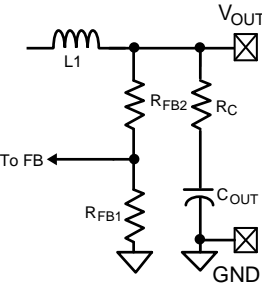
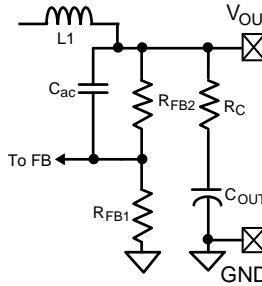
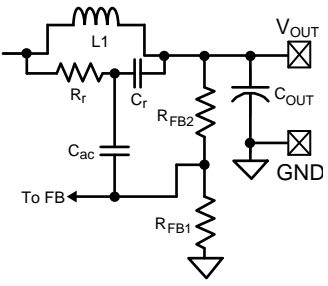
TYPE 1 LOWEST COST CONFIGURATION	TYPE 2 REDUCED RIPPLE CONFIGURATION	TYPE 3 MINIMUM RIPPLE CONFIGURATION
		
$R_C = \frac{25\text{mV}}{\Delta I_{L(\text{min})}} \cdot \frac{V_{\text{OUT}}}{V_{\text{REF}}} \quad (6)$	$C_{ac} \geq \frac{5}{F_{\text{SW}} \cdot (R_{\text{FB1}} \parallel R_{\text{FB2}})}$ $R_C = \frac{25\text{mV}}{\Delta I_{L(\text{min})}} \quad (7)$	$C_r = 3.3\text{nF}$ $C_{ac} = 100\text{nF}$ $R_r \cdot C_r = \frac{(V_{\text{IN}(\text{min})} - V_{\text{OUT}}) \cdot t_{\text{ON}}}{25\text{mV}} \quad (8)$

## 7.4 Device Functional Modes

### 7.4.1 Standby Mode with $V_{\text{IN}}$

The LM5007 is intended to operate with input voltages above 9 V. The minimum operating input voltage is determined by the  $V_{\text{CC}}$  undervoltage lockout threshold of 6.3 V (typ). If  $V_{\text{IN}}$  is too low to support a  $V_{\text{CC}}$  voltage greater than the  $V_{\text{CC}}$  UVLO threshold, the converter switches to its standby mode with the buck switch in the off state.

### 7.4.2 Shutdown Mode

The LM5007 is in shutdown mode when the  $R_{\text{ON}}$  pin is pulled below 0.7 V (typ). In this mode, the buck MOSFET is held off and the  $V_{\text{CC}}$  regulator is disabled.

## 8 Application and Implementation

### NOTE

Information in the following applications sections is not part of the TI component specification, and TI does not warrant its accuracy or completeness. TI's customers are responsible for determining suitability of components for their purposes. Customers should validate and test their design implementation to confirm system functionality.

### 8.1 Application Information

The LM5007 requires only a few external components to convert from a wide range of supply voltages to a fixed output voltage. To expedite and streamline the process of designing a LM5007-based converter, a comprehensive [LM5007 quick-start calculator](#) is available for download to assist the designer with component selection for a given application. [WEBENCH®](#) online software is also available to generate complete designs, leveraging iterative design procedures and access to comprehensive component databases. The following sections discuss a design procedure using a typical application example. [Figure 7](#) shows the LM5007 in a configuration suitable for several application use cases. See the [LM5007 EVM](#) for more details.

### 8.2 Typical Application

The application schematic of an LM5007-based buck converter is shown in [Figure 7](#). For an output voltage ( $V_{OUT}$ ) above the maximum regulation threshold of  $V_{CC}$  (see [Electrical Characteristics](#)), the  $V_{CC}$  pin can be supplied from  $V_{OUT}$  through a diode for higher efficiency and lower power dissipation in the IC.

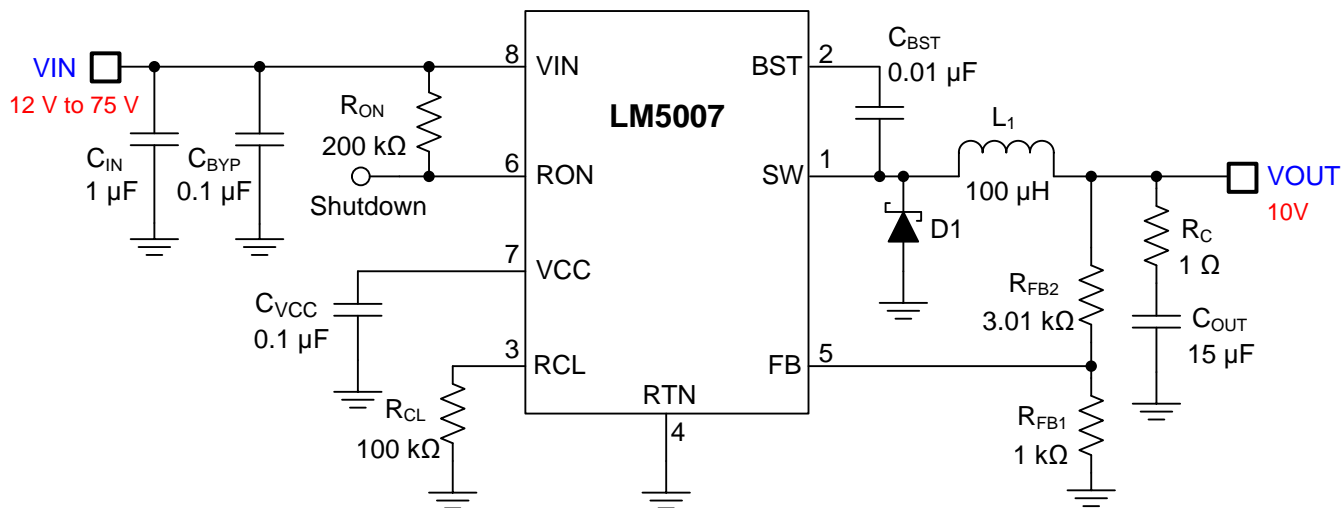

Figure 7. 12-V to 75-V Input and 10-V, 400-mA Output Buck Converter

#### 8.2.1 Design Requirements

For this design example, use the parameters listed in [Table 2](#) as the input parameters.

Table 2. Design Parameters

DESIGN PARAMETERS	VALUE
Input Voltage	12 V to 75 V
Output Voltage	10 V
Maximum Output Current	400 mA
Nominal Switching Frequency	380 kHz

## 8.2.2 Detailed Design Procedure

### 8.2.2.1 Custom Design With WEBENCH® Tools

[Click here](#) to create a custom design using the LM5007 device with WEBENCH® Power Designer.

1. Start by entering the input voltage ( $V_{IN}$ ), output voltage ( $V_{OUT}$ ), and output current ( $I_{OUT}$ ) requirements.
2. Optimize the design for key parameters such as efficiency, footprint, and cost using the optimizer dial.
3. Compare the generated design with other possible solutions from Texas Instruments.

The WEBENCH Power Designer provides a customized schematic along with a list of materials with real-time pricing and component availability.

In most cases, these actions are available:

- Run electrical simulations to see important waveforms and circuit performance
- Run thermal simulations to understand board thermal performance
- Export customized schematic and layout into popular CAD formats
- Print PDF reports for the design, and share the design with colleagues

Get more information about WEBENCH tools at [www.ti.com/WEBENCH](http://www.ti.com/WEBENCH).

### 8.2.2.2 Custom Design With Excel Quickstart Tool

Select components based on the converter specifications using the LM5007 [quick-start calculator](#) available for download from the LM5007 product folder.

### 8.2.2.3 Feedback Resistors, $R_{FB1}$ and $R_{FB2}$

$V_{OUT} = V_{FB} \times (R_{FB2}/R_{FB1} + 1)$ , and since  $V_{FB} = 2.5$  V in regulation, the ratio of  $R_{FB2}$  to  $R_{FB1}$  is 3 : 1. Select standard values of  $R_{FB1} = 1$  k $\Omega$  and  $R_{FB2} = 3.01$  k $\Omega$ . Other values can be chosen as long as the 3 : 1 ratio is maintained.

### 8.2.2.4 Switching Frequency Selection, $R_{ON}$

Set the switching frequency by resistor  $R_{ON}$  using [Equation 9](#).

$$R_{ON} = \frac{V_{OUT}}{1.42 \cdot 10^{-10} \cdot F_{SW}} \quad (9)$$

Selecting  $F_{SW} = 380$  kHz results in  $R_{ON} = 185$  k $\Omega$ . Choose a standard value of 200 k $\Omega$  for this design.

### 8.2.2.5 Buck Inductor, $L_1$

The inductor is selected to provide a current ripple of 40% to 50% of the full-load current. In addition, the peak inductor current at maximum load must be smaller than the minimum current limit threshold provided in [Electrical Characteristics](#). The inductor current ripple is given by [Equation 10](#).

$$\Delta I_L = \frac{V_{IN} - V_{OUT}}{L_1 \cdot F_{SW}} \cdot \frac{V_{OUT}}{V_{IN}} \quad (10)$$

The maximum ripple is observed at the maximum input voltage. Using  $V_{IN} = 75$  V and  $\Delta I_L = 50\% \times I_{OUT(max)}$  results in  $L_1 = 114$   $\mu$ H. Select a standard inductor value of 100  $\mu$ H. The inductor current ripple ranges from 88 mA to 228 mA depending on input voltage. The peak inductor and switch current at full load are given by [Equation 11](#).

$$I_{L1(peak)} = I_{OUT(max)} + \frac{\Delta I_L}{2} \quad (11)$$

At maximum  $V_{IN}$ , the peak inductor current is 514 mA, which is lower than the minimum current limit threshold of 535 mA. The selected inductor should be able to operate at the maximum current limit of 900 mA without saturation during startup and overload conditions.

### 8.2.2.6 Output Capacitor, $C_{OUT}$

Select the output capacitor to minimize the capacitive ripple. The maximum ripple is observed at the maximum input voltage and is given by [Equation 12](#).

$$C_{OUT} = \frac{\Delta I_L}{8 \cdot F_{SW} \cdot \Delta V_{COUT}}$$

where

- $\Delta V_{COUT}$  is the voltage ripple across the capacitor,
- $\Delta I_L$  is the peak-to-peak inductor ripple current. (12)

Substituting  $V_{IN} = 75$  V and targeting  $\Delta V_{COUT} = 10$  mV gives  $C_{OUT} = 7.5$   $\mu$ F. Select a standard 15- $\mu$ F value for  $C_{OUT}$  with X5R or X7R dielectric and a voltage rating of 16 V or higher.

### 8.2.2.7 Type I Ripple Circuit, $R_C$

Choose a type I ripple circuit, as described in [Ripple Configuration](#), for this example. For a constant on-time (COT) converter to be stable, the injected in-phase ripple must be larger than the capacitive ripple on  $C_{OUT}$ .

Using the type I ripple circuit equations with minimum FB pin ripple of 25 mV, calculate the value of series resistor  $R_C$  using [Equation 13](#).

$$R_C = \frac{25 \text{ mV}}{\Delta I_{L(\min)}} \cdot \frac{V_{OUT}}{V_{REF}} \quad (13)$$

Based on the calculated value of 1.1  $\Omega$ , select a standard value of 1  $\Omega$ .

### 8.2.2.8 Input Capacitor, $C_{IN}$

The input capacitor should be large enough to limit the input voltage ripple that can be calculated using [Equation 14](#).

$$C_{IN} = \frac{I_{OUT(\max)} \cdot D \cdot (1-D)}{F_{SW} \cdot \Delta V_{CIN}} \quad (14)$$

The input ripple reaches its maximum at  $D = 0.5$ . Targeting a  $\Delta V_{CIN} = 0.5$  V at using a duty cycle of  $D = 0.5$  results in  $C_{IN} = 0.526$   $\mu$ F. A standard value of 1  $\mu$ F is selected. The input capacitor should be rated for the maximum input voltage under all conditions. A 100-V, X7R type capacitor is selected for this design. The input capacitor should be placed close to the  $V_{IN}$  pin and the anode of the diode (D1) as it supplies high-frequency switching current.

Also place a 0.1- $\mu$ F bypass capacitor ( $C_{BYP}$ ) very close to  $V_{IN}$  and RTN pins of the IC to reduce switching power loop parasitic inductance and mitigate SW node overshoot and ringing.

### 8.2.2.9 Current Limit, $R_{CL}$

Resistor  $R_{CL}$  sets the current limit off-timer according to [Equation 5](#). The useable values tend to be in the range of 100 k $\Omega$  to 1 M $\Omega$ . [Equation 15](#) specifies the off-time required for volt-second balance on the inductor in current limit.

$$t_{OFF(LIM)} = \frac{V_{IN(\max)} \cdot 225 \text{ ns}}{V_{OUT} + V_F + I_{LIM} \cdot R_{DCR}}$$

where

- 225 ns is the current limit response time,
- $V_F$  is the forward voltage drop of the freewheeling power diode,
- $V_{OUT}$  is the output voltage,
- $I_{LIM}$  is the current limit,
- $R_{DCR}$  is the inductor DC resistance. (15)

The programmed current limit off-time should be higher than the off-time needed for volt-second balance on the inductor. For a short at the output ( $V_{OUT} = 0$  V) and  $V_F = 0.7$  V, an inductor DCR of 390 mΩ or higher is needed to achieve volt-second balance at the maximum programmed current limit off-time of 17 μs. Using Equation 5, an  $R_{CL}$  of greater than 10 kΩ can be used. Select a conservative value of 100 kΩ for this design.



For step-by-step design procedures, circuit schematics, bill of materials, PCB files, simulation and test results of LM5007-powered implementations, refer to the [TI Designs](#) reference design library.

### 8.2.3 Application Curves

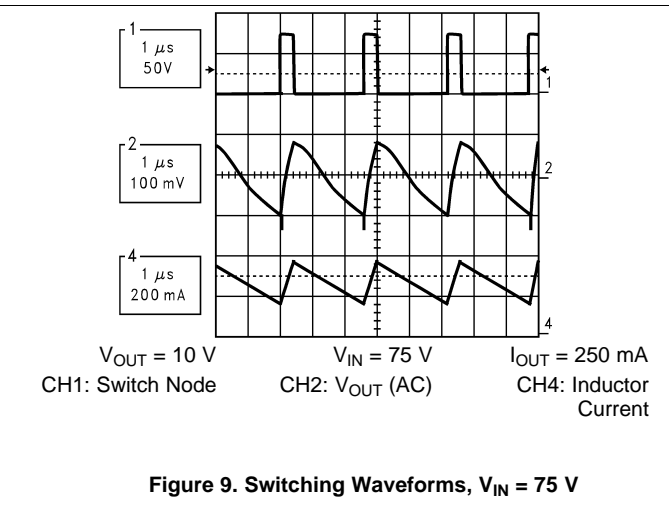
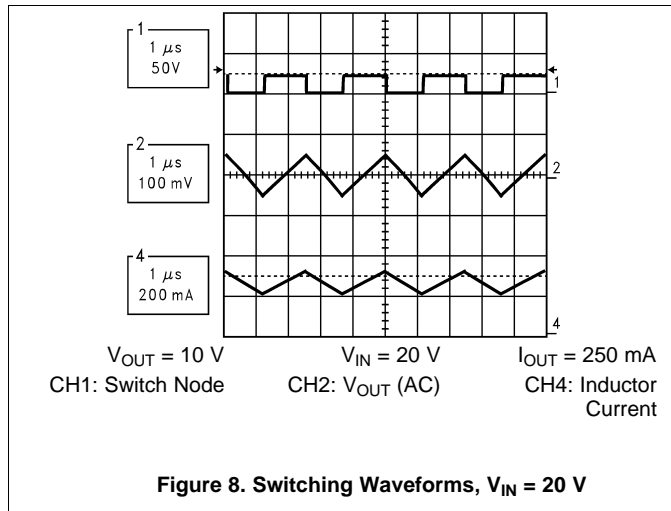

## 9 Power Supply Recommendations

The LM5007 converter is designed to operate from a wide input voltage range from 9 V to 75 V. The characteristics of the input supply must be compatible with the [Absolute Maximum Ratings](#) and [Recommended Operating Conditions](#). In addition, the input supply must be capable of delivering the required input current to the fully-loaded regulator. Estimate the average input current with [Equation 16](#).

$$I_{IN} = \frac{V_{OUT} \cdot I_{OUT}}{V_{IN} \cdot \eta}$$

where

- $\eta$  is the efficiency (16)

If the converter is connected to an input supply through long wires or PCB traces with large impedance, achieving stable performance requires special care. The parasitic inductance and resistance of the input cables may have an adverse affect on converter operation. The parasitic inductance in combination with the low-ESR ceramic input capacitors form an underdamped resonant circuit. This circuit can cause overvoltage transients at  $V_{IN}$  each time the input supply is cycled ON and OFF. The parasitic resistance causes the input voltage to dip during a load transient. If the regulator is operating close to the minimum input voltage, this dip can cause false UVLO fault triggering and a system reset. The best way to solve such issues is to reduce the distance from the input supply to the regulator and use an aluminum or tantalum input capacitor in parallel with the ceramics. The moderate ESR of the electrolytic capacitors helps to damp the input resonant circuit and reduce any voltage overshoots. A capacitance in the range of 10  $\mu$ F to 47  $\mu$ F is usually sufficient to provide input damping and helps to hold the input voltage steady during large load transients.

An EMI input filter is often used in front of the regulator that, unless carefully designed, can lead to instability as well as some of the effects mentioned above. The user's guide [Simple Success with Conducted EMI for DC-DC Converters](#) (SNVA489) provides helpful suggestions when designing an input filter for any switching regulator.

## 10 Layout

### 10.1 Layout Guidelines

The LM5007 regulation and overvoltage comparators are very fast, and as such respond to short-duration noise pulses. Layout considerations are therefore critical for optimum performance:

1. Minimize the area of the high di/dt switching current loop consisting of the VIN and SW pins, freewheeling power diode, and input ceramic capacitor. Keep the input capacitor(s) close to the VIN pin of the LM5007. Place the cathode of the freewheeling diode close to the SW pin and its anode near the return terminal of the input capacitor as illustrated in Figure 10. Route a short, direct connection to the RTN pin using polygon copper pours under the IC.
2. Place the inductor close to the SW pin of the LM5007. Minimize SW node copper area to reduce radiated noise related to high dv/dt.
3. Locate  $C_{BST}$ ,  $R_{CL}$ ,  $R_{ON}$  and  $C_{VCC}$  components as physically close as possible to their respective pins, thereby minimizing noise pickup in the printed-circuit tracks.
4. Locate the VOUT sense trace away from noise sources such as inductors. Place both feedback resistors close to the FB pin to minimize the length of the FB trace.
5. Place a solid GND plane on layer 2 of the PCB.

If the internal dissipation of the LM5007 converter produces excessive junction temperatures during normal operation, optimal use of the PCB ground plane can help considerably to dissipate heat. The exposed pad on the bottom of the WSON-8 package can be soldered to a ground plane on the PCB, and that plane should extend out from beneath the IC to help dissipate the heat. Additionally, the use of wide PCB traces for power connection can also help conduct heat away from the IC. Judicious positioning of the LM5007 converter within the end product, along with use of any available air flow (forced or natural convection), can help reduce the operating junction temperature.

### 10.2 Layout Example

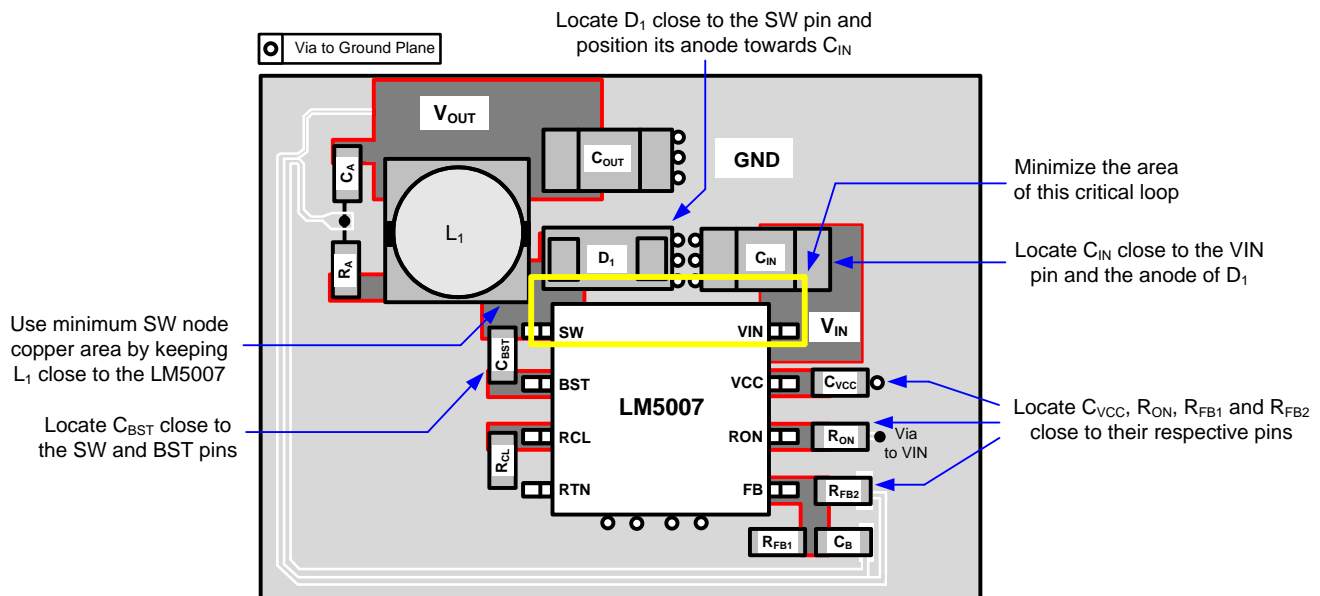

Figure 10. PCB Layout Example

#### NOTE

It is critical to minimize switching loop parasitic inductance by locating the input capacitor close to the VIN pin of the LM5007. Also, place the freewheeling power diode near the SW pin with its anode adjacent to the input capacitor as shown in Figure 10.

## 11 Device and Documentation Support

### 11.1 Device Support

#### 11.1.1 Third-Party Products Disclaimer

TI'S PUBLICATION OF INFORMATION REGARDING THIRD-PARTY PRODUCTS OR SERVICES DOES NOT CONSTITUTE AN ENDORSEMENT REGARDING THE SUITABILITY OF SUCH PRODUCTS OR SERVICES OR A WARRANTY, REPRESENTATION OR ENDORSEMENT OF SUCH PRODUCTS OR SERVICES, EITHER ALONE OR IN COMBINATION WITH ANY TI PRODUCT OR SERVICE.

#### 11.1.2 Custom Design With WEBENCH® Tools

[Click here](#) to create a custom design using the LM5007 device with the WEBENCH® Power Designer.

1. Start by entering the input voltage ( $V_{IN}$ ), output voltage ( $V_{OUT}$ ), and output current ( $I_{OUT}$ ) requirements.
2. Optimize the design for key parameters such as efficiency, footprint, and cost using the optimizer dial.
3. Compare the generated design with other possible solutions from Texas Instruments.

The WEBENCH Power Designer provides a customized schematic along with a list of materials with real-time pricing and component availability.

In most cases, these actions are available:

- Run electrical simulations to see important waveforms and circuit performance
- Run thermal simulations to understand board thermal performance
- Export customized schematic and layout into popular CAD formats
- Print PDF reports for the design, and share the design with colleagues

Get more information about WEBENCH tools at [www.ti.com/WEBENCH](http://www.ti.com/WEBENCH).

#### 11.1.3 Development Support

For development support see the following:

- For TI's reference design library, visit [TI Designs](#)
- For TI's WEBENCH Design Environments, visit [WEBENCH® Design Center](#)

## 11.2 Documentation Support

### 11.2.1 Related Documentation

For related documentation see the following:

- [LM5007 Quick-start Calculator](#)
- [LM5007EVAL Evaluation Board](#)
- [LM5007SD-EVAL Evaluation Board](#)
- [LM5006EVAL Evaluation Board](#)
- [LM5008EVAL Evaluation Board](#)
- [LM5008AEVAL Evaluation Board](#)
- [LM5009EVAL Evaluation Board](#)
- [LM5010-EVAL Evaluation Board](#)
- [LM5010AEVAL Evaluation Board](#)
- [Buck Regulator Topologies for Wide Input/Output Voltage Differentials](#) (SNVA594)
- [AN-1481 Controlling Output Ripple and Achieving ESR Independence in Constant On-Time \(COT\) Regulator Designs](#) (SNVA166)
- White Papers:
  - [Valuing Wide  \$V\_{IN}\$ , Low EMI Synchronous Buck Circuits for Cost-driven, Demanding Applications](#) (SLYY104)
  - [An Overview of Conducted EMI Specifications for Power Supplies](#) (SLYY136)
  - [An Overview of Radiated EMI Specifications for Power Supplies](#) (SLYY142)

## Documentation Support (continued)

- TI Designs:
  - [PoE PSE Type 2 \(30W\) IEEE 802.3at Fully Autonomous Quad Port Solution](#)
  - [8 Channel, 2-A High-Side Driver Reference Design for Digital Output Modules](#)
  - [Low Side 0.5A 8ch Digital Output Module for PLC](#)
  - [High Fidelity 175W Class-D Audio Amplifier with Digital Inputs and Processing Reference Design](#)
  - [Bidirectional DC-DC Converter Reference Design for 12-V/48-V Automotive Systems](#)

### 11.2.1.1 PCB Layout Resources

- [AN-1149 Layout Guidelines for Switching Power Supplies](#) (SNVA021)
- [AN-1229 Simple Switcher PCB Layout Guidelines](#) (SNVA054)
- [Constructing Your Power Supply – Layout Considerations](#) (SLUP230)
- [Low Radiated EMI Layout Made SIMPLE with LM4360x and LM4600x](#) (SNVA721)
- [AN-2162 Simple Success With Conducted EMI From DC-DC Converters](#) (SNVA489)
- [Reduce Buck-Converter EMI and Voltage Stress by Minimizing Inductive Parasitics](#) (SLYT682)
- Power House Blogs:
  - [High-Density PCB Layout of DC/DC Converters](#)

### 11.2.1.2 Thermal Design Resources

- [AN-2020 Thermal Design By Insight, Not Hindsight](#) (SNVA419)
- [AN-1520 A Guide to Board Layout for Best Thermal Resistance for Exposed Pad Packages](#) (SNVA183)
- [Semiconductor and IC Package Thermal Metrics](#) (SPRA953)
- [Thermal Design Made Simple with LM43603 and LM43602](#) (SNVA719)
- [PowerPAD™ Thermally Enhanced Package](#) (SLMA002)
- [PowerPAD Made Easy](#) (SLMA004)
- [Using New Thermal Metrics](#) (SBVA025)

## 11.3 Community Resources

The following links connect to TI community resources. Linked contents are provided "AS IS" by the respective contributors. They do not constitute TI specifications and do not necessarily reflect TI's views; see TI's [Terms of Use](#).

**TI E2E™ Online Community** *TI's Engineer-to-Engineer (E2E) Community*. Created to foster collaboration among engineers. At [e2e.ti.com](http://e2e.ti.com), you can ask questions, share knowledge, explore ideas and help solve problems with fellow engineers.

**Design Support** *TI's Design Support* Quickly find helpful E2E forums along with design support tools and contact information for technical support.

## 11.4 Trademarks

PowerPAD, E2E are trademarks of Texas Instruments.  
WEBENCH is a registered trademark of Texas Instruments.

## 11.5 Electrostatic Discharge Caution



These devices have limited built-in ESD protection. The leads should be shorted together or the device placed in conductive foam during storage or handling to prevent electrostatic damage to the MOS gates.

## 11.6 Glossary

[SLYZ022](#) — *TI Glossary*.

This glossary lists and explains terms, acronyms, and definitions.

## 12 Mechanical, Packaging, and Orderable Information

The following pages include mechanical, packaging, and orderable information. This information is the most current data available for the designated devices. This data is subject to change without notice and revision of this document. For browser-based versions of this data sheet, refer to the left-hand navigation.

## PACKAGING INFORMATION

Orderable Device	Status (1)	Package Type	Package Drawing	Pins	Package Qty	Eco Plan (2)	Lead finish/ Ball material (6)	MSL Peak Temp (3)	Op Temp (°C)	Device Marking (4/5)	Samples
LM5007MM	LIFEBUY	VSSOP	DGK	8	1000	Non-RoHS & Green	Call TI	Level-1-260C-UNLIM	-40 to 125	S81B	
LM5007MM/NOPB	ACTIVE	VSSOP	DGK	8	1000	RoHS & Green	SN	Level-1-260C-UNLIM	-40 to 125	S81B	Samples
LM5007MMX/NOPB	ACTIVE	VSSOP	DGK	8	3500	RoHS & Green	SN	Level-1-260C-UNLIM	-40 to 125	S81B	Samples
LM5007SD	LIFEBUY	WSOP	NGT	8	1000	Non-RoHS & Green	Call TI	Level-1-260C-UNLIM	-40 to 125	L00031B	
LM5007SD/NOPB	ACTIVE	WSOP	NGT	8	1000	RoHS & Green	NIPDAU   SN	Level-1-260C-UNLIM	-40 to 125	L00031B	Samples
LM5007SDX/NOPB	ACTIVE	WSOP	NGT	8	4500	RoHS & Green	NIPDAU   SN	Level-1-260C-UNLIM	-40 to 125	L00031B	Samples

(1) The marketing status values are defined as follows:

**ACTIVE:** Product device recommended for new designs.

**LIFEBUY:** TI has announced that the device will be discontinued, and a lifetime-buy period is in effect.

**NRND:** Not recommended for new designs. Device is in production to support existing customers, but TI does not recommend using this part in a new design.

**PREVIEW:** Device has been announced but is not in production. Samples may or may not be available.

**OBSOLETE:** TI has discontinued the production of the device.

(2) **RoHS:** TI defines "RoHS" to mean semiconductor products that are compliant with the current EU RoHS requirements for all 10 RoHS substances, including the requirement that RoHS substance do not exceed 0.1% by weight in homogeneous materials. Where designed to be soldered at high temperatures, "RoHS" products are suitable for use in specified lead-free processes. TI may reference these types of products as "Pb-Free".

**RoHS Exempt:** TI defines "RoHS Exempt" to mean products that contain lead but are compliant with EU RoHS pursuant to a specific EU RoHS exemption.

**Green:** TI defines "Green" to mean the content of Chlorine (Cl) and Bromine (Br) based flame retardants meet JS709B low halogen requirements of <=1000ppm threshold. Antimony trioxide based flame retardants must also meet the <=1000ppm threshold requirement.

(3) MSL, Peak Temp. - The Moisture Sensitivity Level rating according to the JEDEC industry standard classifications, and peak solder temperature.

(4) There may be additional marking, which relates to the logo, the lot trace code information, or the environmental category on the device.

(5) Multiple Device Markings will be inside parentheses. Only one Device Marking contained in parentheses and separated by a "~" will appear on a device. If a line is indented then it is a continuation of the previous line and the two combined represent the entire Device Marking for that device.

(6) Lead finish/Ball material - Orderable Devices may have multiple material finish options. Finish options are separated by a vertical ruled line. Lead finish/Ball material values may wrap to two lines if the finish value exceeds the maximum column width.

**Important Information and Disclaimer:** The information provided on this page represents TI's knowledge and belief as of the date that it is provided. TI bases its knowledge and belief on information provided by third parties, and makes no representation or warranty as to the accuracy of such information. Efforts are underway to better integrate information from third parties. TI has taken and continues to take reasonable steps to provide representative and accurate information but may not have conducted destructive testing or chemical analysis on incoming materials and chemicals. TI and TI suppliers consider certain information to be proprietary, and thus CAS numbers and other limited information may not be available for release.

In no event shall TI's liability arising out of such information exceed the total purchase price of the TI part(s) at issue in this document sold by TI to Customer on an annual basis.

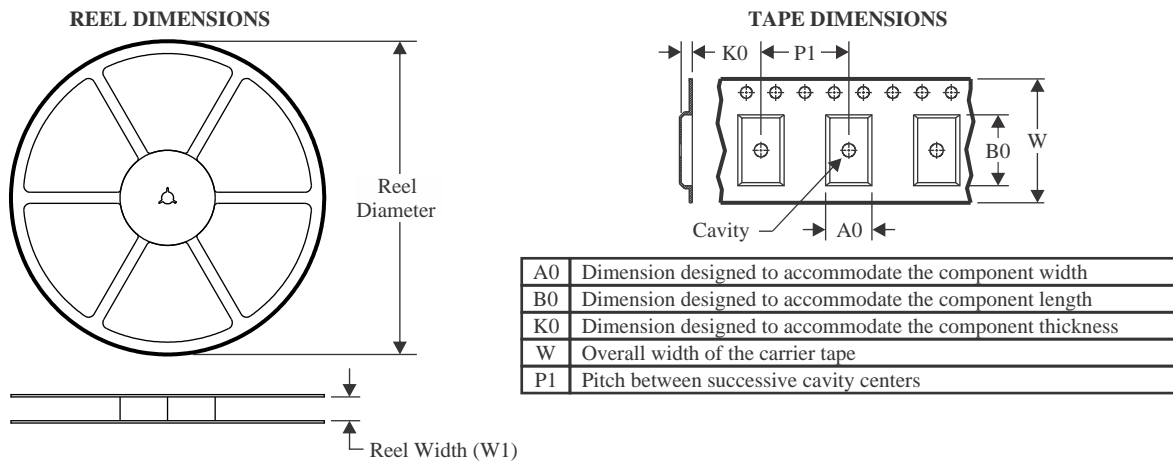
**TAPE AND REEL INFORMATION**

**QUADRANT ASSIGNMENTS FOR PIN 1 ORIENTATION IN TAPE**

\*All dimensions are nominal

Device	Package Type	Package Drawing	Pins	SPQ	Reel Diameter (mm)	Reel Width W1 (mm)	A0 (mm)	B0 (mm)	K0 (mm)	P1 (mm)	W (mm)	Pin1 Quadrant
LM5007MM	VSSOP	DGK	8	1000	178.0	12.4	5.3	3.4	1.4	8.0	12.0	Q1
LM5007MM/NOPB	VSSOP	DGK	8	1000	178.0	12.4	5.3	3.4	1.4	8.0	12.0	Q1
LM5007MMX/NOPB	VSSOP	DGK	8	3500	330.0	12.4	5.3	3.4	1.4	8.0	12.0	Q1
LM5007SD	WSO	NGT	8	1000	178.0	12.4	4.3	4.3	1.3	8.0	12.0	Q1
LM5007SD/NOPB	WSO	NGT	8	1000	178.0	12.4	4.3	4.3	1.3	8.0	12.0	Q1
LM5007SD/NOPB	WSO	NGT	8	1000	180.0	12.4	4.3	4.3	1.1	8.0	12.0	Q1
LM5007SDX/NOPB	WSO	NGT	8	4500	330.0	12.4	4.3	4.3	1.1	8.0	12.0	Q1
LM5007SDX/NOPB	WSO	NGT	8	4500	330.0	12.4	4.3	4.3	1.3	8.0	12.0	Q1

**TAPE AND REEL BOX DIMENSIONS**

\*All dimensions are nominal

Device	Package Type	Package Drawing	Pins	SPQ	Length (mm)	Width (mm)	Height (mm)
LM5007MM	VSSOP	DGK	8	1000	208.0	191.0	35.0
LM5007MM/NOPB	VSSOP	DGK	8	1000	208.0	191.0	35.0
LM5007MMX/NOPB	VSSOP	DGK	8	3500	367.0	367.0	35.0
LM5007SD	WSON	NGT	8	1000	208.0	191.0	35.0
LM5007SD/NOPB	WSON	NGT	8	1000	208.0	191.0	35.0
LM5007SD/NOPB	WSON	NGT	8	1000	200.0	183.0	25.0
LM5007SDX/NOPB	WSON	NGT	8	4500	346.0	346.0	35.0
LM5007SDX/NOPB	WSON	NGT	8	4500	367.0	367.0	35.0





# EXAMPLE STENCIL DESIGN

NGT0008A

WSON - 0.8 mm max height

PLASTIC SMALL OUTLINE - NO LEAD

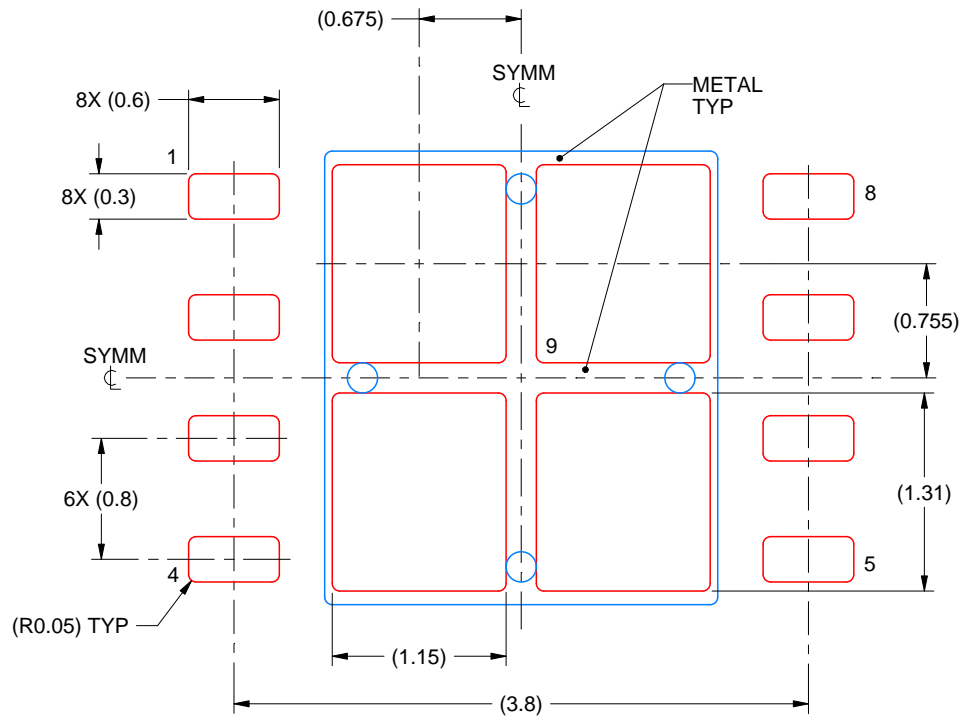

SOLDER PASTE EXAMPLE  
BASED ON 0.125 mm THICK STENCIL

EXPOSED PAD 9:  
77% PRINTED SOLDER COVERAGE BY AREA UNDER PACKAGE  
SCALE:20X

4214935/A 08/2020

NOTES: (continued)

6. Laser cutting apertures with trapezoidal walls and rounded corners may offer better paste release. IPC-7525 may have alternate design recommendations.

# DGK0008A

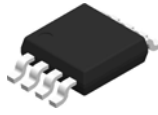

# PACKAGE OUTLINE

VSSOP - 1.1 mm max height

SMALL OUTLINE PACKAGE



4214862/A 04/2023

**NOTES:**

PowerPAD is a trademark of Texas Instruments.

1. All linear dimensions are in millimeters. Any dimensions in parenthesis are for reference only. Dimensioning and tolerancing per ASME Y14.5M.
2. This drawing is subject to change without notice.
3. This dimension does not include mold flash, protrusions, or gate burrs. Mold flash, protrusions, or gate burrs shall not exceed 0.15 mm per side.
4. This dimension does not include interlead flash. Interlead flash shall not exceed 0.25 mm per side.
5. Reference JEDEC registration MO-187.

# EXAMPLE BOARD LAYOUT

DGK0008A

™ VSSOP - 1.1 mm max height

SMALL OUTLINE PACKAGE



LAND PATTERN EXAMPLE  
EXPOSED METAL SHOWN  
SCALE: 15X

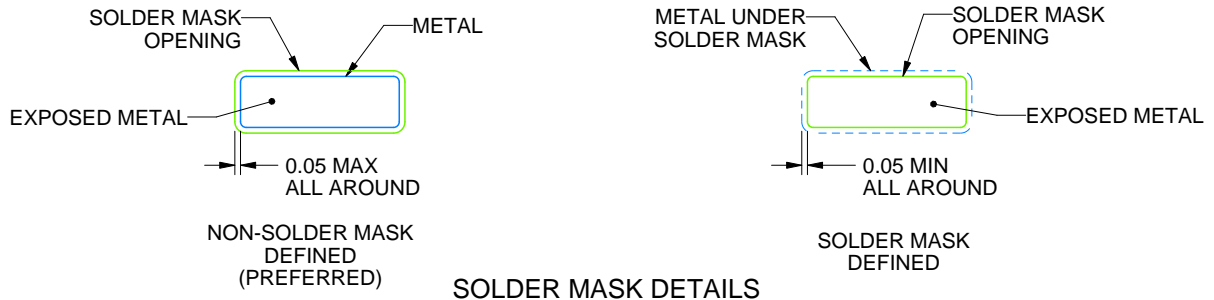

4214862/A 04/2023

NOTES: (continued)

6. Publication IPC-7351 may have alternate designs.
7. Solder mask tolerances between and around signal pads can vary based on board fabrication site.
8. Vias are optional depending on application, refer to device data sheet. If any vias are implemented, refer to their locations shown on this view. It is recommended that vias under paste be filled, plugged or tented.
9. Size of metal pad may vary due to creepage requirement.

# EXAMPLE STENCIL DESIGN

DGK0008A

<sup>TM</sup> VSSOP - 1.1 mm max height

SMALL OUTLINE PACKAGE



SOLDER PASTE EXAMPLE  
SCALE: 15X

4214862/A 04/2023

NOTES: (continued)

11. Laser cutting apertures with trapezoidal walls and rounded corners may offer better paste release. IPC-7525 may have alternate design recommendations.
12. Board assembly site may have different recommendations for stencil design.

## IMPORTANT NOTICE AND DISCLAIMER

TI PROVIDES TECHNICAL AND RELIABILITY DATA (INCLUDING DATA SHEETS), DESIGN RESOURCES (INCLUDING REFERENCE DESIGNS), APPLICATION OR OTHER DESIGN ADVICE, WEB TOOLS, SAFETY INFORMATION, AND OTHER RESOURCES "AS IS" AND WITH ALL FAULTS, AND DISCLAIMS ALL WARRANTIES, EXPRESS AND IMPLIED, INCLUDING WITHOUT LIMITATION ANY IMPLIED WARRANTIES OF MERCHANTABILITY, FITNESS FOR A PARTICULAR PURPOSE OR NON-INFRINGEMENT OF THIRD PARTY INTELLECTUAL PROPERTY RIGHTS.

These resources are intended for skilled developers designing with TI products. You are solely responsible for (1) selecting the appropriate TI products for your application, (2) designing, validating and testing your application, and (3) ensuring your application meets applicable standards, and any other safety, security, regulatory or other requirements.

These resources are subject to change without notice. TI grants you permission to use these resources only for development of an application that uses the TI products described in the resource. Other reproduction and display of these resources is prohibited. No license is granted to any other TI intellectual property right or to any third party intellectual property right. TI disclaims responsibility for, and you will fully indemnify TI and its representatives against, any claims, damages, costs, losses, and liabilities arising out of your use of these resources.

TI's products are provided subject to [TI's Terms of Sale](#) or other applicable terms available either on [ti.com](https://www.ti.com) or provided in conjunction with such TI products. TI's provision of these resources does not expand or otherwise alter TI's applicable warranties or warranty disclaimers for TI products.

TI objects to and rejects any additional or different terms you may have proposed.

Mailing Address: Texas Instruments, Post Office Box 655303, Dallas, Texas 75265  
Copyright © 2024, Texas Instruments Incorporated

## Looking for pricing, stock, or lifecycle information?

Click below to explore more details on WIN SOURCE:

 [View LM5007MM](#) on WIN SOURCE

 [Texas Instruments](#) Information

## Optimize Your Supply Chain with WIN SOURCE Solutions

-  Global Sourcing Solution
-  Obsolete Management
-  Cost Control Management
-  Shortage Management
-  Alternative Solution
-  Excess Inventory Management