



THE DATASHEET OF LM5008MM



Table of Contents

1 Features	1	7.4 Device Functional Modes	11
2 Applications	1	8 Application and Implementation	12
3 Description	1	8.1 Application Information.....	12
4 Revision History	2	8.2 Typical Application	12
5 Pin Configuration and Functions	3	9 Power Supply Recommendations	16
6 Specifications	4	10 Layout	17
6.1 Absolute Maximum Ratings	4	10.1 Layout Guidelines	17
6.2 ESD Ratings	4	10.2 Layout Examples.....	17
6.3 Recommended Operating Conditions.....	4	11 Device and Documentation Support	18
6.4 Thermal Information	4	11.1 Device Support	18
6.5 Electrical Characteristics.....	5	11.2 Documentation Support	18
6.6 Switching Characteristics	5	11.3 Receiving Notification of Documentation Updates	19
6.7 Typical Characteristics	6	11.4 Community Resources.....	19
7 Detailed Description	7	11.5 Trademarks	19
7.1 Overview	7	11.6 Electrostatic Discharge Caution.....	19
7.2 Functional Block Diagram	7	11.7 Glossary	19
7.3 Feature Description.....	8	12 Mechanical, Packaging, and Orderable Information	19

4 Revision History

NOTE: Page numbers for previous revisions may differ from page numbers in the current version.

Changes from Revision H (December 2016) to Revision I	Page
• Added links for WEBENCH	1
• Changed VSSOP-8 body size to 3 mm x 3 mm in <i>Device Information</i>	1
• Changed <i>Layout Guidelines</i>	17

Changes from Revision G (March 2013) to Revision H	Page
• Added <i>ESD Ratings</i> table, <i>Feature Description</i> section, <i>Device Functional Modes</i> , <i>Application and Implementation</i> section, <i>Power Supply Recommendations</i> section, <i>Layout</i> section, <i>Device and Documentation Support</i> section, and <i>Mechanical, Packaging, and Orderable Information</i> section	1
• Deleted Lead temperature, soldering (260°C maximum)	4
• Changed R _{θJA} values From: 200°C/W To: 139.7°C/W (VSSOP) and From: 40°C/W To: 42°C/W (WSON).....	4

Changes from Revision F (March 2013) to Revision G	Page
• Changed layout of National Semiconductor Data Sheet to TI format	1

5 Pin Configuration and Functions

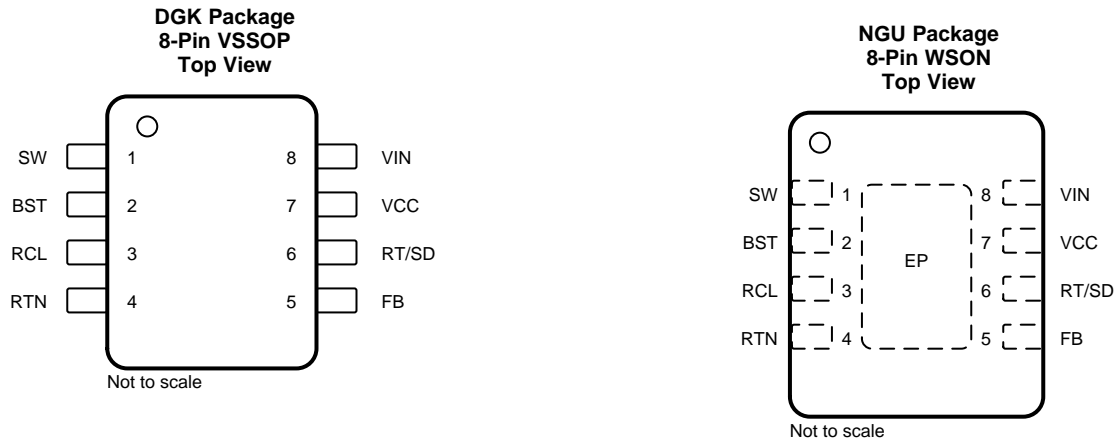

Pin Functions

PIN		TYPE	DESCRIPTION
NO.	NAME		
1	SW	P	Switching node: power switching node. Connect to the output inductor, re-circulating diode, and bootstrap capacitor.
2	BST	I	Boost pin (bootstrap capacitor input): an external capacitor is required between the BST and the SW pins. A 0.01- μ F ceramic capacitor is recommended. An internal diode charges the capacitor from V_{CC} .
3	R_{CL}	I	Current limit OFF time set pin: a resistor between this pin and RTN sets the off-time when current limit is detected. The off-time is preset to 35 μ s if $FB = 0$ V. $T_{off} = 10^{-5} / (0.285 + (FB / 6.35 \times 10^{-6} \times R_{CL}))$
4	RTN	G	Ground pin: ground for the entire circuit.
5	FB	I	Feedback input from regulated output: this pin is connected to the inverting input of the internal regulation comparator. The regulation threshold is 2.5 V.
6	R_{ON}/SD	I	On-time set pin: a resistor between this pin and V_{IN} sets the switch on-time as a function of V_{IN} . The minimum recommended on-time is 400 ns at the maximum input voltage. This pin can be used for remote shutdown. $T_{on} = 1.25 \times 10^{-10} R_{ON} / V_{IN}$
7	V_{CC}	P	Output from the internal high voltage series pass regulator. Regulated at 7 V. If an auxiliary voltage is available to raise the voltage on this pin, above the regulation set point (7 V), the internal series pass regulator will shutdown, reducing the IC power dissipation. Do not exceed 14 V. This voltage provides gate drive power for the internal buck switch. An internal diode is provided between this pin and the BST pin. A local 0.1- μ F decoupling capacitor is recommended. Series pass regulator is current limited to 10 mA.
8	V_{IN}	P	Input voltage: recommended operating range is 9.5 V to 95 V.
—	EP	G	Exposed pad: the exposed pad has no electrical contact. Connect to system ground plane for reduced thermal resistance (WSON package only).

6 Specifications

6.1 Absolute Maximum Ratings

 over operating free-air temperature range (unless otherwise noted)⁽¹⁾

	MIN	MAX	UNIT
V _{IN} to GND	−0.3	100	V
BST to GND	−0.3	114	V
SW to GND (steady-state)		−1	V
BST to V _{CC}		100	V
BST to SW		14	V
V _{CC} to GND		14	V
All other inputs to GND	−0.3	7	V
Storage temperature, T _{stg}	−55	150	°C

- (1) Stresses beyond those listed under *Absolute Maximum Ratings* may cause permanent damage to the device. These are stress ratings only, which do not imply functional operation of the device at these or any other conditions beyond those indicated under *Recommended Operating Conditions*. Exposure to absolute-maximum-rated conditions for extended periods may affect device reliability.

6.2 ESD Ratings

		VALUE	UNIT
V _(ESD) Electrostatic discharge	Human-body model (HBM), per ANSI/ESDA/JEDEC JS-001 ⁽¹⁾⁽²⁾	±2000	V
	Charged-device model (CDM), per JEDEC specification JESD22-C101 ⁽³⁾	±750	

- (1) JEDEC document JEP155 states that 500-V HBM allows safe manufacturing with a standard ESD control process.
 (2) The human body model is a 100-pF capacitor discharged through a 1.5-kΩ resistor into each pin.
 (3) JEDEC document JEP157 states that 250-V CDM allows safe manufacturing with a standard ESD control process.

6.3 Recommended Operating Conditions

over operating free-air temperature range (unless otherwise noted)

	MIN	MAX	UNIT
V _{IN}	9.5	95	V
Operating junction temperature, T _J	−40	125	°C

6.4 Thermal Information

THERMAL METRIC ⁽¹⁾		LM5008		UNIT
		DGK (VSSOP)	NGU (WSON)	
		8 PINS	8 PINS	
R _{θJA}	Junction-to-ambient thermal resistance	139.7	42	°C/W
R _{θJC(top)}	Junction-to-case (top) thermal resistance	51.2	27.6	°C/W
R _{θJB}	Junction-to-board thermal resistance	70.5	18.5	°C/W
Ψ _{JT}	Junction-to-top characterization parameter	3.4	0.3	°C/W
Ψ _{JB}	Junction-to-board characterization parameter	69.5	18.5	°C/W
R _{θJC(bot)}	Junction-to-case (bottom) thermal resistance	—	4.3	°C/W

- (1) For more information about traditional and new thermal metrics, see the [Semiconductor and IC Package Thermal Metrics](#) application report.

6.5 Electrical Characteristics

Specifications are for $T_J = 25^\circ\text{C}$ and $V_{IN} = 48\text{ V}$ (unless otherwise stated)⁽¹⁾.

PARAMETER		TEST CONDITIONS	MIN	TYP	MAX	UNIT
V_{CC} SUPPLY						
V _{CC} Reg	V _{CC} regulator output	T _J = 25°C	7			V
		T _J = -40°C to 125°C	6.6		7.4	
	V _{CC} current limit ⁽²⁾			9.5		mA
	V _{CC} undervoltage lockout voltage	V _{CC} increasing		6.3		V
	V _{CC} undervoltage hysteresis			200		mV
	V _{CC} UVLO delay (filter)	100-mV overdrive		10		μs
I _{IN} operating current	Non-switching, FB = 3 V	T _J = 25°C	485			μA
		T _J = -40°C to 125°C			675	
I _{IN} shutdown current	R _{ON} /SD = 0 V	T _J = 25°C	76			μA
		T _J = -40°C to 125°C			150	
CURRENT LIMIT						
Current limit threshold		T _J = 25°C	0.51			A
		T _J = -40°C to 125°C	0.41		0.61	
	Current limit response time	I _{switch} overdrive = 0.1 A, time to switch off		400		ns
	OFF time generator (test 1)	FB = 0 V, R _{CL} = 100 K		35		μs
	OFF time generator (test 2)	FB = 2.3 V, R _{CL} = 100 K		2.56		μs
ON-TIME GENERATOR						
T _{ON} - 1	V _{IN} = 10 V, R _{ON} = 200 K	T _J = 25°C	2.77			μs
		T _J = -40°C to 125°C	2.15		3.5	
T _{ON} - 2	V _{IN} = 95 V, R _{ON} = 200 K	T _J = 25°C	300			ns
		T _J = -40°C to 125°C	200		420	
	Remote shutdown threshold	Rising		0.7		V
	Remote shutdown hysteresis			35		mV
MINIMUM OFF-TIME						
	Minimum off-timer	FB = 0 V		300		ns
REGULATION AND OV COMPARATORS						
FB reference threshold	Internal reference, trip point for switch ON	T _J = 25°C	2.5			V
		T _J = -40°C to 125°C	2.445		2.55	
	FB overvoltage threshold	Trip point for switch OFF		2.875		V
	FB bias current			100		nA
THERMAL SHUTDOWN						
T _{sd}	Thermal shutdown temperature			165		°C
	Thermal shutdown hysteresis			25		°C

- (1) All electrical characteristics having room temperature limits are tested during production with $T_A = T_J = 25^\circ\text{C}$. All hot and cold limits are specified by correlating the electrical characteristics to process and temperature variations and applying statistical process control.
- (2) The V_{CC} output is intended as a self bias for the internal gate drive power and control circuits. Device thermal limitations limit external loading.

6.6 Switching Characteristics

over operating free-air temperature range (unless otherwise noted)

PARAMETER	TEST CONDITIONS	MIN	TYP	MAX	UNIT
Buck switch R _{DS(on)}	I _{TEST} = 200 mA ⁽¹⁾	T _J = 25°C	1.15		Ω
		T _J = -40°C to 125°C			
Gate drive UVLO	V _{BST} - V _{SW} rising	T _J = 25°C	4.5		V
		T _J = -40°C to 125°C	3.4		
Gate drive UVLO hysteresis			430		mV

- (1) For devices procured in the 8-pin WSON package the R_{DS(on)} limits are specified by design characterization data only.

6.7 Typical Characteristics

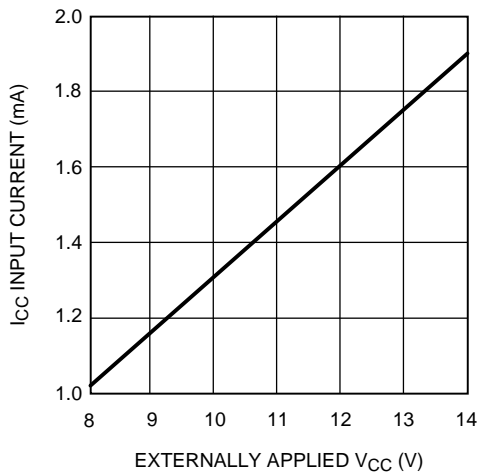

Figure 1. I_{CC} Current vs Applied V_{CC} Voltage

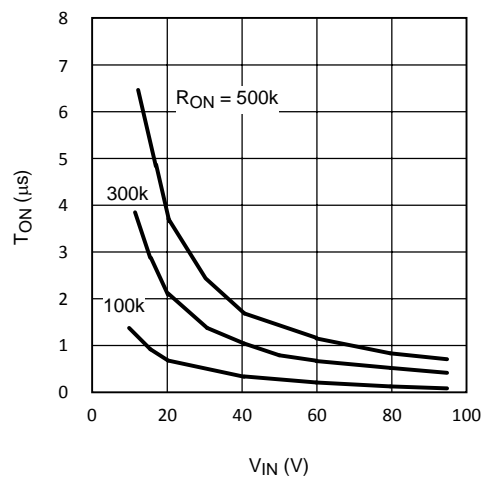

Figure 2. On-Time vs Input Voltage and R_{ON}

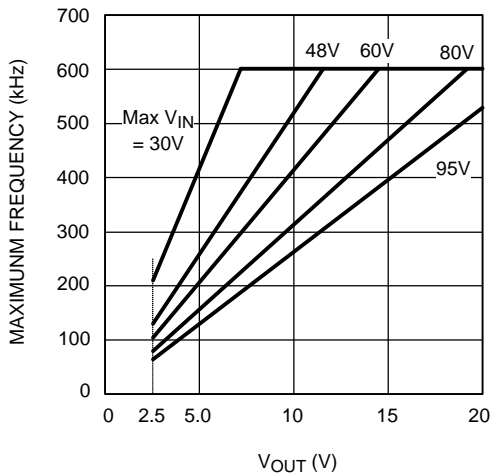

Figure 3. Maximum Frequency vs V_{OUT} and V_{IN}

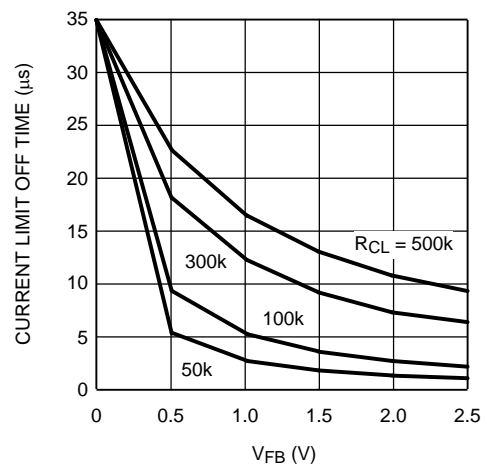

Figure 4. Current Limit Off-Time vs V_{FB} and R_{CL}

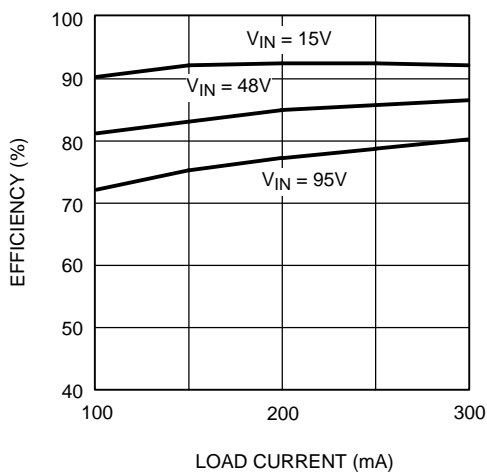

Figure 5. Efficiency vs Load Current vs V_{IN}
(Circuit of Figure 10)

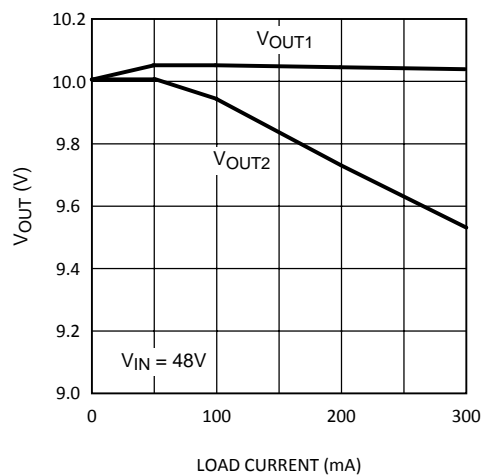

Figure 6. Output Voltage vs Load Current
(Circuit of Figure 10)

7 Detailed Description

7.1 Overview

The LM5008 regulator is an easy-to-use buck DC-DC converter that operates from 9.5-V to 95-V supply voltage. The device is intended for step-down conversions from 12-V, 24-V, and 48-V unregulated, semi-regulated and fully-regulated supply rails. With integrated buck power MOSFET, the LM5008 delivers up to 350-mA DC load current with exceptional efficiency and low input quiescent current in a very small solution size.

Designed for simple implementation, a nearly fixed-frequency, constant on-time (COT) operation with discontinuous conduction mode (DCM) at light loads is ideal for low-noise, high current, fast transient load requirements. Control loop compensation is not required reducing design time and external component count.

The LM5008 incorporates other features for comprehensive system requirements, including VCC undervoltage lockout (UVLO), gate drive undervoltage lockout, maximum duty cycle limiter, intelligent current limit off timer, a precharge switch, and thermal shutdown with automatic recovery. These features enable a flexible and easy-to-use platform for a wide range of applications. The pin arrangement is designed for simple and optimized PCB layout, requiring only a few external components.

7.2 Functional Block Diagram

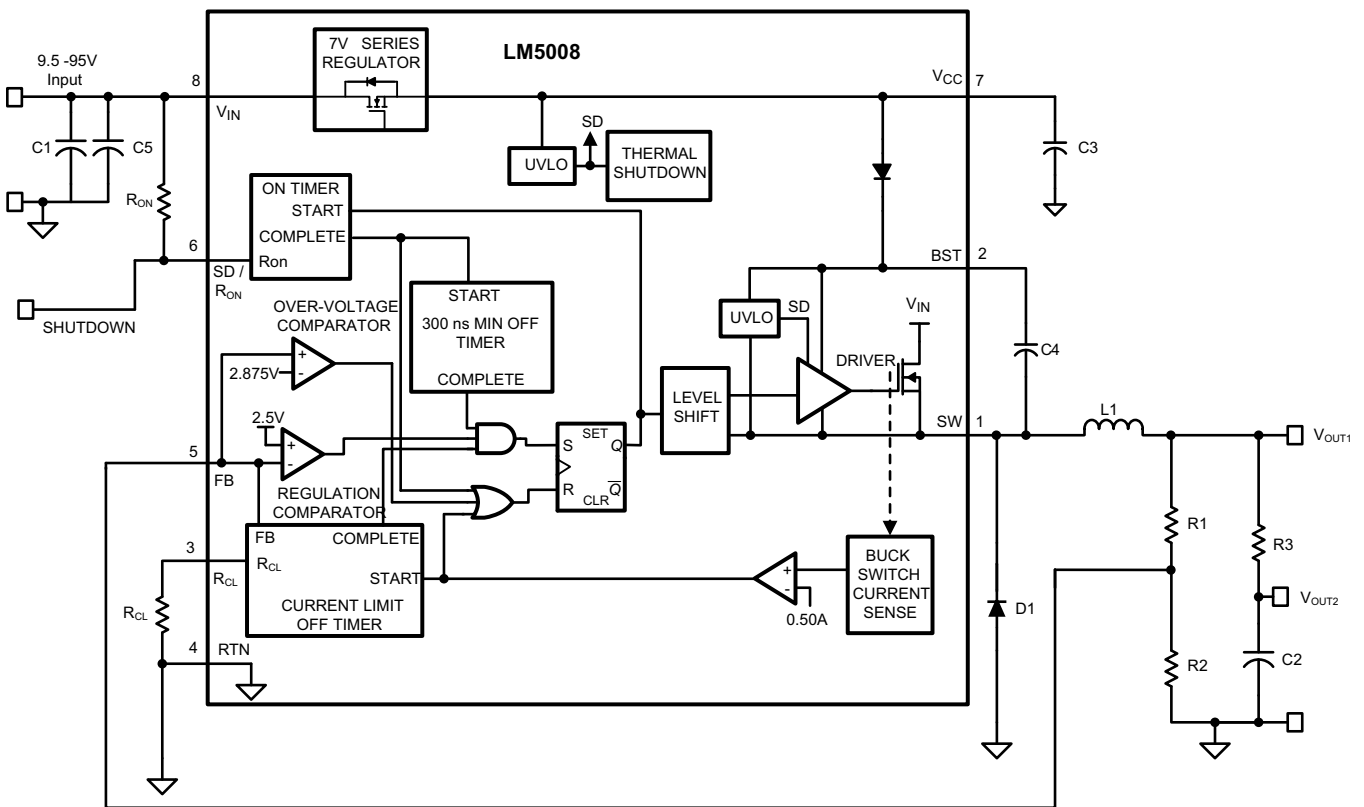

Copyright © 2016, Texas Instruments Incorporated

7.3 Feature Description

7.3.1 Hysteretic Control Circuit Overview

The LM5008 is a buck DC-DC regulator that uses a control scheme in which the on-time varies inversely with line voltage (V_{IN}). Control is based on a comparator and the on-time one-shot, with the output voltage feedback (FB) compared to an internal reference (2.5 V). If the FB level is below the reference the buck switch is turned on for a fixed time determined by the line voltage and a programming resistor (R_{ON}). Following the ON period, the switch remains off for at least the minimum off-timer period of 300 ns. If FB is still below the reference at that time, the switch turns on again for another on-time period. This will continue until regulation is achieved.

The LM5008 operates in discontinuous conduction mode at light load currents, and continuous conduction mode at heavy load current. In discontinuous conduction mode, current through the output inductor starts at zero and ramps up to a peak during the on-time, then ramps back to zero before the end of the off-time. The next on-time period starts when the voltage at FB falls below the internal reference; until then, the inductor current remains zero. In this mode the operating frequency is lower than in continuous conduction mode, and varies with load current. Therefore at light loads the conversion efficiency is maintained, because the switching losses reduce with the reduction in load and frequency. The discontinuous operating frequency can be calculated with Equation 1.

$$F = \frac{V_{OUT}^2 \times L \times 1.28 \times 10^{20}}{R_L \times (R_{ON})^2}$$

where

- R_L = the load resistance (1)

In continuous conduction mode, current flows continuously through the inductor and never ramps down to zero. In this mode the operating frequency is greater than the discontinuous mode frequency and remains relatively constant with load and line variations. The approximate continuous mode operating frequency can be calculated with Equation 2.

$$F = \frac{V_{OUT}}{1.25 \times 10^{-10} \times R_{ON}}$$
(2)

The output voltage (V_{OUT}) can be programmed by two external resistors as shown in *Functional Block Diagram*. The regulation point can be calculated with Equation 3.

$$V_{OUT} = 2.5 \times (R1 + R2) / R2$$
(3)

All hysteretic regulators regulate the output voltage based on ripple voltage at the feedback input, requiring a minimum amount of ESR for the output capacitor C2. A minimum of 25 mV to 50 mV of ripple voltage at the feedback pin (FB) is required for the LM5008. In cases where the capacitor ESR is too small, additional series resistance may be required (R3 in *Functional Block Diagram*).

For applications where lower output voltage ripple is required the output can be taken directly from a low-ESR output capacitor, as shown in Figure 7. However, R3 slightly degrades the load regulation.

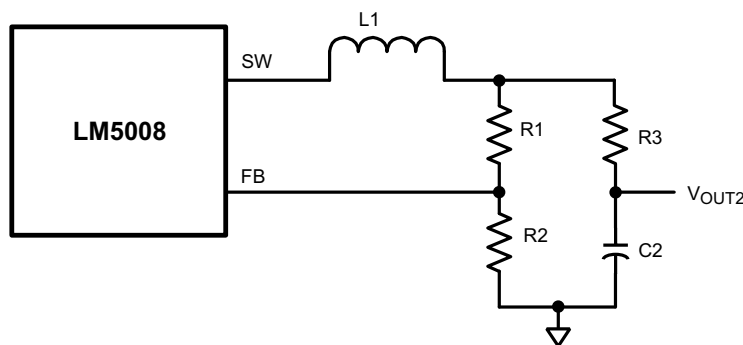

Copyright © 2016, Texas Instruments Incorporated

Figure 7. Low-Ripple Output Configuration

Feature Description (continued)

7.3.2 High Voltage Start-Up Regulator

The LM5008 contains an internal high voltage start-up regulator. The input pin (V_{IN}) can be connected directly to the line voltages up to 95 Volts, with transient capability to 100 V. The regulator is internally current limited to 9.5 mA at V_{CC} . Upon power up, the regulator sources current into the external capacitor at V_{CC} (C3). When the voltage on the V_{CC} pin reaches the undervoltage lockout threshold of 6.3 V, the buck switch is enabled.

In applications involving a high value for V_{IN} , where power dissipation in the V_{CC} regulator is a concern, an auxiliary voltage can be diode connected to the V_{CC} pin. Setting the auxiliary voltage to 8 V to 14 V shuts off the internal regulator, reducing internal power dissipation. See Figure 8. The current required into the V_{CC} pin is shown in Figure 1.

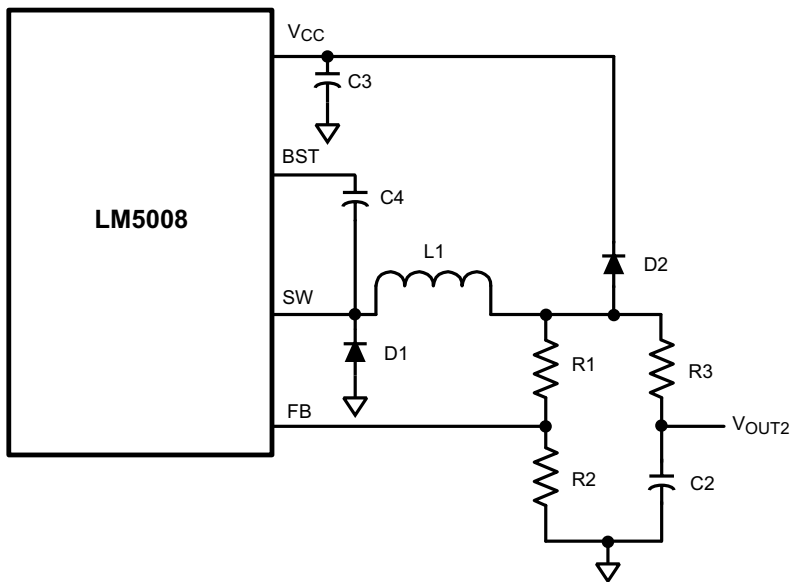

Copyright © 2016, Texas Instruments Incorporated

Figure 8. Self-Biased Configuration

7.3.3 Regulation Comparator

The feedback voltage at FB is compared to an internal 2.5-V reference. In normal operation (the output voltage is regulated), an on-time period is initiated when the voltage at FB falls below 2.5 V. The buck switch stays on for the on-time, causing the FB voltage to rise above 2.5 V. After the on-time period, the buck switch stays off until the FB voltage again falls below 2.5 V. During start-up, the FB voltage is below 2.5 V at the end of each on-time, resulting in the minimum off-time of 300 ns. Bias current at the FB pin is nominally 100 nA.

7.3.4 Overvoltage Comparator

The feedback voltage at FB is compared to an internal 2.875-V reference. If the voltage at FB rises above 2.875 V, the on-time pulse is immediately terminated. This condition can occur if the input voltage, or the output load, change suddenly. The buck switch will not turn on again until the voltage at FB falls below 2.5 V.

7.3.5 On-Time Generator and Shutdown

The on-time for the LM5008 is determined by the R_{ON} resistor, and is inversely proportional to the input voltage (V_{IN}), resulting in a nearly constant frequency as V_{IN} is varied over its range. Equation 4 shows the on-time equation for the LM5008.

$$T_{ON} = 1.25 \times 10^{-10} \times R_{ON} / V_{IN} \quad (4)$$

See Figure 2. R_{ON} should be selected for a minimum on-time (at maximum V_{IN}) greater than 400 ns for proper current limit operation. This requirement limits the maximum frequency for each application, depending on V_{IN} and V_{OUT} . See Figure 3.

Feature Description (continued)

The LM5008 can be remotely disabled by taking the R_{ON}/SD pin to ground. See Figure 9. The voltage at the R_{ON}/SD pin is between 1.5 and 3 volts, depending on V_{IN} and the value of the R_{ON} resistor.

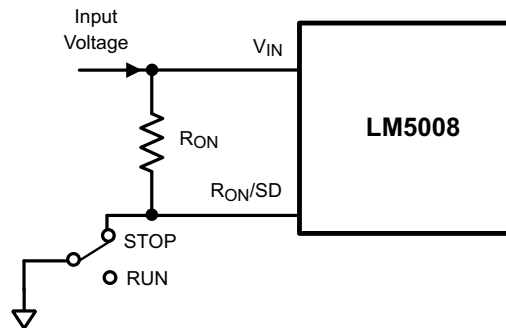

Copyright © 2016, Texas Instruments Incorporated

Figure 9. Shutdown Implementation

7.3.6 Current Limit

The LM5008 contains an intelligent current limit off-timer. If the current in the buck switch exceeds 0.5 A the present cycle is immediately terminated, and a non-resettable off-timer is initiated. The length of off-time is controlled by an external resistor (R_{CL}) and the FB voltage (see Figure 4). When FB = 0 V, a maximum off-time is required, and the time is preset to 35 μs. This condition occurs when the output is shorted, and during the initial part of start-up. This amount of time ensures safe short-circuit operation up to the maximum input voltage of 95 V. In cases of overload where the FB voltage is above zero volts (not a short circuit), the current limit off-time will be less than 35 μs. Reducing the off-time during less severe overloads reduces the amount of foldback, recovery time, and the start-up time. The off-time is calculated from Equation 5.

$$T_{\text{OFF}} = \frac{10^{-5}}{0.285 + \frac{V_{\text{FB}}}{(6.35 \times 10^{-6} \times R_{\text{CL}})}} \quad (5)$$

The current limit sensing circuit is blanked for the first 50-70 ns of each on-time so it is not falsely tripped by the current surge which occurs at turnon. The current surge is required by the re-circulating diode (D1) for its turnoff recovery.

7.3.7 N-Channel Buck Switch and Driver

The LM5008 integrates an N-Channel Buck switch and associated floating high voltage gate driver. The gate driver circuit works in conjunction with an external bootstrap capacitor and an internal high voltage diode. A 0.01-μF ceramic capacitor (C4) connected between the BST pin and SW pin provides the voltage to the driver during the on-time.

During each off-time, the SW pin is at approximately 0 V, and the bootstrap capacitor charges from V_{CC} through the internal diode. The minimum off-timer, set to 300 ns, ensures a minimum time each cycle to recharge the bootstrap capacitor.

An external re-circulating diode (D1) carries the inductor current after the internal Buck switch turns off. This diode must be of the ultra-fast or Schottky type to minimize turnon losses and current overshoot.

7.3.8 Thermal Protection

The LM5008 must be operated so the junction temperature does not exceed 125°C during normal operation. An internal thermal shutdown circuit is provided to protect the LM5008 in the event of a higher than normal junction temperature. When activated, typically at 165°C, the controller is forced into a low power reset state, disabling the buck switch and the V_{CC} regulator. This feature prevents catastrophic failures from accidental device overheating. When the junction temperature reduces below 140°C (typical hysteresis = 25°C), the V_{CC} regulator is enabled, and normal operation is resumed.

7.4 Device Functional Modes

7.4.1 Shutdown Mode

The R^{ON}/SD pin provides ON and OFF control for the LM5008. When V_{SD} is below approximately 0.7 V, the device is in shutdown mode. Both the internal LDO and the switching regulator are off. The quiescent current in shutdown mode drops to 76 μA (typical) at V_{IN} = 48 V. The LM5008 also employs VCC bias rail undervoltage protection. If the V_{CC} bias supply voltage is below its UV threshold, the regulator remains off.

7.4.2 Active Mode

LM5008 is in active mode when the internal bias rail, VCC, is above its UV threshold. Depending on the load current, the device operates in either DCM or CCM mode.

Whenever the load current is reduced to a level less than half the peak-to-peak inductor ripple current, the device enters discontinuous conduction mode (DCM). Calculate the critical conduction boundary using [Equation 6](#).

$$I_{\text{BOUNDARY}} = \frac{\Delta I_L}{2} = \frac{V_{\text{OUT}} \cdot (1-D)}{2 \cdot L_F \cdot F_{\text{SW}}} \quad (6)$$

When the inductor current reaches zero, the SW node becomes high impedance. Resonant ringing occurs at SW as a result of the LC tank circuit formed by the buck inductor and the parasitic capacitance at the SW node. At light loads, several pulses may be skipped in between switching cycles, effectively reducing the switching frequency and further improving light-load efficiency.

8 Application and Implementation

NOTE

Information in the following applications sections is not part of the TI component specification, and TI does not warrant its accuracy or completeness. TI's customers are responsible for determining suitability of components for their purposes. Customers should validate and test their design implementation to confirm system functionality.

8.1 Application Information

The final circuit is shown in [Figure 10](#). The circuit was tested, and the resulting performance is shown in [Figure 12](#) through [Figure 6](#).

8.1.1 Minimum Load Current

A minimum load current of 1 mA is required to maintain proper operation. If the load current falls below that level, the bootstrap capacitor may discharge during the long off-time, and the circuit will either shutdown or cycle on and off at a low frequency. If the load current is expected to drop below 1 mA in the application, the feedback resistors should be chosen low enough in value so they provide the minimum required current at nominal V_{OUT} .

8.2 Typical Application

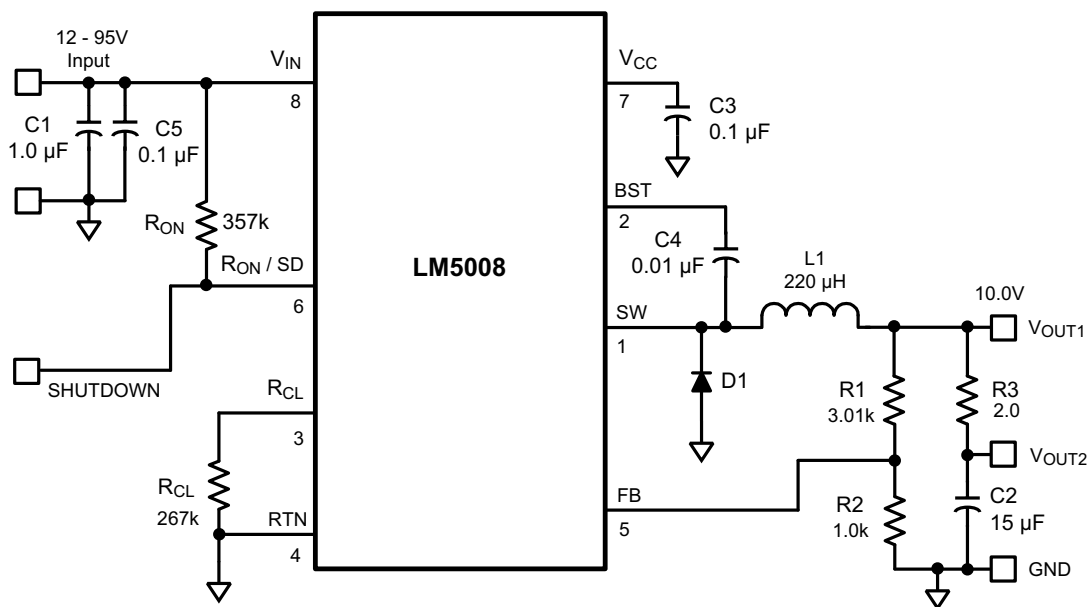

Copyright © 2016, Texas Instruments Incorporated

Figure 10. LM5008 Example Circuit

8.2.1 Design Requirements

A guide for determining the component values will be illustrated with a design example. [Table 1](#) lists the bill of materials for this application. The following steps will configure the LM5008 for:

- Input voltage range (V_{IN}): 12 V to 95 V
- Output voltage (V_{OUT1}): 10 V
- Load current (for continuous conduction mode): 100 mA to 300 mA
- Maximum ripple at V_{OUT2} : 100 mVp-p at maximum input voltage

Typical Application (continued)

Table 1. Bill of Materials (Circuit of Figure 10)

ITEM	DESCRIPTION	PART NUMBER	VALUE
C1	Ceramic Capacitor	TDK C4532X7R2A105M	1 μ F, 100 V
C2	Ceramic Capacitor	TDK C4532X7R1E156M	15 μ F, 25 V
C3	Ceramic Capacitor	Kemet C1206C104K5RAC	0.1 μ F, 50 V
C4	Ceramic Capacitor	Kemet C1206C103K5RAC	0.01 μ F, 50 V
C5	Ceramic Capacitor	TDK C3216X7R2A104M	0.1 μ F, 100 V
D1	Ultra-Fast Power Diode	ON Semi MURA110T3	100 V, 1 A
L1	Power Inductor	Coilcraft DO3316-224 or	220 μ H
		TDK SLF10145T-221MR65	
R1	Resistor	Vishay CRCW12063011F	3.01 k Ω
R2	Resistor	Vishay CRCW12061001F	1 k Ω
R3	Resistor	Vishay CRCW12062R00F	2 Ω
R _{ON}	Resistor	Vishay CRCW12063573F	357 k Ω
R _{CL}	Resistor	Vishay CRCW12062673F	267 k Ω
U1	Switching Regulator	Texas Instruments LM5008	

8.2.2 Detailed Design Procedure

8.2.2.1 Custom Design With WEBENCH® Tools

[Click here](#) to create a custom design using the LM5008 device with the WEBENCH® Power Designer.

1. Start by entering the input voltage (V_{IN}), output voltage (V_{OUT}), and output current (I_{OUT}) requirements.
2. Optimize the design for key parameters such as efficiency, footprint, and cost using the optimizer dial.
3. Compare the generated design with other possible solutions from Texas Instruments.

The WEBENCH Power Designer provides a customized schematic along with a list of materials with real-time pricing and component availability.

In most cases, these actions are available:

- Run electrical simulations to see important waveforms and circuit performance
- Run thermal simulations to understand board thermal performance
- Export customized schematic and layout into popular CAD formats
- Print PDF reports for the design, and share the design with colleagues

Get more information about WEBENCH tools at www.ti.com/WEBENCH.

R1 and R2: From *Functional Block Diagram*, $V_{OUT1} = V_{FB} \times (R1 + R2) / R2$, and because $V_{FB} = 2.5$ V, the ratio of R1 to R2 calculates as 3:1. Standard values of 3.01 k Ω (R1) and 1.00 k Ω (R2) are chosen. Other values could be used as long as the 3:1 ratio is maintained. The selected values, however, provide a small amount of output loading (2.5 mA) in the event the main load is disconnected. This allows the circuit to maintain regulation until the main load is reconnected.

F_s and R_{ON}: The recommended operating frequency range for the LM5008 is 50 kHz to 600 kHz. Unless the application requires a specific frequency, the choice of frequency is generally a compromise because it affects the size of L1 and C2, and the switching losses. The maximum allowed frequency, based on a minimum on-time of 400 ns, is calculated from [Equation 7](#):

$$F_{MAX} = V_{OUT} / (V_{INMAX} \times 400 \text{ ns}) \quad (7)$$

For this exercise, $F_{MAX} = 263$ kHz. From [Equation 2](#), R_{ON} calculates to 304 k Ω . A standard value 357-k Ω resistor is used to allow for tolerances in [Equation 2](#), resulting in a frequency of 224 kHz.

L1: The main parameter affected by the inductor is the output current ripple amplitude. The choice of inductor value therefore depends on both the minimum and maximum load currents, keeping in mind that the maximum ripple current occurs at maximum V_{IN} .

- a. **Minimum load current:** To maintain continuous conduction at minimum I_o (100 mA), the ripple amplitude

(I_{OR}) must be less than 200 mAp-p so the lower peak of the waveform does not reach zero. L1 is calculated using [Equation 8](#).

$$L1 = \frac{V_{OUT1} \times (V_{IN} - V_{OUT1})}{I_{OR} \times F_s \times V_{IN}} \quad (8)$$

At $V_{IN} = 95$ V, L1 (minimum) calculates to 200 μ H. The next larger standard value (220 μ H) is chosen and with this value I_{OR} calculates to 181 mAp-p at $V_{IN} = 95$ V, and 34 mAp-p at $V_{IN} = 12$ V.

- b. **Maximum load current:** At a load current of 300 mA, the peak of the ripple waveform must not reach the minimum value of the LM5008's current limit threshold (410 mA). Therefore the ripple amplitude must be less than 220 mAp-p, which is already satisfied in [Equation 8](#). With $L1 = 220$ μ H, at maximum V_{IN} and I_O , the peak of the ripple will be 391 mA. While L1 must carry this peak current without saturating or exceeding its temperature rating, it also must be capable of carrying the maximum value of the LM5008's current limit threshold (610 mA) without saturating, because the current limit is reached during start-up.

The DC resistance of the inductor should be as low as possible. For example, if the inductor's DCR is 1 Ω , the power dissipated at maximum load current is 0.09 W. While small, it is not insignificant compared to the load power of 3 W.

C3: The capacitor on the V_{CC} output provides not only noise filtering and stability, but its primary purpose is to prevent false triggering of the V_{CC} UVLO at the buck switch ON/OFF transitions. For this reason, C3 should be no smaller than 0.1 μ F.

C2, and R3: When selecting the output filter capacitor C2, the items to consider are ripple voltage due to its ESR, ripple voltage due to its capacitance, and the nature of the load.

- a. **ESR and R3:** A low ESR for C2 is generally desirable so as to minimize power losses and heating within the capacitor. However, a hysteretic regulator requires a minimum amount of ripple voltage at the feedback input for proper loop operation. For the LM5008 the minimum ripple required at pin 5 is 25 mVp-p, requiring a minimum ripple at V_{OUT1} of 100 mV. Because the minimum ripple current (at minimum V_{IN}) is 34 mAp-p, the minimum ESR required at V_{OUT1} is 100 mV / 34 mA = 2.94 Ω . Because quality capacitors for SMPS applications have an ESR considerably less than this, R3 is inserted as shown in [Functional Block Diagram](#). R3's value, along with C2's ESR, must result in at least 25 mVp-p ripple at pin 5. Generally, R3 will be 0.5 to 3 Ω .
- b. **Nature of the Load:** The load can be connected to V_{OUT1} or V_{OUT2} . V_{OUT1} provides good regulation, but with a ripple voltage which ranges from 100 mV (at $V_{IN} = 12$ V) to 500 mV (at $V_{IN} = 95$ V). Alternatively, V_{OUT2} provides low ripple, but lower regulation due to R3.

For a maximum allowed ripple voltage of 100 mVp-p at V_{OUT2} (at $V_{IN} = 95$ V), assume an ESR of 0.4 Ω for C2. At maximum V_{IN} , the ripple current is 181 mAp-p, creating a ripple voltage of 72 mVp-p. This leaves 28 mVp-p of ripple due to the capacitance. The average current into C2 due to the ripple current is calculated using the waveform in [Figure 11](#).

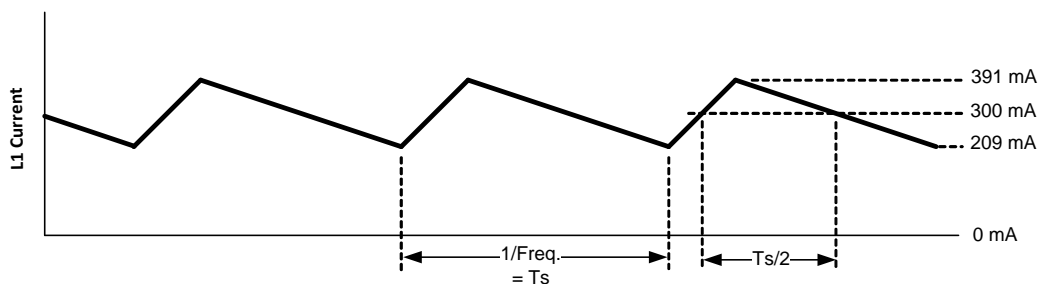

Figure 11. Inductor Current Waveform

Starting when the current reaches I_O (300 mA in [Figure 11](#)) half way through the on-time, the current continues to increase to the peak (391 mA), and then decreases to 300 mA half way through the off-time. The average value of this portion of the waveform is 45.5 mA, and will cause half of the voltage ripple, or 14 mV. The interval is one half of the frequency cycle time, or 2.23 μ s. Using the capacitor's basic equation (see [Equation 9](#)), the minimum value for C2 is 7.2 μ F.

The ripple due to C2's capacitance is 90° out of phase from the ESR ripple, and the two numbers do not add directly. However, this calculation provides a practical minimum value for C2 based on its ESR and the target spec. To allow for the capacitor's tolerance, temperature effects, and voltage effects, a 15-μF, X7R capacitor is used.

- c. **In summary:** The above calculations provide a minimum value for C2 and a calculation for R3. The ESR is just as important as the capacitance. The calculated values are guidelines, and should be treated as starting points. For each application, experimentation is needed to determine the optimum values for R3 and C2.

$$C = I \times \Delta t / \Delta V \quad (9)$$

R_{CL}: When a current limit condition is detected, the minimum off-time set by this resistor must be greater than the maximum normal off-time which occurs at maximum V_{IN}. Using [Equation 4](#), the minimum on-time is 0.47 μs, yielding a maximum off-time of 3.99 μs. This is increased by 117 ns (to 4.11 μs) due to a ±25% tolerance of the on-time. This value is then increased to allow for:

The response time of the current limit detection loop (400 ns).

The off-time determined by [Equation 5](#) has a ±25% tolerance.

$$t_{\text{OFFCL(MIN)}} = (4.11 \mu\text{s} + 0.40 \mu\text{s}) \times 1.25 = 5.64 \mu\text{s} \quad (10)$$

Using [Equation 5](#), R_{CL} calculates to 264 kΩ (at V_{FB} = 2.5 V). The closest standard value is 267 kΩ.

D1: The important parameters are reverse recovery time and forward voltage. The reverse recovery time determines how long the reverse current surge lasts each time the buck switch is turned on. The forward voltage drop is significant in the event the output is short-circuited as it is only this diode's voltage which forces the inductor current to reduce during the forced off-time. For this reason, a higher voltage is better, although that affects efficiency. A good choice is an ultra-fast power diode, such as the MURA110T3 from ON Semiconductor. Its reverse recovery time is 30 ns, and its forward voltage drop is approximately 0.72 V at 300 mA at 25°C. Other types of diodes may have a lower forward voltage drop, but may have longer recovery times, or greater reverse leakage. D1's reverse voltage rating must be at least as great as the maximum V_{IN}, and its current rating be greater than the maximum current limit threshold (610 mA).

C1: This capacitor's purpose is to supply most of the switch current during the on-time, and limit the voltage ripple at V_{IN}, on the assumption that the voltage source feeding V_{IN} has an output impedance greater than zero. At maximum load current when the buck switch turns on, the current into pin 8 will suddenly increase to the lower peak of the output current waveform, ramp up to the peak value, then drop to zero at turnoff. The average input current during this on-time is the load current (300 mA). For a worst case calculation, C1 must supply this average load current during the maximum on-time. To keep the input voltage ripple to less than 2 V (for this exercise), C1 is calculated with [Equation 11](#).

$$C1 = \frac{I \times t_{\text{ON}}}{\Delta V} = \frac{0.3\text{A} \times 3.72 \mu\text{s}}{2.0\text{V}} = 0.56 \mu\text{F} \quad (11)$$

Quality ceramic capacitors in this value have a low ESR which adds only a few millivolts to the ripple. It is the capacitance which is dominant in this case. To allow for the capacitor's tolerance, temperature effects, and voltage effects, a 1.0-μF, 100-V, X7R capacitor will be used.

C4: The recommended value is 0.01 μF for C4, as this is appropriate in the majority of applications. A high-quality ceramic capacitor, with low ESR is recommended as C4 supplies the surge current to charge the buck switch gate at turnon. A low ESR also ensures a quick recharge during each off-time. At minimum V_{IN}, when the on-time is at maximum, it is possible during start-up that C4 will not fully recharge during each 300-ns off-time. The circuit will not be able to complete the start-up, and achieve output regulation. This can occur when the frequency is intended to be low (for example, R_{ON} = 500 K). In this case C4 should be increased so it can maintain sufficient voltage across the buck switch driver during each on-time.

C5: This capacitor helps avoid supply voltage transients and ringing due to long lead inductance at V_{IN}. A low-ESR, 0.1-μF ceramic chip capacitor is recommended, placed close to the LM5008.

8.2.3 Application Curves

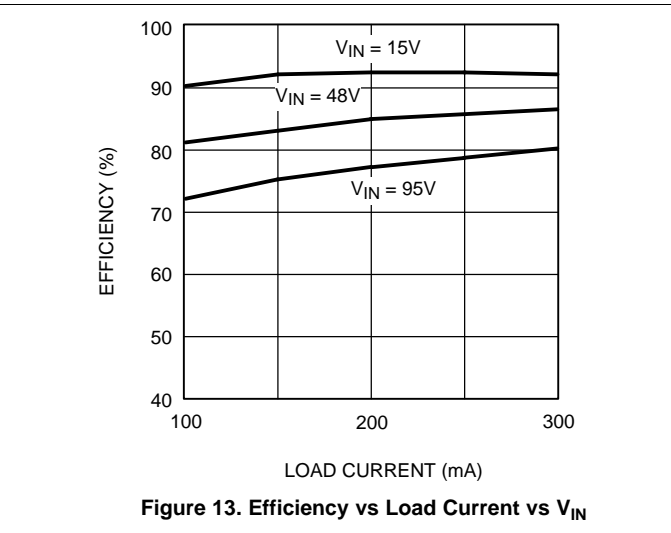
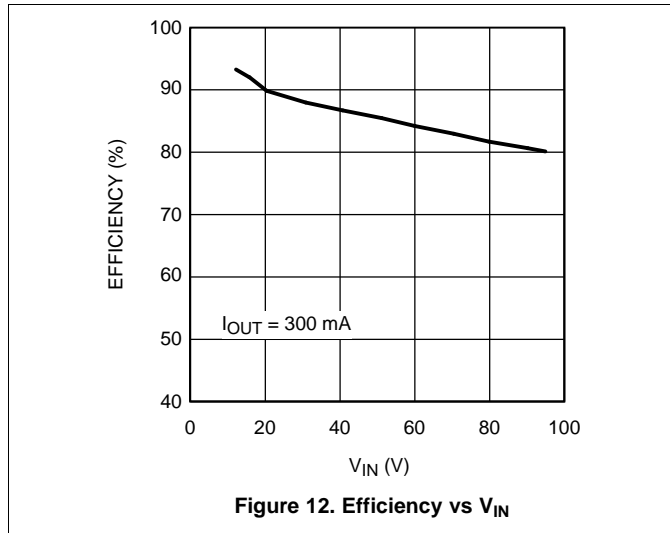

9 Power Supply Recommendations

The LM5008 converter is designed to operate from a wide input voltage range from 9.5 V to 95 V. The characteristics of the input supply must be compatible with the [Absolute Maximum Ratings](#) and [Recommended Operating Conditions](#). In addition, the input supply must be capable of delivering the required input current to the fully-loaded regulator. Estimate the average input current with [Equation 12](#).

$$I_{IN} = \frac{V_{OUT} \cdot I_{OUT}}{V_{IN} \cdot \eta}$$

where

- η is the efficiency (12)

If the converter is connected to an input supply through long wires or PCB traces with large impedance, achieving stable performance requires special care. The parasitic inductance and resistance of the input cables may have an adverse affect on converter operation. The parasitic inductance in combination with the low-ESR ceramic input capacitors form an underdamped resonant circuit. This circuit can cause overvoltage transients at V_{IN} each time the input supply is cycled ON and OFF. The parasitic resistance causes the input voltage to dip during a load transient. If the regulator is operating close to the minimum input voltage, this dip can cause false UVLO fault triggering and a system reset. The best way to solve such issues is to reduce the distance from the input supply to the regulator and use an aluminum or tantalum input capacitor in parallel with the ceramics. The moderate ESR of the electrolytic capacitors helps to damp the input resonant circuit and reduce any voltage overshoots. A capacitance in the range of 10 μF to 47 μF is usually sufficient to provide input damping and helps to hold the input voltage steady during large load transients.

An EMI input filter is often used in front of the regulator that, unless carefully designed, can lead to instability as well as some of the effects mentioned above. The user's guide [Simple Success with Conducted EMI for DC-DC Converters](#) (SNVA489) provides helpful suggestions when designing an input filter for any switching regulator.

10 Layout

10.1 Layout Guidelines

The LM5008 regulation and overvoltage comparators are very fast, and as such responds to short-duration noise pulses. Layout considerations are therefore critical for optimum performance:

1. Minimize the area of the high di/dt switching current loop consisting of the VIN pin, input ceramic capacitor, SW node and freewheeling power diode. Keep the input capacitor as close as possible to the VIN pin and route a short, direct connection to the RTN pin using polygon copper pours.
2. Minimize SW copper area to reduce radiated noise related to high dv/dt.
3. Locate all components as physically close as possible to their respective pins, thereby minimizing noise pickup in the printed-circuit tracks.
4. Locate the FB trace away from noise sources and inductors. Place the resistor close to the FB pin to minimize the length of the FB trace.

If the internal dissipation of the LM5008 converter produces excessive junction temperatures during normal operation, optimal use of the PCB ground plane can help considerably to dissipate heat. The exposed pad on the bottom of the WSON-8 package can be soldered to a ground plane on the PCB, and that plane should extend out from beneath the IC to help dissipate the heat. Additionally, the use of wide PCB traces for power connection can also help conduct heat away from the IC. Judicious positioning of the LM5008 converter within the end product, along with use of any available air flow (forced or natural convection), can help reduce the operating junction temperature.

10.2 Layout Examples

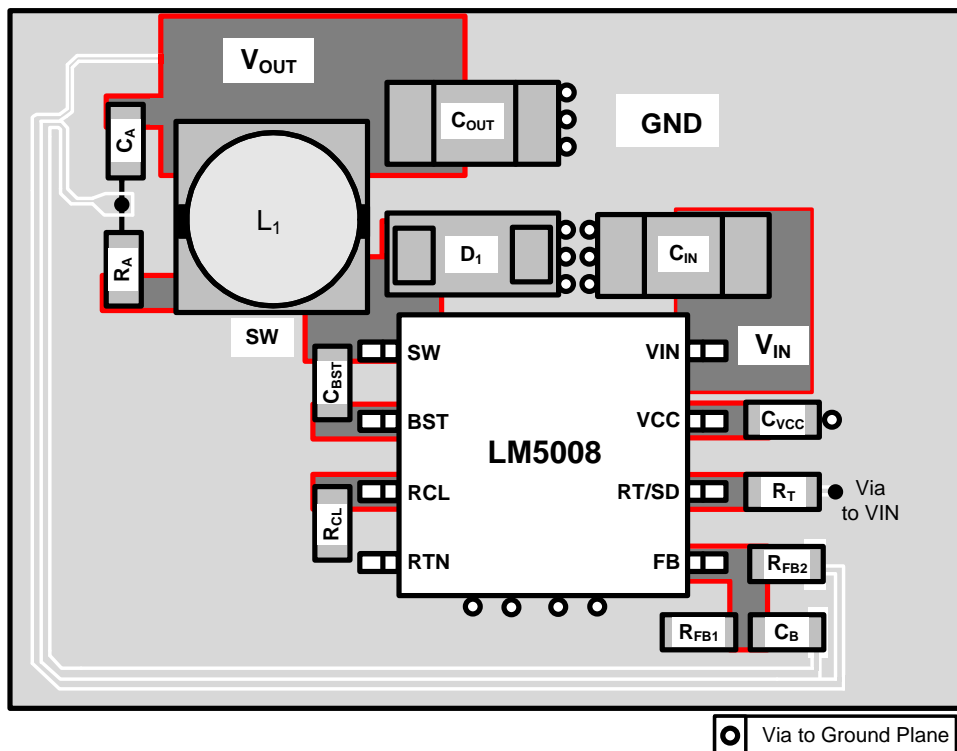

Figure 14. LM5008 Evaluation Board Top Layer

11 Device and Documentation Support

11.1 Device Support

11.1.1 Third-Party Products Disclaimer

TI'S PUBLICATION OF INFORMATION REGARDING THIRD-PARTY PRODUCTS OR SERVICES DOES NOT CONSTITUTE AN ENDORSEMENT REGARDING THE SUITABILITY OF SUCH PRODUCTS OR SERVICES OR A WARRANTY, REPRESENTATION OR ENDORSEMENT OF SUCH PRODUCTS OR SERVICES, EITHER ALONE OR IN COMBINATION WITH ANY TI PRODUCT OR SERVICE.

11.1.2 Custom Design With WEBENCH® Tools

[Click here](#) to create a custom design using the LM5008 device with the WEBENCH® Power Designer.

1. Start by entering the input voltage (V_{IN}), output voltage (V_{OUT}), and output current (I_{OUT}) requirements.
2. Optimize the design for key parameters such as efficiency, footprint, and cost using the optimizer dial.
3. Compare the generated design with other possible solutions from Texas Instruments.

The WEBENCH Power Designer provides a customized schematic along with a list of materials with real-time pricing and component availability.

In most cases, these actions are available:

- Run electrical simulations to see important waveforms and circuit performance
- Run thermal simulations to understand board thermal performance
- Export customized schematic and layout into popular CAD formats
- Print PDF reports for the design, and share the design with colleagues

Get more information about WEBENCH tools at www.ti.com/WEBENCH.

11.1.3 Development Support

For development support see the following:

- For TI's reference design library, visit [TI Designs](#)
- For TI's WEBENCH Design Environments, visit [WEBENCH® Design Center](#)

11.2 Documentation Support

11.2.1 Related Documentation

For related documentation see the following:

- [LM5008 Quick-start Calculator](#)
- [AN-1330 LM5008 Evaluation Board](#) (SNVA380)
- [AN-1925 LM5008A Evaluation Board](#) (SNVA380)
- [Buck Regulator Topologies for Wide Input/Output Voltage Differentials](#) (SNVA594)

11.2.1.1 PCB Layout Resources

- [AN-1149 Layout Guidelines for Switching Power Supplies](#) (SNVA021)
- [AN-1229 Simple Switcher PCB Layout Guidelines](#) (SNVA054)
- [Constructing Your Power Supply – Layout Considerations](#) (SLUP230)
- [Low Radiated EMI Layout Made SIMPLE with LM4360x and LM4600x](#) (SNVA721)
- [AN-2162 Simple Success With Conducted EMI From DC-DC Converters](#) (SNVA489)
- [Reduce Buck-Converter EMI and Voltage Stress by Minimizing Inductive Parasitics](#) (SLYT682)
- White Papers:
 - [Valuing Wide \$V_{IN}\$, Low EMI Synchronous Buck Circuits for Cost-driven, Demanding Applications](#)
 - [An Overview of Conducted EMI Specifications for Power Supplies](#)
 - [An Overview of Radiated EMI Specifications for Power Supplies](#)

Documentation Support (continued)

11.2.1.2 Thermal Design Resources

- [AN-2020 Thermal Design By Insight, Not Hindsight](#) (SNVA419)
- [AN-1520 A Guide to Board Layout for Best Thermal Resistance for Exposed Pad Packages](#) (SNVA183)
- [Semiconductor and IC Package Thermal Metrics](#) (SPRA953)
- [Thermal Design Made Simple with LM43603 and LM43602](#) (SNVA719)
- [PowerPAD™ Thermally Enhanced Package](#) (SLMA002)
- [PowerPAD Made Easy](#) (SLMA004)
- [Using New Thermal Metrics](#) (SBVA025)
- Power House Blogs:
 - [High-Density PCB Layout of DC/DC Converters](#)

11.3 Receiving Notification of Documentation Updates

To receive notification of documentation updates, navigate to the device product folder on ti.com. In the upper right corner, click on *Alert me* to register and receive a weekly digest of any product information that has changed. For change details, review the revision history included in any revised document.

11.4 Community Resources

The following links connect to TI community resources. Linked contents are provided "AS IS" by the respective contributors. They do not constitute TI specifications and do not necessarily reflect TI's views; see TI's [Terms of Use](#).

TI E2E™ Online Community *TI's Engineer-to-Engineer (E2E) Community*. Created to foster collaboration among engineers. At e2e.ti.com, you can ask questions, share knowledge, explore ideas and help solve problems with fellow engineers.

Design Support *TI's Design Support* Quickly find helpful E2E forums along with design support tools and contact information for technical support.

11.5 Trademarks

PowerPAD, E2E are trademarks of Texas Instruments.
WEBENCH is a registered trademark of Texas Instruments.
All other trademarks are the property of their respective owners.

11.6 Electrostatic Discharge Caution



These devices have limited built-in ESD protection. The leads should be shorted together or the device placed in conductive foam during storage or handling to prevent electrostatic damage to the MOS gates.

11.7 Glossary

[SLYZ022](#) — *TI Glossary*.

This glossary lists and explains terms, acronyms, and definitions.

12 Mechanical, Packaging, and Orderable Information

The following pages include mechanical, packaging, and orderable information. This information is the most current data available for the designated devices. This data is subject to change without notice and revision of this document. For browser-based versions of this data sheet, refer to the left-hand navigation.

PACKAGING INFORMATION

Orderable Device	Status (1)	Package Type	Package Drawing	Pins	Package Qty	Eco Plan (2)	Lead finish/ Ball material (6)	MSL Peak Temp (3)	Op Temp (°C)	Device Marking (4/5)	Samples
LM5008MM	LIFEBUY	VSSOP	DGK	8	1000	Non-RoHS & Green	Call TI	Level-1-260C-UNLIM	-40 to 125	SAYB	
LM5008MM/NOPB	ACTIVE	VSSOP	DGK	8	1000	RoHS & Green	SN	Level-1-260C-UNLIM	-40 to 125	SAYB	Samples
LM5008MMX	LIFEBUY	VSSOP	DGK	8	3500	Non-RoHS & Green	Call TI	Level-1-260C-UNLIM	-40 to 125	SAYB	
LM5008MMX/NOPB	ACTIVE	VSSOP	DGK	8	3500	RoHS & Green	SN	Level-1-260C-UNLIM	-40 to 125	SAYB	Samples
LM5008SD	LIFEBUY	WSON	NGU	8	1000	Non-RoHS & Green	Call TI	Level-1-260C-UNLIM		L00040B	
LM5008SDC/NOPB	ACTIVE	WSON	NGU	8	1000	RoHS & Green	NIPDAU SN	Level-1-260C-UNLIM	-40 to 125	L5008SD	Samples
LM5008SDCX/NOPB	ACTIVE	WSON	NGU	8	4500	RoHS & Green	NIPDAU SN	Level-1-260C-UNLIM	-40 to 125	L5008SD	Samples

(1) The marketing status values are defined as follows:

ACTIVE: Product device recommended for new designs.

LIFEBUY: TI has announced that the device will be discontinued, and a lifetime-buy period is in effect.

NRND: Not recommended for new designs. Device is in production to support existing customers, but TI does not recommend using this part in a new design.

PREVIEW: Device has been announced but is not in production. Samples may or may not be available.

OBSOLETE: TI has discontinued the production of the device.

(2) **RoHS:** TI defines "RoHS" to mean semiconductor products that are compliant with the current EU RoHS requirements for all 10 RoHS substances, including the requirement that RoHS substance do not exceed 0.1% by weight in homogeneous materials. Where designed to be soldered at high temperatures, "RoHS" products are suitable for use in specified lead-free processes. TI may reference these types of products as "Pb-Free".

RoHS Exempt: TI defines "RoHS Exempt" to mean products that contain lead but are compliant with EU RoHS pursuant to a specific EU RoHS exemption.

Green: TI defines "Green" to mean the content of Chlorine (Cl) and Bromine (Br) based flame retardants meet JS709B low halogen requirements of <=1000ppm threshold. Antimony trioxide based flame retardants must also meet the <=1000ppm threshold requirement.

(3) MSL, Peak Temp. - The Moisture Sensitivity Level rating according to the JEDEC industry standard classifications, and peak solder temperature.

(4) There may be additional marking, which relates to the logo, the lot trace code information, or the environmental category on the device.

(5) Multiple Device Markings will be inside parentheses. Only one Device Marking contained in parentheses and separated by a "~" will appear on a device. If a line is indented then it is a continuation of the previous line and the two combined represent the entire Device Marking for that device.

⁽⁶⁾ Lead finish/Ball material - Orderable Devices may have multiple material finish options. Finish options are separated by a vertical ruled line. Lead finish/Ball material values may wrap to two lines if the finish value exceeds the maximum column width.

Important Information and Disclaimer:The information provided on this page represents TI's knowledge and belief as of the date that it is provided. TI bases its knowledge and belief on information provided by third parties, and makes no representation or warranty as to the accuracy of such information. Efforts are underway to better integrate information from third parties. TI has taken and continues to take reasonable steps to provide representative and accurate information but may not have conducted destructive testing or chemical analysis on incoming materials and chemicals. TI and TI suppliers consider certain information to be proprietary, and thus CAS numbers and other limited information may not be available for release.

In no event shall TI's liability arising out of such information exceed the total purchase price of the TI part(s) at issue in this document sold by TI to Customer on an annual basis.

TAPE AND REEL INFORMATION

QUADRANT ASSIGNMENTS FOR PIN 1 ORIENTATION IN TAPE

*All dimensions are nominal

Device	Package Type	Package Drawing	Pins	SPQ	Reel Diameter (mm)	Reel Width W1 (mm)	A0 (mm)	B0 (mm)	K0 (mm)	P1 (mm)	W (mm)	Pin1 Quadrant
LM5008MM	VSSOP	DGK	8	1000	178.0	12.4	5.3	3.4	1.4	8.0	12.0	Q1
LM5008MM/NOPB	VSSOP	DGK	8	1000	330.0	12.4	5.3	3.4	1.4	8.0	12.0	Q1
LM5008MM/NOPB	VSSOP	DGK	8	1000	178.0	12.4	5.3	3.4	1.4	8.0	12.0	Q1
LM5008MMX	VSSOP	DGK	8	3500	330.0	12.4	5.3	3.4	1.4	8.0	12.0	Q1
LM5008MMX/NOPB	VSSOP	DGK	8	3500	330.0	12.4	5.3	3.4	1.4	8.0	12.0	Q1
LM5008SD	WSOP	NGU	8	1000	178.0	12.4	4.3	4.3	1.3	8.0	12.0	Q1
LM5008SDC/NOPB	WSOP	NGU	8	1000	178.0	12.4	4.3	4.3	1.3	8.0	12.0	Q1
LM5008SDCX/NOPB	WSOP	NGU	8	4500	330.0	12.4	4.3	4.3	1.1	8.0	12.0	Q1
LM5008SDCX/NOPB	WSOP	NGU	8	4500	330.0	12.4	4.3	4.3	1.3	8.0	12.0	Q1

TAPE AND REEL BOX DIMENSIONS

*All dimensions are nominal

Device	Package Type	Package Drawing	Pins	SPQ	Length (mm)	Width (mm)	Height (mm)
LM5008MM	VSSOP	DGK	8	1000	208.0	191.0	35.0
LM5008MM/NOPB	VSSOP	DGK	8	1000	366.0	364.0	50.0
LM5008MM/NOPB	VSSOP	DGK	8	1000	208.0	191.0	35.0
LM5008MMX	VSSOP	DGK	8	3500	367.0	367.0	35.0
LM5008MMX/NOPB	VSSOP	DGK	8	3500	367.0	367.0	35.0
LM5008SD	WSON	NGU	8	1000	208.0	191.0	35.0
LM5008SDC/NOPB	WSON	NGU	8	1000	208.0	191.0	35.0
LM5008SDCX/NOPB	WSON	NGU	8	4500	346.0	346.0	35.0
LM5008SDCX/NOPB	WSON	NGU	8	4500	367.0	367.0	35.0

DGK0008A



PACKAGE OUTLINE

VSSOP - 1.1 mm max height

SMALL OUTLINE PACKAGE



NOTES:

PowerPAD is a trademark of Texas Instruments.

1. All linear dimensions are in millimeters. Any dimensions in parenthesis are for reference only. Dimensioning and tolerancing per ASME Y14.5M.
2. This drawing is subject to change without notice.
3. This dimension does not include mold flash, protrusions, or gate burrs. Mold flash, protrusions, or gate burrs shall not exceed 0.15 mm per side.
4. This dimension does not include interlead flash. Interlead flash shall not exceed 0.25 mm per side.
5. Reference JEDEC registration MO-187.

EXAMPLE BOARD LAYOUT

DGK0008A

™ VSSOP - 1.1 mm max height

SMALL OUTLINE PACKAGE



LAND PATTERN EXAMPLE
EXPOSED METAL SHOWN
SCALE: 15X



SOLDER MASK DETAILS

4214862/A 04/2023

NOTES: (continued)

6. Publication IPC-7351 may have alternate designs.
7. Solder mask tolerances between and around signal pads can vary based on board fabrication site.
8. Vias are optional depending on application, refer to device data sheet. If any vias are implemented, refer to their locations shown on this view. It is recommended that vias under paste be filled, plugged or tented.
9. Size of metal pad may vary due to creepage requirement.

EXAMPLE STENCIL DESIGN

DGK0008A

™ VSSOP - 1.1 mm max height

SMALL OUTLINE PACKAGE



SOLDER PASTE EXAMPLE
SCALE: 15X

4214862/A 04/2023

NOTES: (continued)

11. Laser cutting apertures with trapezoidal walls and rounded corners may offer better paste release. IPC-7525 may have alternate design recommendations.
12. Board assembly site may have different recommendations for stencil design.

EXAMPLE STENCIL DESIGN

NGU0008B

WSON - 0.8 mm max height

PLASTIC SMALL OUTLINE - NO LEAD

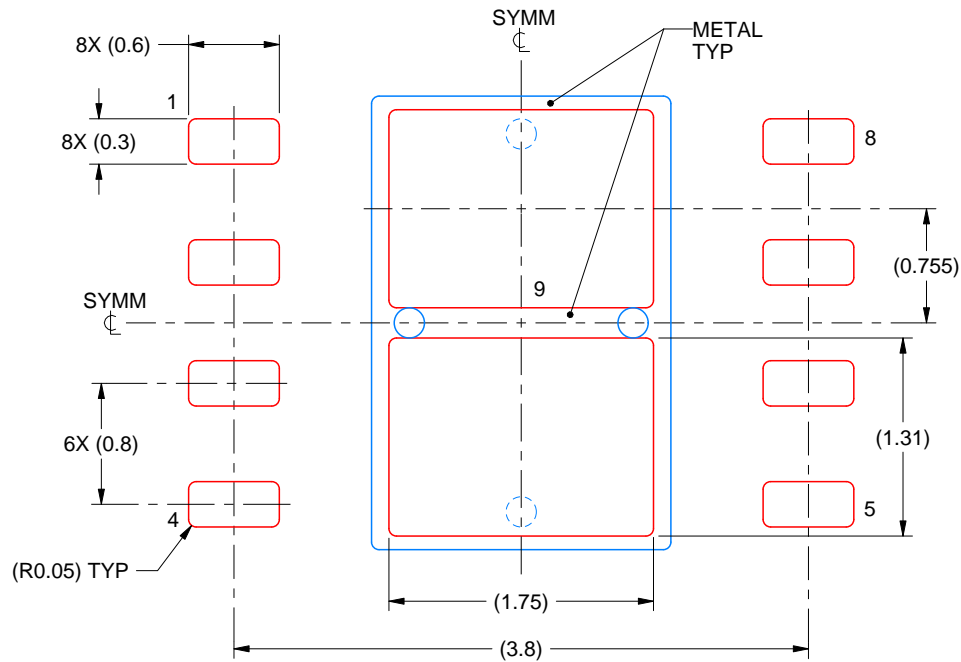

SOLDER PASTE EXAMPLE
BASED ON 0.125 mm THICK STENCIL

EXPOSED PAD 9:
77% PRINTED SOLDER COVERAGE BY AREA UNDER PACKAGE
SCALE:20X

4214936/A 12/2023

NOTES: (continued)

6. Laser cutting apertures with trapezoidal walls and rounded corners may offer better paste release. IPC-7525 may have alternate design recommendations.

IMPORTANT NOTICE AND DISCLAIMER

TI PROVIDES TECHNICAL AND RELIABILITY DATA (INCLUDING DATA SHEETS), DESIGN RESOURCES (INCLUDING REFERENCE DESIGNS), APPLICATION OR OTHER DESIGN ADVICE, WEB TOOLS, SAFETY INFORMATION, AND OTHER RESOURCES "AS IS" AND WITH ALL FAULTS, AND DISCLAIMS ALL WARRANTIES, EXPRESS AND IMPLIED, INCLUDING WITHOUT LIMITATION ANY IMPLIED WARRANTIES OF MERCHANTABILITY, FITNESS FOR A PARTICULAR PURPOSE OR NON-INFRINGEMENT OF THIRD PARTY INTELLECTUAL PROPERTY RIGHTS.

These resources are intended for skilled developers designing with TI products. You are solely responsible for (1) selecting the appropriate TI products for your application, (2) designing, validating and testing your application, and (3) ensuring your application meets applicable standards, and any other safety, security, regulatory or other requirements.

These resources are subject to change without notice. TI grants you permission to use these resources only for development of an application that uses the TI products described in the resource. Other reproduction and display of these resources is prohibited. No license is granted to any other TI intellectual property right or to any third party intellectual property right. TI disclaims responsibility for, and you will fully indemnify TI and its representatives against, any claims, damages, costs, losses, and liabilities arising out of your use of these resources.

TI's products are provided subject to [TI's Terms of Sale](#) or other applicable terms available either on [ti.com](https://www.ti.com) or provided in conjunction with such TI products. TI's provision of these resources does not expand or otherwise alter TI's applicable warranties or warranty disclaimers for TI products.

TI objects to and rejects any additional or different terms you may have proposed.

Mailing Address: Texas Instruments, Post Office Box 655303, Dallas, Texas 75265
Copyright © 2024, Texas Instruments Incorporated

Looking for pricing, stock, or lifecycle information?

Click below to explore more details on WIN SOURCE:

 [View LM5008MM](#) on WIN SOURCE

 [Texas Instruments](#) Information

Optimize Your Supply Chain with WIN SOURCE Solutions

-  Global Sourcing Solution
-  Obsolete Management
-  Cost Control Management
-  Shortage Management
-  Alternative Solution
-  Excess Inventory Management