



THE DATASHEET OF LM5017MRE/NOPB



Table of Contents

1 Features	1	7.3 Feature Description	9
2 Applications	1	7.4 Device Functional Modes	13
3 Description	1	8 Application and Implementation	14
4 Revision History	2	8.1 Application Information	14
5 Pin Configuration and Functions	3	8.2 Typical Application	14
6 Specifications	4	9 Power Supply Recommendations	23
6.1 Absolute Maximum Ratings	4	10 Layout	23
6.2 ESD Ratings	4	10.1 Layout Guidelines	23
6.3 Recommended Operating Conditions	4	10.2 Layout Example	23
6.4 Thermal Information	4	11 Device and Documentation Support	24
6.5 Electrical Characteristics	5	11.1 Documentation Support	24
6.6 Timing Requirements	5	11.2 Trademarks	24
6.7 Typical Characteristics	6	11.3 Electrostatic Discharge Caution	24
7 Detailed Description	8	11.4 Glossary	24
7.1 Overview	8	12 Mechanical, Packaging, and Orderable Information	24
7.2 Functional Block Diagram	8		

4 Revision History

Changes from Revision G (December 2013) to Revision H	Page
• Added package designators to pin out drawings.	3
• Changed <i>Thermal Information</i> table.	4
• Added D1 to Figure 12	13
• Updated the calculation for K from 10^{-10} to 10^{-11}	15
• Changed <i>Series Ripple Resistor R_C</i> section to <i>Type III Ripple Circuit</i>	16

Changes from Revision F (September 2013) to Revision G	Page
• Changed formatting throughout document to the TI standard	1
• Changed minimum operating input voltage from 9 V to 7.5 V in <i>Features</i>	1
• Changed minimum operating input voltage from 9 V to 7.5 V in <i>Typical Application</i>	1
• Changed minimum operating input voltage from 9 V to 7.5 V in <i>Pin Descriptions</i>	3
• Added Maximum Junction Temperature	4
• Changed minimum operating input voltage from 9 V to 7.5 V in <i>Recommended Operating Conditions</i>	4

Changes from Revision E (July 2013) to Revision F	Page
• Added SW to RTN (100 ns transient) to <i>Absolute Maximum Ratings</i>	4

5 Pin Configuration and Functions

8-Pin SO PowerPAD
DDA Package
Top View

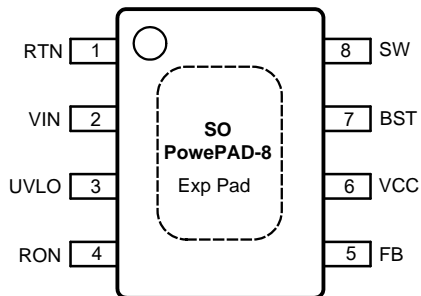

8-Pin WSON
NGU Package
Top View

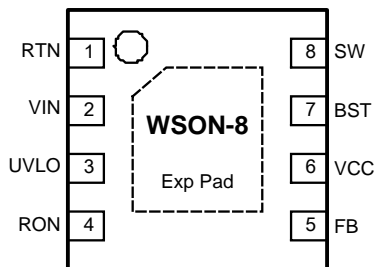

Pin Functions

PIN		I/O	DESCRIPTION	APPLICATION INFORMATION
NO.	NAME			
1	RTN	—	Ground	Ground connection of the integrated circuit.
2	VIN	I	Input Voltage	Operating input range is 7.5 V to 100 V.
3	UVLO	I	Input Pin of Undervoltage Comparator	Resistor divider from V_{IN} to UVLO to GND programs the undervoltage detection threshold. An internal current source is enabled when UVLO is above 1.225 V to provide hysteresis. When UVLO pin is pulled below 0.66 V externally, the regulator is in shutdown mode.
4	RON	I	On-Time Control	A resistor between this pin and V_{IN} sets the buck switch on-time as a function of V_{IN} . Minimum recommended on-time is 100 ns at max input voltage.
5	FB	I	Feedback	This pin is connected to the inverting input of the internal regulation comparator. The regulation level is 1.225 V.
6	VCC	O	Output from the Internal High Voltage Series Pass Regulator. Regulated at 7.6 V	The internal V_{CC} regulator provides bias supply for the gate drivers and other internal circuitry. A 1.0 μ F decoupling capacitor is recommended.
7	BST	I	Bootstrap Capacitor	An external capacitor is required between the BST and SW pins (0.01- μ F ceramic). The BST pin capacitor is charged by the V_{CC} regulator through an internal diode when the SW pin is low.
8	SW	O	Switching Node	Power switching node. Connect to the output inductor and bootstrap capacitor.
	EP	—	Exposed Pad	Exposed pad must be connected to the RTN pin. Solder to the system ground plane on application board for reduced thermal resistance.

6 Specifications

6.1 Absolute Maximum Ratings⁽¹⁾

	MIN	MAX	UNIT
V _{IN} , UVLO to RTN	−0.3	100	V
SW to RTN	−1.5	V _{IN} +0.3	V
SW to RTN (100 ns transient)	−5	V _{IN} +0.3	V
BST to V _{CC}		100	V
BST to SW		13	V
R _{ON} to RTN	−0.3	100	V
V _{CC} to RTN	−0.3	13	V
FB to RTN	−0.3	5	V
Lead Temperature ⁽²⁾		200	°C
Maximum Junction Temperature ⁽³⁾		150	°C
Storage temperature, T _{stg}	−55	150	°C

- (1) *Absolute Maximum Ratings* are limits beyond which damage to the device may occur. *Recommended Operating Conditions* are conditions under which operation of the device is intended to be functional. For ensured specifications and test conditions, see the *Electrical Characteristics*. The RTN pin is the GND reference electrically connected to the substrate.
- (2) For detailed information on soldering plastic SO PowerPAD package, refer to *Absolute Maximum ratings for Soldering (SNOA549)*. Maximum solder time not to exceed 4 seconds.
- (3) High junction temperatures degrade operating lifetimes. Operating lifetime is de-rated for junction temperatures greater than 125°C.

6.2 ESD Ratings

		VALUE	UNIT
V _(ESD) Electrostatic discharge	Human-body model (HBM), per ANSI/ESDA/JEDEC JS-001 ⁽¹⁾	±2000	V
	Charged-device model (CDM), per JEDEC specification JESD22-C101 ⁽²⁾	±750	

- (1) JEDEC document JEP155 states that 500-V HBM allows safe manufacturing with a standard ESD control process.
- (2) JEDEC document JEP157 states that 250-V CDM allows safe manufacturing with a standard ESD control process.

6.3 Recommended Operating Conditions

over operating free-air temperature range (unless otherwise noted)⁽¹⁾

	MIN	MAX	UNIT
V _{IN} Voltage ⁽¹⁾	7.5	100	V
Operating Junction Temperature ⁽²⁾	−40	125	°C

- (1) *Recommended Operating Conditions* are conditions under the device is intended to be functional. For specifications and test conditions, see *Electrical Characteristics*.
- (2) High junction temperatures degrade operating lifetimes. Operating lifetime is de-rated for junction temperatures greater than 125°C

6.4 Thermal Information

THERMAL METRIC ⁽¹⁾	LM5017		UNIT
	NGU	DDA	
	8 PINS	8 PINS	
R _{θJA} Junction-to-ambient thermal resistance	41.3	41.1	°C/W
R _{θJcbot} Junction-to-case (bottom) thermal resistance	3.2	2.4	
Ψ _{JB} Junction-to-board thermal characteristic parameter	19.2	24.4	
R _{θJB} Junction-to-board thermal resistance	19.1	30.6	
R _{θJctop} Junction-to-case (top) thermal resistance	34.7	37.3	
Ψ _{JT} Junction-to-top thermal characteristic parameter	0.3	6.7	

- (1) For more information about traditional and new thermal metrics, see the *IC Package Thermal Metrics* application report ([SPRA953](#)).

6.5 Electrical Characteristics

Typical values correspond to $T_J = 25^\circ\text{C}$. Minimum and maximum limits apply over -40°C to 125°C junction temperature range, unless otherwise stated. $V_{IN} = 48\text{ V}$ unless otherwise stated. See ⁽¹⁾

PARAMETER		TEST CONDITIONS	MIN	TYP	MAX	UNIT
V_{CC} SUPPLY						
V _{CC} Reg	V _{CC} Regulator Output	$V_{IN} = 48\text{ V}$, $I_{CC} = 20\text{ mA}$	6.25	7.6	8.55	V
	V _{CC} Current Limit	$V_{IN} = 48\text{ V}^{(2)}$	26			mA
	V _{CC} Undervoltage Lockout Voltage (V _{CC} increasing)	$-40 \leq T_J \leq 125$	4.15	4.5	4.9	V
	V _{CC} Undervoltage Hysteresis			300		mV
	V _{CC} Drop Out Voltage	$V_{IN} = 9\text{ V}$, $I_{CC} = 20\text{ mA}$		2.3		V
	I _{IN} Operating Current	Non-Switching, FB = 3 V		1.75		mA
	I _{IN} Shutdown Current	UVLO = 0 V		50	225	μA
SWITCH CHARACTERISTICS						
	Buck Switch R _{DS(ON)}	$I_{TEST} = 200\text{ mA}$, BST-SW = 7 V		0.8	1.8	Ω
	Synchronous R _{DS(ON)}	$I_{TEST} = 200\text{ mA}$		0.45	1	Ω
	Gate Drive UVLO	$V_{BST} - V_{SW}$ Rising	2.4	3	3.6	V
	Gate Drive UVLO Hysteresis			260		mV
CURRENT LIMIT						
	Current Limit Threshold	$-40^\circ\text{C} \leq T_J \leq 125^\circ\text{C}$	0.7	1.02	1.3	A
	Current Limit Response Time	Time to Switch Off		150		ns
	OFF-Time Generator (Test 1)	FB = 0.1 V, $V_{IN} = 48\text{ V}$		12		μs
	OFF-Time Generator (Test 2)	FB = 1.0 V, $V_{IN} = 48\text{ V}$		2.5		μs
REGULATION AND OVERVOLTAGE COMPARATORS						
	FB Regulation Level	Internal Reference Trip Point for Switch ON	1.2	1.225	1.25	V
	FB Overvoltage Threshold	Trip Point for Switch OFF		1.62		V
	FB Bias Current			60		nA
UNDERVOLTAGE SENSING FUNCTION						
	UV Threshold	UV Rising	1.19	1.225	1.26	V
	UV Hysteresis Input Current	UV = 2.5 V	-10	-20	-29	μA
	Remote Shutdown Threshold	Voltage at UVLO Falling	0.32	0.66		V
	Remote Shutdown Hysteresis			110		mV
THERMAL SHUTDOWN						
T _{sd}	Thermal Shutdown Temperature			165		°C
	Thermal Shutdown Hysteresis			20		°C

- (1) All hot and cold limits are specified by correlating the electrical characteristics to process and temperature variations and applying statistical process control.
- (2) V_{CC} provides self bias for the internal gate drive and control circuits. Device thermal limitations limit external loading.

6.6 Timing Requirements

Typical values correspond to $T_J = 25^\circ\text{C}$. Minimum and maximum limits apply over -40°C to 125°C junction temperature range unless otherwise stated. $V_{IN} = 48\text{ V}$ unless otherwise stated.

		MIN	NOM	MAX	UNIT
ON-TIME GENERATOR					
T _{ON} Test 1	$V_{IN} = 32\text{ V}$, R _{ON} = 100 k	270	350	460	ns
T _{ON} Test 2	$V_{IN} = 48\text{ V}$, R _{ON} = 100 k	188	250	336	ns
T _{ON} Test 3	$V_{IN} = 75\text{ V}$, R _{ON} = 250 k	250	370	500	ns
T _{ON} Test 4	$V_{IN} = 10\text{ V}$, R _{ON} = 250 k	1880	3200	4425	ns
MINIMUM OFF-TIME					
	Minimum Off-Timer		144		ns

6.7 Typical Characteristics

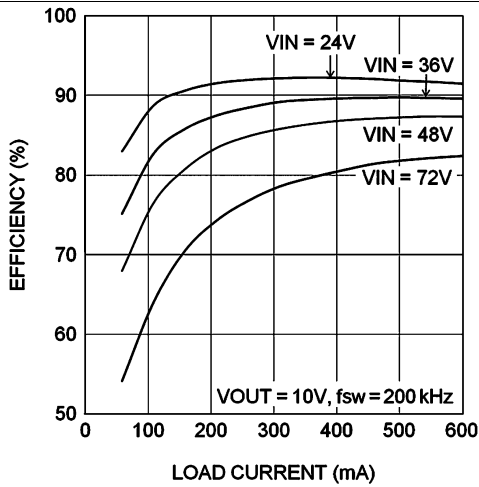

Figure 1. Efficiency at 200 kHz, 10 V

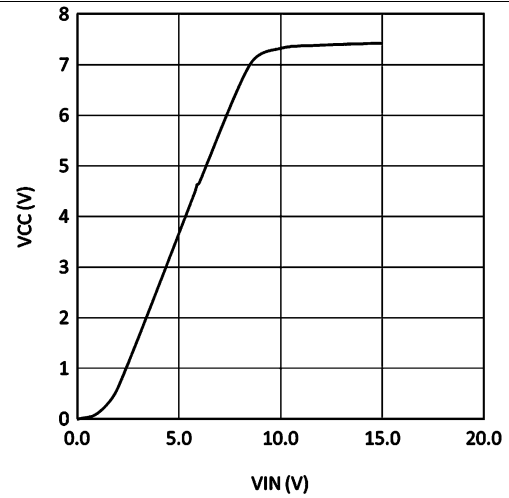

Figure 2. V_{CC} vs V_{IN}

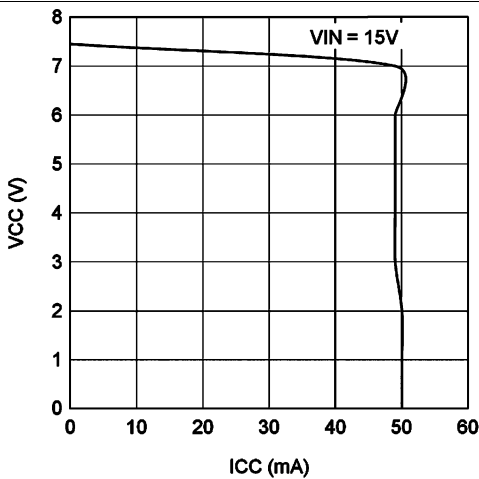

Figure 3. V_{CC} vs I_{CC}

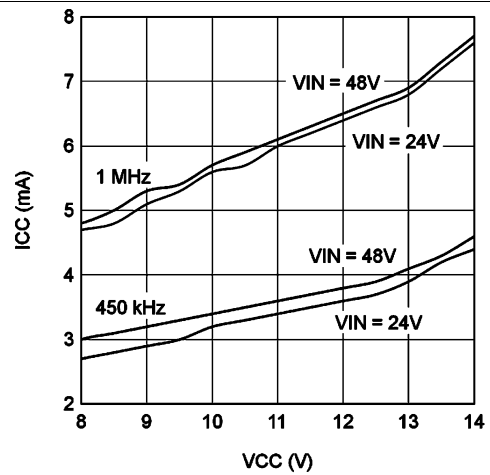

Figure 4. I_{CC} vs External V_{CC}

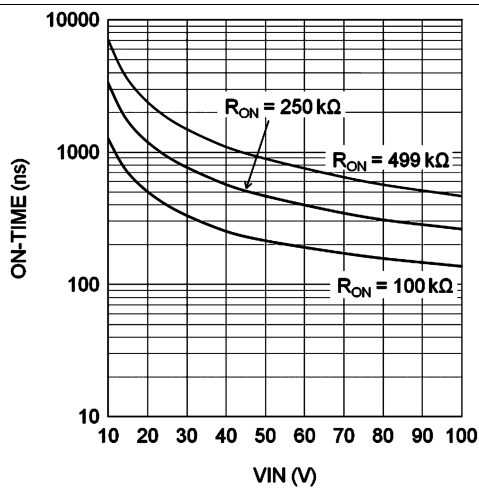

Figure 5. T_{ON} vs V_{IN} and R_{ON}

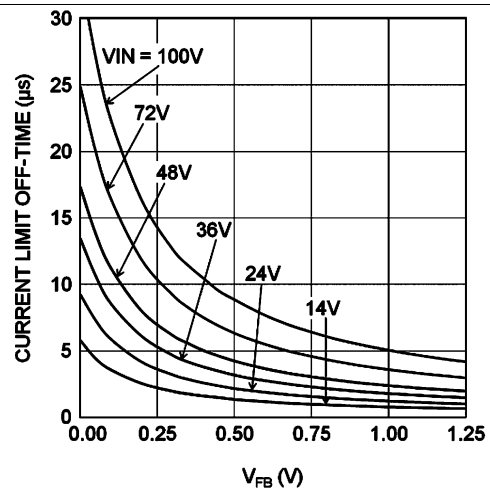

Figure 6. $T_{OFF} (I_{LIM})$ vs V_{FB} and V_{IN}

Typical Characteristics (continued)

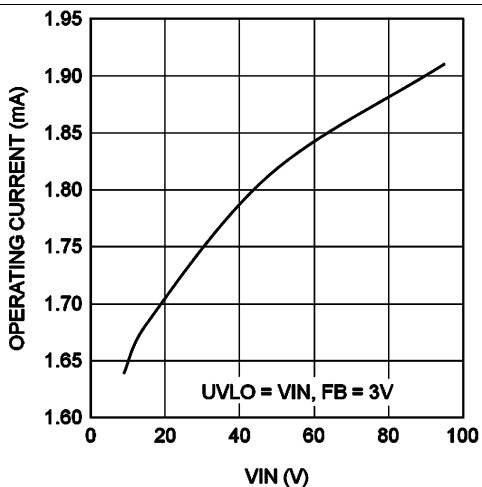

Figure 7. I_{IN} vs V_{IN} (Operating, Non-Switching)

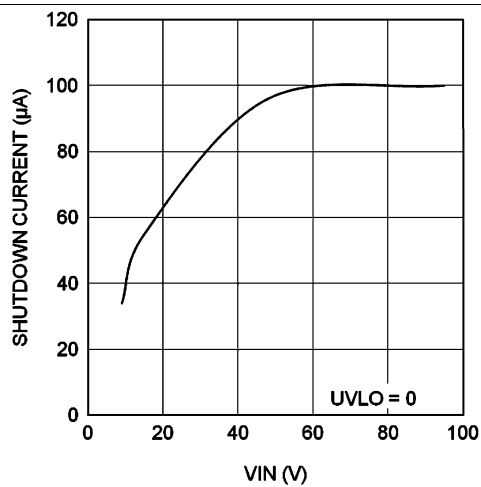

Figure 8. I_{IN} vs V_{IN} (Shutdown)

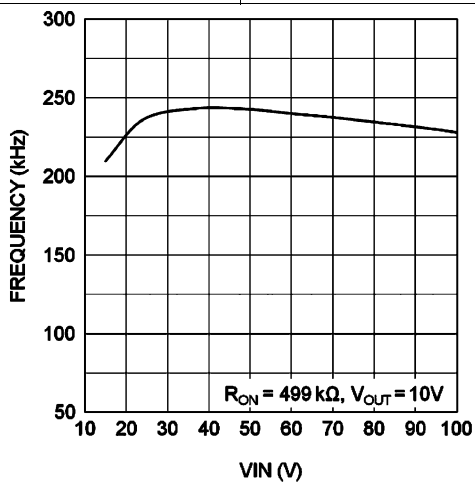

Figure 9. Switching Frequency vs V_{IN}

7 Detailed Description

7.1 Overview

The LM5017 step-down switching regulator features all the functions needed to implement a low cost, efficient, buck converter capable of supplying up to 0.6 A to the load. This high voltage regulator contains 100-V, N-channel buck and synchronous switches, is easy to implement, and is provided in thermally enhanced HSOP PowerPAD-8 and WSON-8 packages. The regulator operation is based on a constant on-time control scheme using an on-time inversely proportional to V_{IN} . This control scheme does not require loop compensation. The current limit is implemented with a forced off-time inversely proportional to V_{OUT} . This scheme ensures short circuit protection while providing minimum foldback.

The LM5017 can be applied in numerous applications to efficiently regulate down higher voltages. This regulator is well suited for 48-V telecom and automotive power bus ranges. Protection features include: thermal shutdown, Undervoltage Lockout (UVLO), minimum forced off-time, and an intelligent current limit.

7.2 Functional Block Diagram

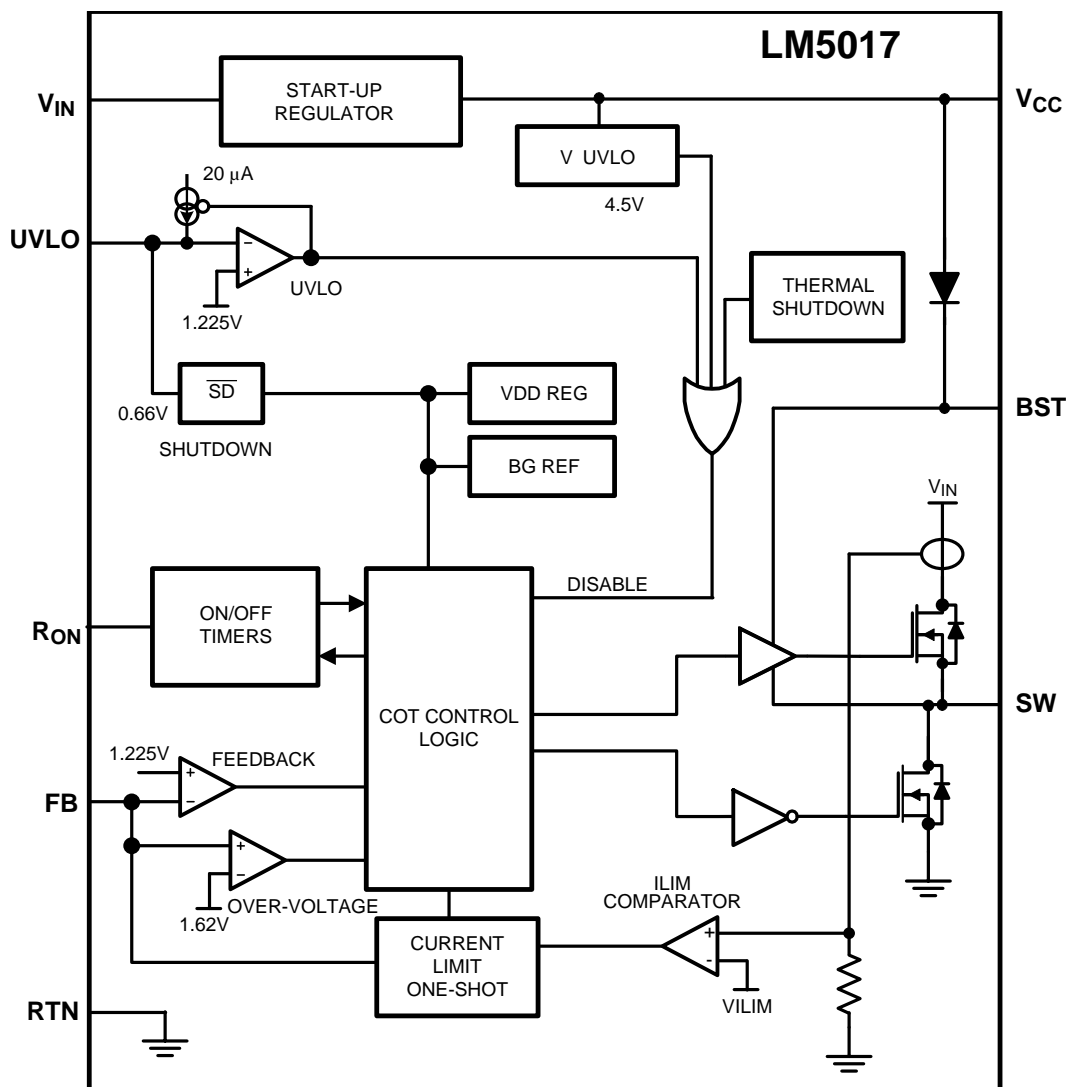

7.3 Feature Description

7.3.1 Control Overview

The LM5017 buck regulator employs a control principle based on a comparator and a one-shot on-timer, with the output voltage feedback (FB) compared to an internal reference (1.225 V). If the FB voltage is below the reference the internal buck switch is turned on for the one-shot timer period, which is a function of the input voltage and the programming resistor (R_{ON}). Following the on-time the switch remains off until the FB voltage falls below the reference, but never before the minimum off-time forced by the minimum off-time one-shot timer. When the FB pin voltage falls below the reference and the minimum off-time one-shot period expires, the buck switch is turned on for another on-time one-shot period. This will continue until regulation is achieved and the FB voltage is approximately equal to 1.225 V (typ).

In a synchronous buck converter, the low side (sync) FET is 'on' when the high side (buck) FET is 'off'. The inductor current ramps up when the high side switch is 'on' and ramps down when the high side switch is 'off'. There is no diode emulation feature in this IC, and therefore, the inductor current may ramp in the negative direction at light load. This causes the converter to operate in continuous conduction mode (CCM) regardless of the output loading. The operating frequency remains relatively constant with load and line variations. The operating frequency can be calculated as shown in Equation 1.

$$f_{SW} = \frac{V_{OUT}}{K \times R_{ON}} \quad (1)$$

Where:

$$K = 9 \times 10^{-11}$$

The output voltage (V_{OUT}) is set by two external resistors (R_{FB1} , R_{FB2}). The regulated output voltage is calculated as shown in Equation 2.

$$V_{OUT} = 1.225V \times \frac{R_{FB2} + R_{FB1}}{R_{FB1}} \quad (2)$$

This regulator regulates the output voltage based on ripple voltage at the feedback input, requiring a minimum amount of ESR for the output capacitor (C_{OUT}). A minimum of 25 mV of ripple voltage at the feedback pin (FB) is required for the LM5017. In cases where the capacitor ESR is too small, additional series resistance may be required (R_C in Figure 10).

For applications where lower output voltage ripple is required the output can be taken directly from a low ESR output capacitor, as shown in Figure 10. However, R_C slightly degrades the load regulation.

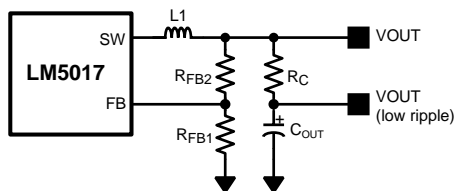

Figure 10. Low Ripple Output Configuration

7.3.2 V_{CC} Regulator

The LM5017 device contains an internal high voltage linear regulator with a nominal output of 7.6 V. The input pin (V_{IN}) can be connected directly to the line voltages up to 100 V. The V_{CC} regulator is internally current limited to 30 mA. The regulator sources current into the external capacitor at V_{CC} . This regulator supplies current to internal circuit blocks including the synchronous MOSFET driver and the logic circuits. When the voltage on the V_{CC} pin reaches the undervoltage lockout (V_{CC} UVLO) threshold of 4.5 V, the IC is enabled.

An internal diode connected from V_{CC} to the BST pin replenishes the charge in the gate drive bootstrap capacitor when SW pin is low.

Feature Description (continued)

At high input voltages, the power dissipated in the high voltage regulator is significant and can limit the overall achievable output power. As an example, with the input at 48 V and switching at high frequency, the V_{CC} regulator may supply up to 7 mA of current resulting in $48\text{ V} \times 7\text{ mA} = 336\text{ mW}$ of power dissipation. If the V_{CC} voltage is driven externally by an alternate voltage source between 8.55 V and 14 V, the internal regulator is disabled. This reduces the power dissipation in the IC.

7.3.3 Regulation Comparator

The feedback voltage at FB is compared to an internal 1.225 V reference. In normal operation, when the output voltage is in regulation, an on-time period is initiated when the voltage at FB falls below 1.225 V. The high side switch will stay on for the on-time, causing the FB voltage to rise above 1.225 V. After the on-time period, the high side switch will stay off until the FB voltage again falls below 1.225 V. During start-up, the FB voltage will be below 1.225 V at the end of each on-time, causing the high side switch to turn on immediately after the minimum forced off-time of 144 ns. The high side switch can be turned off before the on-time is over if the peak current in the inductor reaches the current limit threshold.

7.3.4 Overvoltage Comparator

The feedback voltage at FB is compared to an internal 1.62 V reference. If the voltage at FB rises above 1.62 V the on-time pulse is immediately terminated. This condition can occur if the input voltage and/or the output load changes suddenly. The high side switch will not turn on again until the voltage at FB falls below 1.225 V.

7.3.5 On-Time Generator

The on-time for the LM5017 device is determined by the R_{ON} resistor and is inversely proportional to the input voltage (V_{IN}), resulting in a nearly constant frequency as V_{IN} is varied over the operating range. The on-time for the LM5017 can be calculated using [Equation 3](#).

$$T_{ON} = \frac{10^{-10} \times R_{ON}}{V_{IN}} \quad (3)$$

See [Figure 5](#). R_{ON} should be selected for a minimum on-time (at maximum V_{IN}) greater than 100 ns for proper operation. This requirement limits the maximum switching frequency for high V_{IN} .

7.3.6 Current Limit

The LM5017 device contains an intelligent current limit off-timer. If the current in the buck switch exceeds 1.02 A, the present cycle is immediately terminated, and a non-resettable off-timer is initiated. The length of the off-time is controlled by the FB voltage and the input voltage V_{IN} . As an example, when $FB = 0\text{ V}$ and $V_{IN} = 48\text{ V}$, the off-time is set to 16 μs . This condition occurs when the output is shorted and during the initial part of start-up. This V_{IN} dependent off-time ensures safe short circuit operation up to the maximum input voltage of 100 V.

In cases of overload where the FB voltage is above zero volts (not a short circuit) the current limit off-time is reduced. Reducing the off-time during less severe overloads reduces the amount of foldback, recovery time, and start-up time. The off-time is calculated from [Equation 4](#).

$$T_{OFF(ILIM)} = \frac{0.07 \times V_{IN}}{V_{FB} + 0.2\text{V}} \mu\text{s} \quad (4)$$

The current limit protection feature is peak limited. The maximum average output current will be less than the peak.

7.3.7 N-Channel Buck Switch and Driver

The LM5017 device integrates an N-Channel Buck switch and associated floating high voltage gate driver. The gate driver circuit works in conjunction with an external bootstrap capacitor and an internal high voltage diode. A 0.01 μF ceramic capacitor connected between the BST pin and the SW pin provides the voltage to the driver during the on-time. During each off-time, the SW pin is at approximately 0 V, and the bootstrap capacitor charges from V_{CC} through the internal diode. The minimum off-timer, set to 144 ns, ensures a minimum time each cycle to recharge the bootstrap capacitor.

Feature Description (continued)

7.3.8 Synchronous Rectifier

The LM5017 provides an internal synchronous N-Channel MOSFET rectifier. This MOSFET provides a path for the inductor current to flow when the high-side MOSFET is turned off.

The synchronous rectifier has no diode emulation mode, and is designed to keep the regulator in continuous conduction mode even with light loads which would otherwise result in discontinuous operation.

7.3.9 Undervoltage Detector

The LM5017 device contains a dual level undervoltage lockout (UVLO) circuit. A summary of threshold voltages and operational states is provided in [Device Functional Modes](#). When the UVLO pin voltage is below 0.66 V, the regulator is in a low current shutdown mode. When the UVLO pin voltage is greater than 0.66V but less than 1.225 V, the regulator is in standby mode. In standby mode the V_{CC} bias regulator is active while the regulator output is disabled. When the V_{CC} pin exceeds the V_{CC} undervoltage threshold and the UVLO pin voltage is greater than 1.225 V, normal operation begins. An external set-point voltage divider from V_{IN} to GND can be used to set the minimum operating voltage of the regulator.

UVLO hysteresis is accomplished with an internal 20- μ A current source that is switched on or off into the impedance of the set-point divider. When the UVLO threshold is exceeded, the current source is activated to quickly raise the voltage at the UVLO pin. The hysteresis is equal to the value of this current times the resistance R_{UV2} .

If the UVLO pin is connected directly to the V_{IN} pin, the regulator will begin operation once the V_{CC} undervoltage is satisfied.

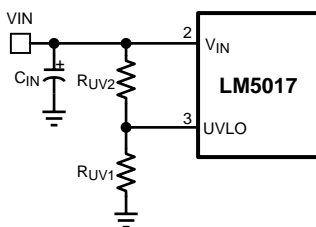

Figure 11. UVLO Resistor Setting

7.3.10 Thermal Protection

The LM5017 device should be operated so the junction temperature does not exceed 150°C during normal operation. An internal Thermal Shutdown circuit is provided to protect the LM5017 in the event of a higher than normal junction temperature. When activated, typically at 165°C, the regulator is forced into a low power reset state, disabling the buck switch and the V_{CC} regulator. This feature prevents catastrophic failures from accidental device overheating. When the junction temperature falls below 145°C (typical hysteresis = 20°C), the V_{CC} regulator is enabled, and normal operation is resumed.

7.3.11 Ripple Configuration

LM5017 uses Constant-On-Time (COT) control in which the on-time is terminated by an on-timer and the off-time is terminated by the feedback voltage (V_{FB}) falling below the reference voltage (V_{REF}). Therefore, for stable operation, the feedback voltage must decrease monotonically, in phase with the inductor current during the off-time. Furthermore, this change in feedback voltage (V_{FB}) during off-time must be larger than any noise component present at the feedback node.

Table 1 shows three different methods for generating appropriate voltage ripple at the feedback node. Type 1 and Type 2 ripple circuits couple the ripple at the output of the converter to the feedback node (FB). The output voltage ripple has two components:

1. Capacitive ripple caused by the inductor current ripple charging/discharging the output capacitor.
2. Resistive ripple caused by the inductor current ripple flowing through the ESR of the output capacitor.

Feature Description (continued)

The capacitive ripple is not in phase with the inductor current. As a result, the capacitive ripple does not decrease monotonically during the off-time. The resistive ripple is in phase with the inductor current and decreases monotonically during the off-time. The resistive ripple must exceed the capacitive ripple at the output node (V_{OUT}) for stable operation. If this condition is not satisfied unstable switching behavior is observed in COT converters, with multiple on-time bursts in close succession followed by a long off-time.

Type 3 ripple method uses R_r and C_r and the switch node (SW) voltage to generate a triangular ramp. This triangular ramp is ac coupled using C_{ac} to the feedback node (FB). Since this circuit does not use the output voltage ripple, it is ideally suited for applications where low output voltage ripple is required. See *AN-1481 Controlling Output Ripple and Achieving ESR Independence in Constant On-Time (COT) Regulator Designs (SNVA166)* for more details for each ripple generation method.

Table 1. Ripple Configuration

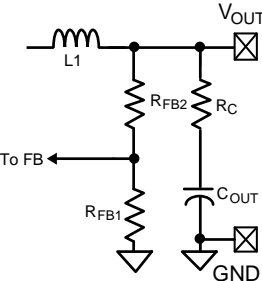
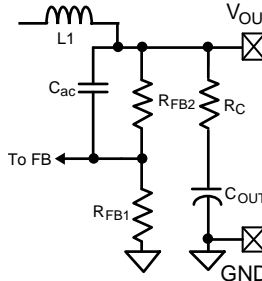
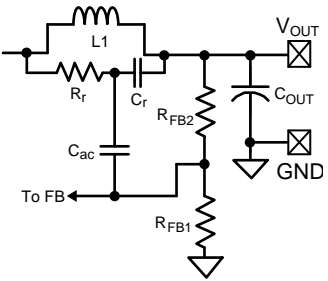
TYPE 1 LOWEST COST CONFIGURATION	TYPE 2 REDUCED RIPPLE CONFIGURATION	TYPE 3 MINIMUM RIPPLE CONFIGURATION
		
$R_C \geq \frac{25 \text{ mV}}{\Delta I_{L(\text{MIN})}} \times \frac{V_{OUT}}{V_{REF}} \quad (5)$	$C \geq \frac{5}{f_{sw} (R_{FB2} R_{FB1})}$ $R_C \geq \frac{25 \text{ mV}}{\Delta I_{L(\text{MIN})}} \quad (6)$	$R_r C_r \leq \frac{(V_{IN(\text{MIN})} - V_{OUT}) \times T_{ON}}{25 \text{ mV}} \quad (7)$ <p> $C_r = 3300 \text{ pF}$ $C_{ac} = 100 \text{ nF}$ </p>

7.3.12 Soft-Start

A soft-start feature can be implemented with the LM5017 using an external circuit. As shown in [Figure 12](#), the soft-start circuit consists of one capacitor, C_1 , two resistors, R_1 and R_2 , and a diode, D. During the initial start-up, the VCC voltage is established prior to the V_{OUT} voltage. Capacitor C_1 is discharged and D is thereby forward biased to pull up the FB voltage. The FB voltage exceeds the reference voltage (1.225 V) and switching is therefore disabled. As capacitor C_1 charges, the voltage at node B gradually decreases and switching commences. V_{OUT} will gradually rise to maintain the FB voltage at the reference voltage. Once the voltage at node B is less than a diode drop above FB voltage, the soft-start is finished and D is reverse biased.

During the initial part of the start-up, the FB voltage can be approximated as follows. Please note that the effect of R_1 has been ignored to simplify the calculation shown in [Equation 8](#).

$$V_{FB} = (V_{CC} - V_D) \times \frac{R_{FB1} \times R_{FB2}}{R_2 \times (R_{FB1} + R_{FB2}) + R_{FB1} \times R_{FB2}} \quad (8)$$

C_1 is charged after the first start up. Diode D1 is optional and can be added to discharge C_1 when the input voltage experiences a momentary drop to initialize the soft-start sequence.

To achieve the desired soft-start, the following design guidance is recommended:

(1) R_2 is selected so that V_{FB} is higher than 1.225 V for a V_{CC} of 4.5 V, but is lower than 5 V when V_{CC} is 8.55 V. If an external V_{CC} is used, V_{FB} should not exceed 5 V at maximum V_{CC} .

(2) C_1 is selected to achieve the desired start-up time that can be determined from [Equation 9](#).

$$t_s = C_1 \times \left(R_2 + \frac{R_{FB1} \times R_{FB2}}{R_{FB1} + R_{FB2}} \right) \quad (9)$$

(3) R_1 is used to maintain the node B voltage at zero after the soft-start is finished. A value larger than the feedback resistor divider is preferred. Note that the effect of R_1 is ignored in the previous equations.

Based on the schematic shown in Figure 13, selecting $C_1 = 1 \mu\text{F}$, $R_2 = 1 \text{ k}\Omega$, $R_1 = 30 \text{ k}\Omega$ results in a soft-start time of about 2 ms.

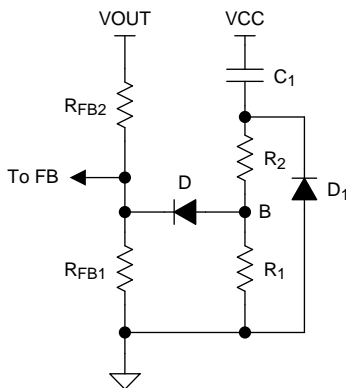

Figure 12. Soft-Start Circuit

7.4 Device Functional Modes

Table 2. UVLO Modes

UVLO	V _{CC} Regulator	MODE	DESCRIPTION
< 0.66 V	Disabled	Shutdown	V _{CC} regulator disabled. Switching disabled.
0.66 V – 1.225 V	Enabled	Standby	V _{CC} regulator enabled Switching disabled.
> 1.225 V	V _{CC} < 4.5 V	Standby	V _{CC} regulator enabled. Switching disabled.
	V _{CC} > 4.5 V	Operating	V _{CC} enabled. Switching enabled.

8 Application and Implementation

NOTE

Information in the following applications sections is not part of the TI component specification, and TI does not warrant its accuracy or completeness. TI's customers are responsible for determining suitability of components for their purposes. Customers should validate and test their design implementation to confirm system functionality.

8.1 Application Information

The LM5017 device is step-down dc-dc converter. The device is typically used to convert a higher dc voltage to a lower dc voltage with a maximum available output current of 650 mA. Use the following design procedure to select component values for the LM5017 device. Alternately, use the WEBENCH® software to generate a complete design. The WEBENCH software uses an iterative design procedure and accesses a comprehensive database of components when generating a design. This section presents a simplified discussion of the design process.

8.2 Typical Application

8.2.1 Application Circuit: 12.5-V to 95-V Input and 10-V, 600-mA Output Buck Converter

The application schematic of a buck supply is shown in Figure 13. For output voltage (V_{OUT}) more than one diode drop above the maximum regulation threshold of V_{CC} (8.55 V, see *Electrical Characteristics*), the V_{CC} pin can be connected to V_{OUT} through a diode (D2), as shown in Figure 13, for higher efficiency and lower power dissipation in the IC.

The design example below uses equations from the *Feature Description* with component names provided in the *Typical Application*. Corresponding component designators from Figure 13 are also provided for each selected value.

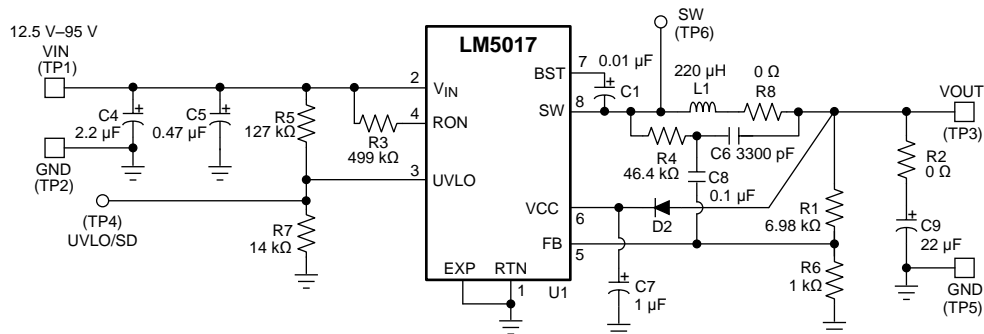

Figure 13. Final Schematic for 12.5-V to 95-V Input, and 10-V, 600-mA Output Buck Converter

8.2.1.1 Design Requirements

Selection of external components is illustrated through a design example. The design example specifications are shown in Table 3.

Table 3. Buck Converter Design Specifications

DESIGN PARAMETERS	VALUE
Input voltage range	12.5 V to 95 V
Output voltage	10 V
Maximum Load current	600 mA
Switching Frequency	≈ 225 kHz

8.2.1.2 Detailed Design Procedure

8.2.1.2.1 RFB1, RFB2

$V_{OUT} = V_{FB} \times (R_{FB2}/R_{FB1} + 1)$, and since $V_{FB} = 1.225\text{ V}$, the ratio of R_{FB2} to R_{FB1} calculates as 7:1. Standard values are chosen with $R_{FB2} = R1 = 6.98\text{ k}\Omega$ and $R_{FB1} = R6 = 1.00\text{ k}\Omega$. Other values could be used as long as the 7:1 ratio is maintained.

8.2.1.2.2 Frequency Selection

At the minimum input voltage, the maximum switching frequency of LM5017 is restricted by the forced minimum off-time ($T_{OFF(MIN)}$) as given by [Equation 10](#).

$$f_{SW(MAX)} = \frac{1 - D_{MAX}}{T_{OFF(MIN)}} = \frac{1 - 10/12.5}{200\text{ ns}} = 1\text{ MHz} \quad (10)$$

Similarly, at maximum input voltage, the maximum switching frequency of LM5017 is restricted by the minimum T_{ON} as given by [Equation 11](#).

$$f_{SW(MAX)} = \frac{D_{MIN}}{T_{ON(MIN)}} = \frac{10/95}{100\text{ ns}} = 1.05\text{ MHz} \quad (11)$$

Resistor R_{ON} sets the nominal switching frequency based on [Equation 12](#).

$$f_{SW} = \frac{V_{OUT}}{K \times R_{ON}} \quad (12)$$

Where:

$$K = 9 \times 10^{-11}$$

Operation at high switching frequency results in lower efficiency while providing the smallest solution. For this example a conservative 225 kHz was selected, resulting in $R_{ON} = 493\text{ k}\Omega$. A standard value for $R_{ON} = R3 = 499\text{ k}\Omega$ is selected.

8.2.1.2.3 Inductor Selection

The minimum inductance is selected to limit the output ripple to 15 to 40 percent of the maximum load current. In addition, the peak inductor current at maximum load should be smaller than the minimum current limit as given in [Electrical Characteristics](#) table.

The inductor current ripple is given by [Equation 13](#).

$$\Delta I_L = \frac{V_{IN} - V_{OUT}}{L1 \times f_{SW}} \times \frac{V_{OUT}}{V_{IN}} \quad (13)$$

The maximum ripple is observed at maximum input voltage. Substituting $V_{IN} = 95\text{ V}$ and $\Delta I_L = 40\text{ percent} \times I_{OUT(max)}$ results in $L1 = 198\text{ }\mu\text{H}$. The next higher standard value of $220\text{ }\mu\text{H}$ is chosen. The peak-to-peak minimum and maximum inductor current ripple are 40 mA and 181 mA at the minimum and maximum input voltages respectively. The peak inductor and switch current is given by [Equation 14](#).

$$I_{L(peak)} = I_{OUT} + \frac{\Delta I_{L(MAX)}}{2} = 690\text{ mA} \quad (14)$$

690 mA is less than the minimum current limit threshold of 0.7 A. The selected inductor should be able to withstand the maximum current limit of 1.3 A during startup and overload conditions without saturating.

8.2.1.2.4 Output Capacitor

The output capacitor is selected to minimize the capacitive ripple across it. The maximum ripple is observed at maximum input voltage and is given by:

$$C_{OUT} = \frac{\Delta I_L}{8 \times f_{sw} \times \Delta V_{ripple}} \quad (15)$$

Where:

ΔV_{ripple} is the voltage ripple across the capacitor

Assuming $V_{IN} = 95\text{ V}$ and substituting $\Delta V_{\text{ripple}} = 10\text{ mV}$ gives $C_{OUT} = 10.1\text{ }\mu\text{F}$. A 22- μF standard value is selected for $C_{OUT} = \text{C9}$. An X5R or X7R type capacitor with a voltage rating 16 V or higher should be selected.

8.2.1.2.5 Type III Ripple Circuit

Type III ripple circuit as described in [Ripple Configuration](#) is chosen for this example. For a constant on-time converter to be stable, the injected in-phase ripple should be larger than the capacitive ripple on C_{OUT} .

Using the type III ripple circuit equation, the target ripple will be greater than the capacitive ripple generated at the primary output if the following condition is satisfied:

$$C_r = C6 = 3300\text{ pF}$$

$$C_{ac} = C8 = 100\text{ nF}$$

$$R_r \leq \frac{(V_{IN(MIN)} - V_{OUT}) \times T_{ON(VINMIN)}}{(25\text{mV} \times C_r)} \quad (16)$$

For T_{ON} , refer to [Equation 3](#).

Ripple resistor R_r is calculated to be 57.6 k Ω . This value provides the minimum ripple for stable operation. A smaller resistance should be selected to allow for variations in T_{ON} , C_{OUT} , and other components. $R_r = R4 = 46.4\text{ k}\Omega$ is selected for this example application.

8.2.1.2.6 V_{CC} and Bootstrap Capacitor

The V_{CC} capacitor provides charge to bootstrap capacitor as well as internal circuitry and low side gate driver. The Bootstrap capacitor provides charge to high side gate driver. The recommended value for $C_{VCC} = C7 = 1\text{ }\mu\text{F}$. A good value for $C_{BST} = C1 = 0.01\text{ }\mu\text{F}$.

8.2.1.2.7 Input Capacitor

Input capacitor should be large enough to limit the input voltage ripple as shown in [Equation 17](#).

$$C_{IN} \geq \frac{I_{OUT(MAX)}}{8 \times f_{SW} \times \Delta V_{IN}} \quad (17)$$

Choosing a $\Delta V_{IN} = 0.5\text{ V}$ gives a minimum $C_{IN} = 0.66\text{ }\mu\text{F}$. A standard value of 2.2 μF is selected for $C_{IN} = C4$. The input capacitor should be rated for the maximum input voltage under all conditions. A 100-V, X7R dielectric should be selected for this design.

The input capacitor should be placed directly across V_{IN} and RTN (pin 1 and 2) of the IC. If it is not possible to place all of the input capacitor close to the IC, a 0.47- μF capacitor should be placed near the IC to provide a bypass path for the high frequency component of the switching current.

8.2.1.2.8 UVLO Resistors

The UVLO resistors R_{FB1} and R_{FB2} set the UVLO threshold and hysteresis according to the relationship shown in [Equation 18](#) and [Equation 19](#).

$$V_{IN(HYS)} = I_{HYS} \times R_{UV2} \quad (18)$$

$$I_{IN(UVLO,rising)} = 1.225\text{V} \times \left(\frac{R_{UV2}}{R_{UV1}} + 1 \right) \quad (19)$$

Where:

$$I_{HYS} = 20\text{ }\mu\text{A}$$

Setting UVLO hysteresis of 2.5 V and UVLO rising threshold of 12 V results in $R_{UV1} = 14.53\text{ k}\Omega$ and $R_{UV2} = 125\text{ k}\Omega$. Selecting standard values of $R_{UV1} = R7 = 14\text{ k}\Omega$ and $R_{UV2} = R5 = 127\text{ k}\Omega$ results in UVLO threshold and hysteresis of 12.4 V and 2.5 V respectively.

8.2.1.3 Application Curves

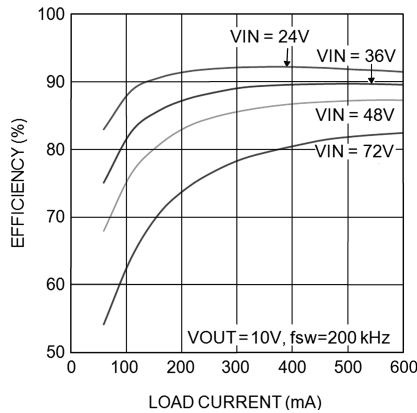

Figure 14. Efficiency vs Load Current

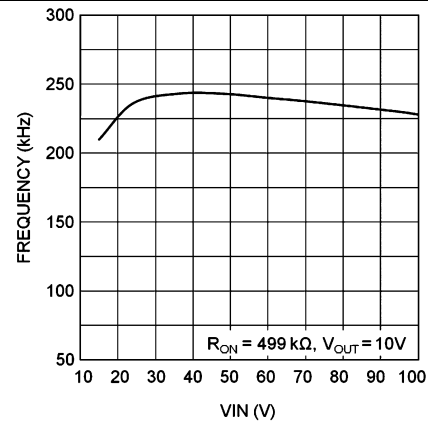

Figure 15. Frequency vs Input Voltage

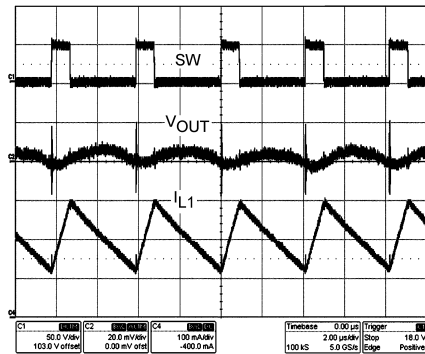

Figure 16. Typical Switching Waveform ($V_{in} = 48\text{ V}$, $I_{out} = 200\text{ mA}$)

8.2.2 Isolated DC-DC Converter Using LM5017

An isolated supply using LM5017 is shown in Figure 17. Inductor (L) in a typical buck circuit is replaced with a coupled inductor (X1). A diode (D1) is used to rectify the voltage on a secondary output. The nominal voltage at the secondary output (V_{OUT2}) is given by Equation 20.

$$V_{OUT2} = V_{OUT1} \times \frac{N_S}{N_P} - V_F \tag{20}$$

Where:

V_F is the forward voltage drop of D1

N_P and N_S are the number of turns on the primary and secondary of coupled inductor X1.

For output voltage (V_{OUT1}) more than one diode drop above the maximum V_{CC} (8.55 V), the V_{CC} pin can be diode connected to V_{OUT1} for higher efficiency and low dissipation in the IC. See AN-2204 (SNVA611) for a complete isolated bias design with LM5017.

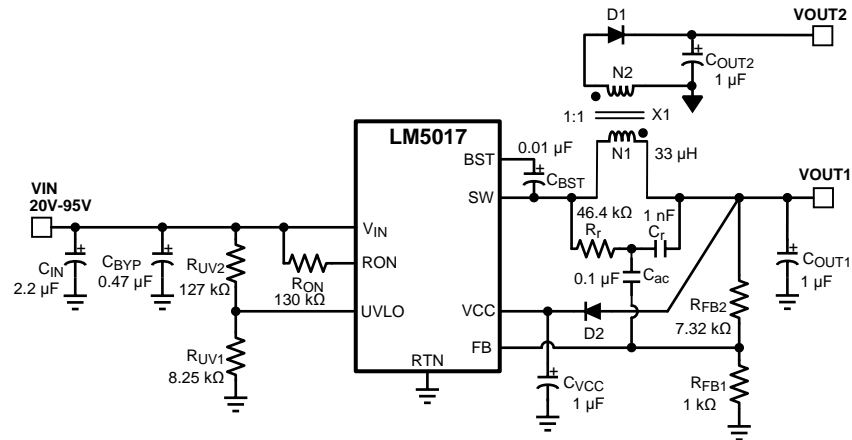
Figure 17. Typical Isolated Application Schematic

8.2.2.1 Design Requirements

DESIGN PARAMETERS	VALUE
Input Voltage Range	20 V – 100 V
Primary Output Voltage	10 V
Secondary (Isolated) Output Voltage	9.5 V
Maximum Load Current (Primary + Secondary)	300 mA
Maximum Power Output	3 W
Nominal Switching Frequency	750 kHz

8.2.2.2 Detailed Design Procedure

8.2.2.2.1 Transformer Turns Ratio

The transformer turns ratio is selected based on the ratio of the primary output voltage to the secondary (isolated) output voltage. In this design example, the two outputs are nearly equal and a 1:1 turns ratio transformer is selected. Therefore, $N2 / N1 = 1$.

If the secondary (isolated) output voltage is significantly higher or lower than the primary output voltage, a turns ratio less than or greater than 1 is recommended. The primary output voltage is normally selected based on the input voltage range such that the duty cycle of the converter does not exceed 50% at the minimum input voltage. This condition is satisfied if $VOUT1 < V_{IN_MIN} / 2$.

8.2.2.2.2 Total IOU

The total primary referred load current is calculated by multiplying the isolated output load(s) by the turns ratio of the transformer as shown in [Equation 21](#).

$$I_{OUT(MAX)} = I_{OUT1} + I_{OUT2} \times \frac{N2}{N1} = 0.3 \text{ A} \quad (21)$$

8.2.2.2.3 RFB1, RFB2

The feedback resistors are selected to set the primary output voltage. The selected value for R_{FB1} is 1 k Ω . R_{FB2} can be calculated using the following equations to set V_{OUT1} to the specified value of 10 V. A standard resistor value of 7.32 k Ω is selected for R_{FB2} .

$$V_{OUT1} = 1.225V \times \left(1 + \frac{R_{FB2}}{R_{FB1}}\right) \quad (22)$$

$$\rightarrow R_{FB2} = \left(\frac{V_{OUT1}}{1.225} - 1\right) \times R_{FB1} = 7.16 \text{ k}\Omega \quad (23)$$

8.2.2.2.4 Frequency Selection

Equation 24 is used to calculate the value of R_{ON} required to achieve the desired switching frequency.

$$f_{SW} = \frac{V_{OUT1}}{K \times R_{ON}} \quad (24)$$

Where $K = 9 \times 10^{-11}$

For V_{OUT1} of 10 V and f_{SW} of 750 kHz, the calculated value of R_{ON} is 148 k Ω . A lower value of 130 k Ω is selected for this design to allow for second order effects at high switching frequency that are not included in Equation 24.

8.2.2.2.5 Transformer Selection

A coupled inductor or a flyback-type transformer is required for this topology. Energy is transferred from primary to secondary when the low-side synchronous switch of the buck converter is conducting.

The maximum inductor primary ripple current that can be tolerated without exceeding the buck switch peak current limit threshold (0.7 A minimum) is given by Equation 25.

$$\Delta I_{L1} = \left(0.7 - I_{OUT1} - I_{OUT2} \times \frac{N2}{N1}\right) \times 2 = 0.8 \text{ A} \quad (25)$$

Using the maximum peak-to-peak inductor ripple current ΔI_{L1} from Equation 25, the minimum inductor value is given by Equation 26.

$$L1 = \frac{V_{IN(MAX)} - V_{OUT}}{\Delta I_{L1} \times f_{SW}} \times \frac{V_{OUT}}{V_{IN(MAX)}} = 14.9 \mu\text{H} \quad (26)$$

A higher value of 33 μH is selected to insure the high-side switch current does not exceed the minimum peak current limit threshold. With this inductance, the inductor current ripple is $\Delta I_{L1} = 0.36 \text{ A}$ at the maximum V_{IN} .

8.2.2.2.6 Primary Output Capacitor

In a conventional buck converter the output ripple voltage is calculated as shown in Equation 27.

$$\Delta V_{OUT} = \frac{\Delta I_{L1}}{8 \times f \times C_{OUT1}} \quad (27)$$

To limit the primary output ripple voltage ΔV_{OUT1} to approximately 50 mV, an output capacitor C_{OUT1} of 1.2 μF would be required for a conventional buck.

Figure 18 shows the primary winding current waveform (I_{L1}) of a Fly-Buck™ converter. The reflected secondary winding current adds to the primary winding current during the buck switch off-time. Because of this increased current, the output voltage ripple is not the same as in conventional buck converter. The output capacitor value calculated in Equation 27 should be used as the starting point. Optimization of output capacitance over the entire line and load range must be done experimentally. If the majority of the load current is drawn from the secondary isolated output, a better approximation of the primary output voltage ripple is given by Equation 28.

$$\Delta V_{OUT1} = \frac{\left(I_{OUT2} \times \frac{N2}{N1}\right) \times T_{ON(MAX)}}{C_{OUT1}} \approx 67 \text{ mV} \quad (28)$$

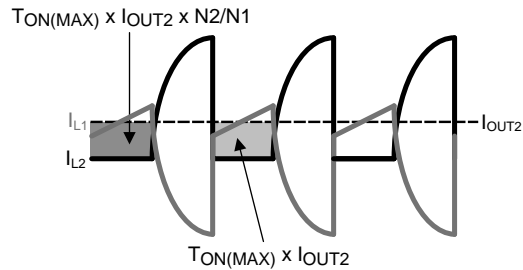

Figure 18. Current Waveforms for C_{OUT1} Ripple Calculation

A standard 1- μ F, 25 V capacitor is selected for this design. If lower output voltage ripple is required, a higher value should be selected for C_{OUT1} and/or C_{OUT2} .

8.2.2.2.7 Secondary Output Capacitor

A simplified waveform for secondary output current (I_{OUT2}) is shown in Figure 19.

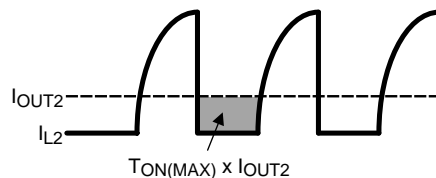

Figure 19. Secondary Current Waveforms for C_{OUT2} Ripple Calculation

The secondary output current (I_{OUT2}) is sourced by C_{OUT2} during on-time of the buck switch, T_{ON} . Ignoring the current transition times in the secondary winding, the secondary output capacitor ripple voltage can be calculated using Equation 29.

$$\Delta V_{OUT2} = \frac{I_{OUT2} \times T_{ON(MAX)}}{C_{OUT2}} \quad (29)$$

For a 1:1 transformer turns ratio, the primary and secondary voltage ripple equations are identical. Therefore, C_{OUT2} is chosen to be equal to C_{OUT1} (1 μ F) to achieve comparable ripple voltages on primary and secondary outputs.

If lower output voltage ripple is required, a higher value should be selected for C_{OUT1} and/or C_{OUT2} .

8.2.2.2.8 Type III Feedback Ripple Circuit

Type III ripple circuit as described in [Ripple Configuration](#) is required for the Fly-Buck topology. Type I and Type II ripple circuits use series resistance and the triangular inductor ripple current to generate ripple at V_{OUT} and the FB pin. The primary ripple current of a Fly-Buck is the combination of primary and reflected secondary currents as illustrated in Figure 18. In the Fly-Buck topology, Type I and Type II ripple circuits suffer from large jitter as the reflected load current affects the feedback ripple.

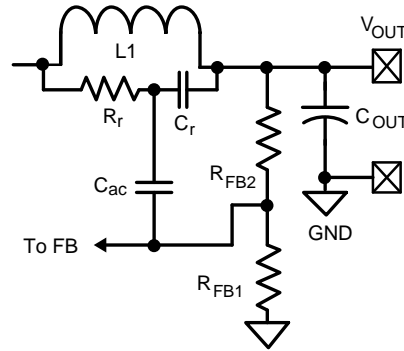

Figure 20. Type III Ripple Circuit

Selecting the Type III ripple components using the equations from [Ripple Configuration](#) will ensure that the FB pin ripple is be greater than the capacitive ripple from the primary output capacitor C_{OUT1} . The feedback ripple component values are chosen as shown in [Equation 30](#).

$$\begin{aligned} C_r &= 1000 \text{ pF} \\ C_{ac} &= 0.1 \text{ } \mu\text{F} \\ R_r C_r &\leq \frac{(V_{IN(MIN)} - V_{OUT}) \times T_{ON}}{50 \text{ mV}} \end{aligned} \quad (30)$$

The calculated value for R_r is 66 k Ω . This value provides the minimum ripple for stable operation. A smaller resistance should be selected to allow for variations in T_{ON} , C_{OUT1} and other components. For this design, R_r value of 46.4 k Ω is selected.

8.2.2.2.9 Secondary Diode

The reverse voltage across secondary-rectifier diode D1 when the high-side buck switch is off can be calculated using [Equation 31](#).

$$V_{D1} = \frac{N_2}{N_1} V_{IN} \quad (31)$$

For a V_{IN_MAX} of 95 V and the 1:1 turns ratio of this design, a 100 V Schottky is selected.

8.2.2.2.10 V_{CC} and Bootstrap Capacitor

A 1- μF capacitor of 16 V or higher rating is recommended for the V_{CC} regulator bypass capacitor.

A good value for the BST pin bootstrap capacitor is 0.01- μF with a 16 V or higher rating.

8.2.2.2.11 Input Capacitor

The input capacitor is typically a combination of a smaller bypass capacitor located near the regulator IC and a larger bulk capacitor. The total input capacitance should be large enough to limit the input voltage ripple to a desired amplitude. For input ripple voltage ΔV_{IN} , C_{IN} can be calculated using [Equation 32](#).

$$C_{IN} \geq \frac{I_{OUT(MAX)}}{4 \times f \times \Delta V_{IN}} \quad (32)$$

Choosing a ΔV_{IN} of 0.5 V gives a minimum C_{IN} of 0.2 μF . A standard value of 0.47 μF is selected for C_{BYP} in this design. A bulk capacitor of higher value reduces voltage spikes due to parasitic inductance between the power source to the converter. A standard value of 2.2 μF is selected for C_{IN} in this design. The voltage ratings of the two input capacitors should be greater than the maximum input voltage under all conditions.

8.2.2.2.12 UVLO Resistors

UVLO resistors R_{UV1} and R_{UV2} set the undervoltage lockout threshold and hysteresis according to Equation 33 and Equation 34.

$$V_{IN(HYS)} = I_{HYS} \times R_{UV2} \tag{33}$$

$$V_{IN(UVLO, rising)} = 1.225V \times \left(\frac{R_{UV2}}{R_{UV1}} + 1 \right) \tag{34}$$

Where $I_{HYS} = 20 \mu A$, typical.

For a UVLO hysteresis of 2.5 V and UVLO rising threshold of 20 V, Equation 33 and Equation 34 require R_{UV1} of 8.25 k Ω and R_{UV2} of 127 k Ω and these values are selected for this design example.

8.2.2.2.13 V_{CC} Diode

Diode D2 is an optional diode connected between V_{OUT1} and the V_{CC} regulator output pin. When V_{OUT1} is more than one diode drop greater than the V_{CC} voltage, the V_{CC} bias current is supplied from V_{OUT1} . This results in reduced power losses in the internal V_{CC} regulator which improves converter efficiency. V_{OUT1} must be set to a voltage at least one diode drop higher than 8.55 V (the maximum V_{CC} voltage) if D2 is used to supply bias current.

8.2.2.3 Application Curves

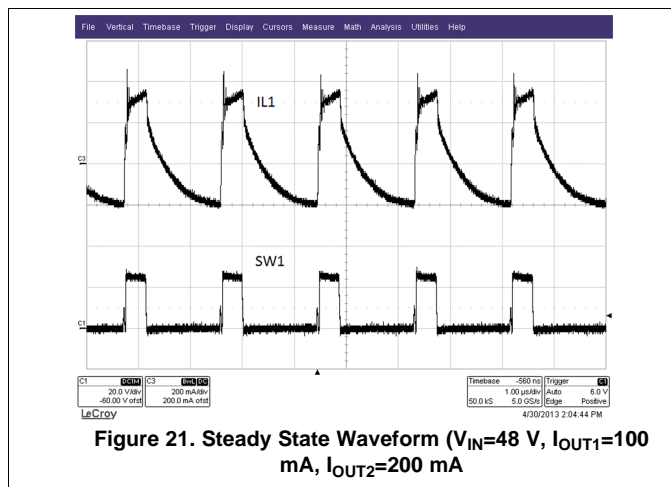

Figure 21. Steady State Waveform ($V_{IN}=48V$, $I_{OUT1}=100mA$, $I_{OUT2}=200mA$)

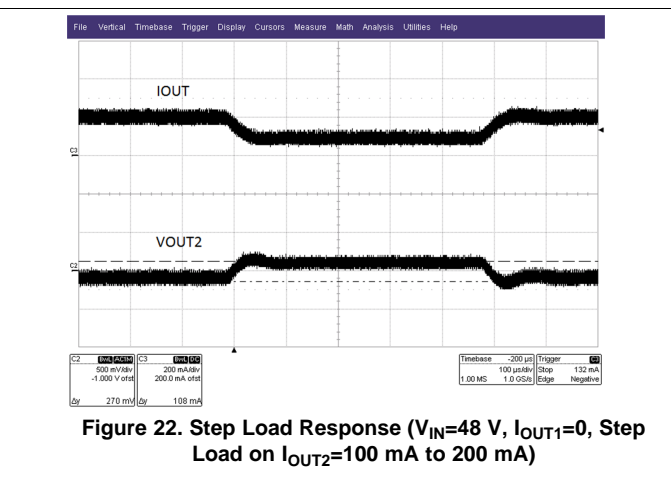

Figure 22. Step Load Response ($V_{IN}=48V$, $I_{OUT1}=0$, Step Load on $I_{OUT2}=100mA$ to $200mA$)

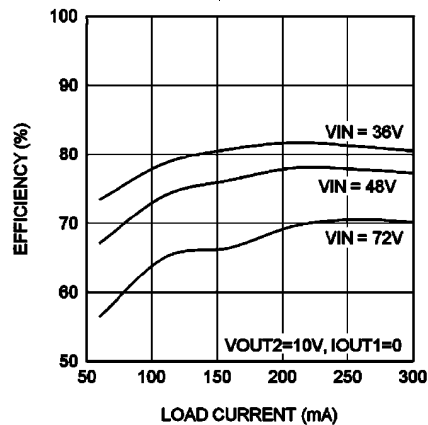

Figure 23. Efficiency at 750 kHz, $V_{OUT1}=10V$

9 Power Supply Recommendations

LM5017 is a power management device. The power supply for the device is any dc voltage source within the specified input range.

10 Layout

10.1 Layout Guidelines

A proper layout is essential for optimum performance of the circuit. In particular, the following guidelines should be observed:

1. C_{IN} : The loop consisting of input capacitor (C_{IN}), V_{IN} pin, and RTN pin carries switching currents. Therefore, the input capacitor should be placed close to the IC, directly across V_{IN} and RTN pins and the connections to these two pins should be direct to minimize the loop area. In general it is not possible to accommodate all of input capacitance near the IC. A good practice is to use a 0.1- μF or 0.47- μF capacitor directly across the V_{IN} and RTN pins close to the IC, and the remaining bulk capacitor as close as possible (see [Figure 24](#)).
2. C_{VCC} and C_{BST} : The V_{CC} and bootstrap (BST) bypass capacitors supply switching currents to the high and low side gate drivers. These two capacitors should also be placed as close to the IC as possible, and the connecting trace length and loop area should be minimized (see [Figure 24](#)).
3. The Feedback trace carries the output voltage information and a small ripple component that is necessary for proper operation of LM5017. Therefore, care should be taken while routing the feedback trace to avoid coupling any noise to this pin. In particular, feedback trace should not run close to magnetic components, or parallel to any other switching trace.
4. SW trace: The SW node switches rapidly between V_{IN} and GND every cycle and is therefore a possible source of noise. The SW node area should be minimized. In particular, the SW node should not be inadvertently connected to a copper plane or pour.

10.2 Layout Example

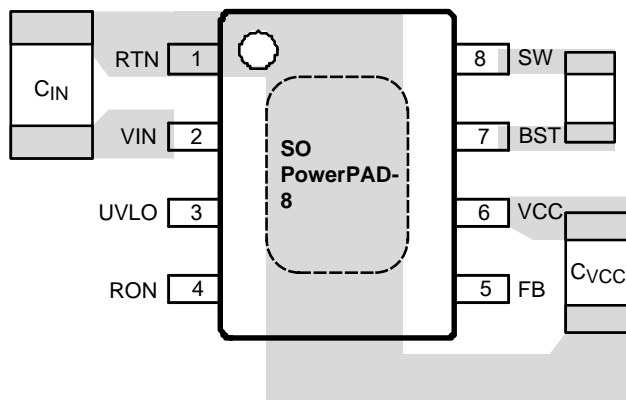

Figure 24. Placement of Bypass Capacitors

11 Device and Documentation Support

11.1 Documentation Support

11.1.1 Related Documentation

- *Absolute Maximum Ratings for Soldering* ([SNOA549](#))
- *AN-2204 LM5017 Isolated Supply Evaluation Board* ([SNVA611](#))
- *AN-1481 Controlling Output Ripple and Achieving ESR Independence in Constant On-Time (COT) Regulator Designs* ([SNVA166](#))

11.2 Trademarks

PowerPAD, Fly-Buck are trademarks of Texas Instruments.
WEBENCH is a registered trademark of Texas Instruments.
All other trademarks are the property of their respective owners.

11.3 Electrostatic Discharge Caution



These devices have limited built-in ESD protection. The leads should be shorted together or the device placed in conductive foam during storage or handling to prevent electrostatic damage to the MOS gates.

11.4 Glossary

[SLYZ022](#) — *TI Glossary*.

This glossary lists and explains terms, acronyms, and definitions.

12 Mechanical, Packaging, and Orderable Information

The following pages include mechanical, packaging, and orderable information. This information is the most current data available for the designated devices. This data is subject to change without notice and revision of this document. For browser-based versions of this data sheet, refer to the left-hand navigation.

PACKAGING INFORMATION

Orderable Device	Status (1)	Package Type	Package Drawing	Pins	Package Qty	Eco Plan (2)	Lead/Ball Finish (6)	MSL Peak Temp (3)	Op Temp (°C)	Device Marking (4/5)	Samples
LM5017MR/NOPB	ACTIVE	SO PowerPAD	DDA	8	95	Green (RoHS & no Sb/Br)	CU SN	Level-3-260C-168 HR		L5017 MR	Samples
LM5017MRE/NOPB	ACTIVE	SO PowerPAD	DDA	8	250	Green (RoHS & no Sb/Br)	CU SN	Level-3-260C-168 HR		L5017 MR	Samples
LM5017MRX/NOPB	ACTIVE	SO PowerPAD	DDA	8	2500	Green (RoHS & no Sb/Br)	CU SN	Level-3-260C-168 HR		L5017 MR	Samples
LM5017SD/NOPB	ACTIVE	WSON	NGU	8	1000	Green (RoHS & no Sb/Br)	CU SN	Level-1-260C-UNLIM		L5017	Samples
LM5017SDX/NOPB	ACTIVE	WSON	NGU	8	4500	Green (RoHS & no Sb/Br)	CU SN	Level-1-260C-UNLIM		L5017	Samples

(1) The marketing status values are defined as follows:

ACTIVE: Product device recommended for new designs.

LIFEBUY: TI has announced that the device will be discontinued, and a lifetime-buy period is in effect.

NRND: Not recommended for new designs. Device is in production to support existing customers, but TI does not recommend using this part in a new design.

PREVIEW: Device has been announced but is not in production. Samples may or may not be available.

OBSOLETE: TI has discontinued the production of the device.

(2) Eco Plan - The planned eco-friendly classification: Pb-Free (RoHS), Pb-Free (RoHS Exempt), or Green (RoHS & no Sb/Br) - please check <http://www.ti.com/productcontent> for the latest availability information and additional product content details.

TBD: The Pb-Free/Green conversion plan has not been defined.

Pb-Free (RoHS): TI's terms "Lead-Free" or "Pb-Free" mean semiconductor products that are compatible with the current RoHS requirements for all 6 substances, including the requirement that lead not exceed 0.1% by weight in homogeneous materials. Where designed to be soldered at high temperatures, TI Pb-Free products are suitable for use in specified lead-free processes.

Pb-Free (RoHS Exempt): This component has a RoHS exemption for either 1) lead-based flip-chip solder bumps used between the die and package, or 2) lead-based die adhesive used between the die and leadframe. The component is otherwise considered Pb-Free (RoHS compatible) as defined above.

Green (RoHS & no Sb/Br): TI defines "Green" to mean Pb-Free (RoHS compatible), and free of Bromine (Br) and Antimony (Sb) based flame retardants (Br or Sb do not exceed 0.1% by weight in homogeneous material)

(3) MSL, Peak Temp. - The Moisture Sensitivity Level rating according to the JEDEC industry standard classifications, and peak solder temperature.

(4) There may be additional marking, which relates to the logo, the lot trace code information, or the environmental category on the device.

(5) Multiple Device Markings will be inside parentheses. Only one Device Marking contained in parentheses and separated by a "~" will appear on a device. If a line is indented then it is a continuation of the previous line and the two combined represent the entire Device Marking for that device.

⁽⁶⁾ Lead/Ball Finish - Orderable Devices may have multiple material finish options. Finish options are separated by a vertical ruled line. Lead/Ball Finish values may wrap to two lines if the finish value exceeds the maximum column width.

Important Information and Disclaimer:The information provided on this page represents TI's knowledge and belief as of the date that it is provided. TI bases its knowledge and belief on information provided by third parties, and makes no representation or warranty as to the accuracy of such information. Efforts are underway to better integrate information from third parties. TI has taken and continues to take reasonable steps to provide representative and accurate information but may not have conducted destructive testing or chemical analysis on incoming materials and chemicals. TI and TI suppliers consider certain information to be proprietary, and thus CAS numbers and other limited information may not be available for release.

In no event shall TI's liability arising out of such information exceed the total purchase price of the TI part(s) at issue in this document sold by TI to Customer on an annual basis.

TAPE AND REEL INFORMATION



QUADRANT ASSIGNMENTS FOR PIN 1 ORIENTATION IN TAPE



*All dimensions are nominal

Device	Package Type	Package Drawing	Pins	SPQ	Reel Diameter (mm)	Reel Width W1 (mm)	A0 (mm)	B0 (mm)	K0 (mm)	P1 (mm)	W (mm)	Pin1 Quadrant
LM5017MRE/NOPB	SO Power PAD	DDA	8	250	178.0	12.4	6.5	5.4	2.0	8.0	12.0	Q1
LM5017MRX/NOPB	SO Power PAD	DDA	8	2500	330.0	12.4	6.5	5.4	2.0	8.0	12.0	Q1
LM5017SD/NOPB	WSO	NGU	8	1000	178.0	12.4	4.3	4.3	1.3	8.0	12.0	Q1
LM5017SDX/NOPB	WSO	NGU	8	4500	330.0	12.4	4.3	4.3	1.3	8.0	12.0	Q1

TAPE AND REEL BOX DIMENSIONS



*All dimensions are nominal

Device	Package Type	Package Drawing	Pins	SPQ	Length (mm)	Width (mm)	Height (mm)
LM5017MRE/NOPB	SO PowerPAD	DDA	8	250	213.0	191.0	55.0
LM5017MRX/NOPB	SO PowerPAD	DDA	8	2500	367.0	367.0	35.0
LM5017SD/NOPB	WSON	NGU	8	1000	210.0	185.0	35.0
LM5017SDX/NOPB	WSON	NGU	8	4500	367.0	367.0	35.0

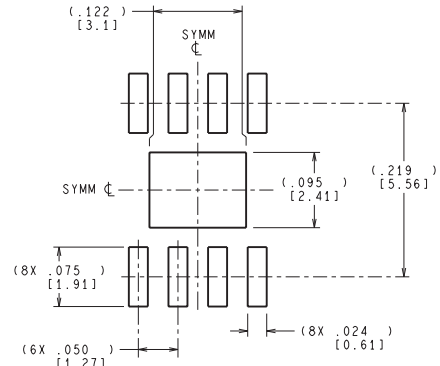
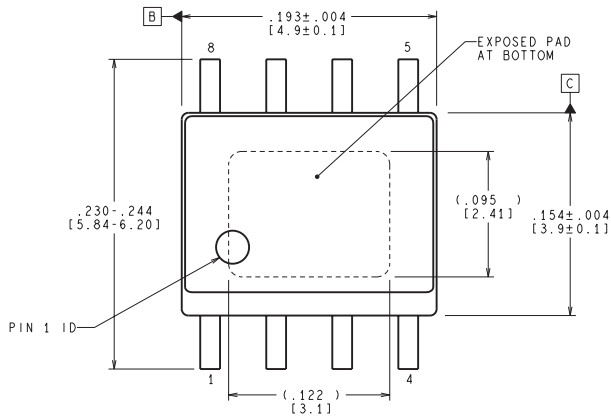
DDA0008B

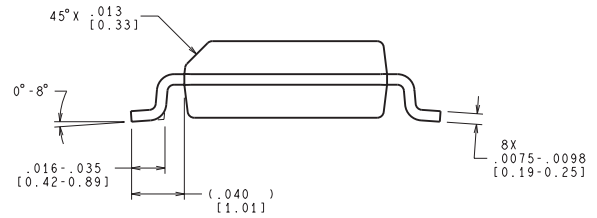
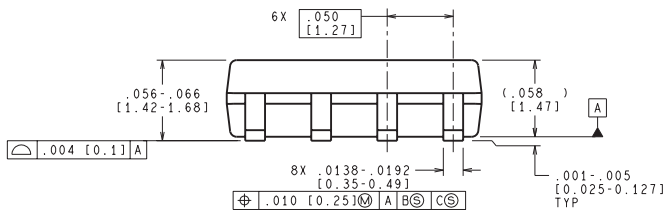

RECOMMENDED LAND PATTERN



CONTROLLING DIMENSION IS INCH
VALUES IN [] ARE MILLIMETERS
DIMENSIONS IN () FOR REFERENCE ONLY

MRA08B (Rev B)

NGU0008B

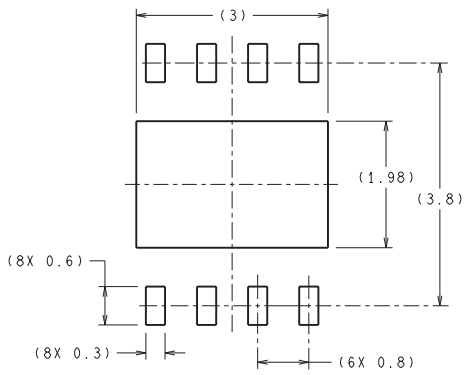

RECOMMENDED LAND PATTERN

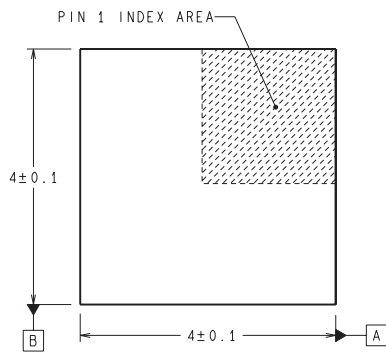

DIMENSIONS ARE IN MILLIMETERS
DIMENSIONS IN () FOR REFERENCE ONLY

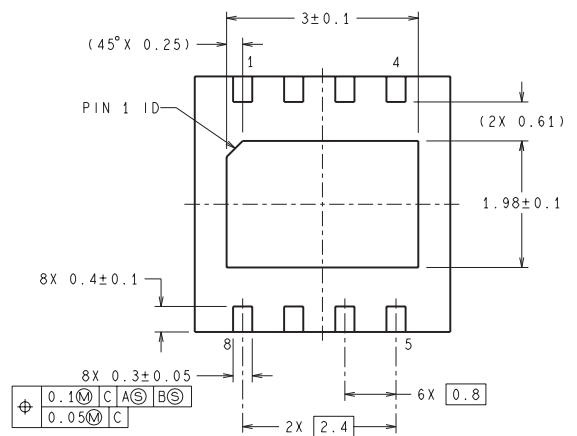
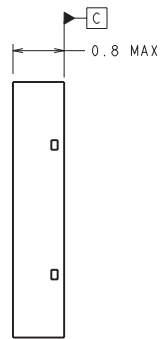

SDC08B (Rev A)

IMPORTANT NOTICE

Texas Instruments Incorporated and its subsidiaries (TI) reserve the right to make corrections, enhancements, improvements and other changes to its semiconductor products and services per JESD46, latest issue, and to discontinue any product or service per JESD48, latest issue. Buyers should obtain the latest relevant information before placing orders and should verify that such information is current and complete. All semiconductor products (also referred to herein as "components") are sold subject to TI's terms and conditions of sale supplied at the time of order acknowledgment.

TI warrants performance of its components to the specifications applicable at the time of sale, in accordance with the warranty in TI's terms and conditions of sale of semiconductor products. Testing and other quality control techniques are used to the extent TI deems necessary to support this warranty. Except where mandated by applicable law, testing of all parameters of each component is not necessarily performed.

TI assumes no liability for applications assistance or the design of Buyers' products. Buyers are responsible for their products and applications using TI components. To minimize the risks associated with Buyers' products and applications, Buyers should provide adequate design and operating safeguards.

TI does not warrant or represent that any license, either express or implied, is granted under any patent right, copyright, mask work right, or other intellectual property right relating to any combination, machine, or process in which TI components or services are used. Information published by TI regarding third-party products or services does not constitute a license to use such products or services or a warranty or endorsement thereof. Use of such information may require a license from a third party under the patents or other intellectual property of the third party, or a license from TI under the patents or other intellectual property of TI.

Reproduction of significant portions of TI information in TI data books or data sheets is permissible only if reproduction is without alteration and is accompanied by all associated warranties, conditions, limitations, and notices. TI is not responsible or liable for such altered documentation. Information of third parties may be subject to additional restrictions.

Resale of TI components or services with statements different from or beyond the parameters stated by TI for that component or service voids all express and any implied warranties for the associated TI component or service and is an unfair and deceptive business practice. TI is not responsible or liable for any such statements.

Buyer acknowledges and agrees that it is solely responsible for compliance with all legal, regulatory and safety-related requirements concerning its products, and any use of TI components in its applications, notwithstanding any applications-related information or support that may be provided by TI. Buyer represents and agrees that it has all the necessary expertise to create and implement safeguards which anticipate dangerous consequences of failures, monitor failures and their consequences, lessen the likelihood of failures that might cause harm and take appropriate remedial actions. Buyer will fully indemnify TI and its representatives against any damages arising out of the use of any TI components in safety-critical applications.

In some cases, TI components may be promoted specifically to facilitate safety-related applications. With such components, TI's goal is to help enable customers to design and create their own end-product solutions that meet applicable functional safety standards and requirements. Nonetheless, such components are subject to these terms.

No TI components are authorized for use in FDA Class III (or similar life-critical medical equipment) unless authorized officers of the parties have executed a special agreement specifically governing such use.

Only those TI components which TI has specifically designated as military grade or "enhanced plastic" are designed and intended for use in military/aerospace applications or environments. Buyer acknowledges and agrees that any military or aerospace use of TI components which have **not** been so designated is solely at the Buyer's risk, and that Buyer is solely responsible for compliance with all legal and regulatory requirements in connection with such use.

TI has specifically designated certain components as meeting ISO/TS16949 requirements, mainly for automotive use. In any case of use of non-designated products, TI will not be responsible for any failure to meet ISO/TS16949.

Products

Audio	www.ti.com/audio
Amplifiers	amplifier.ti.com
Data Converters	dataconverter.ti.com
DLP® Products	www.dlp.com
DSP	dsp.ti.com
Clocks and Timers	www.ti.com/clocks
Interface	interface.ti.com
Logic	logic.ti.com
Power Mgmt	power.ti.com
Microcontrollers	microcontroller.ti.com
RFID	www.ti-rfid.com
OMAP Applications Processors	www.ti.com/omap
Wireless Connectivity	www.ti.com/wirelessconnectivity

Applications

Automotive and Transportation	www.ti.com/automotive
Communications and Telecom	www.ti.com/communications
Computers and Peripherals	www.ti.com/computers
Consumer Electronics	www.ti.com/consumer-apps
Energy and Lighting	www.ti.com/energy
Industrial	www.ti.com/industrial
Medical	www.ti.com/medical
Security	www.ti.com/security
Space, Avionics and Defense	www.ti.com/space-avionics-defense
Video and Imaging	www.ti.com/video

TI E2E Community

e2e.ti.com

Looking for pricing, stock, or lifecycle information?

Click below to explore more details on WIN SOURCE:

 [View LM5017MRE/NOPB on WIN SOURCE](#)

 [Texas Instruments](#) Information

Optimize Your Supply Chain with WIN SOURCE Solutions

-  Global Sourcing Solution
-  Obsolete Management
-  Cost Control Management
-  Shortage Management
-  Alternative Solution
-  Excess Inventory Management