



THE DATASHEET OF LM5022MMX



LM5022 60-V Low-Side Controller for Boost and SEPIC

1 Features

- Internal 60-V Start-Up Regulator
- 1-A Peak MOSFET Gate Driver
- V_{IN} Range: 6 V to 60 V (Operates Down to 3 V After Start-Up)
- Duty Cycle Limit of 90%
- Programmable UVLO With Hysteresis
- Cycle-by-Cycle Current Limit
- External Synchronizable (AC-Coupled)
- Single Resistor Oscillator Frequency Set
- Slope Compensation
- Adjustable Soft Start
- 10-Pin VSSOP Package

2 Applications

- Boost Converters
- SEPIC Converters

3 Description

The LM5022 device is a high-voltage, low-side, N-channel MOSFET controller ideal for use in boost and SEPIC regulators. It contains all of the features required to implement single-ended primary topologies. Output voltage regulation is based on current-mode control, which eases the design of loop compensation while providing inherent input voltage feedforward. The LM5022 includes a start-up regulator that operates over a wide input range of 6 V to 60 V. The PWM controller is designed for high-speed capability including an oscillator frequency range up to 2.2 MHz and total propagation delays less than 100 ns. Additional features include an error amplifier, precision reference, line undervoltage lockout, cycle-by-cycle current limit, slope compensation, soft start, external synchronization capability, and thermal shutdown. The LM5022 is available in the 10-pin VSSOP package.

Device Information⁽¹⁾

PART NUMBER	PACKAGE	BODY SIZE (NOM)
LM5022	VSSOP (10)	3.00 mm x 3.00 mm

(1) For all available packages, see the orderable addendum at the end of the data sheet.

Typical Application

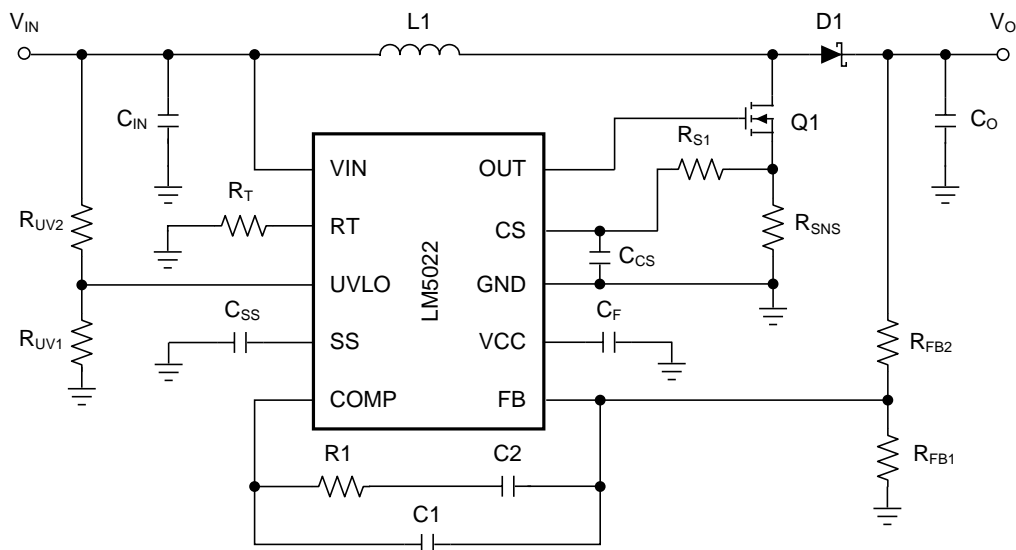

Copyright © 2016, Texas Instruments Incorporated



Table of Contents

1 Features	1	8 Application and Implementation	14
2 Applications	1	8.1 Application Information.....	14
3 Description	1	8.2 Typical Application	14
4 Revision History	2	9 Power Supply Recommendations	28
5 Pin Configuration and Functions	3	10 Layout	29
6 Specifications	4	10.1 Layout Guidelines	29
6.1 Absolute Maximum Ratings	4	10.2 Layout Examples.....	30
6.2 ESD Ratings	4	11 Device and Documentation Support	32
6.3 Recommended Operating Conditions.....	4	11.1 Device Support.....	32
6.4 Thermal Information	4	11.2 Documentation Support	32
6.5 Electrical Characteristics.....	5	11.3 Receiving Notification of Documentation Updates	32
6.6 Typical Characteristics	7	11.4 Community Resources.....	32
7 Detailed Description	9	11.5 Trademarks	32
7.1 Overview	9	11.6 Electrostatic Discharge Caution.....	32
7.2 Functional Block Diagram	9	11.7 Glossary	32
7.3 Feature Description.....	10	12 Mechanical, Packaging, and Orderable	32
7.4 Device Functional Modes.....	12	Information	32

4 Revision History

NOTE: Page numbers for previous revisions may differ from page numbers in the current version.

Changes from Revision H (December 2016) to Revision I Page

- Changed 1 To: C2 in [Equation 55](#)..... 24

Changes from Revision G (December 2013) to Revision H Page

- Added *ESD Ratings* table, *Feature Description* section, *Device Functional Modes*, *Application and Implementation* section, *Power Supply Recommendations* section, *Layout* section, *Device and Documentation Support* section, and *Mechanical, Packaging, and Orderable Information* section..... 1
- Deleted soldering temperature (215°C Vapor phase maximum and 220°C Infrared maximum)..... 4
- Changed Junction to Ambient Thermal Resistance, $R_{\theta JA}$, value From: 200 To: 161.5..... 4
- Changed slope compensation amplitude, V_{SLOPE} , values From: 80 To: 83 (Minimum), From: 105 To: 110 (Typical), and From: 130 To: 137 (Maximum)..... 5

Changes from Revision F (March 2013) to Revision G Page

- Changed timing resistor equation. Incorrect change when converting to TI format..... 12

Changes from Revision E (March 2013) to Revision F Page

- Changed layout of National Semiconductor Data Sheet to TI format

5 Pin Configuration and Functions

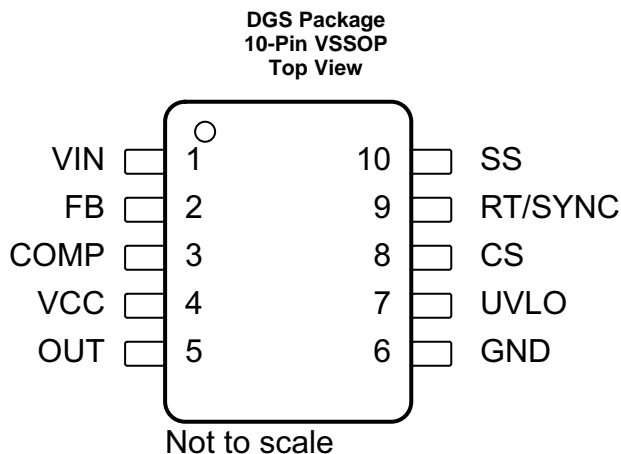

Pin Functions

PIN		I/O	DESCRIPTION
NO.	NAME		
1	VIN	I	Source input voltage: Input to the startup regulator. Operates from 6 V to 60 V.
2	FB	I	Feedback pin: Inverting input to the internal voltage error amplifier. The noninverting input of the error amplifier connects to a 1.25-V reference.
3	COMP	I/O	Error amplifier output and PWM comparator input: The control loop compensation components connect between this pin and the FB pin.
4	VCC	O	Output of the internal, high-voltage linear regulator: This pin must be bypassed to the GND pin with a ceramic capacitor.
5	OUT	O	Output of MOSFET gate driver: Connect this pin to the gate of the external MOSFET. The gate driver has a 1-A peak current capability.
6	GND	—	System ground
7	UVLO	I	Input undervoltage lockout: Set the start-up and shutdown levels by connecting this pin to the input voltage through a resistor divider. A 20- μ A current source provides hysteresis.
8	CS	I	Current sense input: Input for the switch current used for current mode control and for current limiting.
9	RT/SYNC	I	Oscillator frequency adjust pin and synchronization input: An external resistor connected from this pin to GND sets the oscillator frequency. This pin can also accept an AC-coupled input for synchronization from an external clock.
10	SS	I	Soft-start pin: An external capacitor placed from this pin to ground is charged by a 10- μ A current source, creating a ramp voltage to control the regulator start-up.

6 Specifications

6.1 Absolute Maximum Ratings

over operating free-air temperature range (unless otherwise noted)⁽¹⁾⁽²⁾

	MIN	MAX	UNIT
VIN to GND	-0.3	65	V
VCC to GND	-0.3	16	V
RT/SYNC to GND	-0.3	5.5	V
OUT to GND	-1.5 for < 100 ns		V
All other pins to GND	-0.3	7	V
Power dissipation	Internally limited		
Junction temperature, T _J ⁽³⁾		150	°C
Storage temperature, T _{stg}	-65	150	°C

- Stresses beyond those listed under *Absolute Maximum Ratings* may cause permanent damage to the device. These are stress ratings only, which do not imply functional operation of the device at these or any other conditions beyond those indicated under *Recommended Operating Conditions*. Exposure to absolute-maximum-rated conditions for extended periods may affect device reliability.
- If Military/Aerospace specified devices are required, contact the Texas Instruments Sales Office/ Distributors for availability and specifications.
- High junction temperatures degrade operating lifetimes. Operating lifetime is derated for junction temperatures greater than 125°C.

6.2 ESD Ratings

		VALUE	UNIT
V _(ESD) Electrostatic discharge	Human-body model (HBM), per ANSI/ESDA/JEDEC JS-001 ⁽¹⁾⁽²⁾	±2000	V
	Charged-device model (CDM), per JEDEC specification JESD22-C101 ⁽³⁾	±750	

- JEDEC document JEP155 states that 500-V HBM allows safe manufacturing with a standard ESD control process.
- The human-body model is a 100-pF capacitor discharged through a 1.5-kΩ resistor into each pin.
- JEDEC document JEP157 states that 250-V CDM allows safe manufacturing with a standard ESD control process.

6.3 Recommended Operating Conditions

over operating free-air temperature range (unless otherwise noted)⁽¹⁾

	MIN	MAX	UNIT
Supply voltage	6	60	V
External voltage at V _{CC}	7.5	14	V
Junction temperature	-40	125	°C

- Device thermal limitations may limit usable range

6.4 Thermal Information

THERMAL METRIC ⁽¹⁾	LM5022	UNIT
	DGS (VSSOP)	
	10 PINS	
R _{θJA} Junction-to-ambient thermal resistance	161.5	°C/W
R _{θJC(top)} Junction-to-case (top) thermal resistance	56	°C/W
R _{θJB} Junction-to-board thermal resistance	81.3	°C/W
ψ _{JT} Junction-to-top characterization parameter	5.7	°C/W
ψ _{JB} Junction-to-board characterization parameter	80	°C/W
R _{θJC(bot)} Junction-to-case (bottom) thermal resistance	—	°C/W

- For more information about traditional and new thermal metrics, see the [Semiconductor and IC Package Thermal Metrics](#) application report.

6.5 Electrical Characteristics

Typical limits apply for $T_J=25^\circ\text{C}$ and are provided for reference purposes only; minimum and maximum limits apply over the junction temperature (T_J) range of -40°C to 125°C . $V_{IN} = 24\text{ V}$ and $R_T = 27.4\text{ k}\Omega$ (unless otherwise noted).⁽¹⁾

PARAMETER		TEST CONDITIONS	MIN	TYP	MAX	UNIT
SYSTEM PARAMETERS						
V_{FB}	FB pin voltage		1.225	1.25	1.275	V
STARTUP REGULATOR						
V_{CC}	VCC regulation ⁽²⁾	$10\text{ V} \leq V_{IN} \leq 60\text{ V}$, $I_{CC} = 1\text{ mA}$	6.6	7	7.4	V
		$6\text{ V} \leq V_{IN} < 10\text{ V}$, VCC Pin Open Circuit	5			
I_{CC}	Supply current	OUT Pin Capacitance = 0, VCC = 10 V		3.5	4	mA
I_{CC-LIM}	VCC current limit	VCC = 0 V ⁽²⁾⁽³⁾	15	35		mA
$V_{IN} - V_{CC}$	Dropout voltage across bypass switch	$I_{CC} = 0\text{ mA}$, $f_{SW} < 200\text{ kHz}$, $6\text{ V} \leq V_{IN} \leq 8.5\text{ V}$		200		mV
V_{BYP-HI}	Bypass switch turnoff threshold	V_{IN} increasing		8.7		V
$V_{BYP-HYS}$	Bypass switch threshold hysteresis	V_{IN} Decreasing		260		mV
Z_{VCC}	VCC pin output impedance $0\text{ mA} \leq I_{CC} \leq 5\text{ mA}$	$V_{IN} = 6\text{ V}$		58		Ω
		$V_{IN} = 8\text{ V}$		53		
		$V_{IN} = 24\text{ V}$		1.6		
V_{CC-HI}	VCC pin UVLO rising threshold			5		V
V_{CC-HYS}	VCC pin UVLO falling hysteresis			300		mV
I_{VIN}	Startup regulator leakage	$V_{IN} = 60\text{ V}$		150	500	μA
I_{IN-SD}	Shutdown current	$V_{UVLO} = 0\text{ V}$, VCC = Open Circuit		350	450	μA
ERROR AMPLIFIER						
GBW	Gain bandwidth			4		MHz
A_{DC}	DC gain			75		dB
I_{COMP}	COMP pin current sink capability	$V_{FB} = 1.5\text{ V}$, $V_{COMP} = 1\text{ V}$	5	17		mA
UVLO						
V_{SD}	Shutdown threshold		1.22	1.25	1.28	V
I_{SD-HYS}	Shutdown hysteresis current source		16	20	24	μA
CURRENT LIMIT						
$t_{LIM-DLY}$	Delay from ILIM to output	CS steps from 0 V to 0.6 V, OUT transitions to 90% of VCC		30		ns
V_{CS}	Current limit threshold voltage		0.45	0.5	0.55	V
t_{BLK}	Leading edge blanking time			65		ns
R_{CS}	CS pin sink impedance	Blanking active		40	75	Ω
SOFT START						
I_{SS}	Soft-start current source		7	10	13	μA
V_{SS-OFF}	Soft start to COMP offset		0.35	0.55	0.75	V

(1) All Minimum and Maximum limits are specified by correlating the electrical characteristics to process and temperature variations and applying statistical process control. The junction temperature (T_J in $^\circ\text{C}$) is calculated from the ambient temperature (T_A in $^\circ\text{C}$) and power dissipation (P_D in Watts) as follows: $T_J = T_A + (P_D \times R_{\theta JA})$ where $R_{\theta JA}$ (in $^\circ\text{C}/\text{W}$) is the package thermal impedance provided in [Thermal Information](#).

(2) VCC provides bias for the internal gate drive and control circuits.

(3) Device thermal limitations may limit usable range.

Electrical Characteristics (continued)

Typical limits apply for $T_J=25^{\circ}\text{C}$ and are provided for reference purposes only; minimum and maximum limits apply over the junction temperature (T_J) range of -40°C to 125°C . $V_{IN} = 24\text{ V}$ and $R_T = 27.4\text{ k}\Omega$ (unless otherwise noted).⁽¹⁾

PARAMETER		TEST CONDITIONS	MIN	TYP	MAX	UNIT
OSCILLATOR						
f_{SW}	RT to GND = 84.5 k Ω		170 ⁽⁴⁾	200	230	kHz
	RT to GND = 27.4 k Ω	See ⁽⁴⁾	525	600	675	kHz
	RT to GND = 16.2 k Ω	See ⁽⁴⁾	865	990	1115	kHz
$V_{\text{SYNC-HI}}$	Synchronization rising threshold				3.8	V
PWM COMPARATOR						
$t_{\text{COMP-DLY}}$	Delay from COMP to OUT transition	$V_{\text{COMP}} = 2\text{ V}$, CS stepped from 0 V to 0.4 V		25		ns
D_{MIN}	Minimum duty cycle	$V_{\text{COMP}} = 0\text{ V}$			0%	
D_{MAX}	Maximum duty cycle		90%	95%		
A_{PWM}	COMP to PWM comparator gain			0.33		V/V
$V_{\text{COMP-OC}}$	COMP pin open circuit voltage	$V_{\text{FB}} = 0\text{ V}$	4.3	5.2	6.1	V
$I_{\text{COMP-SC}}$	COMP pin short circuit current	$V_{\text{COMP}} = 0\text{ V}$, $V_{\text{FB}} = 1.5\text{ V}$	0.6	1.1	1.5	mA
SLOPE COMPENSATION						
V_{SLOPE}	Slope compensation amplitude		83	110	137	mV
MOSFET DRIVER						
$V_{\text{SAT-HI}}$	Output high saturation voltage ($V_{\text{CC}} - V_{\text{OUT}}$)	$I_{\text{OUT}} = 50\text{ mA}$		0.25	0.75	V
$V_{\text{SAT-LO}}$	Output low saturation voltage (V_{OUT})	$I_{\text{OUT}} = 100\text{ mA}$		0.25	0.75	V
t_{RISE}	OUT pin rise time	OUT Pin load = 1 nF		18		ns
t_{FALL}	OUT pin fall time	OUT Pin load = 1 nF		15		ns
THERMAL CHARACTERISTICS						
T_{SD}	Thermal shutdown threshold			165		$^{\circ}\text{C}$
$T_{\text{SD-HYS}}$	Thermal shutdown hysteresis			25		$^{\circ}\text{C}$

(4) Specification applies to the oscillator frequency.

6.6 Typical Characteristics

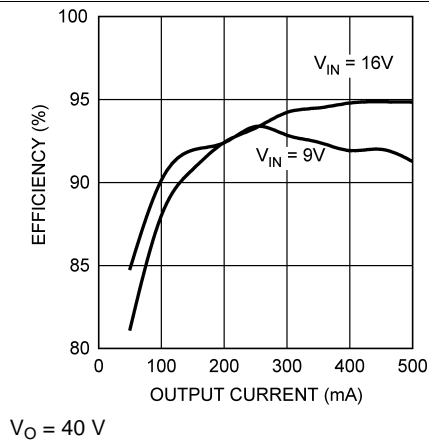

Figure 1. Efficiency, Example Circuit BOM

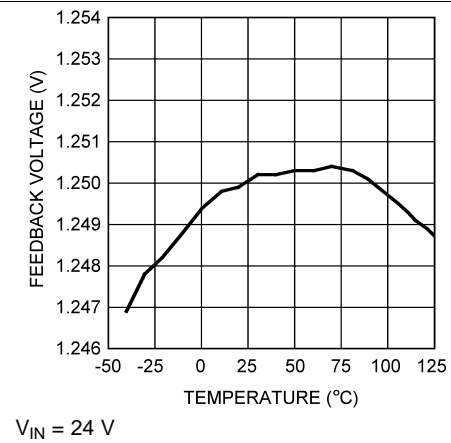

Figure 2. V_{FB} vs Temperature

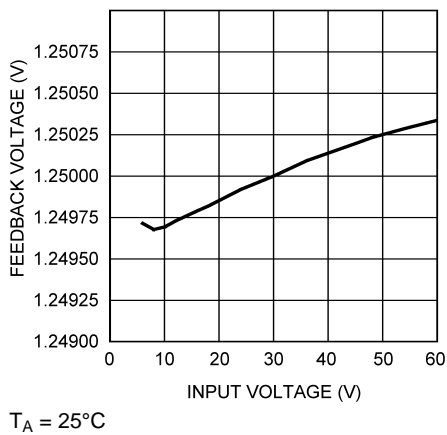

Figure 3. V_{FB} vs V_{IN}

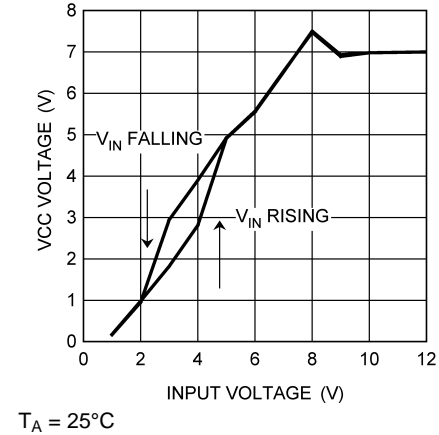

Figure 4. V_{CC} vs V_{IN}

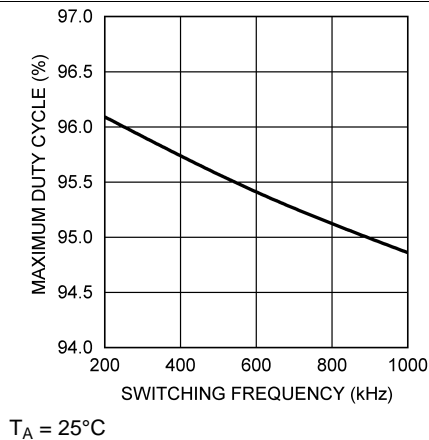

Figure 5. Maximum Duty Cycle vs f_{sw}

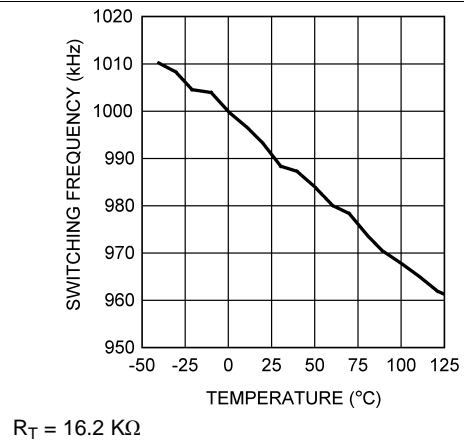

Figure 6. f_{sw} vs Temperature

Typical Characteristics (continued)

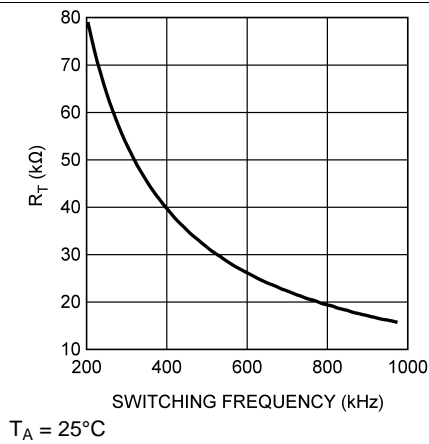

Figure 7. R_T vs f_{sw}

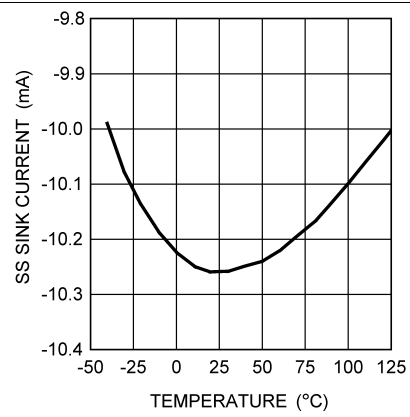

Figure 8. SS vs Temperature

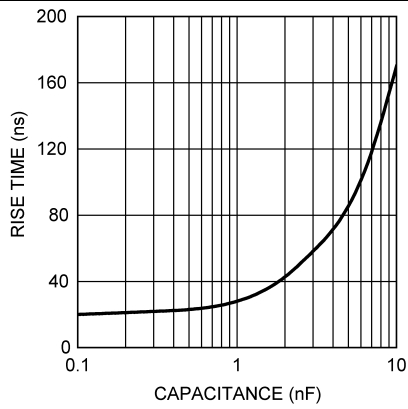

Figure 9. OUT Pin T_{RISE} vs Gate Capacitance

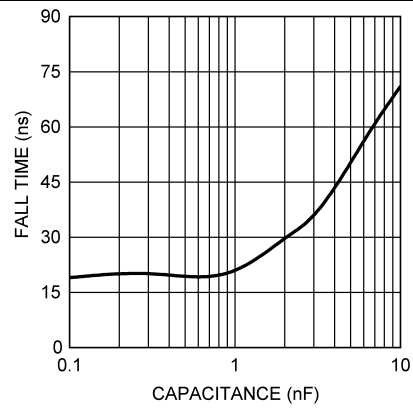

Figure 10. OUT Pin T_{FALL} vs Gate Capacitance

7 Detailed Description

7.1 Overview

The LM5022 is a low-side, N-channel MOSFET controller that contains all of the features required to implement single-ended power converter topologies. The LM5022 includes a high-voltage start-up regulator that operates over a wide input range of 6 V to 60 V. The PWM controller is designed for high-speed capability including an oscillator frequency range up to 2.2 MHz and total propagation delays less than 100 ns. Additional features include an error amplifier, precision reference, input undervoltage lockout, cycle-by-cycle current limit, slope compensation, soft start, oscillator sync capability, and thermal shutdown.

The LM5022 is designed for current-mode control power converters that require a single drive output, such as boost and SEPIC topologies. The LM5022 provides all of the advantages of current-mode control including input voltage feedforward, cycle-by-cycle current limiting, and simplified loop compensation.

7.2 Functional Block Diagram

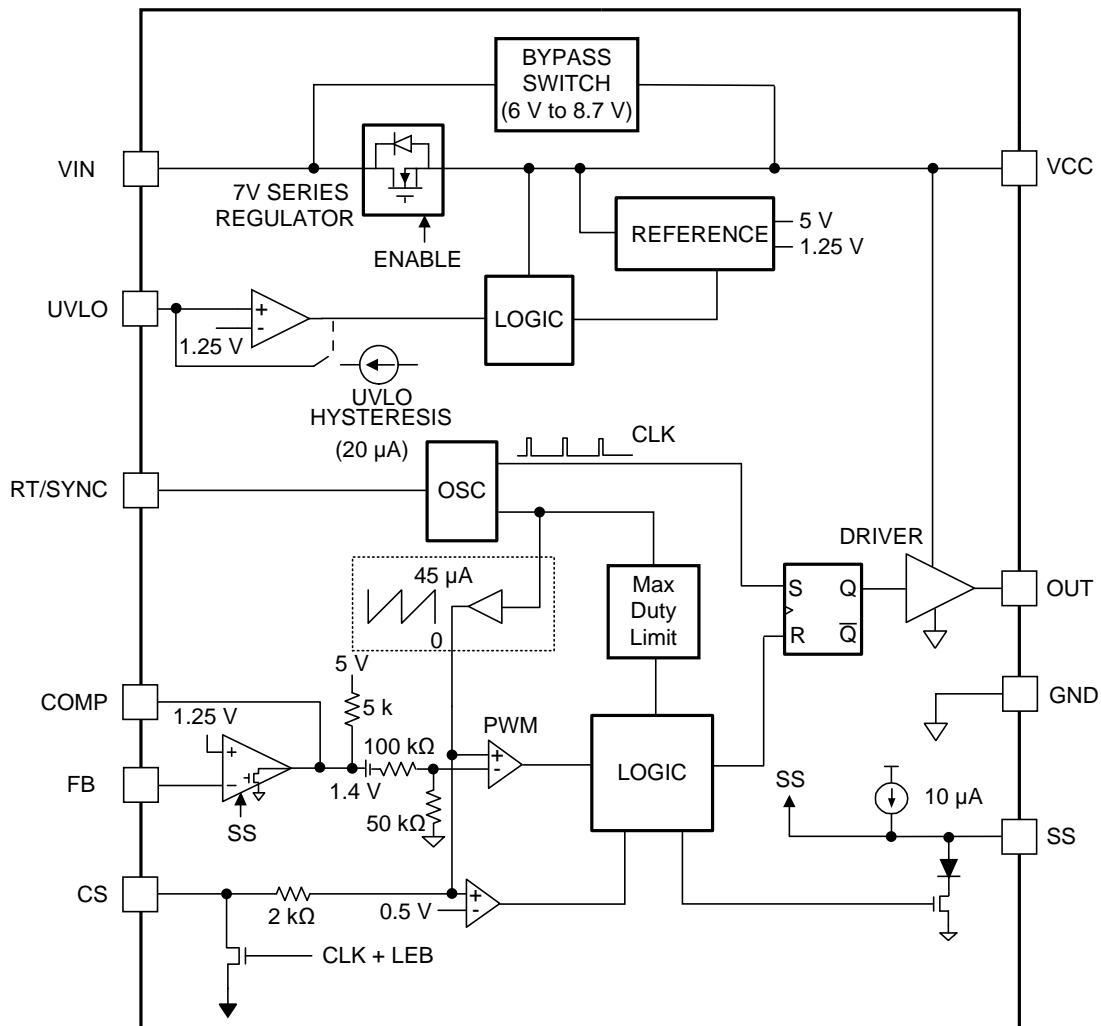

Copyright © 2016, Texas Instruments Incorporated

7.3 Feature Description

7.3.1 High-Voltage Start-Up Regulator

The LM5022 contains an internal high-voltage start-up regulator that allows the VIN pin to be connected directly to line voltages as high as 60 V. The regulator output is internally current limited to 35 mA (typical). When power is applied, the regulator is enabled and sources current into an external capacitor, C_F , connected to the VCC pin. The recommended capacitance range for C_F is 0.1 μF to 100 μF . When the voltage on the VCC pin reaches the rising threshold of 5 V, the controller output is enabled. The controller remains enabled until VCC falls below 4.7 V. In applications using a transformer, an auxiliary winding can be connected through a diode to the VCC pin. This winding must raise the VCC pin voltage to above 7.5 V to shut off the internal start-up regulator. Powering VCC from an auxiliary winding improves conversion efficiency while reducing the power dissipated in the controller. The capacitance of C_F must be high enough that it maintains the VCC voltage greater than the VCC UVLO falling threshold (4.7 V) during the initial start-up. During a fault condition when the converter auxiliary winding is inactive, external current draw on the VCC line must be limited such that the power dissipated in the start-up regulator does not exceed the maximum power dissipation capability of the controller.

An external start-up or other bias rail can be used instead of the internal start-up regulator by connecting the VCC and the VIN pins together and feeding the external bias voltage (7.5 V to 14 V) to the two pins.

7.3.2 Input Undervoltage Detector

The LM5022 contains an input undervoltage lockout (UVLO) circuit. UVLO is programmed by connecting the UVLO pin to the center point of an external voltage divider from VIN to GND. The resistor divider must be designed such that the voltage at the UVLO pin is greater than 1.25 V when V_{IN} is in the desired operating range. If the undervoltage threshold is not met, all functions of the controller are disabled and the controller remains in a low power standby state. UVLO hysteresis is accomplished with an internal 20- μA current source that is switched on or off into the impedance of the setpoint divider. When the UVLO threshold is exceeded, the current source is activated to instantly raise the voltage at the UVLO pin. When the UVLO pin voltage falls below the 1.25-V threshold the current source is turned off, causing the voltage at the UVLO pin to fall. The UVLO pin can also be used to implement a remote enable or disable function. If an external transistor pulls the UVLO pin below the 1.25-V threshold, the converter is disabled. This external shutdown method is shown in [Figure 11](#).

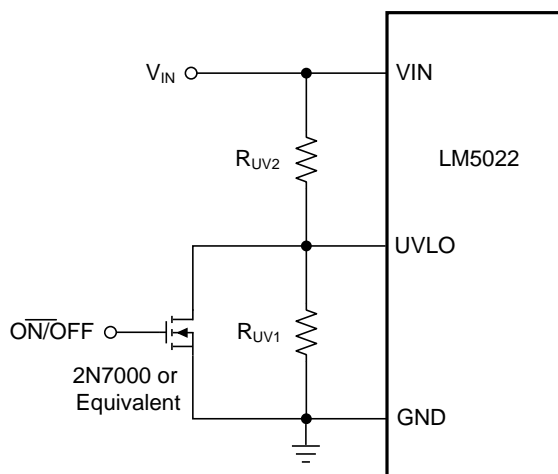

Copyright © 2016, Texas Instruments Incorporated

Figure 11. Enable or Disable Using UVLO

Feature Description (continued)

7.3.3 Error Amplifier

An internal high gain error amplifier is provided within the LM5022. The amplifier's noninverting input is internally set to a fixed reference voltage of 1.25 V. The inverting input is connected to the FB pin. In non-isolated applications such as the boost converter the output voltage, V_O , is connected to the FB pin through a resistor divider. The control loop compensation components are connected between the COMP and FB pins. For most isolated applications, the error amplifier function is implemented on the secondary side of the converter and the internal error amplifier is not used. The internal error amplifier is configured as an open-drain output and can be disabled by connecting the FB pin to ground. An internal 5-k Ω pullup resistor between a 5-V reference and COMP can be used as the pullup for an opto-coupler in isolated applications.

7.3.4 Current Sensing and Current Limiting

The LM5022 provides a cycle-by-cycle over current protection function. Current limit is accomplished by an internal current sense comparator. If the voltage at the current sense comparator input exceeds 0.5 V, the MOSFET gate drive is immediately terminated. A small RC filter, placed near the controller, is recommended to filter noise from the current sense signal. The CS input has an internal MOSFET which discharges the CS pin capacitance at the conclusion of every cycle. The discharge device remains on an additional 65 ns after the beginning of the new cycle to attenuate leading edge ringing on the current sense signal.

The LM5022 current sense and PWM comparators are very fast, and may respond to short duration noise pulses. Layout considerations are critical for the current sense filter and sense resistor. The capacitor associated with the CS filter must be placed very close to the device and connected directly to the pins of the controller (CS and GND). If a current sense transformer is used, both leads of the transformer secondary must be routed to the sense resistor and the current sense filter network. The current sense resistor can be placed between the source of the primary power MOSFET and power ground, but it must be a low inductance type. When designing with a current sense resistor all of the noise sensitive low-power ground connections must be connected together locally to the controller and a single connection must be made to the high current power ground (sense resistor ground point).

7.3.5 PWM Comparator and Slope Compensation

The PWM comparator compares the current ramp signal with the error voltage derived from the error amplifier output. The error amplifier output voltage at the COMP pin is offset by 1.4 V and then further attenuated by a 3:1 resistor divider. The PWM comparator polarity is such that 0 V on the COMP pin results in a zero duty cycle at the controller output. For duty cycles greater than 50%, current mode control circuits can experience sub-harmonic oscillation. By adding an additional fixed-slope voltage ramp signal (slope compensation) this oscillation can be avoided. Proper slope compensation damps the double pole associated with current mode control (see [Control Loop Compensation](#)) and eases the design of the control loop compensator. The LM5022 generates the slope compensation with a sawtooth-waveform current source with a slope of $45 \mu\text{A} \times f_{\text{SW}}$, generated by the clock (see [Figure 12](#)). This current flows through an internal 2-k Ω resistor to create a minimum compensation ramp with a slope of $100 \text{ mV} \times f_{\text{SW}}$ (typical). The slope of the compensation ramp increases when external resistance is added for filtering the current sense (R_{S1}) or in the position R_{S2} . As shown in [Figure 12](#) and the [Functional Block Diagram](#), the sensed current slope and the compensation slope add together to create the signal used for current limiting and for the control loop itself.

Feature Description (continued)

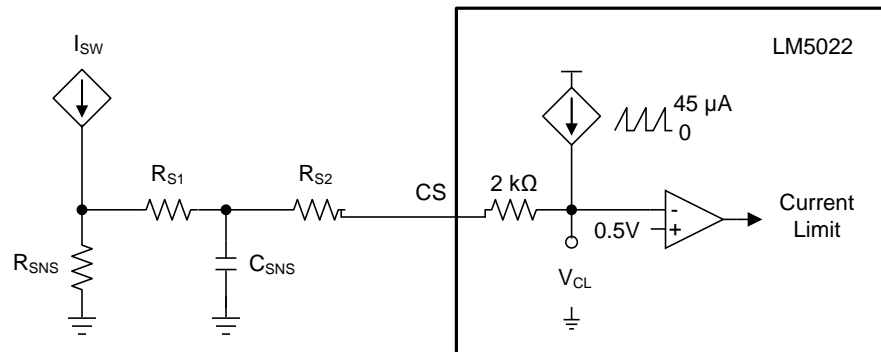

Copyright © 2016, Texas Instruments Incorporated

Figure 12. Slope Compensation

In peak current mode control, the optimal slope compensation is proportional to the slope of the inductor current during the power switch off-time. For boost converters, the inductor current slope while the MOSFET is off is $(V_O - V_{IN}) / L$. This relationship is combined with the requirements to set the peak current limit and is used to select R_{SNS} and R_{S2} in [Application and Implementation](#).

7.3.6 Soft Start

The soft-start feature allows the power converter output to gradually reach the initial steady-state output voltage, thereby reducing start-up stresses and current surges. At power on, after the VCC and input undervoltage lockout thresholds are satisfied, an internal 10-μA current source charges an external capacitor connected to the SS pin. The capacitor voltage ramps up slowly and limits the COMP pin voltage and the switch current.

7.3.7 MOSFET Gate Driver

The LM5022 provides an internal gate driver through the OUT pin that can source and sink a peak current of 1 A to control external, ground-referenced N-channel MOSFETs.

7.3.8 Thermal Shutdown

Internal thermal shutdown circuitry is provided to protect the LM5022 in the event that the maximum junction temperature is exceeded. When activated, typically at 165°C, the controller is forced into a low power standby state, disabling the output driver and the VCC regulator. After the temperature is reduced (typical hysteresis is 25°C) the VCC regulator is re-enabled and the LM5022 performs a soft start.

7.4 Device Functional Modes

7.4.1 Oscillator, Shutdown, and SYNC

A single external resistor, R_T , connected between the RT/SYNC and GND pins sets the LM5022 oscillator frequency. To set the switching frequency (f_{SW}), R_T can be calculated with [Equation 1](#).

$$R_T = \frac{(1 - 8 \times 10^{-8} \times f_{SW})}{f_{SW} \times 5.77 \times 10^{-11}}$$

where

- f_{SW} is in Hz
- R_T is in Ω

(1)

Device Functional Modes (continued)

The LM5022 can also be synchronized to an external clock. The external clock must have a higher frequency than the free-running oscillator frequency set by the R_T resistor. The clock signal must be capacitively coupled into the RT/SYNC pin with a 100-pF capacitor as shown in Figure 13. A peak voltage level greater than 3.8 V at the RT/SYNC pin is required for detection of the sync pulse. The sync pulse width must be set between 15 ns to 150 ns by the external components. The R_T resistor is always required, whether the oscillator is free-running or externally synchronized. The voltage at the RT/SYNC pin is internally regulated to 2 V, and the typical delay from a logic high at the RT/SYNC pin to the rise of the OUT pin voltage is 120 ns. R_T must be placed very close to the device and connected directly to the pins of the controller (RT/SYNC and GND).

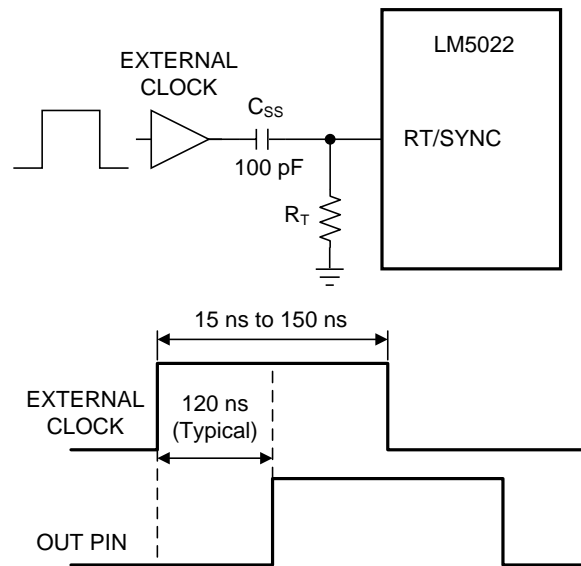

Copyright © 2016, Texas Instruments Incorporated

Figure 13. SYNC Operation

8 Application and Implementation

NOTE

Information in the following applications sections is not part of the TI component specification, and TI does not warrant its accuracy or completeness. TI's customers are responsible for determining suitability of components for their purposes. Customers should validate and test their design implementation to confirm system functionality.

8.1 Application Information

The most common circuit controlled by the LM5022 is a non-isolated boost regulator. The boost regulator steps up the input voltage and has a duty ratio D in Equation 2.

$$D = \frac{V_O - V_{IN} + V_D}{V_O + V_D}$$

where

- V_D is the forward voltage drop of the output diode (2)

The following is a design procedure for selecting all the components for the boost converter circuit shown in Figure 14. The application is *in-cabin* automotive, meaning that the operating ambient temperature ranges from -20°C to 85°C . This circuit operates in continuous conduction mode (CCM), where inductor current stays above 0 A at all times, and delivers an output voltage of $40\text{ V} \pm 2\%$ at a maximum output current of 0.5 A. Additionally, the regulator must be able to handle a load transient of up to 0.5 A while keeping V_O within $\pm 4\%$. The voltage input comes from the battery or alternator system of an automobile, where the standard range of 9 V to 16 V and transients of up to 32 V must not cause any malfunction.

8.2 Typical Application

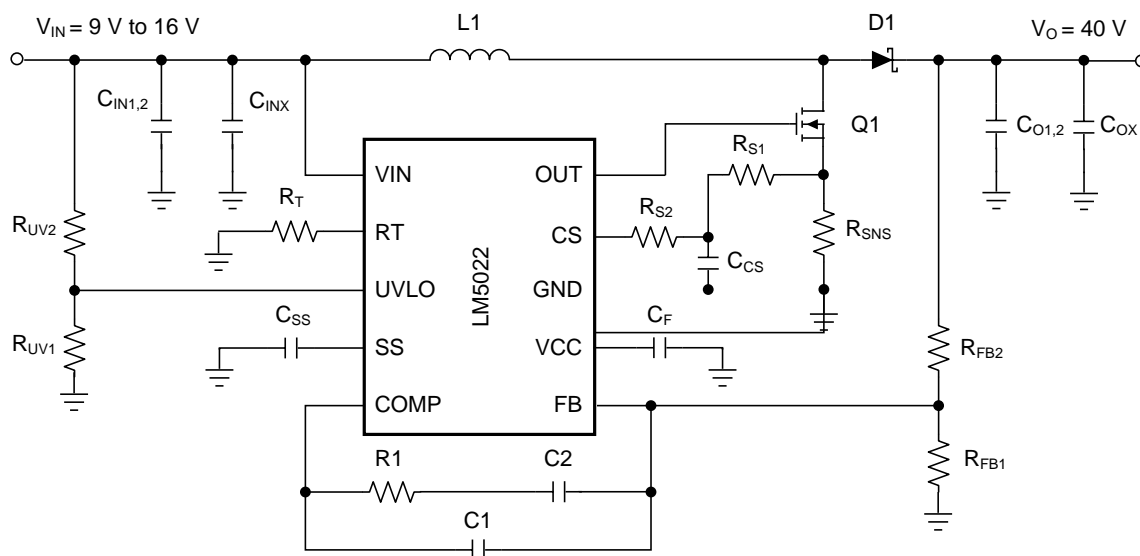

Copyright © 2016, Texas Instruments Incorporated

Figure 14. LM5022 Typical Application

Typical Application (continued)

8.2.1 Design Requirements

For typical low-side controller applications, use the parameters listed in [Table 1](#).

Table 1. Design Parameters

DESIGN PARAMETER	EXAMPLE VALUE
Input voltage range	9 V to 16 V
Output voltage	40 V
Maximum output current	500 mA
Switching frequency	500 kHz

8.2.2 Detailed Design Procedure

[Table 2](#) lists the bill of materials for this design example.

Table 2. BOM for Example Circuit

ID	PART NUMBER	TYPE	SIZE	PARAMETERS	QTY	VENDOR
U1	LM5022	Low-Side Controller	10-pin VSSOP	60 V	1	TI
Q1	Si4850EY	MOSFET	SO-8	60 V, 31 mΩ, 27 nC	1	Vishay
D1	CMSH2-60M	Schottky Diode	SMA	60 V, 2 A	1	Central Semi
L1	SLF12575T-M3R2	Inductor	12.5 × 12.5 × 7.5 mm	33 μH, 3.2 A, 40 mΩ	1	TDK
Cin1, Cin2	C4532X7R1H475M	Capacitor	1812	4.7 μF, 50 V, 3 mΩ	2	TDK
Co1, Co2	C5750X7R2A475M	Capacitor	2220	4.7 μF, 100 V, 3 mΩ	2	TDK
Cf	C2012X7R1E105K	Capacitor	0805	1 μF, 25 V	1	TDK
Cinx Cox	C2012X7R2A104M	Capacitor	0805	100 nF, 100 V	2	TDK
C1	VJ0805A561KXXAT	Capacitor	0805	560 pF 10%	1	Vishay
C2	VJ0805Y124KXXAT	Capacitor	0805	120 nF 10%	1	Vishay
Css	VJ0805Y103KXXAT	Capacitor	0805	10 nF 10%	1	Vishay
Ccs	VJ0805Y102KXXAT	Capacitor	0805	1 nF 10%	1	Vishay
R1	CRCW08053011F	Resistor	0805	3.01 kΩ 1%	1	Vishay
Rfb1	CRCW08056490F	Resistor	0805	649 Ω 1%	1	Vishay
Rfb2	CRCW08052002F	Resistor	0805	20 kΩ 1%	1	Vishay
Rs1	CRCW0805101J	Resistor	0805	100 Ω 5%	1	Vishay
Rs2	CRCW08053571F	Resistor	0805	3.57 kΩ 1%	1	Vishay
Rsns	ERJL14KF10C	Resistor	1210	100 mΩ, 1%, 0.5 W	1	Panasonic
Rt	CRCW08053322F	Resistor	0805	33.2 kΩ 1%	1	Vishay
Ruv1	CRCW08052611F	Resistor	0805	2.61 kΩ 1%	1	Vishay
Ruv2	CRCW08051002F	Resistor	0805	10 kΩ 1%	1	Vishay

8.2.2.1 Switching Frequency

The selection of switching frequency is based on the tradeoffs between size, cost, and efficiency. In general, a lower frequency means larger, more expensive inductors and capacitors is required. A higher switching frequency generally results in a smaller but less efficient solution, as the power MOSFET gate capacitances must be charged and discharged more often in a given amount of time. For this application, a frequency of 500 kHz was selected as a good compromise between the size of the inductor and efficiency. PCB area and component height are restricted in this application. Following [Equation 1](#), a 33.2-kΩ 1% resistor must be used to switch at 500 kHz.

8.2.2.2 MOSFET

Selection of the power MOSFET is governed by tradeoffs between cost, size, and efficiency. Breaking down the losses in the MOSFET is one way to determine relative efficiencies between different devices. For this example, the SO 8-pin package provides a balance of a small footprint with good efficiency (see Q1 in [Table 2](#)).

Losses in the MOSFET can be broken down into conduction loss, gate charging loss, and switching loss.

Conduction, or I^2R loss (P_C) is approximately [Equation 3](#).

$$P_C = D \times \left[\left(\frac{I_O}{1-D} \right) \times R_{\text{DS(on)}} \times 1.3 \right] \quad (3)$$

The factor 1.3 accounts for the increase in MOSFET on-resistance due to heating. Alternatively, the factor of 1.3 can be ignored and the maximum on-resistance of the MOSFET can be used.

Gate charging loss, P_G , results from the current required to charge and discharge the gate capacitance of the power MOSFET and is approximated with [Equation 4](#).

$$P_G = V_{CC} \times Q_G \times f_{\text{SW}} \quad (4)$$

Q_G is the total gate charge of the MOSFET. Gate charge loss differs from conduction and switching losses because the actual dissipation occurs in the LM5022 and not in the MOSFET itself. If no external bias is applied to the VCC pin, additional loss in the LM5022 IC occurs as the MOSFET driving current flows through the VCC regulator. This loss (P_{VCC}) is estimated with [Equation 5](#).

$$P_{VCC} = (V_{\text{IN}} - V_{CC}) \times Q_G \times f_{\text{SW}} \quad (5)$$

Switching loss (P_{SW}) occurs during the brief transition period as the MOSFET turns on and off. During the transition period both current and voltage are present in the channel of the MOSFET. The loss can be approximated with [Equation 6](#).

$$P_{\text{SW}} = 0.5 \times V_{\text{IN}} \times [I_O / (1-D)] \times (t_r + t_f) \times f_{\text{SW}}$$

where

- t_r is the rise time of the MOSFET
 - t_f is the fall time of the MOSFET
- (6)

For this example, the maximum drain-to-source voltage applied across the MOSFET is V_O plus the ringing due to parasitic inductance and capacitance. The maximum drive voltage at the gate of the high-side MOSFET is VCC, or 7 V typical. The MOSFET selected must be able to withstand 40 V plus any ringing from drain to source, and be able to handle at least 7 V plus ringing from gate to source. A minimum voltage rating of 50- $V_{\text{D-S}}$ and 10- $V_{\text{G-S}}$ MOSFET is used. Comparing the losses in a spreadsheet leads to a 60 $V_{\text{D-S}}$ rated MOSFET in SO-8 with an $R_{\text{DS(on)}}$ of 22 m Ω (the maximum value is 31 m Ω), a gate charge of 27 nC, and rise and falls times of 10 ns and 12 ns, respectively.

8.2.2.3 Output Diode

The boost regulator requires an output diode D1 (see [Figure 14](#)) to carrying the inductor current during the MOSFET off-time. The most efficient choice for D1 is a Schottky diode due to low forward drop and near-zero reverse recovery time. D1 must be rated to handle the maximum output voltage plus any switching node ringing when the MOSFET is on. In practice, all switching converters have some ringing at the switching node due to the diode parasitic capacitance and the lead inductance. D1 must also be rated to handle the average output current, I_O .

The overall converter efficiency becomes more dependent on the selection of D1 at low duty cycles, where the boost diode carries the load current for an increasing percentage of the time. This power dissipation can be calculating by checking the typical diode forward voltage, V_D , from the I-V curve on the diode's data sheet and then multiplying it by I_O . Diode data sheets also provides a typical junction-to-ambient thermal resistance, $R_{\theta\text{JA}}$, which can be used to estimate the operating die temperature of the Schottky. Multiplying the power dissipation ($P_D = I_O \times V_D$) by $R_{\theta\text{JA}}$ gives the temperature rise. The diode case size can then be selected to maintain the Schottky diode temperature below the operational maximum.

In this example a Schottky diode rated to 60 V and 1 A is suitable, as the maximum diode current is 0.5 A. A small case such as SOD-123 can be used if a small footprint is critical. Larger case sizes generally have lower $R_{\theta JA}$ and lower forward voltage drop, so for better efficiency the larger SMA case size is used.

8.2.2.4 Boost Inductor

The first criterion for selecting an inductor is the inductance itself. In fixed-frequency boost converters this value is based on the desired peak-to-peak ripple current, Δi_L , which flows in the inductor along with the average inductor current, I_L . For a boost converter in CCM I_L is greater than the average output current, I_O . The two currents are related by [Equation 7](#).

$$I_L = I_O / (1 - D) \quad (7)$$

As with switching frequency, the inductance used is a tradeoff between size and cost. Larger inductance means lower input ripple current, however because the inductor is connected to the output during the off-time only there is a limit to the reduction in output ripple voltage. Lower inductance results in smaller, less expensive magnetics. An inductance that gives a ripple current of 30% to 50% of I_L is a good starting point for a CCM boost converter. Minimum inductance must be calculated with [Equation 8](#) at the extremes of input voltage to find the operating condition with the highest requirement.

$$L_1 = \frac{V_{IN} \times D}{f_{SW} \times \Delta i_L} \quad (8)$$

By calculating in terms of amperes, volts, and megahertz, the inductance value comes out in micro henries.

To ensure that the boost regulator operates in CCM a second equation is required, and must also be evaluated with [Equation 9](#) at the corners of input voltage to find the minimum inductance required.

$$L_2 = \frac{D(1-D) \times V_{IN}}{I_O \times f_{SW}} \quad (9)$$

By calculating in terms of volts, amps, and megahertz, the inductance value comes out in μH .

For this design, Δi_L is set to 40% of the maximum I_L . Duty cycle is evaluated first at $V_{IN(MIN)}$ and at $V_{IN(MAX)}$. Second, the average inductor current is evaluated at the two input voltages. Third, the inductor ripple current is determined. Finally, the inductance can be calculated, and a standard inductor value selected that meets all the criteria.

1. Inductance for Minimum Input Voltage ([Equation 10](#), [Equation 11](#), and [Equation 12](#))

$$D_{VIN(MIN)} = (40 - 9 + 0.5) / (40 + 0.5) = 78\% \quad I_{L-VIN(MIN)} = 0.5 / (1 - 0.78) = 2.3 \text{ A} \quad \Delta i_L = 0.4 \times 2.3 \text{ A} = 0.92 \text{ A} \quad (10)$$

$$L_{1-VIN(MIN)} = \frac{9 \times 0.78}{0.5 \times 0.92} = 15.3 \mu\text{H} \quad (11)$$

$$L_{2-VIN(MIN)} = \frac{0.78 \times 0.22 \times 9}{0.5 \times 0.5} = 6.2 \mu\text{H} \quad (12)$$

2. Inductance for Maximum Input Voltage ([Equation 13](#), [Equation 14](#), and [Equation 15](#))

$$D_{VIN(MAX)} = (40 - 16 + 0.5) / (40 + 0.5) = 60\% \quad I_{L-VIN(MAX)} = 0.5 / (1 - 0.6) = 1.25 \text{ A} \quad \Delta i_L = 0.4 \times 1.25 \text{ A} = 0.5 \text{ A} \quad (13)$$

$$L_{1-VIN(MIN)} = \frac{16 \times 0.6}{0.5 \times 0.5} = 38.4 \mu\text{H} \quad (14)$$

$$L_{2-VIN(MIN)} = \frac{0.6 \times 0.4 \times 16}{0.5 \times 0.5} = 15.4 \mu\text{H} \quad (15)$$

Maximum average inductor current occurs at $V_{IN(MIN)}$, and the corresponding inductor ripple current is 0.92 A_{p.p.}. Selecting an inductance that exceeds the ripple current requirement at $V_{IN(MIN)}$ and the requirement to stay in CCM for $V_{IN(MAX)}$ provides a tradeoff that allows smaller magnetics at the cost of higher ripple current at maximum input voltage. For this example, a 33- μH inductor satisfies these requirements.

The second criterion for selecting an inductor is the peak current carrying capability. This is the level above which the inductor saturates. In saturation, the inductance can drop off severely, resulting in higher peak current that may overheat the inductor or push the converter into current limit. In a boost converter, peak current, I_{PK} , is equal to the maximum average inductor current plus one half of the ripple current. First, the current ripple must be determined under the conditions that give maximum average inductor current with [Equation 16](#).

$$\Delta i_L = \frac{V_{IN} \times D}{f_{SW} \times L} \quad (16)$$

Maximum average inductor current occurs at $V_{IN(MIN)}$. Using the selected inductance of 33 μH yields [Equation 17](#).

$$\Delta i_L = (9 \times 0.78) / (0.5 \times 33) = 425 \text{ mA}_{p-p} \quad (17)$$

The highest peak inductor current over all operating conditions is therefore [Equation 18](#).

$$I_{PK} = I_L + 0.5 \times \Delta i_L = 2.3 + 0.213 = 2.51 \text{ A} \quad (18)$$

Hence an inductor must be selected that has a peak current rating greater than 2.5 A and an average current rating greater than 2.3 A. One possibility is an off-the-shelf 33 $\mu\text{H} \pm 20\%$ inductor that can handle a peak current of 3.2 A and an average current of 3.4 A. Finally, the inductor current ripple is recalculated with [Equation 19](#) at the maximum input voltage.

$$\Delta i_{L-VIN(MAX)} = (16 \times 0.6) / (0.5 \times 33) = 0.58 \text{ A}_{p-p} \quad (19)$$

8.2.2.5 Output Capacitor

The output capacitor in a boost regulator supplies current to the load during the MOSFET on-time and also filters the AC portion of the load current during the off-time. This capacitor determines the steady-state output voltage ripple, ΔV_O , a critical parameter for all voltage regulators. Output capacitors are selected based on their capacitance, C_O , their equivalent series resistance (ESR) and their RMS or AC current rating.

The magnitude of ΔV_O is comprised of three parts, and in steady-state the ripple voltage during the on-time is equal to the ripple voltage during the off-time. For simplicity the analysis is performed for the MOSFET turning off (off-time) only. The first part of the ripple voltage is the surge created as the output diode D1 turns on. At this point, inductor and diode current are at peak value, and the ripple voltage increase can be calculated with [Equation 20](#).

$$\Delta V_{O1} = I_{PK} \times \text{ESR} \quad (20)$$

The second portion of the ripple voltage is the increase due to the charging of C_O through the output diode. This portion can be approximated with [Equation 21](#).

$$\Delta V_{O2} = (I_O / C_O) \times (D / f_{SW}) \quad (21)$$

The final portion of the ripple voltage is a decrease due to the flow of the diode and inductor current through the ESR of the output capacitor. This decrease can be calculated with [Equation 22](#).

$$\Delta V_{O3} = \Delta i_L \times \text{ESR} \quad (22)$$

The total change in output voltage is [Equation 23](#).

$$\Delta V_O = \Delta V_{O1} + \Delta V_{O2} - \Delta V_{O3} \quad (23)$$

The combination of two positive terms and one negative term may yield an output voltage ripple with a net rise or a net fall during the converter off-time. The ESR of the output capacitor(s) has a strong influence on the slope and direction of ΔV_O . Capacitors with high ESR such as tantalum and aluminum electrolytic create an output voltage ripple that is dominated by ΔV_{O1} and ΔV_{O3} , with a shape shown in [Figure 15](#). Ceramic capacitors, in contrast, have very low ESR and lower capacitance. The shape of the output ripple voltage is dominated by ΔV_{O2} , with a shape shown in [Figure 16](#).

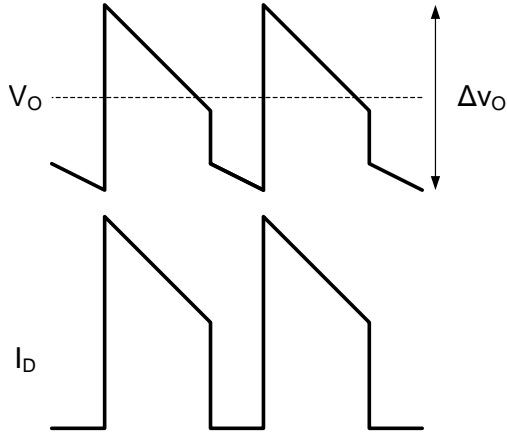
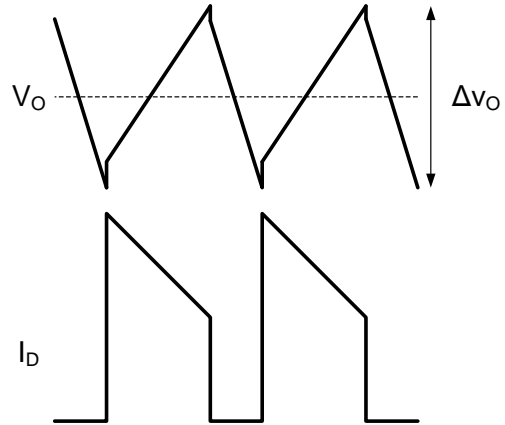
Figure 15. ΔV_O Using High-ESR Capacitors

Figure 16. ΔV_O Using Low-ESR Capacitors

For this example the small size and high temperature rating of ceramic capacitors make them a good choice. The output ripple voltage waveform of [Figure 16](#) is assumed, and the capacitance is selected first. The desired ΔV_O is $\pm 2\%$ of 40 V, or 0.8 V_{P-P}. Beginning with the calculation for ΔV_{O2} , the required minimum capacitance is in [Equation 24](#).

$$C_{O-MIN} = (I_O / \Delta V_O) \times (D_{MAX} / f_{SW}) \quad C_{O-MIN} = (0.5 / 0.8) \times (0.77 / 5 \times 10^5) = 0.96 \mu\text{F} \quad (24)$$

The next higher standard 20% capacitor value is 1 μF , however to provide margin for component tolerance and load transients two capacitors rated 4.7 μF each ($C_O = 9.4 \mu\text{F}$) is used. Ceramic capacitors rated 4.7 $\mu\text{F} \pm 20\%$ are available from many manufacturers. The minimum quality dielectric that is suitable for switching power supply output capacitors is X5R, while X7R (or better) is preferred. Pay careful attention to the DC voltage rating and case size, as ceramic capacitors can lose 60% or more of their rated capacitance at the maximum DC voltage. This is the reason that ceramic capacitors are often de-rated to 50% of their capacitance at their working voltage. The output capacitors for this example has a 100-V rating in a 2220 case size.

The typical ESR of the selected capacitors is 3 m Ω each, and in parallel is approximately 1.5 m Ω . The worst-case value for ΔV_{O1} occurs during the peak current at minimum input voltage in [Equation 25](#).

$$\Delta V_{O1} = 2.5 \times 0.0015 = 4 \text{ mV} \quad (25)$$

The worst-case capacitor charging ripple occurs at maximum duty cycle in [Equation 26](#).

$$\Delta V_{O2} = (0.5 / 9.4 \times 10^{-6}) \times (0.77 / 5 \times 10^5) = 82 \text{ mV} \quad (26)$$

Finally, the worst-case value for ΔV_{O3} occurs when inductor ripple current is highest, at maximum input voltage in [Equation 27](#).

$$\Delta V_{O3} = 0.58 \times 0.0015 = 1 \text{ mV (negligible)} \quad (27)$$

The output voltage ripple can be estimated by summing the three terms in [Equation 28](#).

$$\Delta V_O = 4 \text{ mV} + 82 \text{ mV} - 1 \text{ mV} = 85 \text{ mV} \quad (28)$$

The RMS current through the output capacitor(s) can be estimated using the following, worst-case equation in [Equation 29](#).

$$I_{O-RMS} = 1.13 \times I_L \times \sqrt{D \times (1-D)} \quad (29)$$

The highest RMS current occurs at minimum input voltage. For this example the maximum output capacitor RMS current is calculated with [Equation 30](#).

$$I_{O-RMS(MAX)} = 1.13 \times 2.3 \times (0.78 \times 0.22)^{0.5} = 1.08 \text{ A}_{RMS} \quad (30)$$

These 2220 case size devices are capable of sustaining RMS currents of over 3 A each, making them more than adequate for this application.

8.2.2.6 VCC Decoupling Capacitor

The VCC pin must be decoupled with a ceramic capacitor placed as close as possible to the VCC and GND pins of the LM5022. The decoupling capacitor must have a minimum X5R or X7R type dielectric to ensure that the capacitance remains stable over voltage and temperature, and be rated to a minimum of 470 nF. One good choice is a 1- μ F device with X7R dielectric and 1206 case size rated to 25 V.

8.2.2.7 Input Capacitor

The input capacitors to a boost regulator control the input voltage ripple (ΔV_{IN}) hold up the input voltage during load transients and prevent impedance mismatch (also called power supply interaction) between the LM5022 and the inductance of the input leads. Selection of input capacitors is based on their capacitance, ESR, and RMS current rating. The minimum value of ESR can be selected based on the maximum output current transient, I_{STEP} , using Equation 31.

$$ESR_{MIN} = \frac{(1 - D) \times \Delta V_{IN}}{2 \times I_{STEP}} \quad (31)$$

For this example, the maximum load step is equal to the load current or 0.5 A. The maximum permissible ΔV_{IN} during load transients is 4%_{P-P}. ΔV_{IN} and duty cycle are taken at minimum input voltage to give the worst-case value in Equation 32.

$$ESR_{MIN} = [(1 - 0.77) \times 0.36] / (2 \times 0.5) = 83 \text{ m}\Omega \quad (32)$$

The minimum input capacitance can be selected based on ΔV_{IN} , based on the drop in V_{IN} during a load transient, or based on prevention of power supply interaction. In general, the requirement for greatest capacitance comes from the power supply interaction. The inductance and resistance of the input source must be estimated, and if this information is not available, they can be assumed to be 1 μ H and 0.1 Ω , respectively. Minimum capacitance is then estimated with Equation 33.

$$C_{MIN} = \frac{2 \times L_S \times V_O \times I_O}{V_{IN}^2 \times R_S} \quad (33)$$

As with ESR, the worst-case, highest minimum capacitance calculation comes at the minimum input voltage. Using the default estimates for L_S and R_S , minimum capacitance is calculated with Equation 34.

$$C_{MIN} = \frac{2 \times 1\mu \times 40 \times 0.5}{9^2 \times 0.1} = 4.9 \mu\text{F} \quad (34)$$

The next highest standard 20% capacitor value is 6.8 μ F, but because the actual input source impedance and resistance are not known, two 4.7- μ F capacitors is used. In general, doubling the calculated value of input capacitance provides a good safety margin. The final calculation is for the RMS current. For boost converters operating in CCM this can be estimated with Equation 35.

$$I_{RMS} = 0.29 \times \Delta i_{L(MAX)} \quad (35)$$

From the inductor section, maximum inductor ripple current is 0.58 A, hence the input capacitor(s) must be rated to handle $0.29 \times 0.58 = 170 \text{ mA}_{RMS}$.

The input capacitors can be ceramic, tantalum, aluminum, or almost any type, however the low capacitance requirement makes ceramic capacitors particularly attractive. As with the output capacitors, the minimum quality dielectric used must X5R, with X7R or better preferred. The voltage rating for input capacitors requirement not be as conservative as the output capacitors, as the requirement for capacitance decreases as input voltage increases. For this example, the capacitor selected is 4.7 μ F \pm 20%, rated to 50 V in the 1812 case size. The RMS current rating of these capacitors is over 2 A each, more than enough for this application.

8.2.2.8 Current Sense Filter

Parasitic circuit capacitance, inductance and gate drive current create a spike in the current sense voltage at the point where Q1 turns on. To prevent this spike from terminating the on-time prematurely, every circuit must have a low-pass filter that consists of C_{CS} and R_{S1} , shown in Figure 14. The time constant of this filter must be long enough to reduce the parasitic spike without significantly affecting the shape of the actual current sense voltage. The recommended range for R_{S1} is between 10 Ω and 500 Ω , and the recommended range for C_{CS} is between 100 pF and 2.2 nF. For this example, the values of R_{S1} and C_{CS} is 100 Ω and 1 nF, respectively.

8.2.2.9 R_{SNS} , R_{S2} and Current Limit

The current sensing resistor R_{SNS} is used for steady-state regulation of the inductor current and to sense overcurrent conditions. The slope compensation resistor is used to ensure control loop stability, and both resistors affect the current limit threshold. The R_{SNS} value selected must be low enough to keep the power dissipation to a minimum, yet high enough to provide good signal-to-noise ratio for the current sensing circuitry. R_{SNS} , and R_{S2} must be set so that the current limit comparator, with a threshold of 0.5 V, trips before the sensed current exceeds the peak current rating of the inductor, without limiting the output power in steady state.

For this example the peak current, at $V_{IN(MIN)}$, is 2.5 A, while the inductor itself is rated to 3.2 A. The threshold for current limit, I_{LIM} , is set slightly between these two values to account for tolerance of the circuit components, at a level of 3 A. The required resistor calculation must take both the switch current through R_{SNS} and the compensation ramp current flowing through the internal 2 k Ω , R_{S1} and R_{S2} resistors into account. R_{SNS} must be selected first because it is a power resistor with more limited selection. [Equation 36](#) and [Equation 37](#) must be evaluated at $V_{IN(MIN)}$, when duty cycle is highest.

$$R_{SNS} = \frac{L \times f_{SW} \times V_{CL}}{(V_O - V_{IN}) \times 3 \times D + L \times f_{SW} \times I_{LIM}} \quad (36)$$

$$R_{SNS} = \frac{33 \times 0.5 \times 0.5}{(40 - 9) \times 3 \times 0.78 + 33 \times 0.5 \times 3}$$

where

- L is in μ H
 - f_{SW} in MHz
- (37)

The closest 5% value is 100 m Ω . Power dissipation in R_{SNS} can be estimated by calculating the average current. The worst-case average current through R_{SNS} occurs at minimum input voltage/maximum duty cycle and can be calculated with [Equation 38](#) and [Equation 39](#).

$$P_{CS} = \left[\left(\frac{I_O}{1 - D} \right)^2 \times R_{SNS} \right] \times D \quad (38)$$

$$P_{CS} = [(0.5 / 0.22)^2 \times 0.1] \times 0.78 = 0.4 \text{ W} \quad (39)$$

For this example, a 0.1 Ω \pm 1%, thick-film chip resistor in a 1210 case size rated to 0.5 W is used.

With R_{SNS} selected, R_{S2} can be determined using [Equation 40](#) and [Equation 41](#).

$$R_{S2} = \frac{V_{CL} - I_{LIM} \times R_{SNS}}{45\mu \times D} - 2000 - R_{S1} \quad (40)$$

$$R_{S2} = \frac{0.5 - 3 \times 0.1}{45\mu \times 0.78} - 2000 - 100 = 3598\Omega \quad (41)$$

The closest 1% tolerance value is 3.57 k Ω .

8.2.2.10 Control Loop Compensation

The LM5022 uses peak current-mode PWM control to correct changes in output voltage due to line and load transients. Peak current-mode provides inherent cycle-by-cycle current limiting, improved line transient response, and easier control loop compensation.

The control loop is comprised of two parts. The first is the power stage, which consists of the pulse width modulator, output filter, and the load. The second part is the error amplifier, which is an op-amp configured as an inverting amplifier. [Figure 17](#) shows the regulator control loop components.

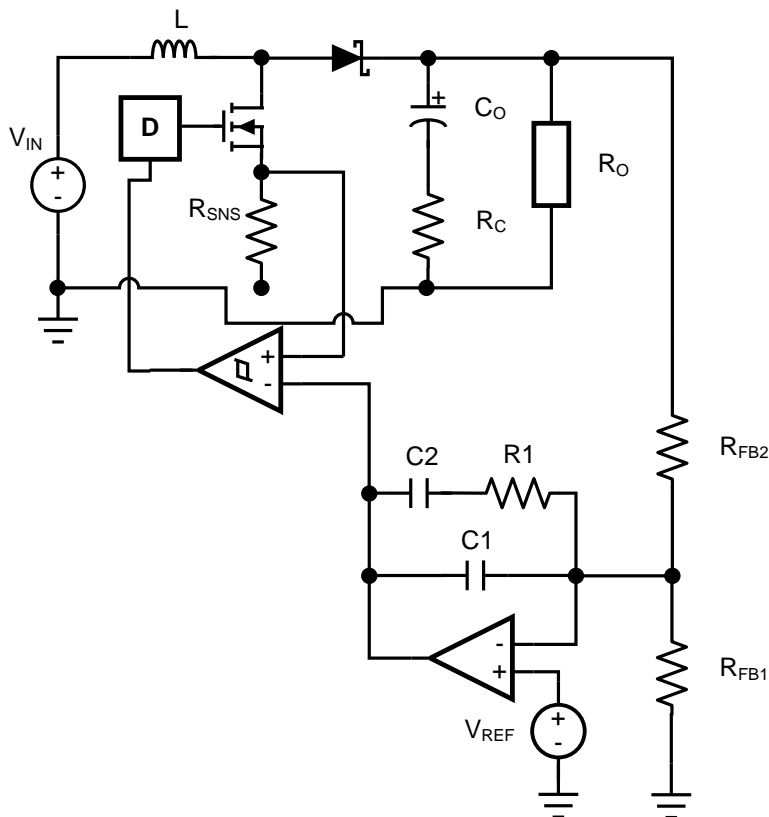
Figure 17. Power Stage and Error Amplifier

One popular method for selecting the compensation components is to create Bode plots of gain and phase for the power stage and error amplifier. Combined, they make the overall bandwidth and phase margin of the regulator easy to determine. Software tools such as Excel, MathCAD, and Matlab are useful for observing how changes in compensation or the power stage affect system gain and phase.

The power stage in a CCM peak current mode boost converter consists of the DC gain, A_{PS} , a single low-frequency pole, f_{LFP} , the ESR zero, f_{ZESR} , a right-half plane zero, f_{RHP} , and a double pole resulting from the sampling of the peak current. The power stage transfer function (also called the control-to-output transfer function) can be written with [Equation 42](#), [Equation 43](#), and [Equation 44](#).

$$G_{PS} = A_{PS} \times \frac{\left(1 + \frac{s}{\omega_{ZESR}}\right) \left(1 - \frac{s}{\omega_{RHP}}\right)}{\left(1 + \frac{s}{\omega_{LEP}}\right) \left(1 + \frac{s}{Q_n \times \omega_n} + \frac{s^2}{\omega_n^2}\right)}$$

where

- the DC gain is defined as:

(42)

$$A_{PS} = \frac{(1 - D) \times R_O}{2 \times R_{SNS}}$$

where

(43)

$$R_O = V_O / I_O$$

(44)

The system ESR zero is calculated with [Equation 45](#).

$$\omega_{\text{ZESR}} = \frac{1}{R_{\text{C}} \times C_{\text{O}}} \quad (45)$$

The low-frequency pole is calculated with [Equation 46](#).

$$\omega_{\text{LEP}} = \frac{1}{0.5 \times (R_{\text{O}} + \text{ESR}) \times C_{\text{O}}} \quad (46)$$

The right-half plane zero is calculated with [Equation 47](#).

$$\omega_{\text{RHP}} = \frac{R_{\text{O}} \times \left(\frac{V_{\text{IN}}}{V_{\text{O}}} \right)^2}{L} \quad (47)$$

The sampling double-pole quality factor is calculated with [Equation 48](#).

$$Q_{\text{n}} = \frac{1}{\pi \left[-D + 0.5 + (1 - D) \frac{S_{\text{e}}}{S_{\text{n}}} \right]} \quad (48)$$

The sampling double corner frequency is calculated with [Equation 49](#).

$$\omega_{\text{n}} = \pi \times f_{\text{SW}} \quad (49)$$

The natural inductor current slope is calculated with [Equation 50](#).

$$S_{\text{n}} = R_{\text{SNS}} \times V_{\text{IN}} / L \quad (50)$$

The external ramp slope is calculated with [Equation 51](#).

$$S_{\text{e}} = 45 \mu\text{A} \times (2000 + R_{\text{S1}} + R_{\text{S2}}) \times f_{\text{SW}} \quad (51)$$

In [Equation 43](#), DC gain is highest when input voltage and output current are at the maximum. In this the example those conditions are $V_{\text{IN}} = 16 \text{ V}$ and $I_{\text{O}} = 500 \text{ mA}$.

DC gain is 44 dB. The low-frequency pole $f_{\text{p}} = \omega_{\text{p}}/2\pi$ is at 423 Hz, the ESR zero $f_{\text{z}} = \omega_{\text{z}}/2\pi$ is at 5.6 MHz, and the right-half plane zero $f_{\text{RHP}} = \omega_{\text{RHP}}/2\pi$ is at 61 kHz. The sampling double-pole occurs at one-half of the switching frequency. Proper selection of slope compensation (through R_{S2}) is most evident the sampling double pole. A well-selected R_{S2} value eliminates peaking in the gain and reduces the rate of change of the phase lag. Gain and phase plots for the power stage are shown in [Figure 18](#) and [Figure 19](#).

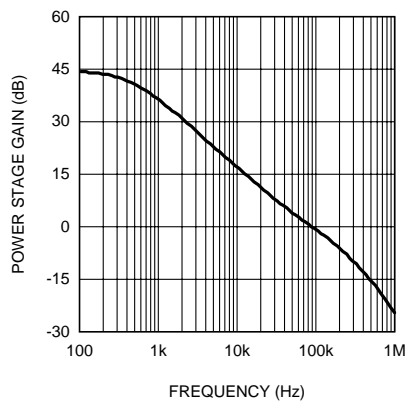

Figure 18. Power Stage Gain and Phase

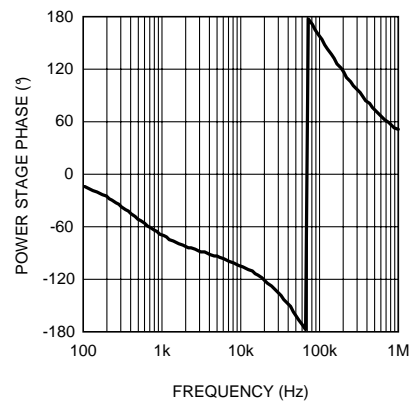

Figure 19. Power Stage Gain and Phase

The single pole causes a rolloff in the gain of -20 dB/decade at lower frequency. The combination of the RHP zero and sampling double pole maintain the slope out to beyond the switching frequency. The phase tends towards -90° at lower frequency but then increases to -180° and beyond from the RHP zero and the sampling double pole. The effect of the ESR zero is not seen because its frequency is several decades above the switching frequency. The combination of increasing gain and decreasing phase makes converters with RHP zeroes difficult to compensate. Setting the overall control loop bandwidth to $1/3$ to $1/10$ of the RHP zero frequency minimizes these negative effects, but requires a compromise in the control loop bandwidth. If this loop were left uncompensated, the bandwidth would be 89 kHz and the phase margin -54° . The converter would oscillate, and therefore is compensated using the error amplifier and a few passive components.

The transfer function of the compensation block (G_{EA}) can be derived by treating the error amplifier as an inverting op-amp with input impedance Z_I and feedback impedance Z_F . The majority of applications require a Type II, or two-pole one-zero amplifier, shown in [Figure 17](#). The LaPlace domain transfer function for this Type II network is given by [Equation 52](#).

$$G_{EA} = \frac{Z_F}{Z_I} = \frac{1}{R_{FB2}(C1 + C2)} \times \frac{s \times R1 \times C2 + 1}{s \left(\frac{s \times R1 \times C1 \times C2}{C1 + C2} + 1 \right)} \quad (52)$$

Many techniques exist for selecting the compensation component values. The following method is based upon setting the mid-band gain of the error amplifier transfer function first and then positioning the compensation zero and pole:

1. *Determine the desired control loop bandwidth:* The control loop bandwidth (f_{0dB}) is the point at which the total control loop gain ($H = G_{PS} \times G_{EA}$) is equal to 0 dB. For this example, a low bandwidth of 10 kHz, or approximately $1/6$ th of the RHP zero frequency, is chosen because of the wide variation in input voltage.
2. *Determine the gain of the power stage at f_{0dB} :* This value, A , can be read graphically from the gain plot of G_{PS} or calculated by replacing the 's' terms in G_{PS} with ' $2 \pi f_{0dB}$ '. For this example, the gain at 10 kHz is approximately 16 dB.
3. *Calculate the negative of A and convert it to a linear gain:* By setting the mid-band gain of the error amplifier to the negative of the power stage gain at f_{0dB} , the control loop gain equals 0 dB at that frequency. For this example, -16 dB = 0.15 V/V.
4. *Select the resistance of the top feedback divider resistor R_{FB2} :* This value is arbitrary, however selecting a resistance between 10 k Ω and 100 k Ω leads to practical values of $R1$, $C1$, and $C2$. For this example, $R_{FB2} = 20$ k Ω 1%.

5. Set [Equation 55](#):

$$R1 = A \times R_{FB2} \quad (53)$$

For this example: $R1 = 0.15 \times 20000 = 3$ k Ω

6. *Select a frequency for the compensation zero, f_{Z1} :* The suggested placement for this zero is at the low-frequency pole of the power stage, $f_{LFP} = \omega_{LFP} / 2\pi$. For this example, $f_{Z1} = f_{LFP} = 423$ Hz
7. Set [Equation 54](#).

$$C2 = \frac{1}{2\pi \times R1 \times f_{Z1}} \quad (54)$$

For this example, $C2 = 125$ nF

8. *Select a frequency for the compensation pole, f_{P1} :* The suggested placement for this pole is at one-fifth of the switching frequency. For this example, $f_{P1} = 100$ kHz
9. Set [Equation 55](#).

$$C1 = \frac{C2}{2\pi \times C2 \times R1 \times f_{P1} - 1} \quad (55)$$

For this example, $C1 = 530$ pF

10. Plug the closest 1% tolerance values for R_{FB2} and $R1$, then the closest 10% values for $C1$ and $C2$ into G_{EA} and model the error amp: The open-loop gain and bandwidth of the LM5022's internal error amplifier are 75 dB and 4 MHz, respectively. Their effect on G_{EA} can be modeled using Equation 56:

$$OPG = \frac{2\pi \times GBW}{s + \frac{2\pi \times GBW}{A_{DC}}} \tag{56}$$

A_{DC} is a linear gain, the linear equivalent of 75 dB is approximately 5600 V/V. $C1 = 560$ pF 10%, $C2 = 120$ nF 10%, $R1 = 3.01$ k Ω 1%

11. Plot or evaluate the actual error amplifier transfer function:

$$G_{EA-ACTUAL} = \frac{G_{EA} \times OPG}{1 + G_{EA} \times OPG} \tag{57}$$

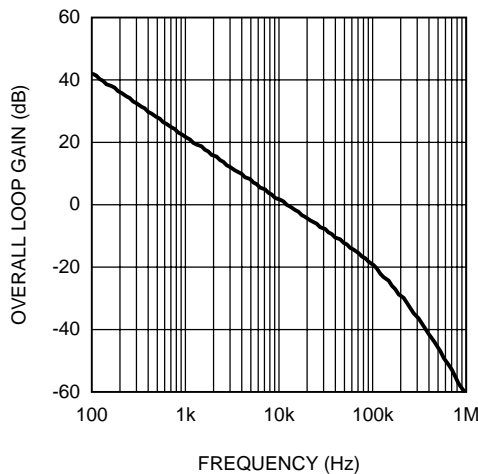

Figure 20. Overall Loop Gain and Phase

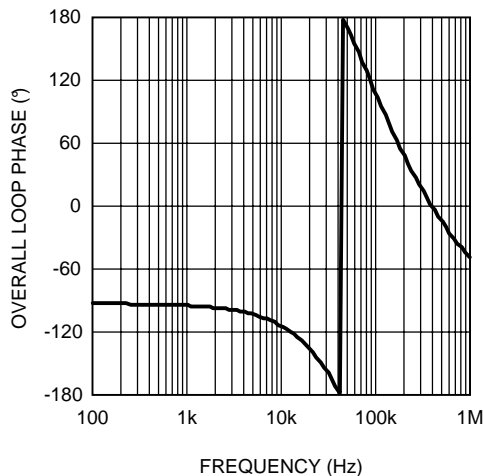

Figure 21. Overall Loop Gain and Phase

12. Plot or evaluate the complete control loop transfer function: The complete control loop transfer function is obtained by multiplying the power stage and error amplifier functions together. The bandwidth and phase margin can then be read graphically or evaluated numerically. The bandwidth of this example circuit at $V_{IN} = 16$ V is 10.5 kHz with a phase margin of 66°.

13. *Re-evaluate at the corners of input voltage and output current:* Boost converters exhibit significant change in their loop response when V_{IN} and I_O change. With the compensation fixed, the total control loop gain and phase must be checked to ensure a minimum phase margin of 45° over both line and load.

8.2.2.11 Efficiency Calculations

A reasonable estimation for the efficiency of a boost regulator controlled by the LM5022 can be obtained by adding together the loss in each current carrying element and using [Equation 58](#).

$$\eta = \frac{P_O}{P_O + P_{\text{total-loss}}} \quad (58)$$

The following shows an efficiency calculation to complement the circuit design. Output power for this circuit is $40 \text{ V} \times 0.5 \text{ A} = 20 \text{ W}$. Input voltage is assumed to be 13.8 V , and the calculations used assume that the converter runs in CCM. Duty cycle for $V_{IN} = 13.8 \text{ V}$ is 66%, and the average inductor current is 1.5 A .

8.2.2.11.1 Chip Operating Loss

This term accounts for the current drawn at the VIN pin. This current, I_{IN} , drives the logic circuitry and the power MOSFETs. The gate driving loss term from [MOSFET](#) is included in the chip operating loss. For the LM5022, I_{IN} is equal to the steady-state operating current, I_{CC} , plus the MOSFET driving current, I_{GC} . Power is lost as this current passes through the internal linear regulator of the LM5022 in [Equation 59](#).

$$I_{GC} = Q_G \times f_{SW} I_{GC} = 27 \text{ nC} \times 500 \text{ kHz} = 13.5 \text{ mA} \quad (59)$$

I_{CC} is typically 3.5 mA (taken from [Electrical Characteristics](#)). Chip operating loss is then calculated with [Equation 60](#).

$$P_Q = V_{IN} \times (I_Q + I_{GC}) P_Q = 13.8 \times (3.5 \text{ m} + 13.5 \text{ m}) = 235 \text{ mW} \quad (60)$$

8.2.2.11.2 MOSFET Switching Loss

$$P_{SW} = 0.5 \times V_{IN} \times I_L \times (t_R + t_F) \times f_{SW} P_{SW} = 0.5 \times 13.8 \times 1.5 \times (10 \text{ ns} + 12 \text{ ns}) \times 5 \times 10^5 = 114 \text{ mW} \quad (61)$$

8.2.2.11.3 MOSFET and R_{SNS} Conduction Loss

$$P_C = D \times (I_L^2 \times (R_{DS(on)} \times 1.3 + R_{SNS})) P_C = 0.66 \times (1.5^2 \times (0.029 + 0.1)) = 192 \text{ mW} \quad (62)$$

8.2.2.11.4 Output Diode Loss

The average output diode current is equal to I_O or 0.5 A . The estimated forward drop (V_D) is 0.5 V . The output diode loss is [Equation 63](#).

$$P_{D1} = I_O \times V_D P_{D1} = 0.5 \times 0.5 = 0.25 \text{ W} \quad (63)$$

8.2.2.11.5 Input Capacitor Loss

This term represents the loss as input ripple current passes through the ESR of the input capacitor bank. In this equation 'n' is the number of capacitors in parallel. The $4.7\text{-}\mu\text{F}$ input capacitors selected have a combined ESR of approximately $1.5 \text{ m}\Omega$, and Δi_L for a 13.8-V input is 0.55 A in [Equation 64](#) and [Equation 65](#).

$$P_{CIN} = \frac{I_{IN-RMS}^2 \times ESR}{n} \quad (64)$$

$$I_{IN-RMS} = 0.29 \times \Delta i_L = 0.29 \times 0.55 = 0.16 \text{ A} P_{CIN} = [0.16^2 \times 0.0015] / 2 = 0.02 \text{ mW (negligible)} \quad (65)$$

8.2.2.11.6 Output Capacitor Loss

This term is calculated using the same method as the input capacitor loss, substituting the output capacitor RMS current for $V_{IN} = 13.8 \text{ V}$. The combined ESR of the output capacitors is also approximately $1.5 \text{ m}\Omega$ in [Equation 66](#).

$$I_{O-RMS} = 1.13 \times 1.5 \times (0.66 \times 0.34)^{0.5} = 0.8 \text{ A} P_{CO} = [0.8 \times 0.0015] / 2 = 0.6 \text{ mW} \quad (66)$$

8.2.2.11.7 Boost Inductor Loss

The typical DCR of the selected inductor is 40 mΩ in [Equation 67](#).

$$P_{DCR} = I_L^2 \times DCR \quad P_{DCR} = 1.5^2 \times 0.04 = 90 \text{ mW} \quad (67)$$

Core loss in the inductor is estimated to be equal to the DCR loss, adding an additional 90 mW to the total inductor loss.

8.2.2.11.8 Total Loss

$$P_{LOSS} = \text{Sum of All Loss Terms} = 972 \text{ mW} \quad (68)$$

8.2.2.11.9 Efficiency

$$\eta = 20 / (20 + 0.972) = 95\% \quad (69)$$

8.2.3 Application Curves

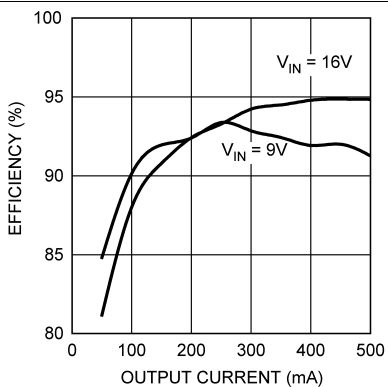
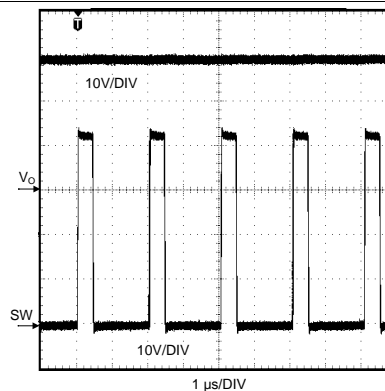
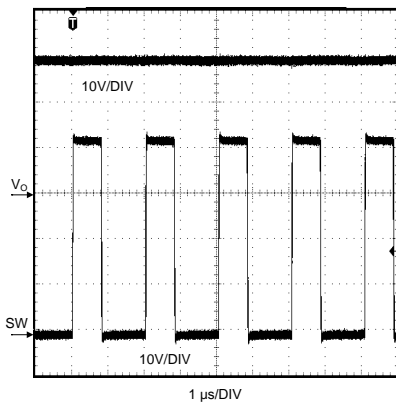

Figure 22. Efficiency



$V_{IN} = 9 \text{ V}, I_O = 0.5 \text{ A}$

Figure 23. Switch Node Voltage



$V_{IN} = 16 \text{ V}, I_O = 0.5 \text{ A}$

Figure 24. Switch Node Voltage

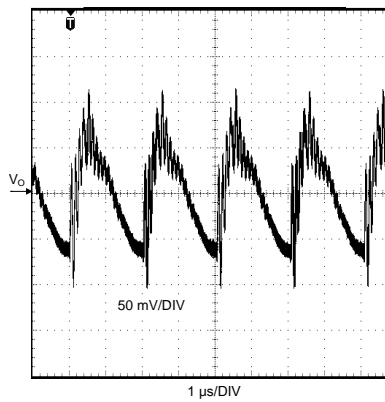

$V_{IN} = 9 \text{ V}, I_O = 0.5 \text{ A}$

Figure 25. Output Voltage Ripple AC Coupled

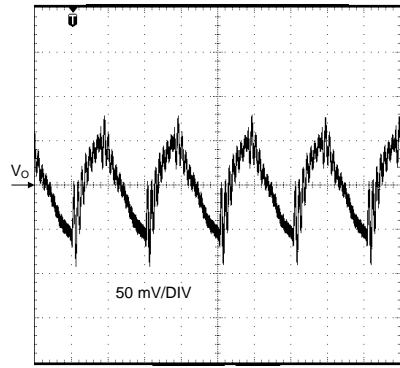

$V_{IN} = 16\text{ V}$, $I_O = 0.5\text{ A}$

Figure 26. Output Voltage Ripple AC Coupled

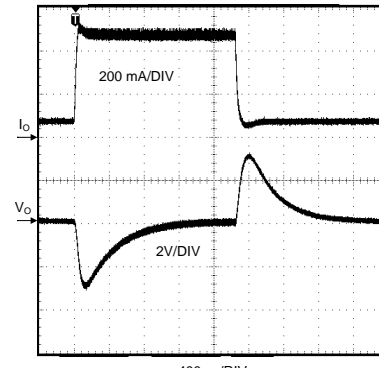

$V_{IN} = 9\text{ V}$, $I_O = 50\text{ mA to } 0.5\text{ A}$

Figure 27. Load Transient Response

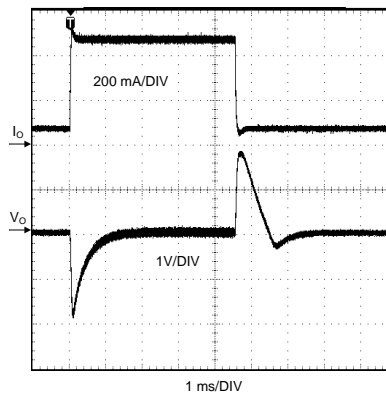

$V_{IN} = 16\text{ V}$, $I_O = 50\text{ mA to } 0.5\text{ A}$

Figure 28. Load Transient Response

9 Power Supply Recommendations

LM5022 is a power management device. The power supply for the device can be any DC voltage source within the specified input range.

10 Layout

10.1 Layout Guidelines

To produce an optimal power solution with the LM5022, good layout and design of the PCB are as critical as component selection. The following are the several guidelines to create a good layout of the PCB, as based on [Figure 14](#):

1. Using a low-ESR ceramic capacitor, place C_{INX} as close as possible to the VIN and GND pins of the LM5022.
2. Using a low-ESR ceramic capacitor, place C_{OX} close to the load as possible of the LM5022.
3. Using a low-ESR ceramic capacitor, place C_F close to the VCC and GND pins of the LM5022.
4. Minimize the loop area formed by the output capacitor connections (C_{O1} , C_{O2}) by D1 and R_{SNS} . Make sure the cathode of D1 and R_{SNS} are positioned next to each other, and place $C_{O1}(+)$ and $C_{O1}(-)$ close to D1 cathode and $R_{SNS}(-)$ respectively.
5. $R_{SNS}(+)$ must be connected to the CS pin with a separate trace made as short as possible. This trace must be routed away from the inductor and the switch node (where D1, Q1, and L1 connect).
6. Minimize the trace length to the FB pin by positioning R_{FB1} and R_{FB2} close to the LM5022.
7. Route the VOUT sense path away from noisy node and connect it as close as possible to the positive side of C_{OX} .

10.1.1 Filter Capacitors

The low-value ceramic filter capacitors are most effective when the inductance of the current loops that they filter is minimized. Place C_{INX} as close as possible to the VIN and GND pins of the LM5022. Place C_{OX} close to the load, and C_F next to the VCC and GND pins of the LM5022.

10.1.2 Sense Lines

The top of R_{SNS} must be connected to the CS pin with a separate trace made as short as possible. Route this trace away from the inductor and the switch node (where D1, Q1, and L1 connect). For the voltage loop, keep $R_{FB1/2}$ close to the LM5022 and run a trace from as close as possible to the positive side of C_{OX} to R_{FB2} . As with the CS line, the FB line must be routed away from the inductor and the switch node. These measures minimize the length of high impedance lines and reduce noise pickup.

10.1.3 Compact Layout

Parasitic inductance can be reduced by keeping the power path components close together. As described in [Layout Guidelines](#), keep the high slew-rate current loops as tight as possible. Short, thick traces or copper pours (shapes) are best.

The switch node must be just large enough to connect all the components together without excessive heating from the current it carries. The LM5022 (boost converter) operates in two distinct cycles whose high current paths are shown in [Figure 29](#).

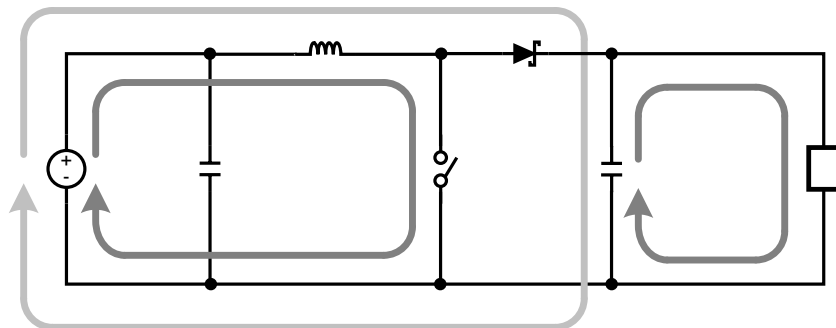

Figure 29. Boost Converter Current Loops

Layout Guidelines (continued)

The dark grey, inner loops represents the high current paths during the MOSFET on-time. The light grey, outer loop represents the high current path during the off-time.

10.1.4 Ground Plane and Shape Routing

The diagram of [Figure 29](#) is also useful for analyzing the flow of continuous current versus the flow of pulsating currents. The circuit paths with current flow during both the on-time and off-time are considered to be continuous current, while those that carry current during the on-time or off-time only are pulsating currents. Preference in routing must be given to the pulsating current paths, as these are the portions of the circuit most likely to emit EMI. The ground plane of a PCB is a conductor and return path, and it is susceptible to noise injection just as any other circuit path. The continuous current paths on the ground net can be routed on the system ground plane with less risk of injecting noise into other circuits. The path between the input source, input capacitor and the MOSFET and the path between the output capacitor and the load are examples of continuous current paths. In contrast, the path between the grounded side of the power switch and the negative output capacitor terminal carries a large pulsating current. This path must be routed with a short, thick shape, preferably on the component side of the PCB. Multiple vias in parallel must be used right at the negative pads of the input and output capacitors to connect the component side shapes to the ground plane. Vias must not be placed directly at the grounded side of the MOSFET (or R_{SNS}) as they tend to inject noise into the ground plane. A second pulsating current loop that is often ignored but must be kept small is the gate drive loop formed by the OUT and VCC pins, Q1, R_{SNS} , and capacitor C_F .

10.2 Layout Examples

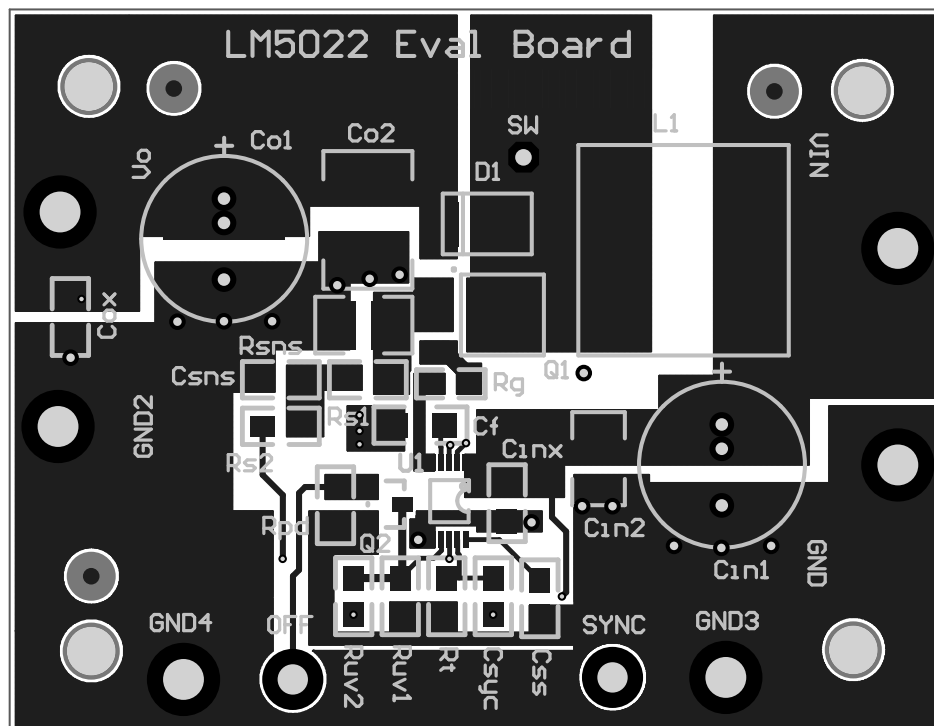

Figure 30. Top Layer and Top Overlay

Layout Examples (continued)

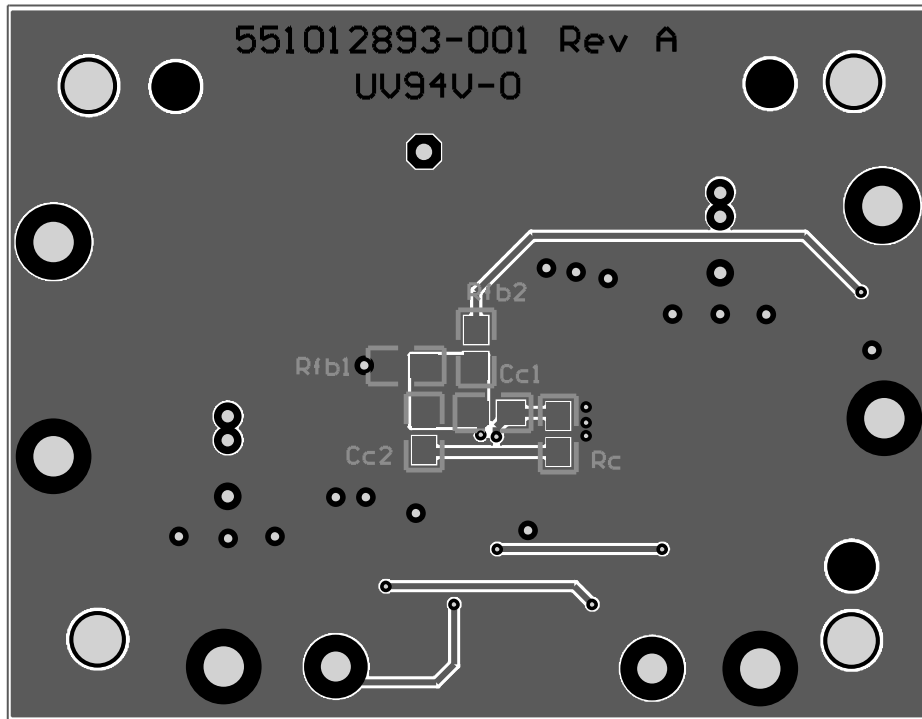

Figure 31. Bottom Layer

11 Device and Documentation Support

11.1 Device Support

11.1.1 Third-Party Products Disclaimer

TI'S PUBLICATION OF INFORMATION REGARDING THIRD-PARTY PRODUCTS OR SERVICES DOES NOT CONSTITUTE AN ENDORSEMENT REGARDING THE SUITABILITY OF SUCH PRODUCTS OR SERVICES OR A WARRANTY, REPRESENTATION OR ENDORSEMENT OF SUCH PRODUCTS OR SERVICES, EITHER ALONE OR IN COMBINATION WITH ANY TI PRODUCT OR SERVICE.

11.1.2 Design Support

WEBENCH® software uses an iterative design procedure and accesses comprehensive databases of components. For more details, go to www.ti.com/webench.

11.2 Documentation Support

11.2.1 Related Documentation

For related documentation see the following:

[AN-1557 LM5022 Evaluation Board](#) (SNVA203)

11.3 Receiving Notification of Documentation Updates

To receive notification of documentation updates, navigate to the device product folder on ti.com. In the upper right corner, click on *Alert me* to register and receive a weekly digest of any product information that has changed. For change details, review the revision history included in any revised document.

11.4 Community Resources

The following links connect to TI community resources. Linked contents are provided "AS IS" by the respective contributors. They do not constitute TI specifications and do not necessarily reflect TI's views; see TI's [Terms of Use](#).

TI E2E™ Online Community *TI's Engineer-to-Engineer (E2E) Community*. Created to foster collaboration among engineers. At e2e.ti.com, you can ask questions, share knowledge, explore ideas and help solve problems with fellow engineers.

Design Support *TI's Design Support* Quickly find helpful E2E forums along with design support tools and contact information for technical support.

11.5 Trademarks

E2E is a trademark of Texas Instruments.
WEBENCH is a registered trademark of Texas Instruments.
All other trademarks are the property of their respective owners.

11.6 Electrostatic Discharge Caution



These devices have limited built-in ESD protection. The leads should be shorted together or the device placed in conductive foam during storage or handling to prevent electrostatic damage to the MOS gates.

11.7 Glossary

[SLYZ022](#) — *TI Glossary*.

This glossary lists and explains terms, acronyms, and definitions.

12 Mechanical, Packaging, and Orderable Information

The following pages include mechanical, packaging, and orderable information. This information is the most current data available for the designated devices. This data is subject to change without notice and revision of this document. For browser-based versions of this data sheet, refer to the left-hand navigation.

PACKAGING INFORMATION

Orderable Device	Status (1)	Package Type	Package Drawing	Pins	Package Qty	Eco Plan (2)	Lead/Ball Finish (6)	MSL Peak Temp (3)	Op Temp (°C)	Device Marking (4/5)	Samples
LM5022MM	NRND	VSSOP	DGS	10	1000	TBD	Call TI	Call TI	-40 to 125	5022	
LM5022MM/NOPB	ACTIVE	VSSOP	DGS	10	1000	Green (RoHS & no Sb/Br)	CU SN	Level-1-260C-UNLIM	-40 to 125	5022	Samples
LM5022MME/NOPB	ACTIVE	VSSOP	DGS	10	250	Green (RoHS & no Sb/Br)	CU SN	Level-1-260C-UNLIM	-40 to 125	5022	Samples
LM5022MMX/NOPB	ACTIVE	VSSOP	DGS	10	3500	Green (RoHS & no Sb/Br)	CU SN	Level-1-260C-UNLIM	-40 to 125	5022	Samples

(1) The marketing status values are defined as follows:

ACTIVE: Product device recommended for new designs.

LIFEBUY: TI has announced that the device will be discontinued, and a lifetime-buy period is in effect.

NRND: Not recommended for new designs. Device is in production to support existing customers, but TI does not recommend using this part in a new design.

PREVIEW: Device has been announced but is not in production. Samples may or may not be available.

OBSELETE: TI has discontinued the production of the device.

(2) **RoHS:** TI defines "RoHS" to mean semiconductor products that are compliant with the current EU RoHS requirements for all 10 RoHS substances, including the requirement that RoHS substance do not exceed 0.1% by weight in homogeneous materials. Where designed to be soldered at high temperatures, "RoHS" products are suitable for use in specified lead-free processes. TI may reference these types of products as "Pb-Free".

RoHS Exempt: TI defines "RoHS Exempt" to mean products that contain lead but are compliant with EU RoHS pursuant to a specific EU RoHS exemption.

Green: TI defines "Green" to mean the content of Chlorine (Cl) and Bromine (Br) based flame retardants meet JS709B low halogen requirements of <=1000ppm threshold. Antimony trioxide based flame retardants must also meet the <=1000ppm threshold requirement.

(3) MSL, Peak Temp. - The Moisture Sensitivity Level rating according to the JEDEC industry standard classifications, and peak solder temperature.

(4) There may be additional marking, which relates to the logo, the lot trace code information, or the environmental category on the device.

(5) Multiple Device Markings will be inside parentheses. Only one Device Marking contained in parentheses and separated by a "-" will appear on a device. If a line is indented then it is a continuation of the previous line and the two combined represent the entire Device Marking for that device.

(6) Lead/Ball Finish - Orderable Devices may have multiple material finish options. Finish options are separated by a vertical ruled line. Lead/Ball Finish values may wrap to two lines if the finish value exceeds the maximum column width.

Important Information and Disclaimer:The information provided on this page represents TI's knowledge and belief as of the date that it is provided. TI bases its knowledge and belief on information provided by third parties, and makes no representation or warranty as to the accuracy of such information. Efforts are underway to better integrate information from third parties. TI has taken and continues to take reasonable steps to provide representative and accurate information but may not have conducted destructive testing or chemical analysis on incoming materials and chemicals. TI and TI suppliers consider certain information to be proprietary, and thus CAS numbers and other limited information may not be available for release.

In no event shall TI's liability arising out of such information exceed the total purchase price of the TI part(s) at issue in this document sold by TI to Customer on an annual basis.

OTHER QUALIFIED VERSIONS OF LM5022 :

- Automotive: [LM5022-Q1](#)

NOTE: Qualified Version Definitions:

- Automotive - Q100 devices qualified for high-reliability automotive applications targeting zero defects

TAPE AND REEL INFORMATION

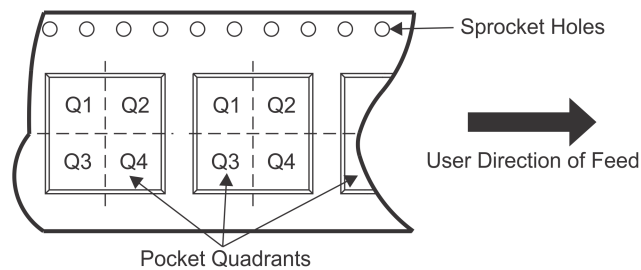
QUADRANT ASSIGNMENTS FOR PIN 1 ORIENTATION IN TAPE

*All dimensions are nominal

Device	Package Type	Package Drawing	Pins	SPQ	Reel Diameter (mm)	Reel Width W1 (mm)	A0 (mm)	B0 (mm)	K0 (mm)	P1 (mm)	W (mm)	Pin1 Quadrant
LM5022MM	VSSOP	DGS	10	1000	178.0	12.4	5.3	3.4	1.4	8.0	12.0	Q1
LM5022MM/NOPB	VSSOP	DGS	10	1000	178.0	12.4	5.3	3.4	1.4	8.0	12.0	Q1
LM5022MME/NOPB	VSSOP	DGS	10	250	178.0	12.4	5.3	3.4	1.4	8.0	12.0	Q1
LM5022MMX/NOPB	VSSOP	DGS	10	3500	330.0	12.4	5.3	3.4	1.4	8.0	12.0	Q1

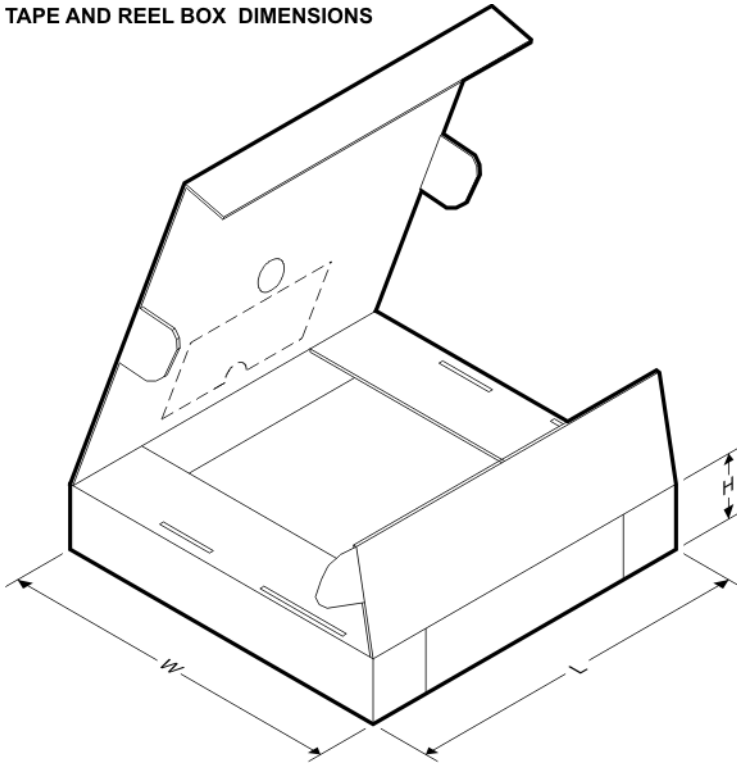
TAPE AND REEL BOX DIMENSIONS

*All dimensions are nominal

Device	Package Type	Package Drawing	Pins	SPQ	Length (mm)	Width (mm)	Height (mm)
LM5022MM	VSSOP	DGS	10	1000	210.0	185.0	35.0
LM5022MM/NOPB	VSSOP	DGS	10	1000	210.0	185.0	35.0
LM5022MME/NOPB	VSSOP	DGS	10	250	210.0	185.0	35.0
LM5022MMX/NOPB	VSSOP	DGS	10	3500	367.0	367.0	35.0

DGS0010A



PACKAGE OUTLINE

VSSOP - 1.1 mm max height

SMALL OUTLINE PACKAGE



4221984/A 05/2015

NOTES:

1. All linear dimensions are in millimeters. Any dimensions in parenthesis are for reference only. Dimensioning and tolerancing per ASME Y14.5M.
2. This drawing is subject to change without notice.
3. This dimension does not include mold flash, protrusions, or gate burrs. Mold flash, protrusions, or gate burrs shall not exceed 0.15 mm per side.
4. This dimension does not include interlead flash. Interlead flash shall not exceed 0.25 mm per side.
5. Reference JEDEC registration MO-187, variation BA.

EXAMPLE BOARD LAYOUT

DGS0010A

VSSOP - 1.1 mm max height

SMALL OUTLINE PACKAGE



LAND PATTERN EXAMPLE
SCALE:10X

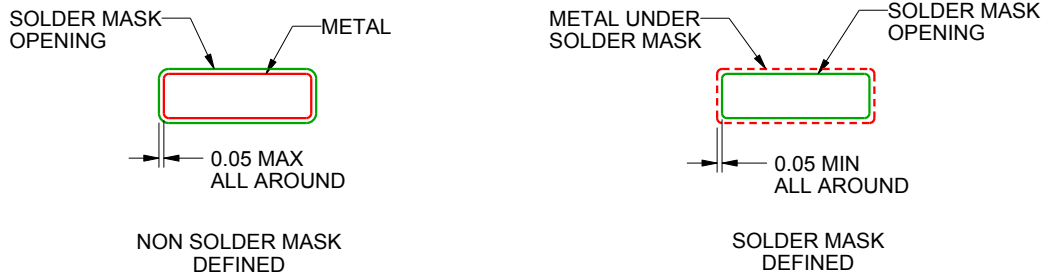

SOLDER MASK DETAILS
NOT TO SCALE

4221984/A 05/2015

NOTES: (continued)

- 6. Publication IPC-7351 may have alternate designs.
- 7. Solder mask tolerances between and around signal pads can vary based on board fabrication site.

EXAMPLE STENCIL DESIGN

DGS0010A

VSSOP - 1.1 mm max height

SMALL OUTLINE PACKAGE



SOLDER PASTE EXAMPLE
BASED ON 0.125 mm THICK STENCIL
SCALE:10X

4221984/A 05/2015

NOTES: (continued)

8. Laser cutting apertures with trapezoidal walls and rounded corners may offer better paste release. IPC-7525 may have alternate design recommendations.
9. Board assembly site may have different recommendations for stencil design.

IMPORTANT NOTICE AND DISCLAIMER

TI PROVIDES TECHNICAL AND RELIABILITY DATA (INCLUDING DATASHEETS), DESIGN RESOURCES (INCLUDING REFERENCE DESIGNS), APPLICATION OR OTHER DESIGN ADVICE, WEB TOOLS, SAFETY INFORMATION, AND OTHER RESOURCES "AS IS" AND WITH ALL FAULTS, AND DISCLAIMS ALL WARRANTIES, EXPRESS AND IMPLIED, INCLUDING WITHOUT LIMITATION ANY IMPLIED WARRANTIES OF MERCHANTABILITY, FITNESS FOR A PARTICULAR PURPOSE OR NON-INFRINGEMENT OF THIRD PARTY INTELLECTUAL PROPERTY RIGHTS.

These resources are intended for skilled developers designing with TI products. You are solely responsible for (1) selecting the appropriate TI products for your application, (2) designing, validating and testing your application, and (3) ensuring your application meets applicable standards, and any other safety, security, or other requirements. These resources are subject to change without notice. TI grants you permission to use these resources only for development of an application that uses the TI products described in the resource. Other reproduction and display of these resources is prohibited. No license is granted to any other TI intellectual property right or to any third party intellectual property right. TI disclaims responsibility for, and you will fully indemnify TI and its representatives against, any claims, damages, costs, losses, and liabilities arising out of your use of these resources.

TI's products are provided subject to TI's Terms of Sale (www.ti.com/legal/termsofsale.html) or other applicable terms available either on ti.com or provided in conjunction with such TI products. TI's provision of these resources does not expand or otherwise alter TI's applicable warranties or warranty disclaimers for TI products.

Mailing Address: Texas Instruments, Post Office Box 655303, Dallas, Texas 75265
Copyright © 2019, Texas Instruments Incorporated

Looking for pricing, stock, or lifecycle information?

Click below to explore more details on WIN SOURCE:

 [View LM5022MMX](#) on WIN SOURCE

 [Texas Instruments](#) Information

Optimize Your Supply Chain with WIN SOURCE Solutions

-  Global Sourcing Solution
-  Obsolete Management
-  Cost Control Management
-  Shortage Management
-  Alternative Solution
-  Excess Inventory Management