



THE DATASHEET OF LM5035AMHX/NOPB



LM5035A/LM5035A-1 PWM Controller with Integrated Half-Bridge and SyncFET Drivers

Check for Samples: [LM5035A](#)

FEATURES

- 105V / 2A Half-Bridge Gate Drivers
- Synchronous Rectifier Control Outputs with Programmable Delays
- High Voltage (105V) Start-up Regulator
- Voltage mode Control with Line Feed-Forward and Volt • Second Limiting
- Resistor Programmed, 2MHz Capable Oscillator
- Patent Pending Oscillator Synchronization
- Programmable Line Under-Voltage Lockout
- Line Over-Voltage Protection
- Internal Thermal Shutdown Protection
- Adjustable Soft-Start
- Versatile Dual Mode Over-Current Protection with Hiccup Delay Timer
- Cycle-by-Cycle Over-Current Protection
- Direct Opto-Coupler Interface
- 5V Reference Output

PACKAGES

- HTSSOP-20
- WQFN-24 (4mm x 5mm)
- HTSSOP-28 (LM5035A-1 only)

DESCRIPTION

The LM5035A Half-Bridge Controller/Gate Driver contains all of the features necessary to implement half-bridge topology power converters using voltage mode control with line voltage feed-forward. The LM5035A is a functional variant of the LM5035 half-bridge PWM controller. The VCC current limit threshold has been increased to 35 mA. The soft start and soft start currents have been increased from 50 μ A to 100 μ A. The BST UV threshold has been lowered to less than the VCC UV threshold. The ratio of the T1 and T2 delays on the SR1 and SR2 outputs has been increased from 2:1 to 3:1. The floating high-side gate driver is capable of operating with supply voltages up to 105V. Both the high-side and low-side gate drivers are capable of 2A peak. An internal high voltage startup regulator is included, along with programmable line undervoltage lockout (UVLO) and overvoltage protection (OVP). The oscillator is programmed with a single resistor to frequencies up to 2MHz. The oscillator can also be synchronized to an external clock. A current sense input and a programmable timer provide cycle-by-cycle current limit and adjustable hiccup mode overload protection. The differences between LM5035, LM5035A, LM5035B, and LM5035C are summarized in [Table 2](#).



Please be aware that an important notice concerning availability, standard warranty, and use in critical applications of Texas Instruments semiconductor products and disclaimers thereto appears at the end of this data sheet.

All trademarks are the property of their respective owners.

Simplified Application Diagram

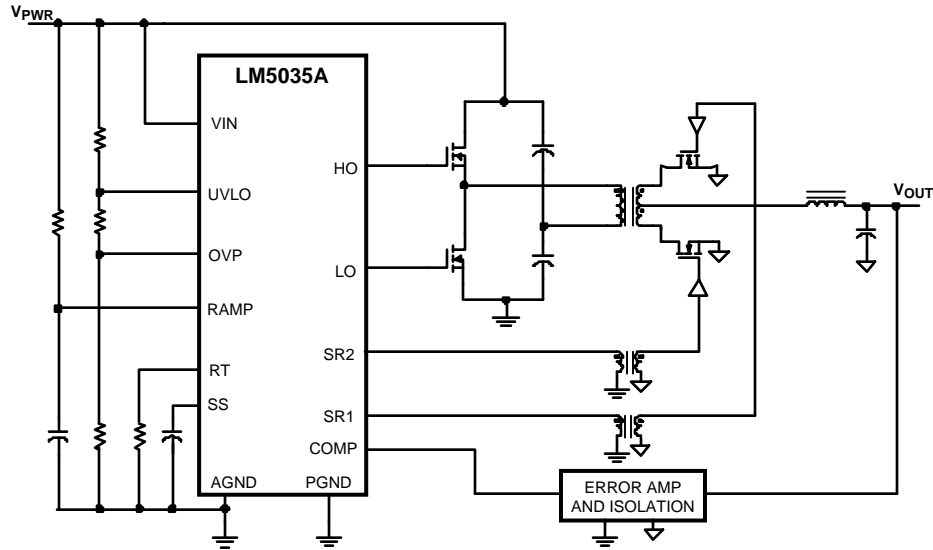

Connection Diagram

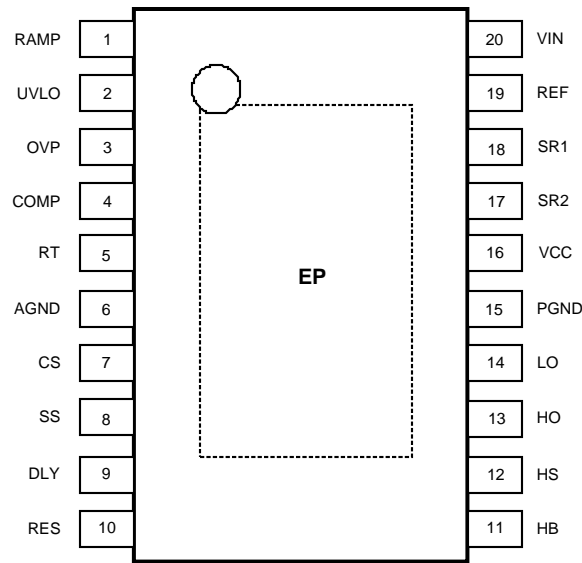

**Figure 1. LM5035A
20-Lead HTSSOP
(Top View)**

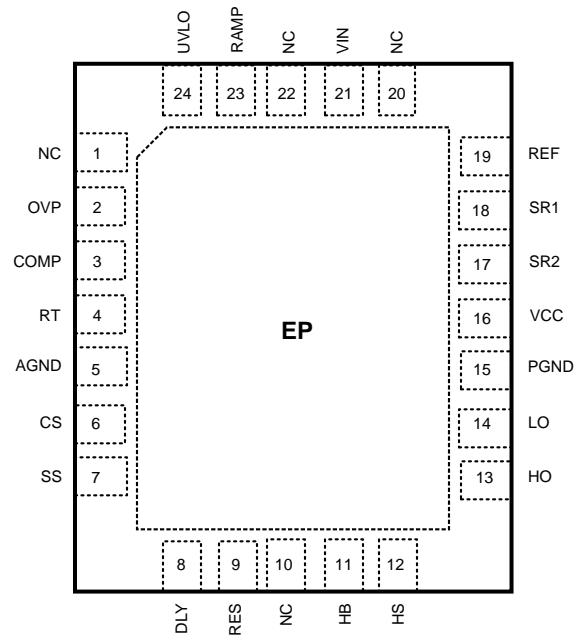

**Figure 2. LM5035A
20-Lead HTSSOP
(Top View)**

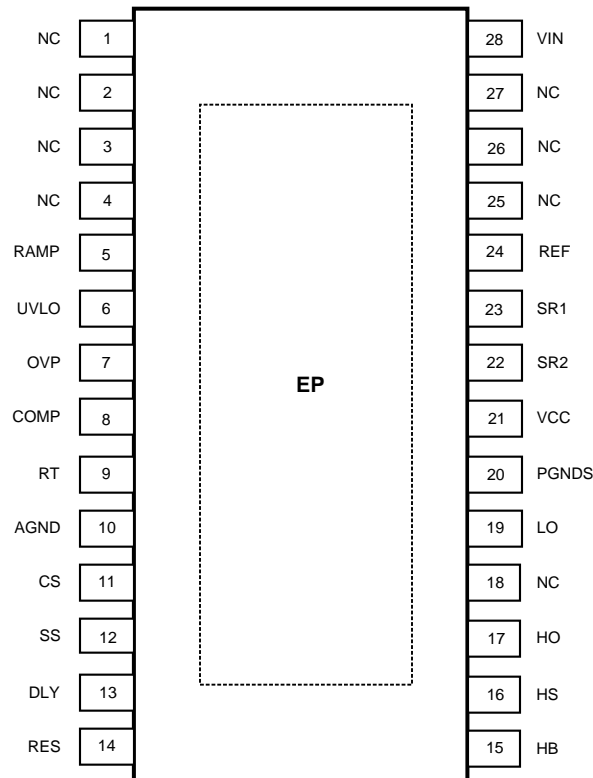

**Figure 3. LM5035A-1
28-Lead HTSSOP
(Top View)**

Pin Descriptions for LM5035A and LM5035A–1

| HTSSOP 20 PIN LM5035A | WQFN PIN LM5035A | HTSSOP 28 PIN LM5035A-1 | Name | Description | Application Information |
|--------------------------|---------------------|----------------------------|------|--|---|
| 1 | 23 | 5 | RAMP | Modulator ramp signal | An external RC circuit from VIN sets the ramp slope. This pin is discharged at the conclusion of every cycle by an internal FET. Discharge is initiated by either the internal clock or the Volt • Second clamp comparator. |
| 2 | 24 | 6 | UVLO | Line Under-Voltage Lockout | An external voltage divider from the power source sets the shutdown and standby comparator levels. When UVLO reaches the 0.4V threshold the VCC and REF regulators are enabled. When UVLO reaches the 1.25V threshold, the SS pin is released and the device enters the active mode. Hysteresis is set by an internal current sink that pulls 23 μ A from the external resistor divider. |
| 3 | 2 | 7 | OVP | Line Over-Voltage Protection | An external voltage divider from the power source sets the shutdown levels. The threshold is 1.25V. Hysteresis is set by an internal current source that sources 23 μ A into the external resistor divider. |
| 4 | 3 | 8 | COMP | Input to the Pulse Width Modulator | An external opto-coupler connected to the COMP pin sources current into an internal NPN current mirror. The PWM duty cycle is maximum with zero input current, while 1mA reduces the duty cycle to zero. The current mirror improves the frequency response by reducing the AC voltage across the opto-coupler detector. |
| 5 | 4 | 9 | RT | Oscillator Frequency Control and Sync Clock Input | Normally biased at 2V. An external resistor connected between RT and AGND sets the internal oscillator frequency. The internal oscillator can be synchronized to an external clock with a frequency higher than the free running frequency set by the RT resistor. |
| 6 | 5 | 10 | AGND | Analog Ground | Connect directly to Power Ground. |
| 7 | 6 | 11 | CS | Current Sense input for current limit | If CS exceeds 0.25V, the output pulse will be terminated, entering cycle-by-cycle current limit. An internal switch holds CS low for 50ns after HO or LO switches high to blank leading edge transients. |
| 8 | 7 | 12 | SS | Soft-start Input | An internal 110 μ A current source charges an external capacitor to set the soft-start rate. During a current limit restart sequence, the internal current source is reduced to 1.2 μ A to increase the delay before retry. |
| 9 | 8 | 13 | DLY | Timing programming pin for the LO and HO to SR1 and SR2 outputs. | An external resistor to ground sets the timing for the non-overlap time of HO to SR1 and LO to SR2. |
| 10 | 9 | 14 | RES | Restart Timer | If cycle-by-cycle current limit is exceeded during any cycle, a 22 μ A current is sourced to the RES pin capacitor. If the RES capacitor voltage reaches 2.5V, the soft-start capacitor will be fully discharged and then released with a pull-up current of 1.2 μ A. After the first output pulse at LO (when SS > COMP offset, typically 1V), the SS pin charging current will revert to 110 μ A. |

Pin Descriptions for LM5035A and LM5035A–1 (continued)

| HTSSOP 20 PIN LM5035A | WQFN PIN LM5035A | HTSSOP 28 PIN LM5035A-1 | Name | Description | Application Information |
|--------------------------|---------------------|----------------------------|------|--|---|
| 11 | 11 | 15 | HB | Boost voltage for the HO driver | An external diode is required from VCC to HB and an external capacitor is required from HS to HB to power the HO gate driver. |
| 12 | 12 | 16 | HS | Switch node | Connection common to the transformer and both power switches. Provides a return path for the HO gate driver. |
| 13 | 13 | 17 | HO | High side gate drive output. | Output of the high side PWM gate driver. Capable of sinking 2A peak current |
| 14 | 14 | 19 | LO | Low side gate ddrive output. | Output of the low side PWM gate driver. Capable of sinking 2A peak current. |
| 15 | 15 | 20 | PGND | Power Ground | Connect directly to Analog Ground. |
| 16 | 16 | 21 | VCC | Output of the high voltage start-up regulator. The VCC voltage is regulated to 7.6V. | If an auxiliary winding raises the voltage on this pin above the regulation setpoint, the Start-up Regulator will shutdown, thus reducing the internal power dissipation. |
| 17 | 17 | 22 | SR2 | Synchronous rectifier driver output. | Control output of the synchronous FET gate. Capable of 0.5A peak current. |
| 18 | 18 | 23 | SR1 | Synchronous rectifier driver output. | Control output of the synchronous FET gate. Capable of 0.5A peak current. |
| 19 | 19 | 24 | REF | Output of 5V Reference | Maximum output current is 20mA. Locally decoupled with a 0.1µF capacitor. |
| 20 | 21 | 28 | VIN | Input voltage source | Input to the Start-up Regulator. Operating input range is 13V to 100V with transient capability to 105V. For power sources outside of this range, the LM5035A can be biased directly at VCC by an external regulator. |
| | | 1 | NC | | |
| | | 2 | NC | | |
| | | 3 | NC | | |
| | | 4 | NC | | |
| | | 18 | NC | | |
| | | 25 | NC | | |
| | | 26 | NC | | |
| | | 27 | NC | | |
| EP | EP | | EP | Exposed Pad, underside of package | No electrical contact. Connect to system ground plane for reduced thermal resistance. |
| | 1 | | NC | No connection | No electrical contact. |
| | 10 | | NC | No connection | No electrical contact. |
| | 20 | | NC | No connection | No electrical contact. |
| | 22 | | NC | No connection | No electrical contact. |



These devices have limited built-in ESD protection. The leads should be shorted together or the device placed in conductive foam during storage or handling to prevent electrostatic damage to the MOS gates.

Absolute Maximum Ratings⁽¹⁾⁽²⁾

| | | |
|---------------------------|------------------|-----|
| VIN to GND | -0.3V to 105V | |
| HS to GND | -1V to 105V | |
| HB to GND | -0.3V to 118V | |
| HB to HS | -0.3V to 18V | |
| VCC to GND | -0.3V to 16V | |
| CS, RT, DLY to GND | -0.3V to 5.5V | |
| COMP Input Current | 10mA | |
| All other inputs to GND | -0.3V to 7V | |
| ESD Rating ⁽³⁾ | Human Body Model | 2kV |
| Storage Temperature Range | -65°C to 150°C | |
| Junction Temperature | 150°C | |

- (1) Absolute Maximum Ratings are limits beyond which damage to the device may occur. Operating Ratings are conditions under which operation of the device is intended to be functional. For ensured specifications and test conditions, see the Electrical Characteristics.
- (2) If Military/Aerospace specified devices are required, please contact the TI Sales Office/ Distributors for availability and specifications.
- (3) The human body model is a 100 pF capacitor discharged through a 1.5 kΩ resistor into each pin. 2kV for all pins except HB, HO and HS which are rated at 1.5kV.

Operating Ratings⁽¹⁾

| | |
|---------------------------------|-----------------|
| VIN Voltage | 13V to 105V |
| External Voltage Applied to VCC | 8V to 15V |
| Operating Junction Temperature | -40°C to +125°C |

- (1) Absolute Maximum Ratings are limits beyond which damage to the device may occur. Operating Ratings are conditions under which operation of the device is intended to be functional. For ensured specifications and test conditions, see the Electrical Characteristics.

Electrical Characteristics

Specifications with standard typeface are for $T_J = 25^\circ\text{C}$, and those with **boldface** type apply over full **Operating Junction Temperature range**. $V_{VIN} = 48\text{V}$, $V_{VCC} = 10\text{V}$ externally applied, $R_{RT} = 15.0\text{ k}\Omega$, $R_{DLY} = 27.4\text{ k}\Omega$, $V_{UVLO} = 3\text{V}$, $V_{OVP} = 0\text{V}$ unless otherwise stated. See ⁽¹⁾ and ⁽²⁾.

| Symbol | Parameter | Conditions | Min | Typ | Max | Units |
|---|--|---|--------------|------|--------------|---------------|
| Startup Regulator (VCC pin) | | | | | | |
| V_{VCC} | VCC voltage | $I_{VCC} = 10\text{mA}$ | 7.3 | 7.6 | 7.9 | V |
| $I_{VCC(LIM)}$ | VCC current limit | $V_{VCC} = 7\text{V}$ | 25 | 35 | | mA |
| V_{VCCUV} | VCC Under-voltage threshold (VCC increasing) | $V_{IN} = V_{CC}$, ΔV_{VCC} from the regulation setpoint | 0.2 | 0.1 | | V |
| | VCC decreasing | $V_{CC} - \text{PGND}$ | 5.5 | 6.2 | 6.9 | V |
| I_{VIN} | Startup regulator current | $V_{IN} = 90\text{V}$, $UVLO = 0\text{V}$ | | 30 | 70 | μA |
| | Supply current into VCC from external source | Outputs & COMP open, $V_{VCC} = 10\text{V}$, Outputs Switching | | 4 | 6 | mA |
| Voltage Reference Regulator (REF pin) | | | | | | |
| V_{REF} | REF Voltage | $I_{REF} = 0\text{mA}$ | 4.85 | 5 | 5.15 | V |
| | REF Voltage Regulation | $I_{REF} = 0$ to 10mA | | 25 | 50 | mV |
| | REF Current Limit | REF = 4.5V | 15 | 20 | | mA |
| Under-Voltage Lock Out and shutdown (UVLO pin) | | | | | | |
| V_{UVLO} | Under-voltage threshold | | 1.212 | 1.25 | 1.288 | V |
| I_{UVLO} | Hysteresis current | UVLO pin sinking | 19 | 23 | 27 | μA |
| | Under-voltage Shutdown Threshold | UVLO voltage falling | | 0.3 | | V |
| | Under-voltage Standby Enable Threshold | UVLO voltage rising | | 0.4 | | V |

- (1) All limits are ensured. All electrical characteristics having room temperature limits are tested during production with $T_A = 25^\circ\text{C}$. All hot and cold limits are ensured by correlating the electrical characteristics to process and temperature variations and applying statistical process control.
- (2) Typical specifications represent the most likely parametric norm at 25°C operation

Electrical Characteristics (continued)

Specifications with standard typeface are for $T_J = 25^\circ\text{C}$, and those with **boldface** type apply over full **Operating Junction Temperature range**. $V_{VIN} = 48\text{V}$, $V_{VCC} = 10\text{V}$ externally applied, $R_{RT} = 15.0\text{ k}\Omega$, $R_{DLY} = 27.4\text{ k}\Omega$, $V_{UVLO} = 3\text{V}$, $V_{OVP} = 0\text{V}$ unless otherwise stated. See ⁽¹⁾ and ⁽²⁾.

| Symbol | Parameter | Conditions | Min | Typ | Max | Units |
|---|--|---|--------------|------|--------------|---------------|
| Over-Voltage Protection (OVP pin) | | | | | | |
| V_{OVP} | Over-Voltage threshold | | 1.212 | 1.25 | 1.288 | V |
| I_{OVP} | Hysteresis current | OVP pin sourcing | 19 | 23 | 27 | μA |
| Current Sense Input (CS Pin) | | | | | | |
| V_{CS} | Current Limit Threshold | | 0.228 | 0.25 | 0.272 | V |
| | CS delay to output | CS from zero to 1V. Time for HO and LO to fall to 90% of VCC. Output load = 0 pF. | | 80 | | ns |
| | Leading edge blanking time at CS | | | 50 | | ns |
| | CS sink impedance (clocked) | Internal FET sink impedance | | 32 | 60 | Ω |
| Current Limit Restart (RES Pin) | | | | | | |
| V_{RES} | RES Threshold | | 2.4 | 2.5 | 2.6 | V |
| | Charge source current | $V_{RES} = 1.5\text{V}$ | 16 | 22 | 28 | μA |
| | Discharge sink current | $V_{RES} = 1\text{V}$ | 8 | 12 | 16 | μA |
| Soft-Start (SS Pin) | | | | | | |
| I_{SS} | Charging current in normal operation | $V_{SS} = 0$ | 80 | 110 | 140 | μA |
| | Charging current during a hiccup mode restart | $V_{SS} = 0$ | 0.6 | 1.2 | 1.8 | μA |
| | Soft-stop Current Sink | $V_{SS} = 2.5\text{V}$ | 80 | 110 | 140 | μA |
| Oscillator (RT Pin) | | | | | | |
| F_{SW1} | Frequency 1 (at HO, half oscillator frequency) | $R_{RT} = 15\text{ k}\Omega$, $T_J = 25^\circ\text{C}$ | 185 | 200 | 215 | kHz |
| | | $R_{RT} = 15\text{ k}\Omega$, $T_J = -40^\circ\text{C}$ to 125°C | 180 | | 220 | |
| F_{SW2} | Frequency 2 (at HO, half oscillator frequency) | $R_{RT} = 5.49\text{ k}\Omega$ | 430 | 500 | 570 | kHz |
| | DC level | | | 2 | | V |
| | Input Sync threshold | | 2.5 | 3 | 3.4 | V |
| PWM Controller (Comp Pin) | | | | | | |
| | Delay to output | | | 80 | | ns |
| V_{PWM-OS} | SS to RAMP offset | | 0.7 | 1 | 1.2 | V |
| | Minimum duty cycle | $SS = 0\text{V}$ | | | 0 | % |
| | Small signal impedance | $I_{COMP} = 600\mu\text{A}$, COMP current to PWM voltage | | 5000 | | Ω |
| Main Output Drivers (HO and LO Pins) | | | | | | |
| | Output high voltage | $I_{OUT} = 50\text{mA}$, $V_{HB} - V_{HO}$, $V_{VCC} - V_{LO}$ | 0.5 | 0.25 | | V |
| | Output low voltage | $I_{OUT} = 100\text{ mA}$ | | 0.2 | 0.5 | V |
| | Rise time | $C_{LOAD} = 1\text{ nF}$ | | 15 | | ns |
| | Fall time | $C_{LOAD} = 1\text{ nF}$ | | 13 | | ns |
| | Deadtime, HO to LO, LO to HO | $V_{DLY} = V_{REF}$, $I_{COMP} = 0\text{mA}$ | 45 | 70 | 100 | ns |
| | Peak source current | $V_{HO,LO} = 0\text{V}$, $V_{VCC} = 10\text{V}$ | | 1.25 | | A |
| | Peak sink current | $V_{HO,LO} = 10\text{V}$, $V_{VCC} = 10\text{V}$ | | 2 | | A |
| | HB Threshold | V_{CC} rising | | 3.8 | | V |
| Voltage Feed-Forward (RAMP Pin) | | | | | | |
| | RAMP comparator threshold | COMP current = 0 | 2.4 | 2.5 | 2.6 | V |
| Synchronous Rectifier Drivers (SR1, SR2) | | | | | | |
| | Output high voltage | $I_{OUT} = 10\text{mA}$, $V_{VCC} - V_{SR1}$, $V_{VCC} - V_{SR2}$ | 0.25 | 0.1 | | V |
| | Output low voltage | $I_{OUT} = 20\text{ mA}$ (sink) | | 0.08 | 0.2 | V |
| | Rise time | $C_{LOAD} = 1\text{ nF}$ | | 40 | | ns |

Electrical Characteristics (continued)

Specifications with standard typeface are for $T_J = 25^\circ\text{C}$, and those with **boldface** type apply over full **Operating Junction Temperature range**. $V_{VIN} = 48\text{V}$, $V_{VCC} = 10\text{V}$ externally applied, $R_{RT} = 15.0\text{ k}\Omega$, $R_{DLY} = 27.4\text{ k}\Omega$, $V_{UVLO} = 3\text{V}$, $V_{OVP} = 0\text{V}$ unless otherwise stated. See ⁽¹⁾ and ⁽²⁾.

| Symbol | Parameter | Conditions | Min | Typ | Max | Units |
|---------------------------|---|---|-----------|-----|------------|--------------------|
| | Fall time | $C_{LOAD} = 1\text{ nF}$ | | 20 | | ns |
| | Peak source current | $V_{SR} = 0$, $V_{VCC} = 10\text{V}$ | | 0.5 | | A |
| | Peak sink current | $V_{SR} = V_{VCC}$, $V_{VCC} = 10\text{V}$ | | 0.5 | | A |
| T1 | Deadtime, SR1 falling to HO rising, SR2 falling to LO rising | $R_{DLY} = 10\text{k}$ | | 33 | | ns |
| | | $R_{DLY} = 27.4\text{k}$ | 68 | 86 | 120 | ns |
| | | $R_{DLY} = 100\text{k}$ | | 300 | | ns |
| T2 | Deadtime, HO falling to SR1 rising, LO falling to SR2 rising | $R_{DLY} = 10\text{k}$ | | 18 | | ns |
| | | $R_{DLY} = 27.4\text{k}$ | 20 | 29 | 42 | ns |
| | | $R_{DLY} = 100\text{k}$ | | 80 | | ns |
| Thermal Shutdown | | | | | | |
| T_{SD} | Shutdown temperature | | | 165 | | $^\circ\text{C}$ |
| | Hysteresis | | | 20 | | $^\circ\text{C}$ |
| Thermal Resistance | | | | | | |
| θ_{JA} | Junction to ambient, 0 LFPM Air Flow | HTSSOP-20 package | | 40 | | $^\circ\text{C/W}$ |
| θ_{JC} | Junction to Case (EP) Thermal resistance | HTSSOP-20 package | | 4 | | $^\circ\text{C/W}$ |
| θ_{JA} | Junction to ambient, 0 LFM Air Flow | WQFN-24 (4 mm x 5 mm) | | 40 | | $^\circ\text{C/W}$ |
| θ_{JC} | Junction to Case Thermal resistance | WQFN-24 (4 mm x 5 mm) | | 6 | | $^\circ\text{C/W}$ |

Typical Performance Characteristics

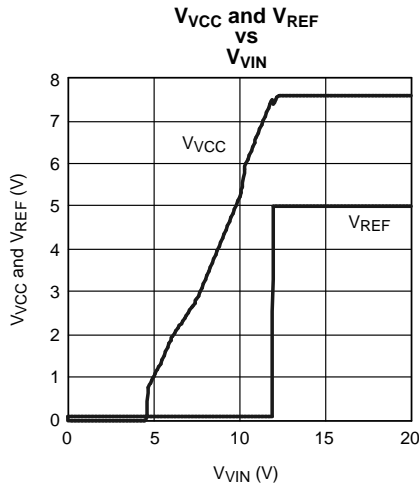

Figure 4.

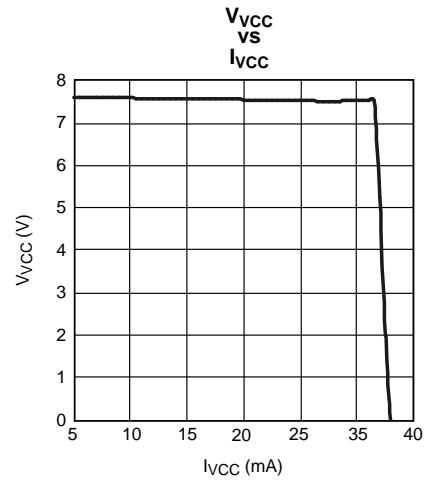

Figure 5.

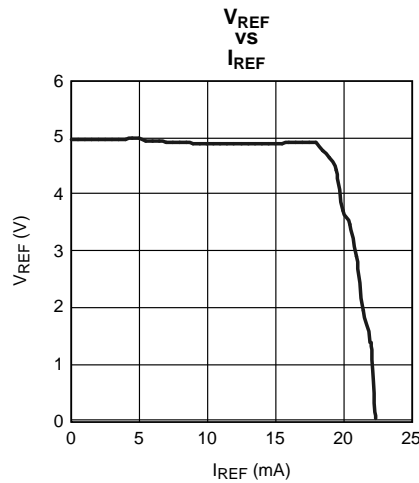

Figure 6.

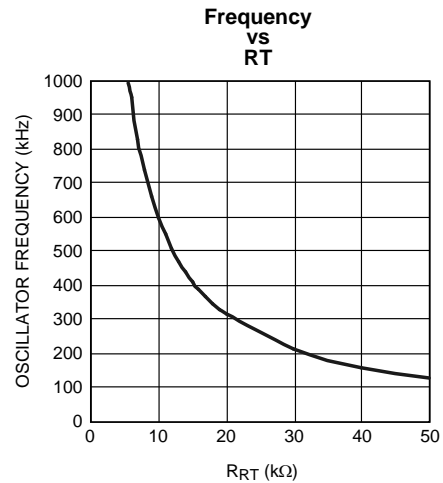

Figure 7.

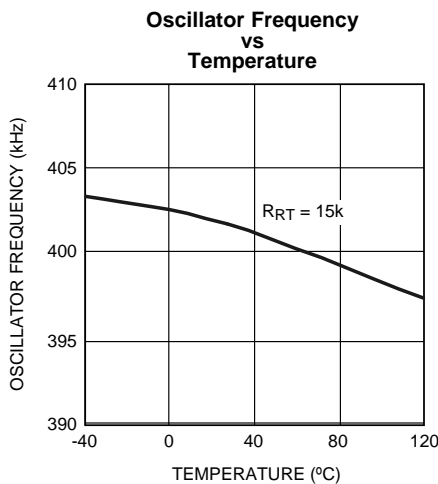

Figure 8.

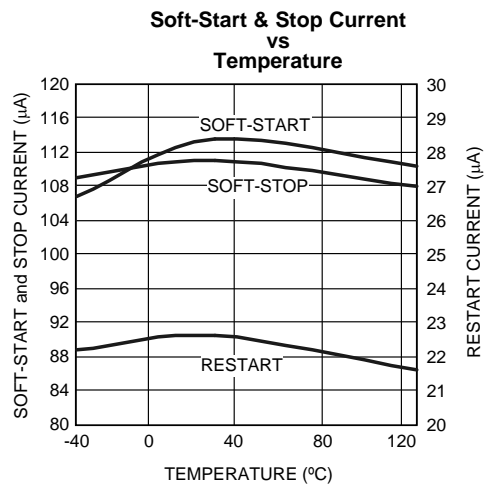

Figure 9.

Typical Performance Characteristics (continued)

Effective Comp Input Impedance

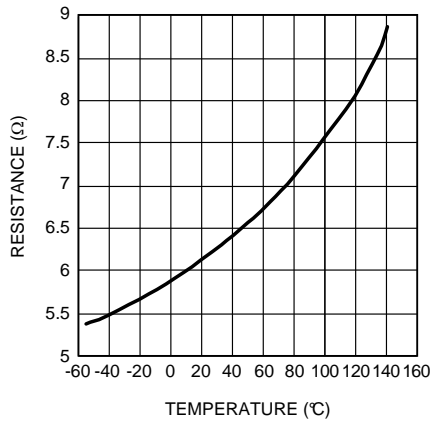

Figure 10.

R_{DLY} vs Deadtime

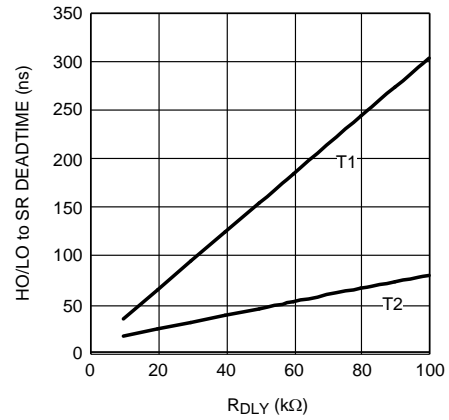

Figure 11.

SR "T1" Parameter vs Temperature

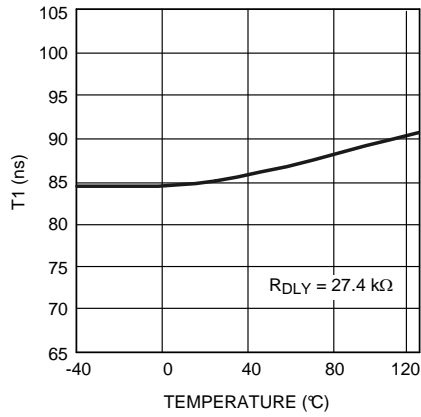

Figure 12.

SR "T2" Parameter vs Temperature

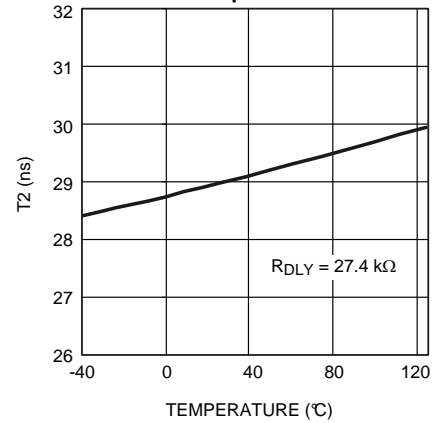
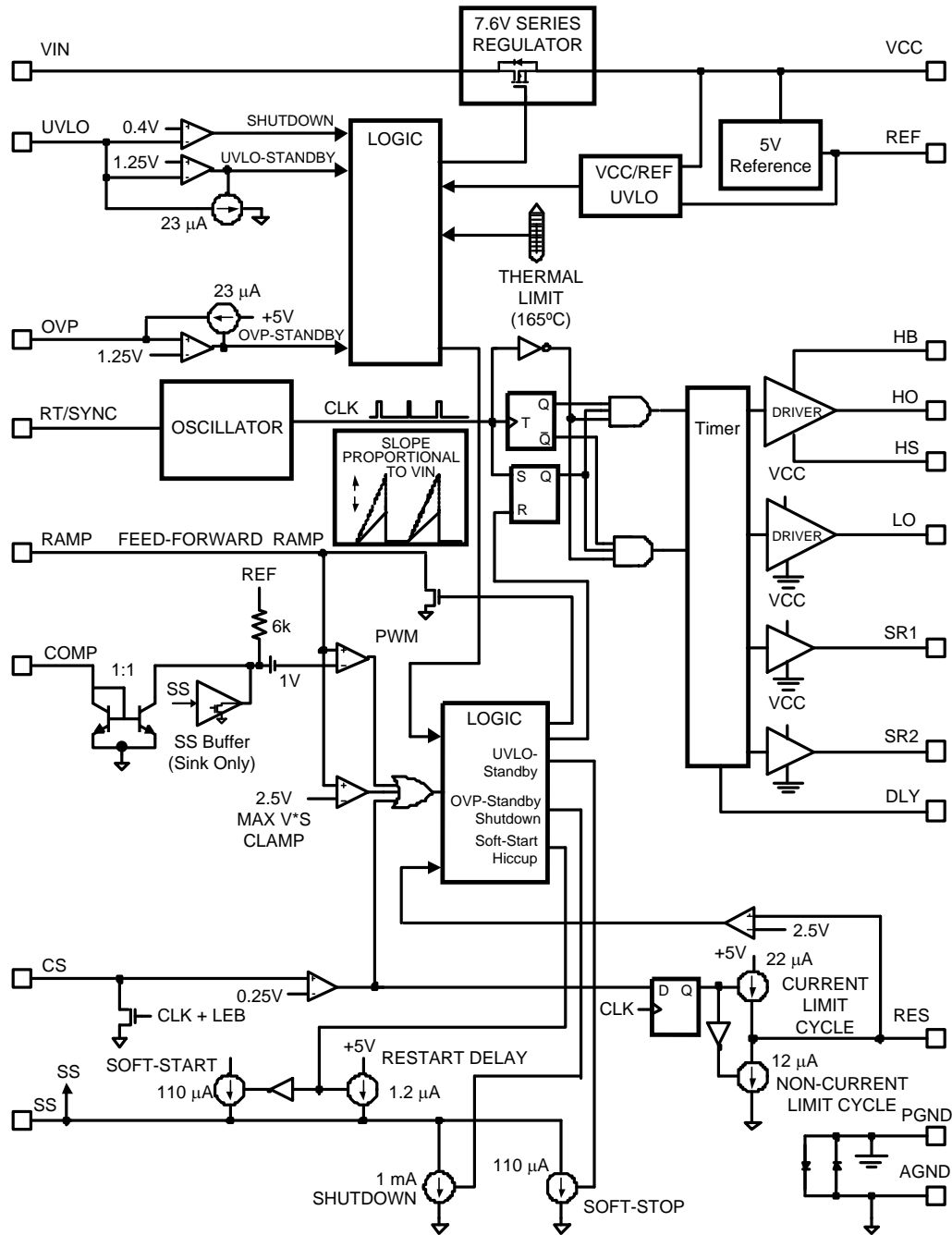

Figure 13.

Block Diagram



FUNCTIONAL DESCRIPTION

The LM5035A PWM controller contains all of the features necessary to implement half-bridge voltage-mode controlled power converters. The LM5035A provides two gate driver outputs to directly drive the primary side power MOSFETs and two signal level outputs to control secondary synchronous rectifiers through an isolation interface. Secondary side drivers, such as the LM5110, are typically used to provide the necessary gate drive current to control the sync MOSFETs. Synchronous rectification allows higher conversion efficiency and greater power density than conventional PN or Schottky rectifier techniques. The LM5035A can be configured to operate with bias voltages ranging from 8V to 105V. Additional features include line under-voltage lockout, cycle-by-cycle current limit, voltage feed-forward compensation, hiccup mode fault protection with adjustable delays, soft-start, a 2MHz capable oscillator with synchronization capability, precision reference, thermal shutdown and programmable volt-second clamping. These features simplify the design of voltage-mode half-bridge DC-DC power converters. The Functional Block Diagram is shown in [Block Diagram](#).

High-Voltage Start-up Regulator

The LM5035A contains an internal high voltage start-up regulator that allows the input pin (VIN) to be connected directly to a nominal 48 VDC input voltage. The regulator input can withstand transients up to 105V. The regulator output at VCC (7.6V) is internally current limited to 35 mA typical. When the UVLO pin potential is greater than 0.4V, the VCC regulator is enabled to charge an external capacitor connected to the VCC pin. The VCC regulator provides power to the voltage reference (REF) and the output drivers (LO, SR1 and SR2). When the voltage on the VCC pin exceeds the UVLO threshold of 7.6V, the internal voltage reference (REF) reaches its regulation setpoint of 5V and the UVLO voltage is greater than 1.25V, the controller outputs are enabled. The value of the VCC capacitor depends on the total system design, and its start-up characteristics. The recommended range of values for the VCC capacitor is 0.1 μ F to 100 μ F.

The VCC under-voltage comparator threshold is lowered to 6.2V (typical) after VCC reaches the regulation setpoint. If VCC falls below this value, the outputs are disabled, and the soft-start capacitor is discharged. If VCC increases above 7.6V, the outputs will be enabled and a soft-start sequence will commence.

The internal power dissipation of the LM5035A can be reduced by powering VCC from an external supply. In typical applications, an auxiliary transformer winding is connected through a diode to the VCC pin. This winding must raise the VCC voltage above 8.3V to shut off the internal start-up regulator. Powering VCC from an auxiliary winding improves efficiency while reducing the controller's power dissipation. The under-voltage comparator circuit will still function in this mode, requiring that VCC never falls below 6.2V during the start-up sequence.

During a fault mode, when the converter auxiliary winding is inactive, external current draw on the VCC line should be limited such that the power dissipated in the start-up regulator does not exceed the maximum power dissipation of the IC package.

An external DC bias voltage can be used instead of the internal regulator by connecting the external bias voltage to both the VCC and the VIN pins. The external bias must be greater than 8.3V to exceed the VCC UVLO threshold and less than the VCC maximum operating voltage rating (15V).

Line Under-Voltage Detector

The LM5035A contains a dual level Under-Voltage Lockout (UVLO) circuit. When the UVLO pin voltage is below 0.4V, the controller is in a low current shutdown mode. When the UVLO pin voltage is greater than 0.4V but less than 1.25V, the controller is in standby mode. In standby mode the VCC and REF bias regulators are active while the controller outputs are disabled. When the VCC and REF outputs exceed the VCC and REF under-voltage thresholds and the UVLO pin voltage is greater than 1.25V, the outputs are enabled and normal operation begins. An external set-point voltage divider from VIN to GND can be used to set the minimum operating voltage of the converter. The divider must be designed such that the voltage at the UVLO pin will be greater than 1.25V when VIN enters the desired operating range. UVLO hysteresis is accomplished with an internal 23 μ A current sink that is switched on or off into the impedance of the set-point divider. When the UVLO threshold is exceeded, the current sink is deactivated to quickly raise the voltage at the UVLO pin. When the UVLO pin voltage falls below the 1.25V threshold, the current sink is enabled causing the voltage at the UVLO pin to quickly fall. The hysteresis of the 0.4V shutdown comparator is internally fixed at 100 mV.

The UVLO pin can also be used to implement various remote enable / disable functions. Turning off a converter by forcing the UVLO pin to the standby condition provides a controlled soft-stop. See the [Soft-Start](#) section for more details.

Line Over Voltage / Load Over Voltage / Remote Thermal Protection

The LM5035A provides a multipurpose OVP pin that supports several fault protection functions. When the OVP pin voltage exceeds 1.25V, the controller is held in standby mode which immediately halts the PWM pulses at the HO and LO pins. In standby mode, the VCC and REF bias regulators are active while the controller outputs are disabled. When the OVP pin voltage falls below the 1.25V OVP threshold, the outputs are enabled and normal soft-start sequence begins. Hysteresis is accomplished with an internal 23 μ A current source that is switched on or off into the impedance of the OVP pin set-point divider. When the OVP threshold is exceeded, the current source is enabled to quickly raise the voltage at the OVP pin. When the OVP pin voltage falls below the 1.25V threshold, the current source is disabled causing the voltage at the OVP pin to quickly fall.

Several examples of the use of this pin are provided in the [Application Information](#) section.

Reference

The REF pin is the output of a 5V linear regulator that can be used to bias an opto-coupler transistor and external housekeeping circuits. The regulator output is internally current limited to 20mA (typical).

Cycle-by-Cycle Current Limit

The CS pin is driven by a signal representative of the transformer primary current. If the voltage sensed at CS pin exceeds 0.25V, the current sense comparator terminates the HO or LO output driver pulse. If the high current condition persists, the controller operates in a cycle-by-cycle current limit mode with duty cycle determined by the current sense comparator instead of the PWM comparator. Cycle-by-cycle current limiting may trigger the hiccup mode restart cycle depending on the configuration of the RES pin (see below).

A small R-C filter connect to the CS pin and located near the controller is recommended to suppress noise. An internal 32 Ω MOSFET connected to the CS input discharges the external current sense filter capacitor at the conclusion of every cycle. The discharge MOSFET remains on for an additional 50 ns after the HO or LO driver switches high to blank leading edge transients in the current sensing circuit. Discharging the CS pin filter each cycle and blanking leading edge spikes reduces the filtering requirements and improves the current sense response time.

The current sense comparator is very fast and responds to short duration noise pulses. Layout considerations are critical for the current sense filter and sense resistor. The capacitor associated with the CS filter must be placed very close to the device and connected directly to the CS and AGND pins. If a current sense transformer is used, both leads of the transformer secondary should be routed to the filter network, which should be located close to the IC. If a sense resistor located in the source of the main MOSFET switch is used for current sensing, a low inductance type of resistor is required. When designing with a current sense resistor, all of the noise sensitive low power ground connections should be connected together near the AGND pin, and a single connection should be made to the power ground (sense resistor ground point).

Overload Protection Timer

The LM5035A provides a current limit restart timer to disable the outputs and force a delayed restart (hiccup mode) if a current limit condition is repeatedly sensed. The number of cycle-by-cycle current limit events required to trigger the restart is programmable by the external capacitor at the RES pin. During each PWM cycle, the LM5035A either sources or sinks current from the RES pin capacitor. If no current limit is detected during a cycle, an 12 μ A discharge current sink is enabled to pull the RES pin to ground. If a current limit is detected, the 12 μ A sink current is disabled and a 22 μ A current source causes the voltage at the RES pin to gradually increase. The LM5035A protects the converter with cycle-by-cycle current limiting while the voltage at RES pin increases. If the RES voltage reaches the 2.5V threshold, the following restart sequence occurs (also see [Figure 14](#)):

- The RES capacitor and SS capacitors are fully discharged
- The soft-start current source is reduced from 110 μ A to 1 μ A
- The SS capacitor voltage slowly increases. When the SS voltage reaches \approx 1V, the PWM comparator will produce the first narrow output pulse. After the first pulse occurs, the SS source current reverts to the normal 110 μ A level. The SS voltage increases at its normal rate, gradually increasing the duty cycle of the output drivers

- If the overload condition persists after restart, cycle-by-cycle current limiting will begin to increase the voltage on the RES capacitor again, repeating the hiccup mode sequence
- If the overload condition no longer exists after restart, the RES pin will be held at ground by the 12 μA current sink and normal operation resumes

The overload timer function is very versatile and can be configured for the following modes of protection:

1. **Cycle-by-cycle only:** The hiccup mode can be completely disabled by connecting a zero to 50 k Ω resistor from the RES pin to AGND. In this configuration, the cycle-by-cycle protection will limit the output current indefinitely and no hiccup sequences will occur.
2. **Hiccup only:** The timer can be configured for immediate activation of a hiccup sequence upon detection of an overload by leaving the RES pin open circuit.
3. **Delayed Hiccup:** Connecting a capacitor to the RES pin provides a programmed interval of cycle-by-cycle limiting before initiating a hiccup mode restart, as previously described. The dual advantages of this configuration are that a short term overload will not cause a hiccup mode restart but during extended overload conditions, the average dissipation of the power converter will be very low.
4. **Externally Controlled Hiccup:** The RES pin can also be used as an input. By externally driving the pin to a level greater than the 2.5V hiccup threshold, the controller will be forced into the delayed restart sequence. For example, the external trigger for a delayed restart sequence could come from an over-temperature protection circuit or an output over-voltage sensor.

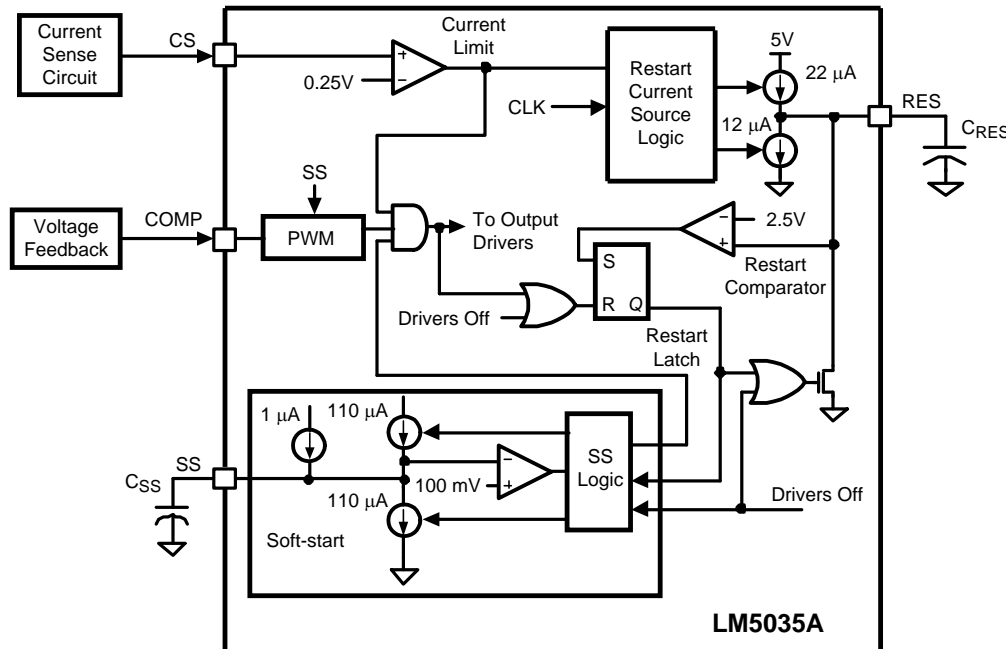

Figure 14. Current Limit Restart Circuit

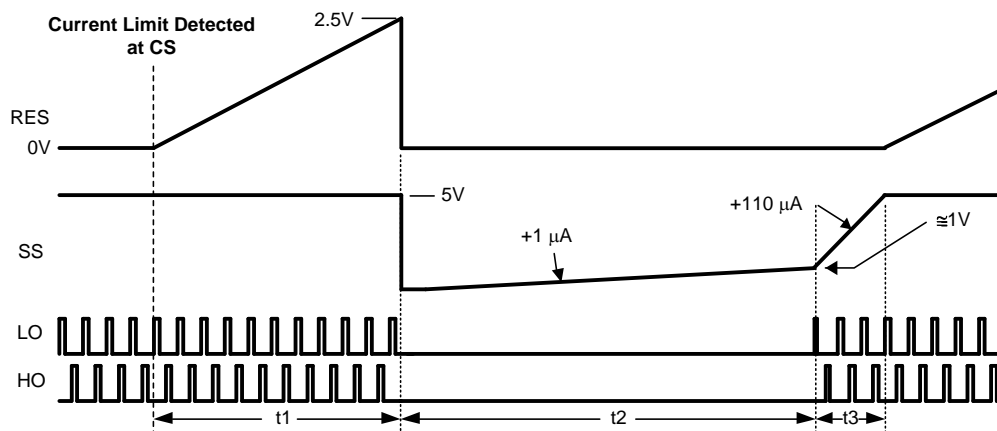

Figure 15. Current Limit Restart Timing

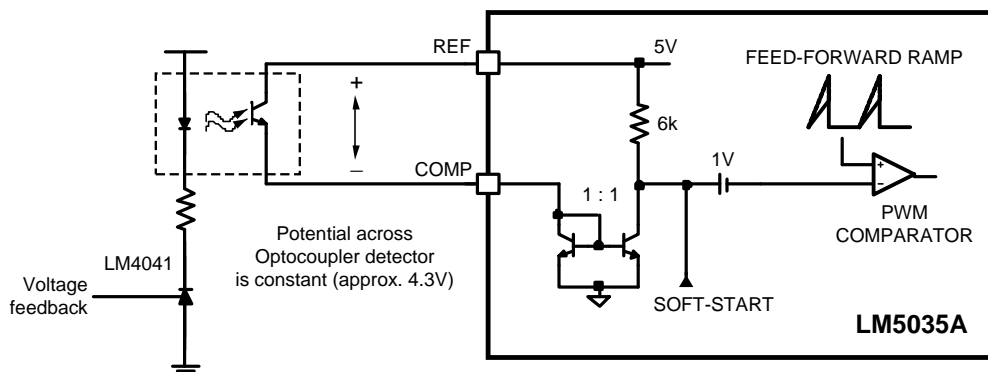

Figure 16. Optocoupler to COMP Interface

Soft-Start

The soft-start circuit allows the regulator to gradually reach a steady state operating point, thereby reducing start-up stresses and current surges. When bias is supplied to the LM5035A, the SS pin capacitor is discharged by an internal MOSFET. When the UVLO, VCC and REF pins reach their operating thresholds, the SS capacitor is released and charged with a 110 μA current source. The PWM comparator control voltage is clamped to the SS pin voltage by an internal amplifier. When the PWM comparator input reaches 1V, output pulses commence with slowly increasing duty cycle. The voltage at the SS pin eventually increases to 5V, while the voltage at the PWM comparator increases to the value required for regulation as determined by the voltage feedback loop.

One method to shutdown the regulator is to ground the SS pin. This forces the internal PWM control signal to ground, reducing the output duty cycle quickly to zero. Releasing the SS pin begins a soft-start cycle and normal operation resumes. A second shutdown method is discussed in the [UVLO](#) section.

Soft-Stop

If the UVLO pin voltage falls below the 1.25V standby threshold but above the 0.4V shutdown threshold, the 110 μ A SS pin source current is disabled and a 110 μ A sink current discharges the soft-start capacitor. As SS voltage falls and clamps the PWM comparator input, the PWM duty cycle will gradually fall to zero. The soft-stop feature produces a gradual reduction of the power converter output voltage. This soft-stop method of turning off the converter reduces energy in the output capacitor before control of the main and synchronous rectification MOSFETs is disabled. The PWM pulses may cease before the SS voltage reduces the duty cycle if the VCC or REF voltage drops below the respective under-voltage thresholds during the soft-stop process.

PWM Comparator

The pulse width modulation (PWM) comparator compares the voltage ramp signal at the RAMP pin to the loop error signal. This comparator is optimized for speed in order to achieve minimum controllable duty cycles. The loop error signal is received from the external feedback and isolation circuit in the form of a control current into the COMP pin. The COMP pin current is internally mirrored by a matched pair of NPN transistors which sink current through a 5 k Ω resistor connected to the 5V reference. The resulting control voltage passes through a 1V level shift before being applied to the PWM comparator.

An opto-coupler detector can be connected between the REF pin and the COMP pin. Because the COMP pin is controlled by a current input, the potential difference across the optocoupler detector is nearly constant. The bandwidth limiting phase delay which is normally introduced by the significant capacitance of the opto-coupler is thereby greatly reduced. Higher loop bandwidths can be realized since the bandwidth-limiting pole associated with the opto-coupler is now at a much higher frequency. The PWM comparator polarity is configured such that with no current into the COMP pin, the controller produces the maximum duty cycle at the main gate driver outputs, HO and LO.

Feed-Forward Ramp and Volt • Second Clamp

An external resistor (R_{FF}) and capacitor (C_{FF}) connected to VIN, AGND, and the RAMP pin are required to create the PWM ramp signal. The slope of the signal at RAMP will vary in proportion to the input line voltage. This varying slope provides line feed-forward information necessary to improve line transient response with voltage mode control. The RAMP signal is compared to the error signal by the pulse width modulator comparator to control the duty cycle of the HO and LO outputs. With a constant error signal, the on-time (T_{ON}) varies inversely with the input voltage (VIN) to stabilize the Volt • Second product of the transformer primary signal. The power path gain of conventional voltage-mode pulse width modulators (oscillator generated ramp) varies directly with input voltage. The use of a line generated ramp (input voltage feed-forward) nearly eliminates this gain variation. As a result, the feedback loop is only required to make very small corrections for large changes in input voltage.

In addition to the PWM comparator, a Volt • Second Clamp comparator also monitors the RAMP pin. If the ramp amplitude exceeds the 2.5V threshold of the Volt • Second Clamp comparator, the on-time is terminated. The C_{FF} ramp capacitor is discharged by an internal 32 Ω discharge MOSFET controlled by the V•S Clamp comparator. If the RAMP signal does not exceed 2.5V before the end of the clock period, then the internal clock will enable the discharge MOSFET to reset capacitor C_{FF} .

By proper selection of R_{FF} and C_{FF} values, the maximum on-time of HO and LO can be set to the desired duration. The on-time set by the Volt • Second Clamp varies inversely to the line voltage because the RAMP capacitor is charged by a resistor (R_{FF}) connected to VIN while the threshold of the clamp is a fixed voltage (2.5V). An example will illustrate the use of the Volt • Second Clamp comparator to achieve a 50% duty cycle limit at 200kHz with a 48V line input. A 50% duty cycle at a 200kHz requires a 2.5 μ s on-time. To achieve this maximum on-time clamp level:

$$R_{FF} \times C_{FF} = \frac{T_{ON} + 10\%}{\ln\left[\left(1 - \frac{2.5V}{VIN}\right)^{-1}\right]} = \frac{2.5 \mu s + 0.25 \mu s}{\ln\left[\left(1 - \frac{2.5V}{48V}\right)^{-1}\right]} = 51.4 \mu s \quad (1)$$

The recommended capacitor value range for C_{FF} is 100 pF to 1000 pF. 470 pF is a standard value that can be paired with an 110 k Ω to approximate the desired 51.4 μ s time constant. If load transient response is slowed by the 10% margin, the R_{FF} value can be increased. The system signal-to-noise will be slightly decreased by increasing $R_{FF} \times C_{FF}$.

Oscillator, Sync Capability

The LM5035A oscillator frequency is set by a single external resistor connected between the RT and AGND pins. To set a desired oscillator frequency, the necessary RT resistor is calculated from:

$$RT = \left(\frac{1}{F_{OSC}} - 110 \text{ ns} \right) \times 6.25 \times 10^9 \quad (2)$$

For example, if the desired oscillator frequency is 400kHz (HO and LO each switching at 200 kHz) a 15 kΩ resistor would be the nearest standard one percent value.

Each output (HO, LO, SR1 and SR2) switches at half the oscillator frequency. The voltage at the RT pin is internally regulated to a nominal 2V. The RT resistor should be located as close as possible to the IC, and connected directly to the pins (RT and AGND). The tolerance of the external resistor, and the frequency tolerance indicated in the [Electrical Characteristics](#), must be taken into account when determining the worst case frequency range.

The LM5035A can be synchronized to an external clock by applying a narrow pulse to the RT pin. The external clock must be at least 10% higher than the free-running oscillator frequency set by the RT resistor. If the external clock frequency is less than the RT resistor programmed frequency, the LM5035A will ignore the synchronizing pulses. The synchronization pulse width at the RT pin must be a minimum of 15 ns wide. The clock signal should be coupled into the RT pin through a 100 pF capacitor or a value small enough to ensure the pulse width at RT is less than 60% of the clock period under all conditions. When the synchronizing pulse transitions low-to-high (rising edge), the voltage at the RT pin must be driven to exceed 3.2V volts from its nominal 2 VDC level. During the clock signal's low time, the voltage at the RT pin will be clamped at 2 VDC by an internal regulator. The output impedance of the RT regulator is approximately 100Ω. The RT resistor is always required, whether the oscillator is free running or externally synchronized.

Gate Driver Outputs (HO & LO)

The LM5035A provides two alternating gate driver outputs, the floating high side gate driver HO and the ground referenced low side driver LO. Each driver is capable of sourcing 1.25A and sinking 2A peak. The HO and LO outputs operate in an alternating manner, at one-half the internal oscillator frequency. The LO driver is powered directly by the VCC regulator. The HO gate driver is powered from a bootstrap capacitor connected between HB and HS. An external diode connected between VCC (anode pin) and HB (cathode pin) provides the high side gate driver power by charging the bootstrap capacitor from VCC when the switch node (HS pin) is low. When the high side MOSFET is turned on, HB rises to a peak voltage equal to $V_{VCC} + V_{HS}$ where V_{HS} is the switch node voltage.

The HB and VCC capacitors should be placed close to the pins of the LM5035A to minimize voltage transients due to parasitic inductances since the peak current sourced to the MOSFET gates can exceed 1.25A. The recommended value of the HB capacitor is 0.01 μF or greater. A low ESR / ESL capacitor, such as a surface mount ceramic, should be used to prevent voltage droop during the HO transitions.

The maximum duty cycle for each output is limited to slightly less than 50% due to the internally fixed deadtime and any programmed sync rectifier delay. The typical deadtime in this condition is 70 ns. The programmed sync rectifier delay is determined by the DLY pin resistor. If the COMP pin is open circuit, the outputs will operate at maximum duty cycle. The maximum duty cycle for each output can be calculated with the following equation:

$$\text{Maximum Duty Cycle} = \frac{\frac{1}{2}T_S - T_D - T_1}{T_S} \quad (3)$$

Where T_S is the period of one complete cycle for either the HO or LO outputs, T_D is the internally fixed deadtime, and T_1 is the programmed sync rectifier delay. For example, if the oscillator frequency is 200 kHz, each output will cycle at 100 kHz ($T_S = 10 \mu\text{s}$). Using the nominal deadtime of 70 ns and no programmed delay, the maximum duty cycle at this frequency is calculated to be 49.3%. Using a programmed sync rectifier delay of 100 ns, the maximum duty cycle is reduced to 48.3%.

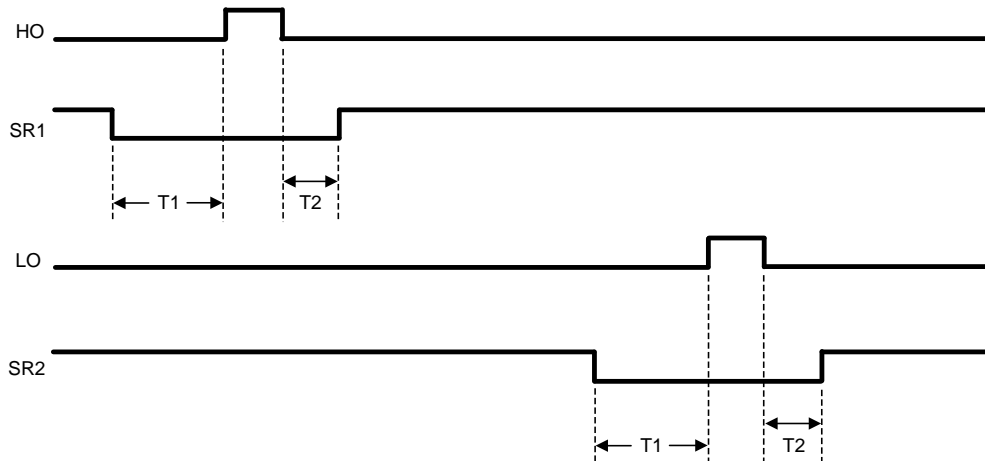

Figure 17. HO, LO, SR1 and SR2 Timing Diagram

Synchronous Rectifier Control Outputs (SR1 & SR2)

Synchronous rectification (SR) of the transformer secondary provides higher efficiency, especially for low output voltage converters. The reduction of rectifier forward voltage drop (0.5V - 1.5V) to 10mV - 200mV V_{DS} voltage for a MOSFET significantly reduces rectification losses. In a typical application, the transformer secondary winding is center tapped, with the output power inductor in series with the center tap. The SR MOSFETs provide the ground path for the energized secondary winding and the inductor current. Figure 17 shows that the SR2 MOSFET is conducting while HO enables power transfer from the primary. The SR1 MOSFET must be disabled during this period since the secondary winding connected to the SR1 MOSFET drain is twice the voltage of the center tap. At the conclusion of the HO pulse, the inductor current continues to flow through the SR1 MOSFET body diode. Since the body diode causes more loss than the SR MOSFET, efficiency can be improved by minimizing the T2 period while maintaining sufficient timing margin over all conditions (component tolerances, etc.) to prevent shoot-through current. When LO enables power transfer from the primary, the SR1 MOSFET is enabled and the SR2 MOSFET is off.

During the time that neither HO nor LO is active, the inductor current is shared between both the SR1 and SR2 MOSFETs which effectively shorts the transformer secondary and cancels the inductance in the windings. The SR2 MOSFET is disabled before LO delivers power to the secondary to prevent power being shunted to ground. The SR2 MOSFET body diode continues to carry about half the inductor current until the primary power raises the SR2 MOSFET drain voltage and reverse biases the body diode. Ideally, dead-time T1 would be set to the minimum time that allows the SR MOSFET to turn off before the SR MOSFET body diode starts conducting.

The SR1 and SR2 outputs are powered directly by the VCC regulator. Each output is capable of sourcing and sinking 0.5A peak. Typically, the SR1 and SR2 signals control SR MOSFET gate drivers through a pulse transformer. The actual gate sourcing and sinking currents are provided by the secondary-side bias supply and gate drivers.

The timing of SR1 and SR2 with respect to HO and LO is shown in Figure 17. SR1 is configured out of phase with HO and SR2 is configured out of phase with LO. The deadtime between transitions is programmable by a resistor connected from the DLY pin to the AGND pin. Typically, R_{DLY} is set in the range of 10k Ω to 100k Ω . The deadtime periods can be calculated using the following formulae:

$$T1 = .003 \times R_{DLY} + 4.6 \text{ ns} \quad (4)$$

$$T2 = .0007 \times R_{DLY} + 10.01 \text{ ns} \quad (5)$$

To set the minimum (propagation delays only) deadtime, the DLY pin should be left open or connected to the REF pin. Any resistor value above 300k Ω connected between the DLY pin and AGND will also provide the minimum period (approximately 5 ns).

Thermal Protection

Internal Thermal Shutdown circuitry is provided to protect the integrated circuit in the event the maximum rated junction temperature is exceeded. When activated, typically at 165°C, the controller is forced into a low power standby state with the output drivers (HO, LO, SR1 and SR2), the bias regulators (VCC and REF) disabled. This helps to prevent catastrophic failures from accidental device overheating. During thermal shutdown, the soft-start capacitor is fully discharged and the controller follows a normal start-up sequence after the junction temperature falls to the operating level (145°C).

Applications Information

The following information is intended to provide guidelines for the power supply designer using the LM5035A.

VIN

The voltage applied to the VIN pin, which may be the same as the system voltage applied to the power transformer's primary (V_{PWR}), can vary in the range of 13 to 105V. The current into VIN depends primarily on the gate charge provided to the output drivers, the switching frequency, and any external loads on the VCC and REF pins. It is recommended the filter shown in [Figure 18](#) be used to suppress transients which may occur at the input supply. This is particularly important when VIN is operated close to the maximum operating rating of the LM5035A.

When power is applied to VIN and the UVLO pin voltage is greater than 0.4V, the VCC regulator is enabled and supplies current into an external capacitor connected to the VCC pin. When the voltage on the VCC pin reaches the regulation point of 7.6V, the voltage reference (REF) is enabled. The reference regulation set point is 5V. The HO, LO, SR1 and SR2 outputs are enabled when the two bias regulators reach their set point and the UVLO pin potential is greater than 1.25V. In typical applications, an auxiliary transformer winding is connected through a diode to the VCC pin. This winding must raise the VCC voltage above 8.3V to shut off the internal start-up regulator.

After the outputs are enabled and the external VCC supply voltage has begun supplying power to the IC, the current into VIN drops below 1 mA. VIN should remain at a voltage equal to or above the VCC voltage to avoid reverse current through protection diodes.

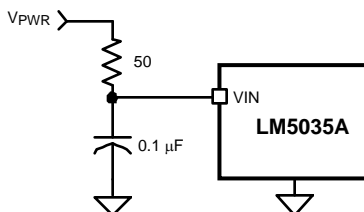

Figure 18. Input Transient Protection

FOR APPLICATIONS >100V

For applications where the system input voltage exceeds 100V or the IC power dissipation is of concern, the LM5035A can be powered from an external start-up regulator as shown in [Figure 19](#). In this configuration, the VIN and the VCC pins should be connected together, which allows the LM5035A to be operated below 13V. The voltage at the VCC pin must be greater than 8.3V yet not exceed 15V. An auxiliary winding can be used to reduce the power dissipation in the external regulator once the power converter is active. The NPN base-emitter reverse breakdown voltage, which can be as low as 5V for some transistors, should be considered when selecting the transistor.

CURRENT SENSE

The CS pin needs to receive an input signal representative of the transformer's primary current, either from a current sense transformer or from a resistor in series with the source of the LO switch, as shown in [Figure 20](#) and [Figure 21](#). In both cases, the sensed current creates a ramping voltage across R1, and the R_F/C_F filter suppresses noise and transients. R1, R_F and C_F should be located as close to the LM5035A as possible, and the ground connection from the current sense transformer, or R1, should be a dedicated track to the AGND pin. The current sense components must provide greater than 0.25V at the CS pin when an over-current condition exists.

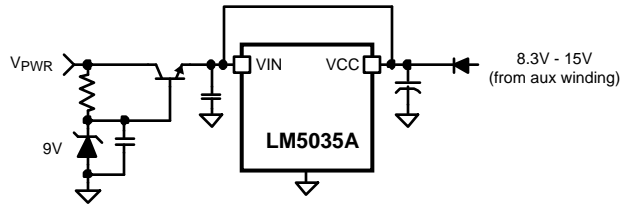

Figure 19. Start-up Regulator for $V_{PWR} > 100V$

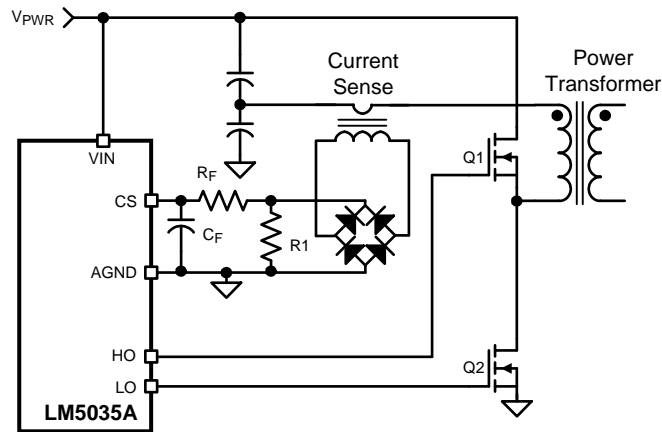

Figure 20. Current Sense Using Current Sense Transformer

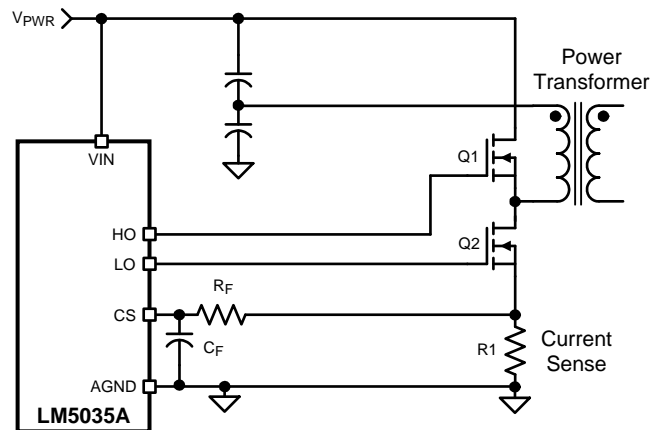

Figure 21. Current Sense Using Current Sense Resistor (R1)

If the current sense resistor method is used, the over-current condition will only be sensed while LO is driving the low-side MOSFET. Over-current while HO is driving the high-side MOSFET will not be detected. In this configuration, it will take 4 times as long for continuous cycle-by-cycle current limiting to initiate a restart event since each over-current event during LO enables the 22µA RES pin current source for one oscillator period, and then the lack of an over-current event during HO enables the 12µA RES pin current sink for one oscillator period. The time average of this toggling is equivalent to a continuous 5 µA current source into the RES capacitor, increasing the delay by a factor of four. The value of the RES capacitor can be reduced to decrease the time before restart cycle is initiated.

When using the resistor current sense method, an imbalance in the input capacitor voltages may develop when operating in cycle-by-cycle current limiting mode. If the imbalance persists for an extended period, excessive currents in the non-sensed MOSFET, and possible transformer saturation may result. This condition is inherent to the half-bridge topology operated with cycle-by-cycle current limiting and is compounded by only sensing in one leg of the half-bridge circuit. The imbalance is greatest at large duty cycles (low input voltages). If using this method, it is recommended that the capacitor on the RES pin be no larger than 220 pF. Check the final circuit and reduce the RES capacitor further, or omit the capacitor completely to ensure the voltages across the bridge capacitors remain balanced. The current limit value may decrease slightly as the RES capacitor is reduced.

HO, HB, HS and LO

Attention must be given to the PC board layout for the low-side driver and the floating high-side driver pins HO, HB and HS. A low ESR/ESL capacitor (such as a ceramic surface mount capacitor) should be connected close to the LM5035A, between HB and HS to provide high peak currents during turn-on of the high-side MOSFET. The capacitor should be large enough to supply the MOSFET gate charge (Qg) without discharging to the point where the drop in gate voltage affects the MOSFET R_{DS(ON)}. A value ten to twenty times Qg is recommended.

$$C_{\text{BOOST}} = 20 \times \frac{Q_g}{V_{\text{CC}}} \quad (6)$$

The diode (D_{BOOST}) that charges C_{BOOST} from VCC when the low-side MOSFET is conducting should be capable of withstanding the full converter input voltage range. When the high-side MOSFET is conducting, the reverse voltage at the diode is approximately the same as the MOSFET drain voltage because the high-side driver is boosted up to the converter input voltage by the HS pin, and the high side MOSFET gate is driven to the HS voltage plus VCC. Since the anode of D_{BOOST} is connected to VCC, the reverse potential across the diode is equal to the input voltage minus the VCC voltage. D_{BOOST} average current is less than 20mA in most applications, so a low current ultra-fast recovery diode is recommended to limit the loss due to diode junction capacitance. Schottky diodes are also a viable option, particularly for lower input voltage applications, but attention must be paid to leakage currents at high temperatures.

The internal gate drivers need a very low impedance path to the respective decoupling capacitors; the VCC cap for the LO driver and C_{BOOST} for the HO driver. These connections should be as short as possible to reduce inductance and as wide as possible to reduce resistance. The loop area, defined by the gate connection and its respective return path, should be minimized.

The high-side gate driver can also be used with HS connected to PGND for applications other than a half bridge converter (e.g. Push-Pull). The HB pin is then connected to VCC, or any supply greater than the high-side driver undervoltage lockout (approximately 6.5V). In addition, the high-side driver can be configured for high voltage offline applications where the high-side MOSFET gate is driven via a gate drive transformer.

PROGRAMMABLE DELAY (DLY)

The R_{DLY} resistor programs the delays between the SR1 and SR2 signals and the HO and LO driver outputs. [Figure 17](#) shows the relationship between these outputs. The DLY pin is nominally set at 2.5V and the current is sensed through R_{DLY} to ground. This current is used to adjust the amount of deadtime before the HO and LO pulse (T1) and after the HO and LO pulse (T2). Typically R_{DLY} is in the range of 10kΩ to 100kΩ. The deadtime periods can be calculated using the following formulae:

$$T1 = .003 \times R_{\text{DLY}} + 4.6 \text{ ns} \quad (7)$$

$$T2 = .0007 \times R_{\text{DLY}} + 10.01 \text{ ns} \quad (8)$$

T1 and T2 can be set to minimum by not connecting a resistor to DLY, connecting a resistor greater than 300kΩ from DLY to ground, or connecting DLY to the REF pin. This may cause lower than optimal system efficiency if the delays through the SR signal transformer network, the secondary gate drivers and the SR MOSFETs are greater than the delay to turn on the HO or LO MOSFETs. Should an SR MOSFET remain on while the opposing primary MOSFET is supplying power through the power transformer, the secondary winding will experience a momentary short circuit, causing a significant power loss to occur.

When choosing the R_{DLY} value, worst case propagation delays and component tolerances should be considered to assure that there is never a time where both SR MOSFETs are enabled AND one of the primary side MOSFETs is enabled. The time period T1 should be set so that the SR MOSFET has turned off before the primary MOSFET is enabled. Conversely, T1 and T2 should be kept as low as tolerances allow to optimize efficiency. The SR body diode conducts during the time between the SR MOSFET turns off and the power transformer begins supplying energy. Power losses increase when this happens since the body diode voltage drop is many times higher than the MOSFET channel voltage drop. The interval of body diode conduction can be observed with an oscilloscope as a negative 0.7V to 1.5V pulse at the SR MOSFET drain.

UVLO AND OVP VOLTAGE DIVIDER SELECTION FOR R1, R2, AND R3

Two dedicated comparators connected to the UVLO and OVP pins are used to detect under-voltage and over-voltage conditions. The threshold value of these comparators, V_{UVLO} and V_{OVP} , is 1.25V (typical). The two functions can be programmed independently with two voltage dividers from V_{IN} to AGND as shown in Figure 22 and Figure 23, or with a three-resistor divider as shown in Figure 24. Independent UVLO and OVP pins provide greater flexibility for the user to select the operational voltage range of the system. Hysteresis is accomplished by 23 μ A current sources (I_{UVLO} and I_{OVP}), which are switched on or off into the sense pin resistor dividers as the comparators change state.

When the UVLO pin voltage is below 0.4V, the controller is in a low current shutdown mode. For a UVLO pin voltage greater than 0.4V but less than 1.25V the controller is in standby mode. Once the UVLO pin voltage is greater than 1.25V, the controller is fully enabled. Two external resistors can be used to program the minimum operational voltage for the power converter as shown in Figure 22. When the UVLO pin voltage falls below the 1.25V threshold, an internal 23 μ A current sink is enabled to lower the voltage at the UVLO pin, thus providing threshold hysteresis. Resistance values for R1 and R2 can be determined from the following equations.

$$R_1 = \frac{V_{HYS}}{23 \mu A} \quad (9)$$

$$R_2 = \frac{1.25V \times R_1}{V_{PWR} - 1.25V - (23 \mu A \times R_1)} \quad (10)$$

where V_{PWR} is the desired turn-on voltage and V_{HYS} is the desired UVLO hysteresis at V_{PWR} .

For example, if the LM5035A is to be enabled when V_{PWR} reaches 34V, and disabled when V_{PWR} is decreased to 32V, R1 should be 87 kΩ, and R2 should be 3.54kΩ. The voltage at the UVLO pin should not exceed 7V at any time. Be sure to check both the power and voltage rating (0603 resistors can be rated as low as 50V) for the selected R1 resistor.

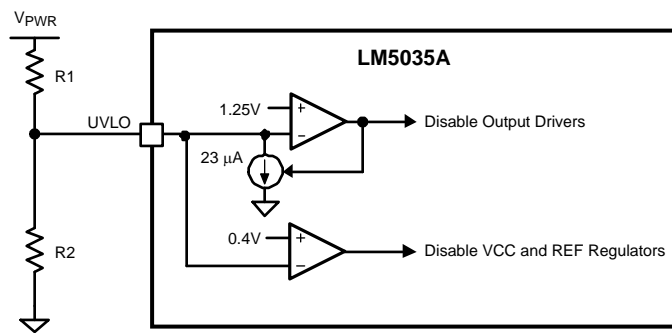

Figure 22. Basic UVLO Configuration

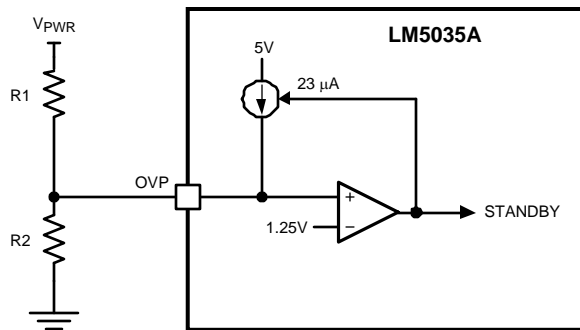

Figure 23. Basic Over-Voltage Protection

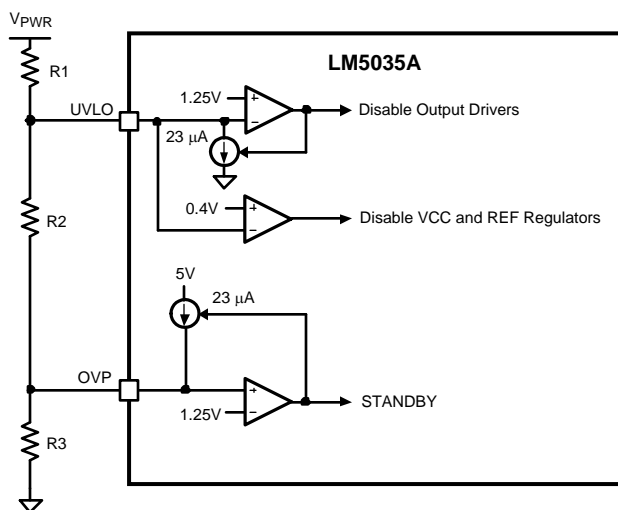

Figure 24. UVLO/OVP Divider

The impedance seen looking into the resistor divider from the UVLO and OVP pins determines the hysteresis level. UVLO and OVP enable and disable thresholds are calculated using the equations in the table below for the three-resistor divider illustrated in [Figure 24](#).

Table 1. UVLO/OVP Divider Formulas

| | | |
|--|--|------|
| Outputs disabled due to VIN falling below UVLO threshold | $UVLO_{off} = 1.25V \times \left(\frac{R_1 + R_2 + R_3}{R_2 + R_3} \right)$ | (11) |
| Outputs enabled due to VIN rising above UVLO threshold | $UVLO_{on} = UVLO_{off} + (23 \mu A \times R_1)$ | |
| Outputs disabled due to VIN rising above OVP threshold | $OVP_{off} = 1.25V \times \left(\frac{R_1 + R_2 + R_3}{R_3} \right)$ | (12) |
| Outputs enabled due to VIN falling below OVP threshold | $OVP_{on} = OVP_{off} - [23 \mu A \times (R_1 + R_2)]$ | |

The typical operating ranges of undervoltage and overvoltage thresholds are calculated from the above equations. For example, for resistor values $R_1 = 86.6k\Omega$, $R_2 = 2.10k\Omega$ and $R_3 = 1.40k\Omega$ the computed thresholds are:

UVLO turn-off = 32.2V

UVLO turn-on = 34.2V

OVP turn-on = 78.4V

OVP turn-off = 80.5V

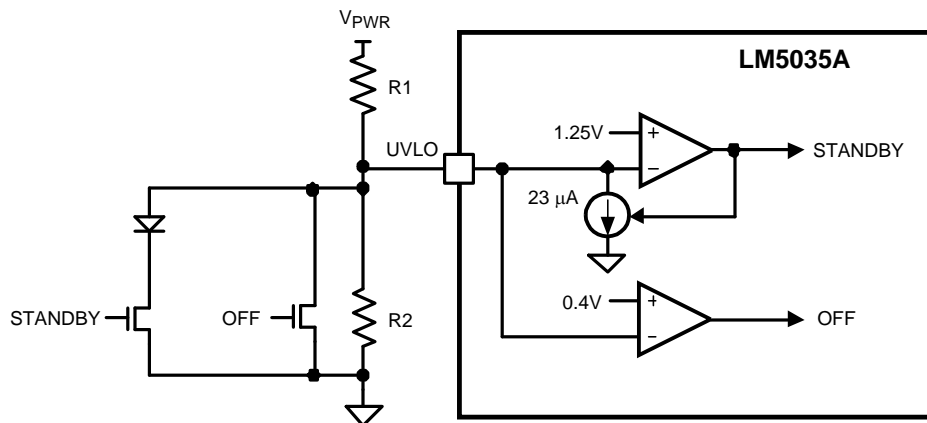
**Figure 25. Remote Standby and Disable Control**

To maintain the threshold's accuracy, a resistor tolerance of 1% or better is recommended.

The design process starts with the choice of the voltage difference between the UVLO enabling and disabling thresholds. This will also approximately set the difference between OVP enabling and disabling regulation:

$$R_1 = \frac{UVLO_{on} - UVLO_{off}}{23 \mu A} \quad (13)$$

Next, the combined resistance of R_2 and R_3 is calculated by choosing the threshold for the UVLO disabling threshold:

$$R_{COMBINED} = \frac{1.25V \times R_1}{UVLO_{off} - 1.25V} \quad (14)$$

Then R_3 is determined by selecting the OVP disabling threshold:

$$R_3 = \frac{1.25V \times (R_1 + R_{COMBINED})}{OVP_{off}} \quad (15)$$

Finally, R_3 is subtracted from $R_{COMBINED}$ to give R_2 :

$$R_2 = R_{COMBINED} - R_3 \quad (16)$$

Remote configuration of the controller's operational modes can be accomplished with open drain device(s) connected to the UVLO pin as shown in Figure 25.

FAULT PROTECTION

The Over Voltage Protection (OVP) comparator of the LM5035A can be configured for line or load fault protection or thermal protection using an external temperature sensor or thermistor. Figure 23 shows a line over voltage shutdown application using a voltage divider between the input power supply, V_{PWR} , and AGND to monitor the line voltage.

Figure 26 demonstrates the use of the OVP pin for latched output over-voltage fault protection, using a zener and opto-coupler. When V_{OUT} exceeds the conduction threshold of the opto-coupler diode and zener, the opto-coupler momentarily turns on Q1 and the LM5035A enters standby mode, disabling the drivers and enabling the hysteresis current source on the OVP pin. Once the current source is enabled, the OVP voltage will remain at 2.3V ($23\ \mu\text{A} \times 100\ \text{k}\Omega$) without additional drive from the external circuit. If the opto-coupler transistor emitter were directly connected to the OVP pin, then leakage current in the zener diode amplified by the opto-coupler's gain could falsely trip the protection latch. R1 and Q1 are added reduce the sensitivity to low level currents in the opto-coupler. Using the values of Figure 26, the opto-coupler collector current must equal $V_{BE(Q1)} / R1 = 350\ \mu\text{A}$ before OVP latches. Once the controller has switched to standby mode, the outputs no longer switch but the VCC and REF regulators continue functioning and supply bias to the external circuitry. VCC must fall below 6.2V or the UVLO pin must fall below 0.4V to clear the OVP latch.

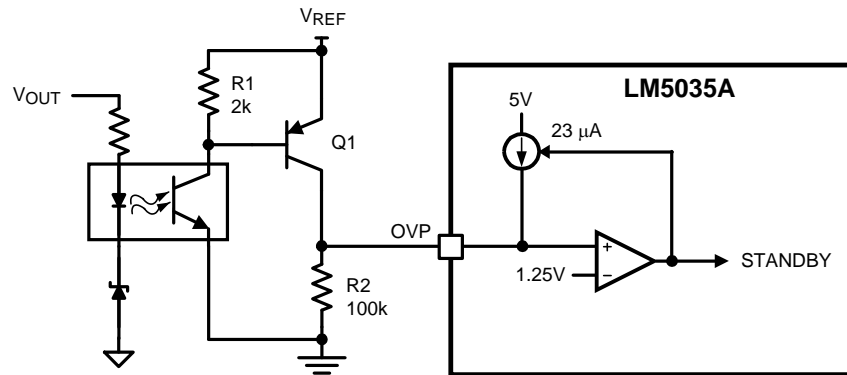

Figure 26. Latched Load Over-Voltage Protection

Figure 27 shows an application of the OVP comparator for Remote Thermal Protection using a thermistor (or multiple thermistors) which may be located near the main heat sources of the power supply. The negative temperature coefficient (NTC) thermistor is nearly logarithmic, and in this example a 100k Ω thermistor with the β material constant of 4500 kelvins changes to approximately 2 k Ω at 130 $^{\circ}\text{C}$. Setting R1 to one-third of this resistance (665 Ω) establishes 130 $^{\circ}\text{C}$ as the desired trip point (for $V_{REF} = 5\text{V}$). In a temperature band from 20 $^{\circ}\text{C}$ below to 20 $^{\circ}\text{C}$ above the OVP threshold, the voltage divider is nearly linear with 25 mV per $^{\circ}\text{C}$ sensitivity.

R2 provides temperature hysteresis by raising the OVP comparator input by $R2 \times 23\ \mu\text{A}$. For example, if a 22k Ω resistor is selected for R2, then the OVP pin voltage will increase by $22\ \text{k}\Omega \times 23\ \mu\text{A} = 506\ \text{mV}$. The NTC temperature must therefore fall by $506\ \text{mV} / 25\ \text{mV per}^{\circ}\text{C} = 20^{\circ}\text{C}$ before the LM5035A switches from the standby mode to the normal mode.

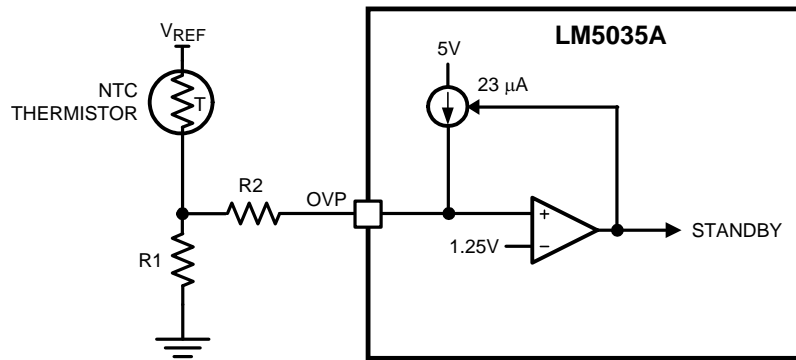

Figure 27. Remote Thermal Protection

HICCUP MODE CURRENT LIMIT RESTART (RES)

The basic operation of the hiccup mode current limit restart is described in the [functional description](#). The delay time to restart is programmed with the selection of the RES pin capacitor C_{RES} as illustrated in [Figure 27](#).

In the case of continuous cycle-by-cycle current limit detection at the CS pin, the time required for C_{RES} to reach the 2.5V hiccup mode threshold is:

$$t_1 = \frac{C_{RES} \times 2.5V}{22 \mu A} = 114 \text{ k}\Omega \times C_{RES} \quad (17)$$

For example, if $C_{RES} = 0.01 \mu\text{F}$ the time t_1 is approximately 1.14 ms.

The cool down time, t_2 is set by the soft-start capacitor (C_{SS}) and the internal $1 \mu\text{A}$ SS current source, and is equal to:

$$t_2 = \frac{C_{SS} \times 1V}{1 \mu A} = 1 \text{ M}\Omega \times C_{SS} \quad (18)$$

If $C_{SS} = 0.01 \mu\text{F}$ t_2 is ≈ 10 ms.

The soft-start time t_3 is set by the internal $110 \mu\text{A}$ current source, and is equal to:

$$t_3 = \frac{C_{SS} \times 4V}{110 \mu A} = 40 \text{ k}\Omega \times C_{SS} \quad (19)$$

If $C_{SS} = 0.01 \mu\text{F}$ t_3 is $\approx 363 \mu\text{s}$.

The time t_2 provides a periodic cool-down time for the power converter in the event of a sustained overload or short circuit. This off time results in lower average input current and lower power dissipation within the power components. It is recommended that the ratio of $t_2 / (t_1 + t_3)$ be in the range of 5 to 10 to take advantage of this feature.

If the application requires no delay from the first detection of a current limit condition to the onset of the hiccup mode ($t_1 = 0$), the RES pin can be left open (no external capacitor). If it is desired to disable the hiccup mode entirely, the RES pin should be connected to ground (AGND).

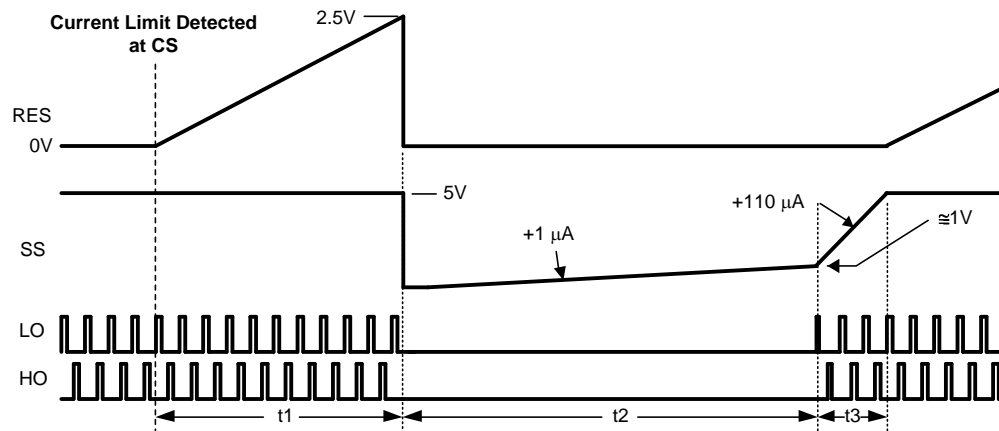

Figure 28. Hiccup Over-Load Restart Timing

Printed Circuit Board Layout

The LM5035A Current Sense and PWM comparators are very fast, and respond to short duration noise pulses. The components at the CS, COMP, SS, OVP, UVLO, DLY and the RT pins should be as physically close as possible to the IC, thereby minimizing noise pickup on the PC board tracks.

Layout considerations are critical for the current sense filter. If a current sense transformer is used, both leads of the transformer secondary should be routed to the sense filter components and to the IC pins. The ground side of the transformer should be connected via a dedicated PC board track to the AGND pin, rather than through the ground plane.

If the current sense circuit employs a sense resistor in the drive transistor source, low inductance resistors should be used. In this case, all the noise sensitive, low-current ground tracks should be connected in common near the IC, and then a single connection made to the power ground (sense resistor ground point).

The gate drive outputs of the LM5035A should have short, direct paths to the power MOSFETs in order to minimize inductance in the PC board traces. The SR control outputs should also have minimum routing distance through the pulse transformers and through the secondary gate drivers to the sync FETs.

The two ground pins (AGND, PGND) must be connected together with a short, direct connection, to avoid jitter due to relative ground bounce.

If the internal dissipation of the LM5035A produces high junction temperatures during normal operation, the use of multiple vias under the IC to a ground plane can help conduct heat away from the IC. Judicious positioning of the PC board within the end product, along with use of any available air flow (forced or natural convection) will help reduce the junction temperatures. If using forced air cooling, avoid placing the LM5035A in the airflow shadow of tall components, such as input capacitors.

Application Circuit Example

The following schematic shows an example of a 100W half-bridge power converter controlled by the LM5035A. The operating input voltage range (V_{PWR}) is 36V to 75V, and the output voltage is 3.3V. The output current capability is 30 Amps. Current sense transformer T2 provides information to the CS pin for current limit protection. The error amplifier and reference, U3 and U5 respectively, provide voltage feedback via opto-coupler U4. Synchronous rectifiers Q4, Q5, Q6 and Q7 minimize rectification losses in the secondary. An auxiliary winding on transformer T1 provides power to the LM5035A VCC pin when the output is in regulation. The input voltage UVLO thresholds are $\approx 34V$ for increasing V_{PWR} , and $\approx 32V$ for decreasing V_{PWR} . The circuit can be shut down by driving the ON/OFF input (J2) below 1.25V with an open-collector or open-drain circuit. An external synchronizing frequency can be applied through a 100pF capacitor to the RT input (U1 pin 5). The regulator output is current limited at $\approx 34A$.

Table 2. Differences between LM5035, LM5035A, LM5035A-1, LM5035B, and LM5035C⁽¹⁾⁽²⁾

| Performance Feature: | LM5035 | LM5035A | LM5035A-1 | LM5035B | LM5035C |
|--|-----------------------|-----------------------|----------------|-----------------------|-----------------------|
| Sync Rectifier Dead-time Ratio (T1:T2) | 2:1 | 3:1 | 3:1 | 3:1 | 3:1 |
| Soft-start: Hiccup Mode Charging Current | 50µA:1µA | 100µA:1µA | 100µA:1µA | 100µA:1µA | 100µA:1µA |
| Bootstrap (HB-HS) Under-Voltage Lockout | 5V | 3.9V | 3.9V | 3.9V | 3.9V |
| Start-up Regulator Current | 20mA (min) | 25mA (min) | 25mA (min) | 40mA (min) | 40mA (min) |
| SR State in UVLO Shutdown and Hiccup Current Limit | High | High | High | Low | Low |
| HO,LO On-Time at Max Duty Cycle | 0.5*T-T1-70 ns | 0.5*T-T1-70 ns | 0.5*T-T1-70 ns | 0.5*T-T1 | 0.5*T-T1 |
| Soft-Stop after UVLO | HO,LO | Yes | Yes | Yes | No |
| | SR1,2 | Yes | Yes | Yes | No |
| SR1, SR2 VOH (high state output) | VCC | VCC | VCC | VCC | REF (5V) |
| Package | HTSSOP-20, WQFN-24 | HTSSOP-20, WQFN-24 | HTSSOP-28 | HTSSOP-20, WQFN-24 | HTSSOP-20, WQFN-24 |

(1) T1 = Delay from SR1, SR2 to leading edge of HO, LO

(2) T = Period of HO or LO

REVISION HISTORY

| Changes from Revision E (April 2013) to Revision F | Page |
|--|--------------------|
| • Changed layout of National Data Sheet to TI format | 29 |

PACKAGING INFORMATION

| Orderable Device | Status (1) | Package Type | Package Drawing | Pins | Package Qty | Eco Plan (2) | Lead/Ball Finish (6) | MSL Peak Temp (3) | Op Temp (°C) | Device Marking (4/5) | Samples |
|-------------------|---------------|--------------|-----------------|------|-------------|-----------------|-------------------------|----------------------|--------------|-------------------------|---------|
| LM5035AMH-1/NOPB | LIFEBUY | HTSSOP | PWP | 28 | | TBD | Call TI | Call TI | | LM5035 AMH-1 | |
| LM5035AMH/NOPB | LIFEBUY | HTSSOP | PWP | 20 | | TBD | Call TI | Call TI | -40 to 125 | LM5035 AMH | |
| LM5035AMHX-1/NOPB | LIFEBUY | HTSSOP | PWP | 28 | | TBD | Call TI | Call TI | | LM5035 AMH-1 | |
| LM5035AMHX/NOPB | LIFEBUY | HTSSOP | PWP | 20 | | TBD | Call TI | Call TI | -40 to 125 | LM5035 AMH | |
| LM5035ASQ/NOPB | LIFEBUY | WQFN | NHZ | 24 | | TBD | Call TI | Call TI | -40 to 125 | 5035ASQ | |

(1) The marketing status values are defined as follows:

ACTIVE: Product device recommended for new designs.

LIFEBUY: TI has announced that the device will be discontinued, and a lifetime-buy period is in effect.

NRND: Not recommended for new designs. Device is in production to support existing customers, but TI does not recommend using this part in a new design.

PREVIEW: Device has been announced but is not in production. Samples may or may not be available.

OBSOLETE: TI has discontinued the production of the device.

(2) **RoHS:** TI defines "RoHS" to mean semiconductor products that are compliant with the current EU RoHS requirements for all 10 RoHS substances, including the requirement that RoHS substance do not exceed 0.1% by weight in homogeneous materials. Where designed to be soldered at high temperatures, "RoHS" products are suitable for use in specified lead-free processes. TI may reference these types of products as "Pb-Free".

RoHS Exempt: TI defines "RoHS Exempt" to mean products that contain lead but are compliant with EU RoHS pursuant to a specific EU RoHS exemption.

Green: TI defines "Green" to mean the content of Chlorine (Cl) and Bromine (Br) based flame retardants meet JS709B low halogen requirements of <=1000ppm threshold. Antimony trioxide based flame retardants must also meet the <=1000ppm threshold requirement.

(3) MSL, Peak Temp. - The Moisture Sensitivity Level rating according to the JEDEC industry standard classifications, and peak solder temperature.

(4) There may be additional marking, which relates to the logo, the lot trace code information, or the environmental category on the device.

(5) Multiple Device Markings will be inside parentheses. Only one Device Marking contained in parentheses and separated by a "~" will appear on a device. If a line is indented then it is a continuation of the previous line and the two combined represent the entire Device Marking for that device.

(6) Lead/Ball Finish - Orderable Devices may have multiple material finish options. Finish options are separated by a vertical ruled line. Lead/Ball Finish values may wrap to two lines if the finish value exceeds the maximum column width.

Important Information and Disclaimer: The information provided on this page represents TI's knowledge and belief as of the date that it is provided. TI bases its knowledge and belief on information provided by third parties, and makes no representation or warranty as to the accuracy of such information. Efforts are underway to better integrate information from third parties. TI has taken and continues to take reasonable steps to provide representative and accurate information but may not have conducted destructive testing or chemical analysis on incoming materials and chemicals. TI and TI suppliers consider certain information to be proprietary, and thus CAS numbers and other limited information may not be available for release.

In no event shall TI's liability arising out of such information exceed the total purchase price of the TI part(s) at issue in this document sold by TI to Customer on an annual basis.

NHZ0024B

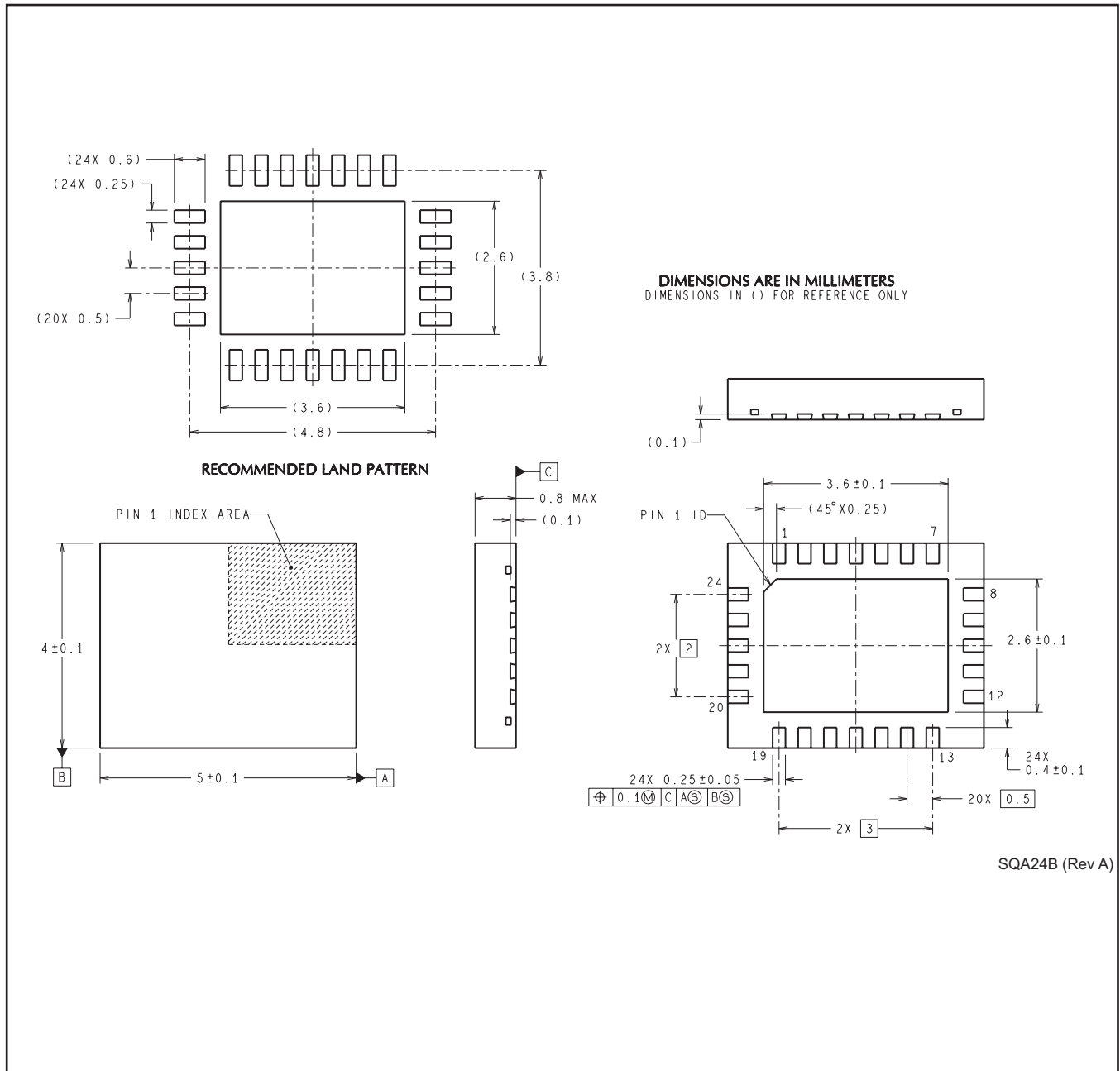

SQA24B (Rev A)

MECHANICAL DATA

PWP (R-PDSO-G20)

PowerPAD™ PLASTIC SMALL OUTLINE

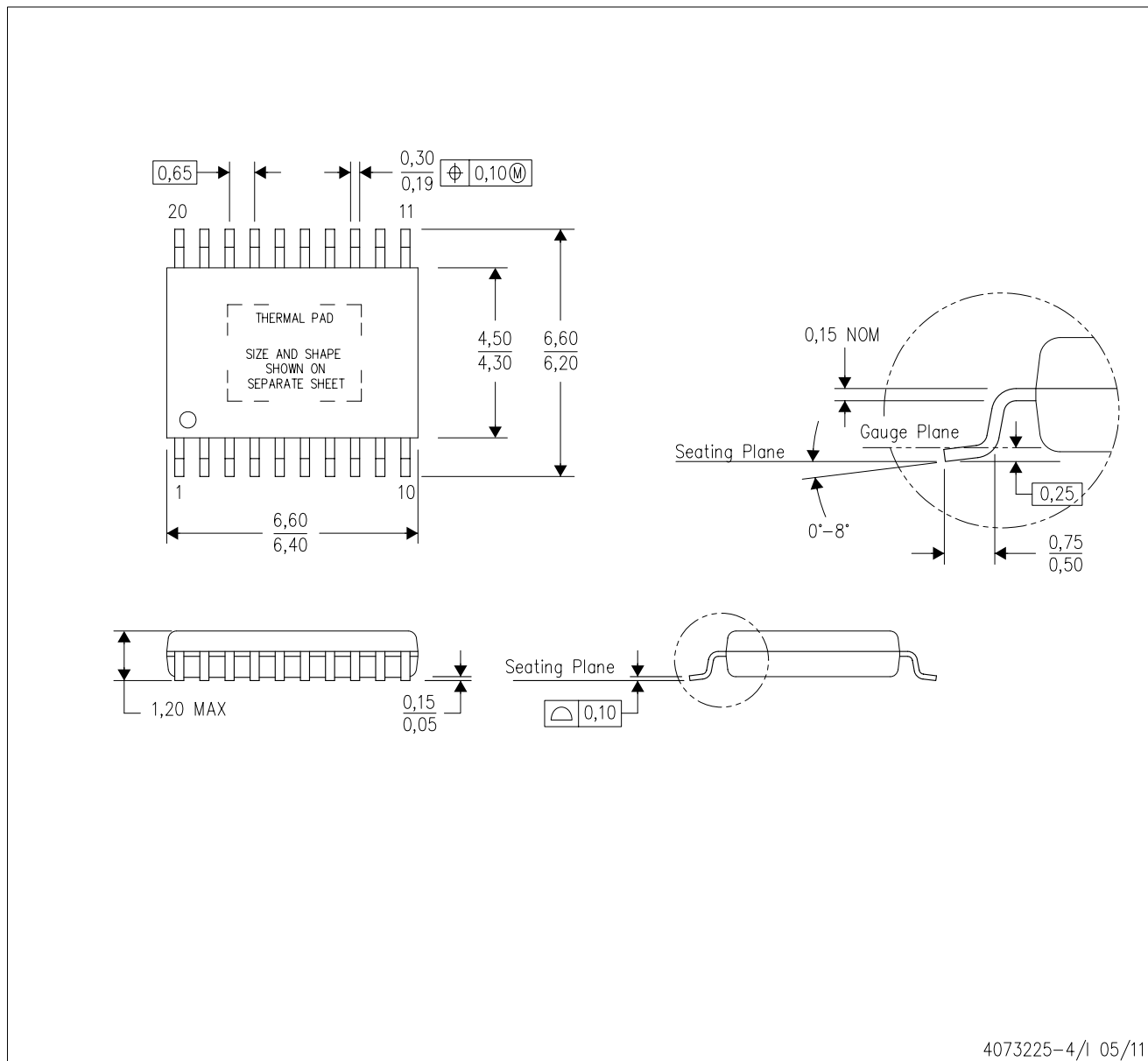

- NOTES:
- All linear dimensions are in millimeters.
 - This drawing is subject to change without notice.
 - Body dimensions do not include mold flash or protrusions. Mold flash and protrusion shall not exceed 0.15 per side.
 - This package is designed to be soldered to a thermal pad on the board. Refer to Technical Brief, PowerPad Thermally Enhanced Package, Texas Instruments Literature No. SLMA002 for information regarding recommended board layout. This document is available at www.ti.com <<http://www.ti.com>>.
 - See the additional figure in the Product Data Sheet for details regarding the exposed thermal pad features and dimensions.
 - Falls within JEDEC MO-153

PowerPAD is a trademark of Texas Instruments.

MECHANICAL DATA

PWP (R-PDSO-G28)

PowerPAD™ PLASTIC SMALL OUTLINE

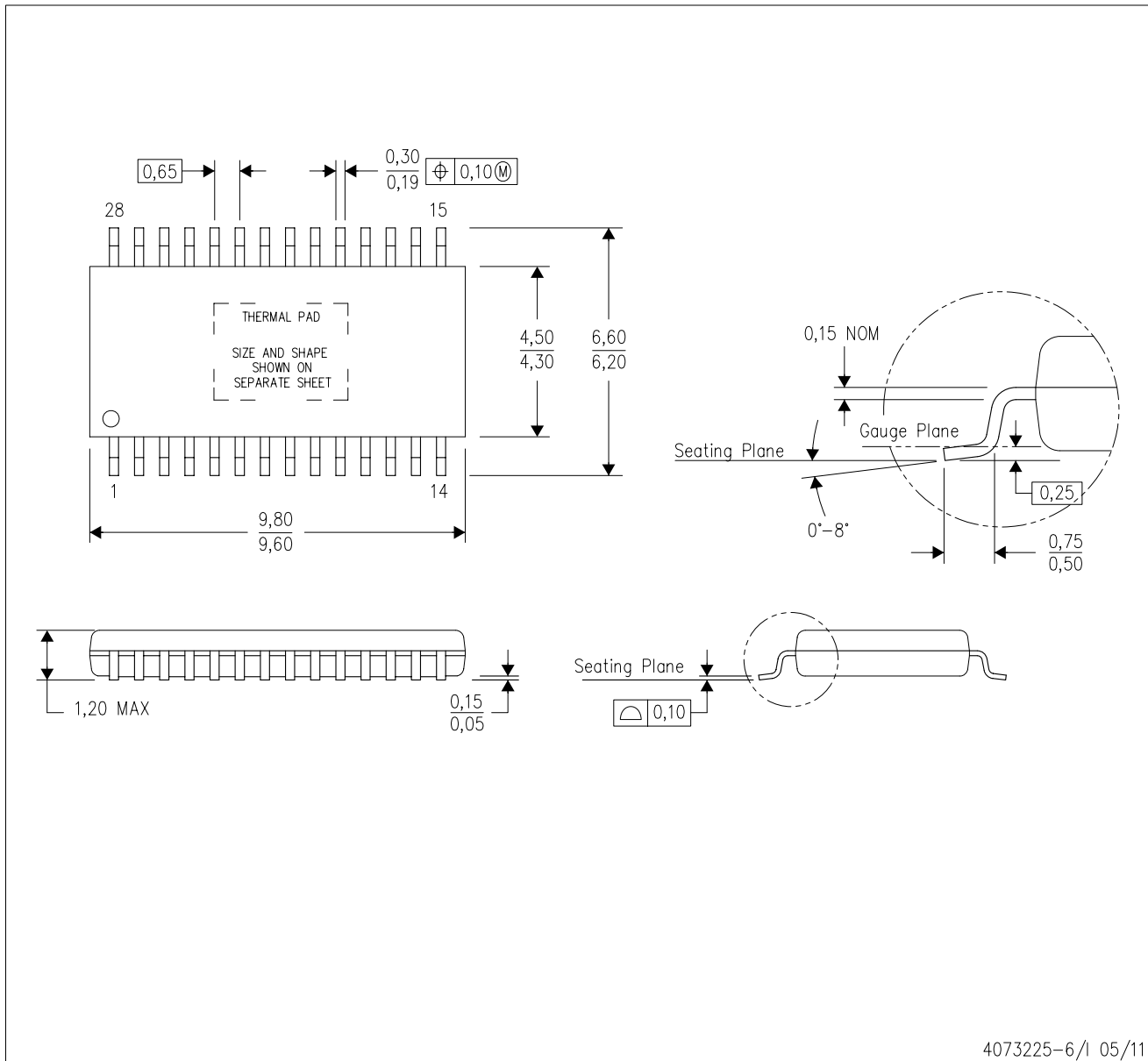

- NOTES:
- All linear dimensions are in millimeters.
 - This drawing is subject to change without notice.
 - Body dimensions do not include mold flash or protrusions. Mold flash and protrusion shall not exceed 0.15 per side.
 - This package is designed to be soldered to a thermal pad on the board. Refer to Technical Brief, PowerPad Thermally Enhanced Package, Texas Instruments Literature No. SLMA002 for information regarding recommended board layout. This document is available at www.ti.com <<http://www.ti.com>>.
 - See the additional figure in the Product Data Sheet for details regarding the exposed thermal pad features and dimensions.
 - Falls within JEDEC MO-153

PowerPAD is a trademark of Texas Instruments.

IMPORTANT NOTICE

Texas Instruments Incorporated (TI) reserves the right to make corrections, enhancements, improvements and other changes to its semiconductor products and services per JESD46, latest issue, and to discontinue any product or service per JESD48, latest issue. Buyers should obtain the latest relevant information before placing orders and should verify that such information is current and complete.

TI's published terms of sale for semiconductor products (<http://www.ti.com/sc/docs/stdterms.htm>) apply to the sale of packaged integrated circuit products that TI has qualified and released to market. Additional terms may apply to the use or sale of other types of TI products and services.

Reproduction of significant portions of TI information in TI data sheets is permissible only if reproduction is without alteration and is accompanied by all associated warranties, conditions, limitations, and notices. TI is not responsible or liable for such reproduced documentation. Information of third parties may be subject to additional restrictions. Resale of TI products or services with statements different from or beyond the parameters stated by TI for that product or service voids all express and any implied warranties for the associated TI product or service and is an unfair and deceptive business practice. TI is not responsible or liable for any such statements.

Buyers and others who are developing systems that incorporate TI products (collectively, "Designers") understand and agree that Designers remain responsible for using their independent analysis, evaluation and judgment in designing their applications and that Designers have full and exclusive responsibility to assure the safety of Designers' applications and compliance of their applications (and of all TI products used in or for Designers' applications) with all applicable regulations, laws and other applicable requirements. Designer represents that, with respect to their applications, Designer has all the necessary expertise to create and implement safeguards that (1) anticipate dangerous consequences of failures, (2) monitor failures and their consequences, and (3) lessen the likelihood of failures that might cause harm and take appropriate actions. Designer agrees that prior to using or distributing any applications that include TI products, Designer will thoroughly test such applications and the functionality of such TI products as used in such applications.

TI's provision of technical, application or other design advice, quality characterization, reliability data or other services or information, including, but not limited to, reference designs and materials relating to evaluation modules, (collectively, "TI Resources") are intended to assist designers who are developing applications that incorporate TI products; by downloading, accessing or using TI Resources in any way, Designer (individually or, if Designer is acting on behalf of a company, Designer's company) agrees to use any particular TI Resource solely for this purpose and subject to the terms of this Notice.

TI's provision of TI Resources does not expand or otherwise alter TI's applicable published warranties or warranty disclaimers for TI products, and no additional obligations or liabilities arise from TI providing such TI Resources. TI reserves the right to make corrections, enhancements, improvements and other changes to its TI Resources. TI has not conducted any testing other than that specifically described in the published documentation for a particular TI Resource.

Designer is authorized to use, copy and modify any individual TI Resource only in connection with the development of applications that include the TI product(s) identified in such TI Resource. NO OTHER LICENSE, EXPRESS OR IMPLIED, BY ESTOPPEL OR OTHERWISE TO ANY OTHER TI INTELLECTUAL PROPERTY RIGHT, AND NO LICENSE TO ANY TECHNOLOGY OR INTELLECTUAL PROPERTY RIGHT OF TI OR ANY THIRD PARTY IS GRANTED HEREIN, including but not limited to any patent right, copyright, mask work right, or other intellectual property right relating to any combination, machine, or process in which TI products or services are used. Information regarding or referencing third-party products or services does not constitute a license to use such products or services, or a warranty or endorsement thereof. Use of TI Resources may require a license from a third party under the patents or other intellectual property of the third party, or a license from TI under the patents or other intellectual property of TI.

TI RESOURCES ARE PROVIDED "AS IS" AND WITH ALL FAULTS. TI DISCLAIMS ALL OTHER WARRANTIES OR REPRESENTATIONS, EXPRESS OR IMPLIED, REGARDING RESOURCES OR USE THEREOF, INCLUDING BUT NOT LIMITED TO ACCURACY OR COMPLETENESS, TITLE, ANY EPIDEMIC FAILURE WARRANTY AND ANY IMPLIED WARRANTIES OF MERCHANTABILITY, FITNESS FOR A PARTICULAR PURPOSE, AND NON-INFRINGEMENT OF ANY THIRD PARTY INTELLECTUAL PROPERTY RIGHTS. TI SHALL NOT BE LIABLE FOR AND SHALL NOT DEFEND OR INDEMNIFY DESIGNER AGAINST ANY CLAIM, INCLUDING BUT NOT LIMITED TO ANY INFRINGEMENT CLAIM THAT RELATES TO OR IS BASED ON ANY COMBINATION OF PRODUCTS EVEN IF DESCRIBED IN TI RESOURCES OR OTHERWISE. IN NO EVENT SHALL TI BE LIABLE FOR ANY ACTUAL, DIRECT, SPECIAL, COLLATERAL, INDIRECT, PUNITIVE, INCIDENTAL, CONSEQUENTIAL OR EXEMPLARY DAMAGES IN CONNECTION WITH OR ARISING OUT OF TI RESOURCES OR USE THEREOF, AND REGARDLESS OF WHETHER TI HAS BEEN ADVISED OF THE POSSIBILITY OF SUCH DAMAGES.

Unless TI has explicitly designated an individual product as meeting the requirements of a particular industry standard (e.g., ISO/TS 16949 and ISO 26262), TI is not responsible for any failure to meet such industry standard requirements.

Where TI specifically promotes products as facilitating functional safety or as compliant with industry functional safety standards, such products are intended to help enable customers to design and create their own applications that meet applicable functional safety standards and requirements. Using products in an application does not by itself establish any safety features in the application. Designers must ensure compliance with safety-related requirements and standards applicable to their applications. Designer may not use any TI products in life-critical medical equipment unless authorized officers of the parties have executed a special contract specifically governing such use. Life-critical medical equipment is medical equipment where failure of such equipment would cause serious bodily injury or death (e.g., life support, pacemakers, defibrillators, heart pumps, neurostimulators, and implantables). Such equipment includes, without limitation, all medical devices identified by the U.S. Food and Drug Administration as Class III devices and equivalent classifications outside the U.S.

TI may expressly designate certain products as completing a particular qualification (e.g., Q100, Military Grade, or Enhanced Product). Designers agree that it has the necessary expertise to select the product with the appropriate qualification designation for their applications and that proper product selection is at Designers' own risk. Designers are solely responsible for compliance with all legal and regulatory requirements in connection with such selection.

Designer will fully indemnify TI and its representatives against any damages, costs, losses, and/or liabilities arising out of Designer's non-compliance with the terms and provisions of this Notice.

Looking for pricing, stock, or lifecycle information?

Click below to explore more details on WIN SOURCE:

 [View LM5035AMHX/NOPB on WIN SOURCE](#)

 [Texas Instruments](#) Information

Optimize Your Supply Chain with WIN SOURCE Solutions

-  Global Sourcing Solution
-  Obsolete Management
-  Cost Control Management
-  Shortage Management
-  Alternative Solution
-  Excess Inventory Management