



THE DATASHEET OF LM5041AMTCX



LM5041A Cascaded PWM Controller

Check for Samples: [LM5041A](#)

FEATURES

- Internal Start-up Bias Regulator
- Programmable Line Under-Voltage Lockout (UVLO) with Adjustable Hysteresis
- Current Mode Control
- Internal Error Amplifier with Reference
- Cycle-by-cycle Over-Current Protection
- Leading Edge Blanking
- Programmable Push-Pull Overlap or Dead Time
- Internal 1.5A Push-Pull Gate Drivers
- Programmable Soft-Start
- Programmable Oscillator with Sync Capability
- Precision Reference
- Thermal Shutdown

APPLICATIONS

- Telecommunication Power Converters
- Industrial Power Converters
- Multi-Output Power Converters
- +42V Automotive Systems

DESCRIPTION

The LM5041A PWM controller contains all of the features necessary to implement either current-fed or voltage-fed push-pull or bridge power converters. These “Cascaded” topologies are well suited for multiple output and higher power applications. The LM5041A’s four control outputs include: the buck stage controls (HD and LD) and the push-pull control outputs (PUSH and PULL). Push-pull outputs are driven at 50% nominal duty cycle at one half of the switching frequency of the buck stage and can be configured for either an overlap time (for current-fed applications) or a both-off time (for voltage-fed applications). Push-pull stage MOSFETs can be driven directly from the internal gate drivers while the buck stage requires an external driver such as the LM5102. The LM5041A includes a high-voltage start-up regulator that operates over a wide input range of 15V to 100V. The PWM controller is designed for high-speed capability including an oscillator frequency range up to 1 MHz and total propagation delays of less than 100ns. Additional features include: line Under-Voltage Lockout (UVLO), soft-start, an error amplifier, precision voltage reference, and thermal shutdown.

The two differences between the LM5041 and the LM5041A are: No second level current limit in the 'A' version No softstart (SS) shutdown comparator in the 'A' version.

PACKAGES

- TSSOP-16
- WSON-16 (5 mm × 5 mm) Thermally Enhanced



Please be aware that an important notice concerning availability, standard warranty, and use in critical applications of Texas Instruments semiconductor products and disclaimers thereto appears at the end of this data sheet.

Typical Application Circuit

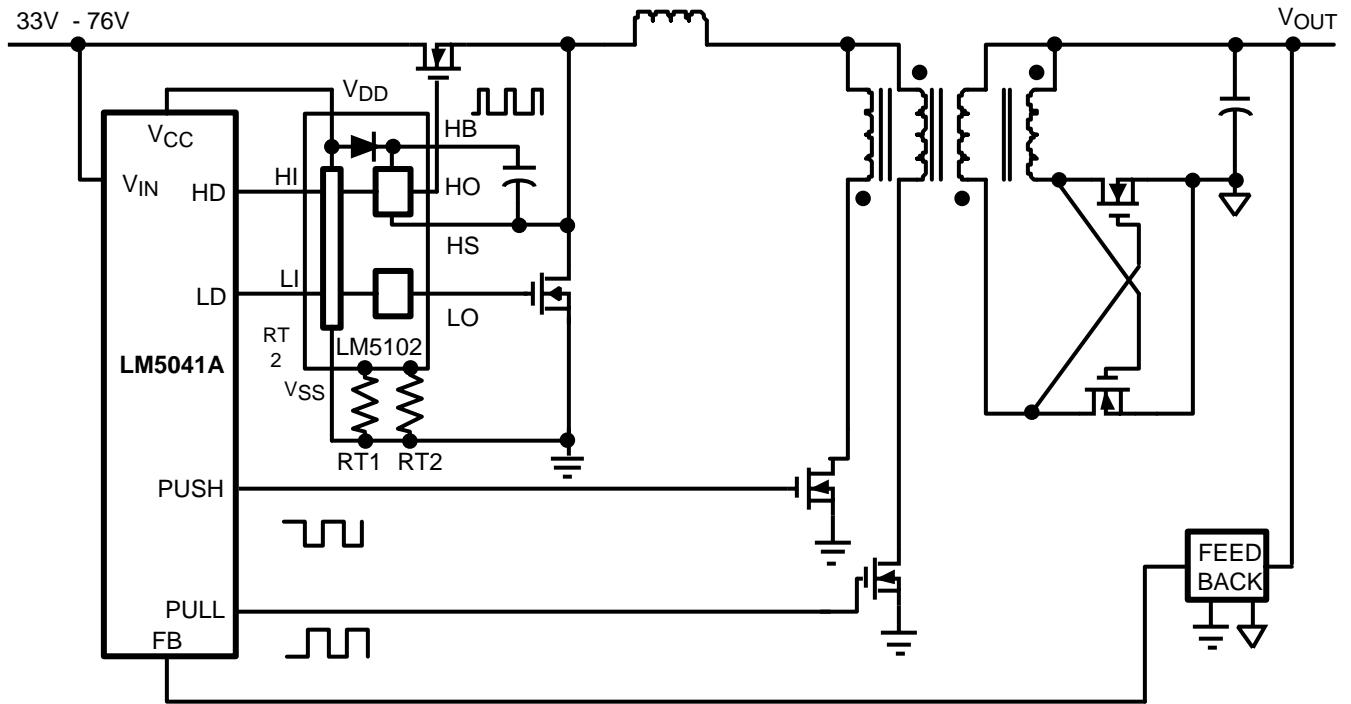

Figure 1. Simplified Cascaded Push-Pull Power Converter

Connection Diagram

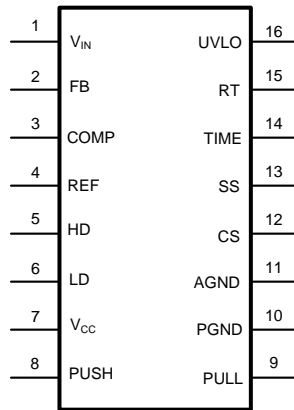

Figure 2. 16-Lead TSSOP or WSON
See PW or NHQ0016A Package

PIN DESCRIPTIONS

PIN	NAME	DESCRIPTION	APPLICATION INFORMATION
1	V _{IN}	Source Input Voltage	Input to start-up regulator. Input range 15V to 100V.
2	FB	Feedback Signal	Inverting input for the internal error amplifier. The non-inverting input is connected to a 0.75V reference.
3	COMP	Output of the Internal Error Amplifier	There is an internal 5kΩ resistor pull-up on this pin. The error amplifier provides an active sink.
4	REF	Precision 5 volt reference output	Maximum output current: 10mA. Locally decouple with a 0.1μF capacitor. Reference stays low until the line UV and the V _{CC} UV are satisfied.
5	HD	Main Buck PWM control output	Buck switch PWM control output. The maximum duty cycle clamp for this output corresponds to an off time of typically 240ns per cycle. The LM5101 or LM5102 Buck stage gate driver can be used to level shift and drive the Buck switch.
6	LD	Sync Switch control output	Sync Switch control output. Inversion of HD output. The LM5101 or LM5102 lower drive can be used to drive the synchronous rectifier switch.
7	V _{CC}	Output from the internal high voltage start-up regulator. Regulated to 9 volts.	If an auxiliary winding raises the voltage on this pin above the regulation setpoint, the internal start-up regulator will shutdown, reducing the IC power dissipation.
8	PUSH	Output of the push-pull drivers	Output of the push-pull gate driver. Output capability of 1.5A peak .
9	PULL	Output of the push-pull drivers	Output of the push-pull gate driver. Output capability of 1.5A peak.
10	PGND	Power ground	Connect directly to analog ground.
11	AGND	Analog ground	Connect directly to power ground.
12	CS	Current sense input	Current sense input to the PWM comparator (CM control). There is a 50ns leading edge blanking on this pin. Using separate dedicated comparator, if CS exceeds 0.5V the outputs will go into cycle by cycle current limit.
13	SS	Soft-start control	An external capacitor and an internal 10uA current source, set the soft-start ramp.
14	TIME	Push-Pull overlap and dead time control	An external resistor (R _{SET}) sets the overlap time or dead time for the push-pull outputs. A resistor connected between TIME and GND produces overlap. A resistor connected between TIME and REF produces dead time.
15	RT / SYNC	Oscillator timing resistor pin and sync	An external resistor sets the oscillator frequency. This pin will also accept an external oscillator.
16	UVLO	Line Under-Voltage Shutdown	An external divider from the power converter source sets the shutdown levels. Threshold of operation equals 2.5V. Hysteresis is set by a switched internal current source (20μA).
WSN DAP	SUB	Die substrate	The exposed die attach pad on the WSON package should be connected to a PCB thermal pad at ground potential. For additional information on using the No Pull Back WSON package, please refer to LLP Application Note AN-1187 (SNOA401).

Block Diagram

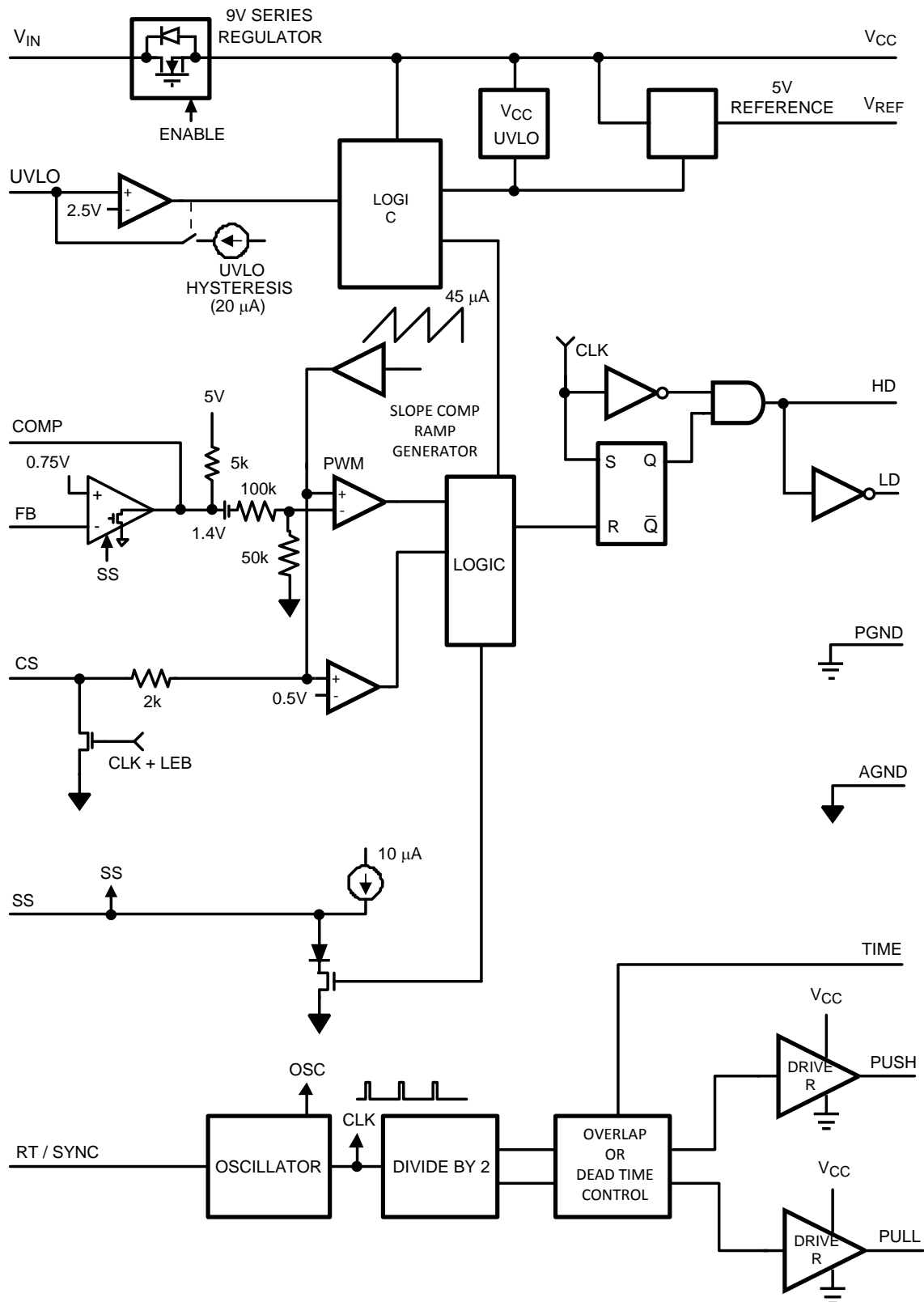

Figure 3. Simplified Block Diagram



These devices have limited built-in ESD protection. The leads should be shorted together or the device placed in conductive foam during storage or handling to prevent electrostatic damage to the MOS gates.

Absolute Maximum Ratings⁽¹⁾⁽²⁾

V _{IN} to GND		100V	
V _{CC} to GND		16V	
All Other Inputs to GND		-0.3 to 7V	
Junction Temperature		150°C	
Storage Temperature Range		-65°C to +150°C	
ESD Rating		2 kV	
Lead Temperature ⁽³⁾	Wave	4 seconds	260°C
	Infrared	10 seconds	240°C
	Vapor Phase	75 seconds	219°C

- (1) Absolute Maximum Ratings are limits beyond which damage to the device may occur. Operating Ratings are conditions under which operation of the device is intended to be functional. For specifications and test conditions, see the [Electrical Characteristics](#).
- (2) If Military/Aerospace specified devices are required, please contact the Texas Instruments Sales Office/Distributors for availability and specifications.
- (3) For detailed information on soldering plastic TSSOP and WSON packages, visit www.ti.com/packaging.

Operating Ratings⁽¹⁾

V _{IN}	15 to 90V
Junction Temperature	-40°C to +125°C

- (1) Absolute Maximum Ratings are limits beyond which damage to the device may occur. Operating Ratings are conditions under which operation of the device is intended to be functional. For specifications and test conditions, see the [Electrical Characteristics](#).

Electrical Characteristics

Specifications with standard typeface are for T_J = 25°C, and those with **boldface** type apply over full **Operating Junction Temperature range**. V_{IN} = 48V, V_{CC} = 10V, R_T = 26.7kΩ, R_{SET} = 20kΩ unless otherwise stated⁽¹⁾

Symbol	Parameter	Conditions	Min	Typ	Max	Units
Startup Regulator						
V _{CC} Reg	V _{CC} Regulation	open circuit	8.7	9	9.3	V
	V _{CC} Current Limit	See ⁽²⁾	15	25		mA
I-V _{IN}	Startup Regulator Leakage (external V _{CC} Supply)	V _{IN} = 100V		145	500	μA
	Shutdown Current (I _{in})	UVLO = 0V, V _{CC} = open		350	450	μA
V_{CC} Supply						
	V _{CC} Under-voltage Lockout Voltage (positive going V _{CC})		V_{CC} Reg - 400mV	V _{CC} Reg - 275mV		V
	V _{CC} Under-voltage Hysteresis		1.7	2.1	2.6	V
	Supply Current (I _{CC})	C _L = 0		3	4	mA
Error Amplifier						
GBW	Gain Bandwidth			3		MHz
	DC Gain			80		dB
	Input Voltage	V _{FB} = COMP	0.735	0.75	0.765	V
	COMP Sink Capability	V _{FB} = 1.5V, COMP = 1V	4	8		mA

- (1) All electrical characteristics having room temperature limits are tested during production with T_A = T_J = 25°C. All hot and cold limits are specified by correlating the electrical characteristics to process and temperature variations and applying statistical process control.
- (2) Device thermal limitations may limit usable range.

Electrical Characteristics (continued)

Specifications with standard typeface are for $T_J = 25^\circ\text{C}$, and those with **boldface** type apply over full **Operating Junction Temperature range**. $V_{IN} = 48\text{V}$, $V_{CC} = 10\text{V}$, $R_T = 26.7\text{k}\Omega$, $R_{SET} = 20\text{k}\Omega$ unless otherwise stated⁽¹⁾

Symbol	Parameter	Conditions	Min	Typ	Max	Units
Reference Supply						
V_{REF}	Ref Voltage	$I_{REF} = 0\text{ mA}$	4.85	5	5.15	V
	Ref Voltage Regulation	$I_{REF} = 0\text{ to }10\text{mA}$		25	50	mV
	Ref Current Limit		15	20		mA
Current Limit						
	ILIM Delay to Output	CS Step from 0 to 0.6V Time to Onset of OUT Transition (90%), $C_L = 0$		40		ns
	Cycle by Cycle Threshold Voltage		0.45	0.5	0.55	V
	Leading Edge Blanking Time			50		ns
	CS Sink Current (clocked)	CS = 0.3V	2	5		mA
Soft-Start						
	Soft-start Current Source		7	10	13	μA
	Soft-start to COMP Offset		0.35	0.55	0.75	V
Oscillator						
	Frequency1 ($R_T = 26.7\text{k}\Omega$)	$T_J = 25^\circ\text{C}$	180 175	200	220 225	kHz
	Frequency2 ($R_T = 7.87\text{k}\Omega$)		515	600	685	kHz
	Sync threshold			3	3.5	V
PWM Comparator						
	Delay to Output	COMP set to 2V CS stepped 0 to 0.4V, Time to onset of OUT transition low		25		ns
	Max Duty Cycle	TS = Oscillator Period		($T_s - 240\text{ns}$)/ T_s		%
	Min Duty Cycle	COMP = 0V			0	%
	COMP to PWM Comparator Gain			0.32		
	COMP Open Circuit Voltage	FB = 0V	4.1	4.8	5.5	V
	COMP Short Circuit Current	FB = 0V, COMP = 0V	0.6	1	1.4	mA
Slope Compensation						
	Slope Comp Amplitude	Delta increase at PWM Comparator to CS		110		mV
UVLO Shutdown						
	Under-voltage Shutdown		2.44	2.5	2.56	V
	Under-voltage Shutdown Hysteresis Current Source		16	20	24	μA

Electrical Characteristics (continued)

Specifications with standard typeface are for $T_J = 25^\circ\text{C}$, and those with **boldface** type apply over full **Operating Junction Temperature range**. $V_{IN} = 48\text{V}$, $V_{CC} = 10\text{V}$, $R_T = 26.7\text{k}\Omega$, $R_{SET} = 20\text{k}\Omega$ unless otherwise stated⁽¹⁾

Symbol	Parameter	Conditions	Min	Typ	Max	Units
Buck Stage Outputs						
	Output High level			5 (V_{REF})		V
	Output High Saturation	$I_{OUT} = 10\text{mA}$, $REF = V_{OUT}$		0.5	1	V
	Output Low Saturation	$I_{OUT} = -10\text{mA}$		0.5	1	V
	Rise Time	$C_L = 100\text{pF}$		10		ns
	Fall Time	$C_L = 100\text{pF}$		10		ns
Push-Pull Outputs						
	Overlap Time	$R_{SET} = 20\text{k}\Omega$ Connected to GND, 50% to 50% Transitions	60	90	120	ns
	Dead Time	$R_{SET} = 20\text{k}\Omega$ Connected to REF, 50% to 50% Transitions	65	95	125	ns
	Output High Saturation	$I_{OUT} = 50\text{mA}$, $V_{CC} - V_{OUT}$		0.25	0.5	V
	Output Low Saturation	$I_{OUT} = 100\text{mA}$		0.5	1	V
	Rise Time	$C_L = 1\text{nF}$		20		ns
	Fall Time	$C_L = 1\text{nF}$		20		ns
Thermal Shutdown						
T_{SD}	Thermal Shutdown Temp.			165		$^\circ\text{C}$
	Thermal Shutdown Hysteresis			25		$^\circ\text{C}$
Thermal Resistance						
θ_{JA}	Junction to Ambient	TSSOP Package		125		$^\circ\text{C/W}$
		WSON Package		32		$^\circ\text{C/W}$

Typical Performance Characteristics

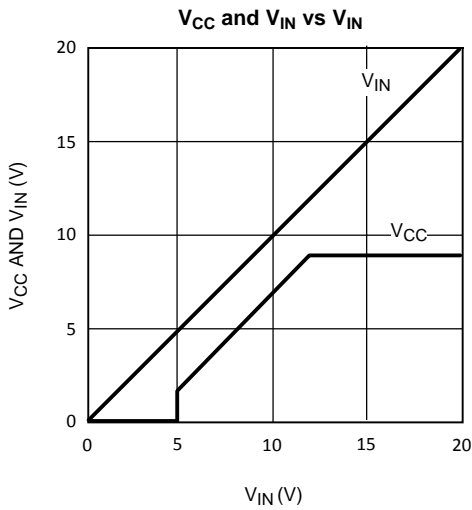

Figure 4.

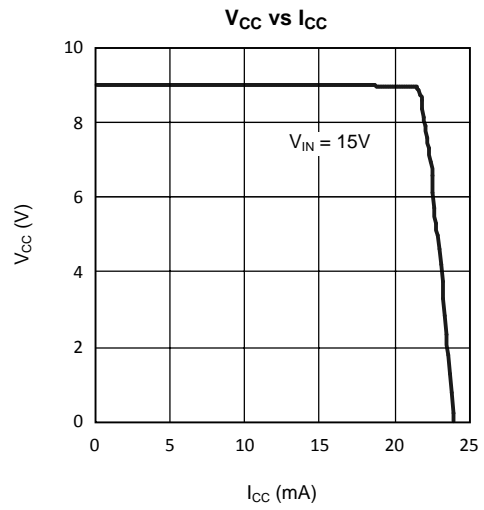

Figure 5.

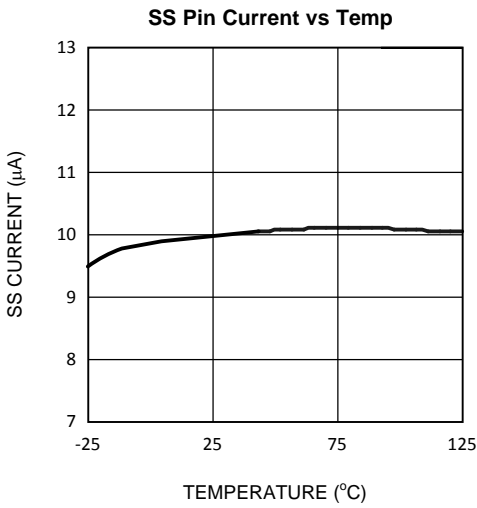

Figure 6.

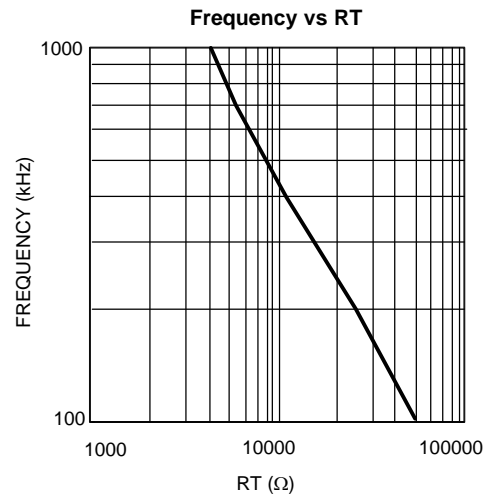

Figure 7.

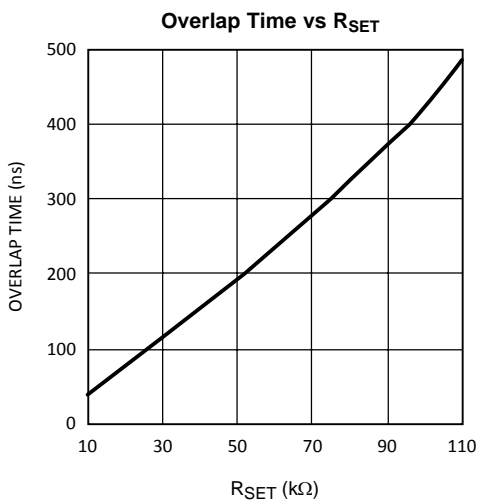

Figure 8.

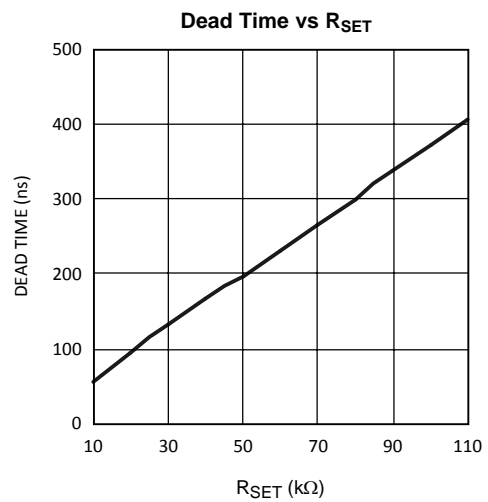

Figure 9.

Typical Performance Characteristics (continued)

Overlap Time vs Temp

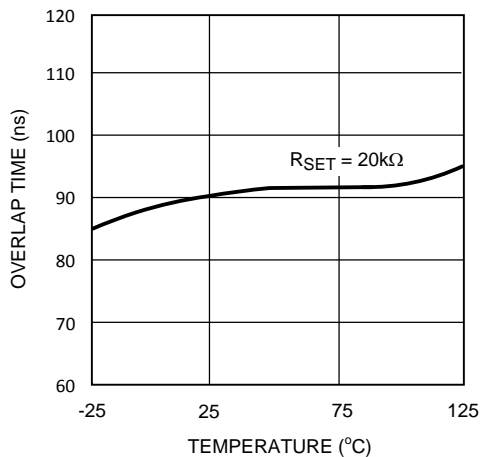

Figure 10.

Dead Time vs Temp

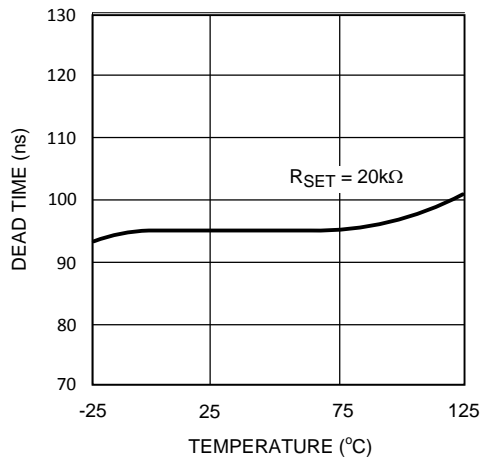

Figure 11.

Error Amplifier Gain Phase

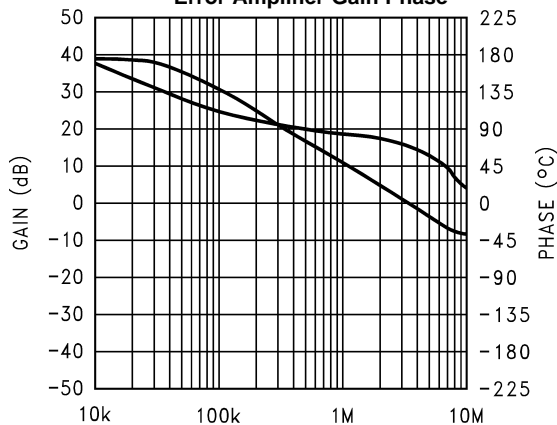

Figure 12.

DETAILED OPERATING DESCRIPTION

The LM5041A PWM controller contains all of the features necessary to implement either current-fed or voltage-fed push-pull or bridge power converters. These “Cascaded” topologies are well suited for multiple output and higher power applications. The LM5041A’s four control outputs include: the buck stage controls (HD and LD) and the push-pull control outputs (PUSH and PULL). Push-pull outputs are driven at 50% nominal duty cycle at one half of the switching frequency of the buck stage and can be configured for either an overlap time (for current-fed applications) or a both-off time (for voltage-fed applications). Push-pull stage MOSFETs can be driven directly from the internal gate drivers while the buck stage requires an external driver such as the LM5102. The LM5041A includes a high-voltage start-up regulator that operates over a wide input range of 15V to 100V. The PWM controller is designed for high-speed capability including an oscillator frequency range up to 1 MHz and total propagation delays of less than 100ns. Additional features include: line Under-Voltage Lockout (UVLO), soft-start, an error amplifier, precision voltage reference, and thermal shutdown.

High Voltage Start-Up Regulator

The LM5041A contains an internal high-voltage start-up regulator, thus the input pin (V_{IN}) can be connected directly to the line voltage. The regulator output is internally current limited to 15mA. When power is applied, the regulator is enabled and sources current into an external capacitor connected to the V_{CC} pin. The recommended capacitance range for the V_{CC} regulator is 0.1 μ F to 100 μ F. When the voltage on the V_{CC} pin reaches the regulation point of 9V and the internal voltage reference (REF) reaches its regulation point of 5V, the controller outputs are enabled. The Buck stage outputs will remain enabled until V_{CC} falls below 7V or the line Under-Voltage Lockout detector indicates that V_{IN} is out of range. The push-pull outputs continue switching until the REF pin voltage falls below approximately 3V. In typical applications, an auxiliary transformer winding is connected through a diode to the V_{CC} pin. This winding must raise the V_{CC} voltage above 9.3V to shut off the internal start-up regulator. Powering V_{CC} from an auxiliary winding improves efficiency while reducing the controller’s power dissipation. The recommended capacitance range for the V_{ref} regulator output is 0.1 μ F to 10 μ F.

The external V_{CC} capacitor must be sized such that the capacitor maintains a V_{CC} voltage greater than 7V during the initial start-up. During a fault mode when the converter auxiliary winding is inactive, external current draw on the V_{CC} line should be limited so the power dissipated in the start-up regulator does not exceed the maximum power dissipation of the controller.

An external start-up or other bias rail can be used instead of the internal start-up regulator by connecting the V_{CC} and the V_{IN} pins together and feeding the external bias voltage into the two pins.

Line Under-Voltage Detector

The LM5041A contains a line Under-Voltage Lockout (UVLO) circuit. An external set-point resistor divider from V_{IN} to ground sets the operational range of the converter. The divider must be designed such that the voltage at the UVLO pin will be greater than 2.5V when V_{IN} is in the desired operating range. If the Under-Voltage threshold is not met, all functions of the controller are disabled and the controller will enter a low-power state with input current <300 μ A. UVLO hysteresis is accomplished with an internal 20 μ A current source that is switched on or off into the impedance of the set-point divider. When the UVLO threshold is exceeded, the current source is activated to instantly raise the voltage at the UVLO pin. When the UVLO pin falls below the 2.5V threshold, the current source is turned off causing the voltage at the UVLO pin to fall. The UVLO pin can also be used to implement a remote enable / disable function. By shorting the UVLO pin to ground, the converter can be disabled.

Buck Stage Control Outputs

The LM5041A Buck switch maximum duty cycle clamp ensures that there will be sufficient off time each cycle to recharge the bootstrap capacitor used in the high side gate driver. The Buck switch remains off, and the sync switch remains on, for at least 250ns per switching cycle. The Buck stage control outputs (LD and HD) are CMOS buffers with logic levels of 0 to 5V.

During any fault state or Under-Voltage off state, the buck stage control outputs will default to HD low and LD high.

Push-Pull Outputs

The push pull outputs operate continuously at a nominal 50% duty cycle. A distinguishing feature of the LM5041A is the ability to accurately configure either dead time (both-off) or overlap time (both-on) on the complementary push-pull outputs. The overlap/dead time magnitude is controlled by a resistor connected to the TIME pin on the controller. The TIME pin holds one end of the resistor at 2.5V and the other end of the resistor should be connected to either REF for dead time control setting or to GND for overlap control. The polarity of the current in the TIME is detected by the LM5041A. The magnitude of the overlap/dead time can be calculated as follows:

$$\text{Overlap Time (ns)} = (3.66 \times R_{\text{SET}}) + 7$$

Overlap Time in ns, R_{SET} connected to GND, R_{SET} in $k\Omega$

$$\text{Dead Time (ns)} = (3.69 \times R_{\text{SET}}) + 21$$

Dead Time in ns, R_{SET} connected to REF, R_{SET} in $k\Omega$

Recommended R_{SET} programming range: 10k Ω to 100k Ω

Current-fed designs require a period of overlap to insure there is a continuous path for the buck inductor current. Voltage-fed designs require a period of dead time to insure there is no time when the push-pull transformer acts as a shorted turn to the low impedance sourcing node. The push-pull outputs alternate continuously under all conditions provided REF the voltage is greater than 3V.

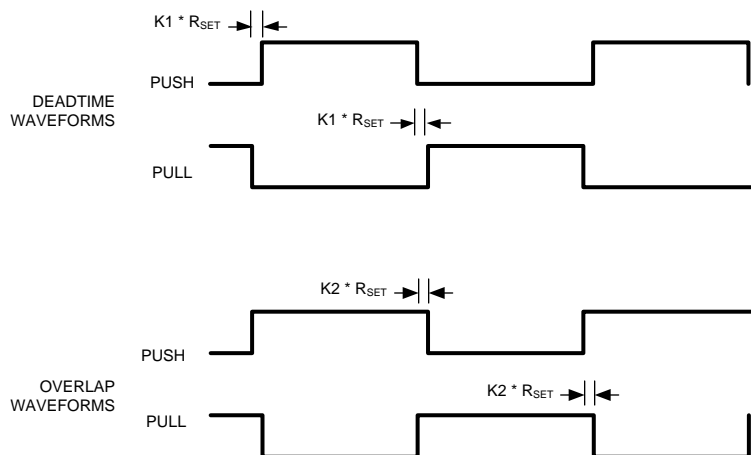

Figure 13.

PWM Comparator

The PWM comparator compares the slope compensated current ramp signal to the loop error voltage from the internal error amplifier (COMP pin). This comparator is optimized for speed in order to achieve minimum controllable duty cycles. The comparator polarity is such that 0V on the COMP pin will produce zero duty cycle in the buck stage.

Error Amplifier

An internal high gain wide-bandwidth error amplifier is provided within the LM5041A. The amplifier's non-inverting input is tied to a 0.75V reference. The inverting input is connected to the FB pin. In non-isolated applications the power converter output is connected to the FB pin via the voltage setting resistors. Loop compensation components are connected between the COMP and FB pins. For most isolated applications the error amplifier function is implemented on the secondary side of the converter and the internal error amp is not used. The internal error amplifier is configured as an open drain output and can be disabled by connecting the FB pin to ground. An internal 5k Ω pull-up resistor between the 5V reference and COMP can be used as the pull-up for an opto-coupler in isolated applications.

Current Limit/Current Sense

The LM5041A provides cycle-by-cycle over-current protection. If the voltage at the CS comparator (CS pin voltage plus slope comp voltage) exceeds 0.5V the present buck stage duty cycle is terminated (cycle by cycle current limit). A small RC filter located near the controller is recommended to filter current sense signals at the CS pin. An internal MOSFET discharges the external CS pin for an additional 50ns at the beginning of each cycle to reduce the leading edge spike that occurs when the buck stage MOSFET is turned on.

The LM5041A current sense and PWM comparators are very fast, and may respond to short duration noise pulses. Layout considerations are critical for the current sense filter and sense resistor. The capacitor associated with the CS filter must be placed close to the device and connected directly to the pins of the controller (CS and GND). If a current sense transformer is used, both leads of the transformer secondary should be routed to the sense resistor, which should also be located close to the IC. A resistor may be used for current sensing instead of a transformer, located in the push-pull transistor sources, but a low inductance type of resistor is required. When designing with a sense resistor, all of the noise sensitive low power grounds should be connected together around the IC and a single connection should be made to the high current power ground (sense resistor ground point).

Oscillator and Sync Capability

The LM5041A oscillator is set by a single external resistor connected between the RT pin and GND. To set a desired oscillator frequency (F), the necessary RT resistor can be calculated from:

$$RT = \frac{(1/F) - 235 \times 10^{-9}}{182 \times 10^{-12}} \Omega \quad (1)$$

The buck stage will switch at the oscillator frequency and each push-pull output will switch at half the oscillator frequency in a push-pull configuration. The LM5041A can also be synchronized to an external clock. The external clock must have a higher frequency than the free running frequency set by the RT resistor. The clock signal should be capacitively coupled into the RT pin with a 100pF capacitor. A peak voltage level greater than 3V is required for detection of the sync pulse. The sync pulse width should be set in the 15 to 150ns range by the external components. The RT resistor is always required, whether the oscillator is free running or externally synchronized. The voltage at the RT pin is internally regulated to 2V. The RT resistor should be located very close to the device and connected directly to the pins of the IC (RT and GND).

Slope Compensation

The PWM comparator compares the current sense signal to the voltage at the COMP pin. The output stage of the internal error amplifier generally drives the COMP pin. At duty cycles greater than 50 percent, current mode control circuits are subject to sub-harmonic oscillation. By adding an additional fixed ramp signal (slope compensation) to the current sense ramp, oscillations can be avoided. The LM5041A integrates this slope compensation by buffering the internal oscillator ramp and summing a current ramp generated by the oscillator internally with the current sense signal. Additional slope compensation may be provided by increasing the source impedance of the current sense signal.

Soft-start and Shutdown

The soft-start feature allows the power converter to gradually reach the initial steady state operating point, thereby reducing start-up stresses and surges. At power on, a 10uA current is sourced out of the soft-start pin (SS) to charge an external capacitor. The capacitor voltage will ramp up slowly and will limit the maximum duty cycle of the buck stage. In the event of a fault as indicated by V_{CC} Under-voltage, line Under-voltage the output drivers are disabled and the soft-start capacitor is discharged to 0.7V. When the fault condition is no longer present, a soft-start sequence will begin again and buck stage duty cycle will gradually increase as the soft-start capacitor is charged.

Thermal Protection

Internal Thermal Shutdown circuitry is provided to protect the integrated circuit in the event that the maximum junction temperature is exceeded. When activated, typically at 165 degrees Celsius, the controller is forced into a low-power standby state, disabling the output drivers and the bias regulator. This feature is provided to prevent catastrophic failures from accidental device overheating.

Application Circuit: Input 35-80V, Output 2.5V, 50A

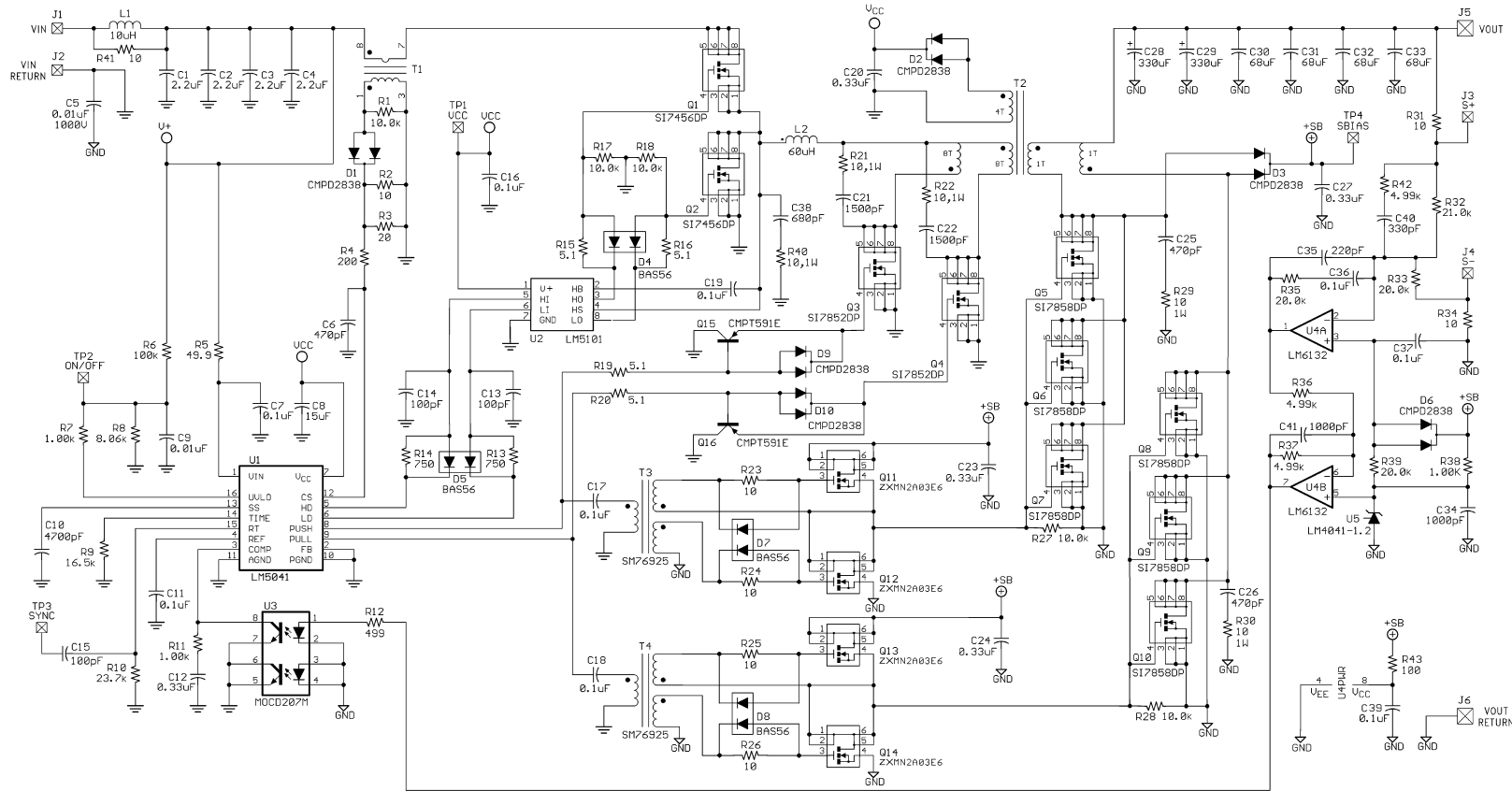

REVISION HISTORY

Changes from Revision A (March 2013) to Revision B	Page
• Changed layout of National Data Sheet to TI format	14

PACKAGING INFORMATION

Orderable Device	Status (1)	Package Type	Package Drawing	Pins	Package Qty	Eco Plan (2)	Lead/Ball Finish (6)	MSL Peak Temp (3)	Op Temp (°C)	Device Marking (4/5)	Samples
LM5041AMTC/NOPB	ACTIVE	TSSOP	PW	16	92	Green (RoHS & no Sb/Br)	CU SN	Level-1-260C-UNLIM	-40 to 125	LM5041A MTC	Samples
LM5041AMTCX/NOPB	ACTIVE	TSSOP	PW	16	2500	Green (RoHS & no Sb/Br)	CU SN	Level-1-260C-UNLIM	-40 to 125	LM5041A MTC	Samples
LM5041ASD/NOPB	ACTIVE	WSON	NHQ	16	1000	Green (RoHS & no Sb/Br)	CU SN	Level-1-260C-UNLIM	-40 to 125	5041ASD	Samples

(1) The marketing status values are defined as follows:

ACTIVE: Product device recommended for new designs.

LIFEBUY: TI has announced that the device will be discontinued, and a lifetime-buy period is in effect.

NRND: Not recommended for new designs. Device is in production to support existing customers, but TI does not recommend using this part in a new design.

PREVIEW: Device has been announced but is not in production. Samples may or may not be available.

OBsolete: TI has discontinued the production of the device.

(2) Eco Plan - The planned eco-friendly classification: Pb-Free (RoHS), Pb-Free (RoHS Exempt), or Green (RoHS & no Sb/Br) - please check <http://www.ti.com/productcontent> for the latest availability information and additional product content details.

TBD: The Pb-Free/Green conversion plan has not been defined.

Pb-Free (RoHS): TI's terms "Lead-Free" or "Pb-Free" mean semiconductor products that are compatible with the current RoHS requirements for all 6 substances, including the requirement that lead not exceed 0.1% by weight in homogeneous materials. Where designed to be soldered at high temperatures, TI Pb-Free products are suitable for use in specified lead-free processes.

Pb-Free (RoHS Exempt): This component has a RoHS exemption for either 1) lead-based flip-chip solder bumps used between the die and package, or 2) lead-based die adhesive used between the die and leadframe. The component is otherwise considered Pb-Free (RoHS compatible) as defined above.

Green (RoHS & no Sb/Br): TI defines "Green" to mean Pb-Free (RoHS compatible), and free of Bromine (Br) and Antimony (Sb) based flame retardants (Br or Sb do not exceed 0.1% by weight in homogeneous material)

(3) MSL, Peak Temp. - The Moisture Sensitivity Level rating according to the JEDEC industry standard classifications, and peak solder temperature.

(4) There may be additional marking, which relates to the logo, the lot trace code information, or the environmental category on the device.

(5) Multiple Device Markings will be inside parentheses. Only one Device Marking contained in parentheses and separated by a "~" will appear on a device. If a line is indented then it is a continuation of the previous line and the two combined represent the entire Device Marking for that device.

(6) Lead/Ball Finish - Orderable Devices may have multiple material finish options. Finish options are separated by a vertical ruled line. Lead/Ball Finish values may wrap to two lines if the finish value exceeds the maximum column width.

Important Information and Disclaimer: The information provided on this page represents TI's knowledge and belief as of the date that it is provided. TI bases its knowledge and belief on information provided by third parties, and makes no representation or warranty as to the accuracy of such information. Efforts are underway to better integrate information from third parties. TI has taken and

continues to take reasonable steps to provide representative and accurate information but may not have conducted destructive testing or chemical analysis on incoming materials and chemicals. TI and TI suppliers consider certain information to be proprietary, and thus CAS numbers and other limited information may not be available for release.

In no event shall TI's liability arising out of such information exceed the total purchase price of the TI part(s) at issue in this document sold by TI to Customer on an annual basis.

TAPE AND REEL INFORMATION

QUADRANT ASSIGNMENTS FOR PIN 1 ORIENTATION IN TAPE

*All dimensions are nominal

Device	Package Type	Package Drawing	Pins	SPQ	Reel Diameter (mm)	Reel Width W1 (mm)	A0 (mm)	B0 (mm)	K0 (mm)	P1 (mm)	W (mm)	Pin1 Quadrant
LM5041AMTCX/NOPB	TSSOP	PW	16	2500	330.0	12.4	6.95	5.6	1.6	8.0	12.0	Q1
LM5041ASD/NOPB	WSO	NHQ	16	1000	178.0	12.4	5.3	5.3	1.3	8.0	12.0	Q1

TAPE AND REEL BOX DIMENSIONS

*All dimensions are nominal

Device	Package Type	Package Drawing	Pins	SPQ	Length (mm)	Width (mm)	Height (mm)
LM5041AMTCX/NOPB	TSSOP	PW	16	2500	367.0	367.0	35.0
LM5041ASD/NOPB	WSON	NHQ	16	1000	210.0	185.0	35.0

NHQ0016A

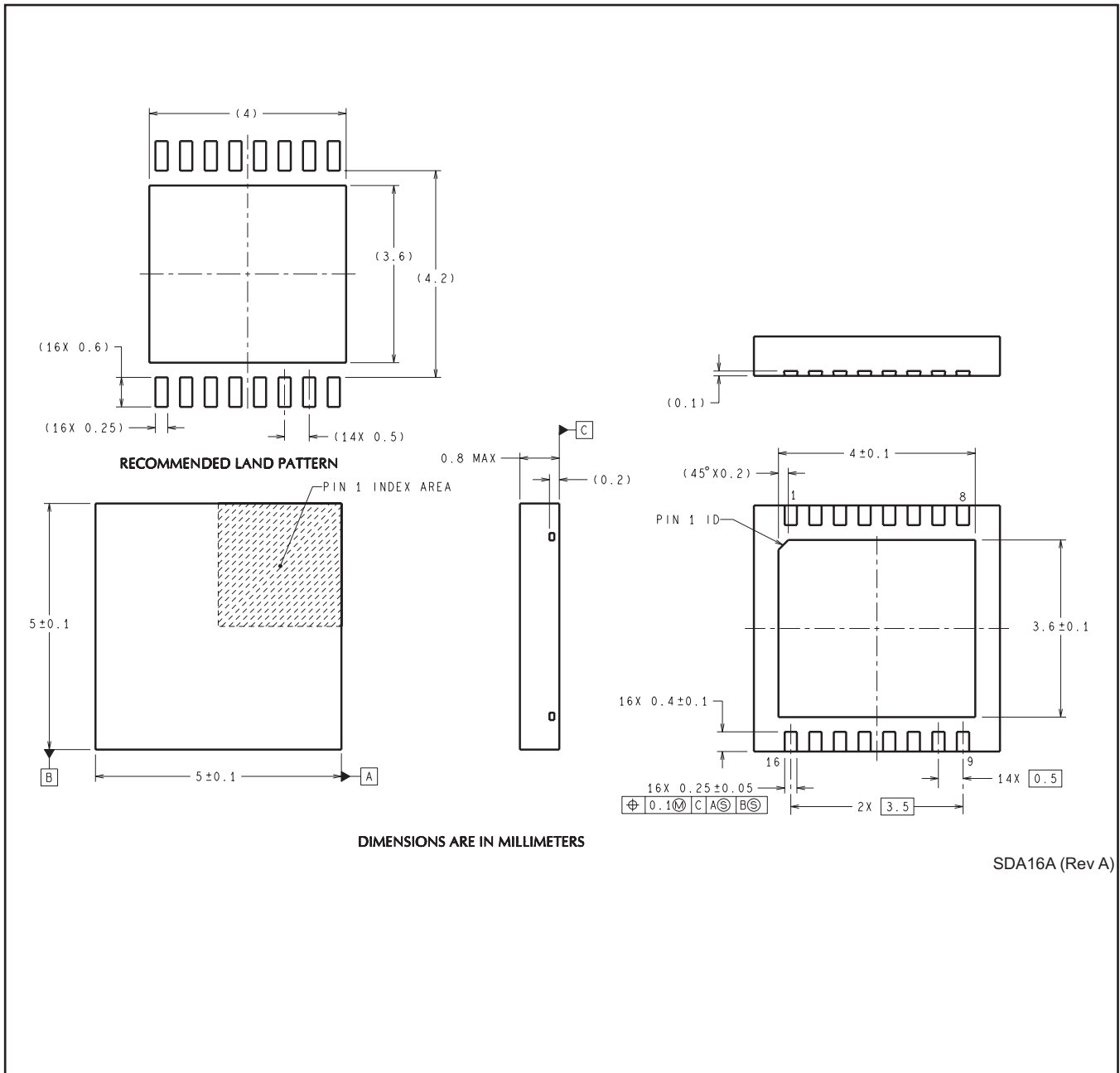



4220204/A 02/2017

NOTES:

1. All linear dimensions are in millimeters. Any dimensions in parenthesis are for reference only. Dimensioning and tolerancing per ASME Y14.5M.
2. This drawing is subject to change without notice.
3. This dimension does not include mold flash, protrusions, or gate burrs. Mold flash, protrusions, or gate burrs shall not exceed 0.15 mm per side.
4. This dimension does not include interlead flash. Interlead flash shall not exceed 0.25 mm per side.
5. Reference JEDEC registration MO-153.

EXAMPLE BOARD LAYOUT

PW0016A

TSSOP - 1.2 mm max height

SMALL OUTLINE PACKAGE



LAND PATTERN EXAMPLE
EXPOSED METAL SHOWN
SCALE: 10X



SOLDER MASK DETAILS

4220204/A 02/2017

NOTES: (continued)

- 6. Publication IPC-7351 may have alternate designs.
- 7. Solder mask tolerances between and around signal pads can vary based on board fabrication site.

EXAMPLE STENCIL DESIGN

PW0016A

TSSOP - 1.2 mm max height

SMALL OUTLINE PACKAGE



SOLDER PASTE EXAMPLE
BASED ON 0.125 mm THICK STENCIL
SCALE: 10X

4220204/A 02/2017

NOTES: (continued)

8. Laser cutting apertures with trapezoidal walls and rounded corners may offer better paste release. IPC-7525 may have alternate design recommendations.
9. Board assembly site may have different recommendations for stencil design.

IMPORTANT NOTICE AND DISCLAIMER

TI PROVIDES TECHNICAL AND RELIABILITY DATA (INCLUDING DATASHEETS), DESIGN RESOURCES (INCLUDING REFERENCE DESIGNS), APPLICATION OR OTHER DESIGN ADVICE, WEB TOOLS, SAFETY INFORMATION, AND OTHER RESOURCES "AS IS" AND WITH ALL FAULTS, AND DISCLAIMS ALL WARRANTIES, EXPRESS AND IMPLIED, INCLUDING WITHOUT LIMITATION ANY IMPLIED WARRANTIES OF MERCHANTABILITY, FITNESS FOR A PARTICULAR PURPOSE OR NON-INFRINGEMENT OF THIRD PARTY INTELLECTUAL PROPERTY RIGHTS.

These resources are intended for skilled developers designing with TI products. You are solely responsible for (1) selecting the appropriate TI products for your application, (2) designing, validating and testing your application, and (3) ensuring your application meets applicable standards, and any other safety, security, or other requirements. These resources are subject to change without notice. TI grants you permission to use these resources only for development of an application that uses the TI products described in the resource. Other reproduction and display of these resources is prohibited. No license is granted to any other TI intellectual property right or to any third party intellectual property right. TI disclaims responsibility for, and you will fully indemnify TI and its representatives against, any claims, damages, costs, losses, and liabilities arising out of your use of these resources.

TI's products are provided subject to TI's Terms of Sale (www.ti.com/legal/termsofsale.html) or other applicable terms available either on ti.com or provided in conjunction with such TI products. TI's provision of these resources does not expand or otherwise alter TI's applicable warranties or warranty disclaimers for TI products.

Mailing Address: Texas Instruments, Post Office Box 655303, Dallas, Texas 75265
Copyright © 2018, Texas Instruments Incorporated

Looking for pricing, stock, or lifecycle information?

Click below to explore more details on WIN SOURCE:

-  [View LM5041AMTCX](#) on WIN SOURCE
-  [Texas Instruments](#) Information

Optimize Your Supply Chain with WIN SOURCE Solutions

-  Global Sourcing Solution
-  Obsolete Management
-  Cost Control Management
-  Shortage Management
-  Alternative Solution
-  Excess Inventory Management