



**THE DATASHEET OF  
LM70CIMMX-5/NOPB**



## LM70 SPI/MICROWIRE 10-Bit plus Sign Digital Temperature Sensor

Check for Samples: [LM70](#)

### FEATURES

- 0.25°C Temperature Resolution.
- Shutdown Mode Conserves Power Between Temperature Reading
- SPI and MICROWIRE Bus Interface
- VSSOP-8 and WSON-8 Packages Save Space
- UL Recognized Component 

### APPLICATIONS

- System Thermal Management
- Personal Computers
- Disk Drives
- Office Electronics
- Electronic Test Equipment

### KEY SPECIFICATIONS

- Supply Voltage 2.65V to 5.5V
- Supply Current
  - Operating
    - 260  $\mu$ A (typ)
    - 490  $\mu$ A (max)
  - Shutdown
    - 12  $\mu$ A (typ)
- Temperature Accuracy
  - -40°C to 85°C,  $\pm 2^\circ$ C(max)
  - -10°C to 65°C, +1.5/-2°C(max)
  - -55°C to 125°C, +3/-2°C(max)
  - -55°C to 150°C, +3.5/-2°C(max)

### DESCRIPTION

The LM70 is a temperature sensor, Delta-Sigma analog-to-digital converter with an SPI and MICROWIRE compatible interface available in WSON and VSSOP 8-pin packages. The host can query the LM70 at any time to read temperature. A shutdown mode decreases power consumption to less than 10  $\mu$ A. This mode is useful in systems where low average power consumption is critical.

The LM70 has 10-bit plus sign temperature resolution (0.25°C per LSB) while operating over a temperature range of -55°C to +150°C.

The LM70's 2.65V to 5.5V supply voltage range, low supply current and simple SPI interface make it ideal for a wide range of applications. These include thermal management and protection applications in hard disk drives, printers, electronic test equipment, and office electronics.



Please be aware that an important notice concerning availability, standard warranty, and use in critical applications of Texas Instruments semiconductor products and disclaimers thereto appears at the end of this data sheet.

All trademarks are the property of their respective owners.

### Simplified Block Diagram

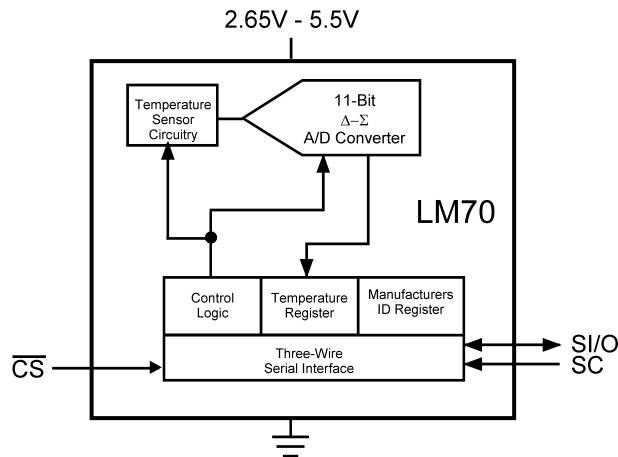

### Connection Diagram

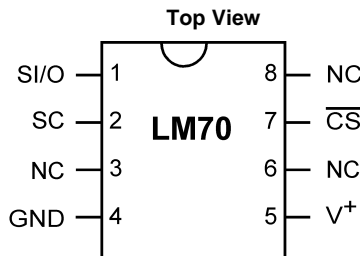

**Figure 1. VSSOP-8 Package**  
See Package Number DGK0008A

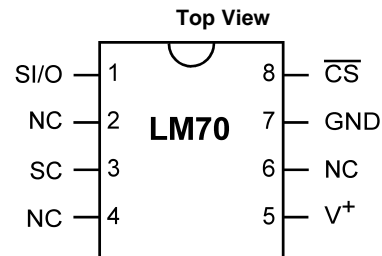

**Figure 2. WSON-8 Package**  
See Package Number NGK0008A

### PIN DESCRIPTIONS

Pin Name	VSSOP-8 Pin No.	WSON-8 Pin No.	Description	Typical Connection
SI/O	1	1	Input/Output - Serial bus bi-directional data line. Schmitt trigger input.	From and to Controller
SC	2	3	Clock - Serial bus clock Schmitt trigger input line.	From Controller
GND	4	7	Power Supply Ground	Ground
V <sup>+</sup>	5	5	Positive Supply Voltage Input	DC Voltage from 2.65V to 5.5V. Bypass with a 0.1 μF ceramic capacitor.
CS-bar	7	8	Chip Select input.	From Controller
NC	3, 6, 8	2, 4, 6	No Connect	These pins are not connected to the LM70 die in any way.

## Typical Application

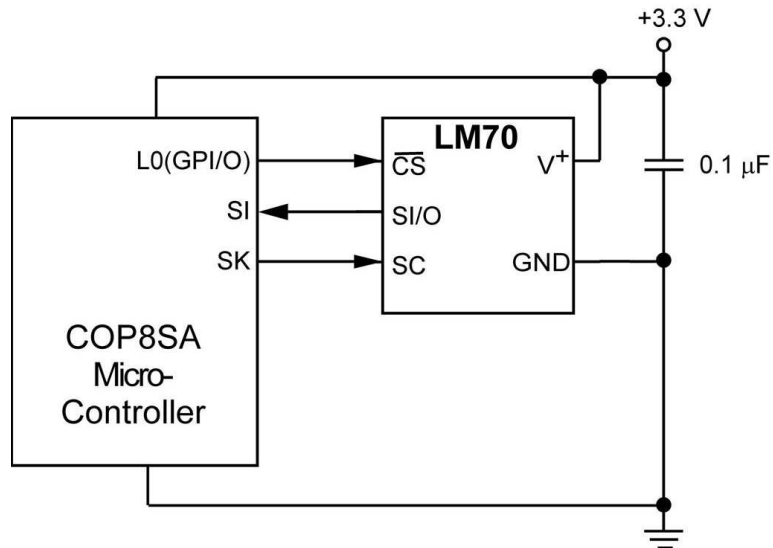

Figure 3. COP Microcontroller Interface



These devices have limited built-in ESD protection. The leads should be shorted together or the device placed in conductive foam during storage or handling to prevent electrostatic damage to the MOS gates.

## Absolute Maximum Ratings<sup>(1)</sup>

Supply Voltage	-0.3V to 6.0V
Voltage at any Pin	-0.3V to V <sup>+</sup> + 0.3V
Input Current at any Pin <sup>(2)</sup>	5 mA
Package Input Current <sup>(2)</sup>	20 mA
Storage Temperature	-65°C to +150°C
Soldering Information, Lead Temperature	
VSSOP-8 and WSON-8 Packages <sup>(3)</sup>	
Vapor Phase (60 seconds)	215°C
Infrared (15 seconds)	220°C
ESD Susceptibility <sup>(4)</sup>	
Human Body Model	3000V
Machine Model	300V

- (1) Absolute Maximum Ratings indicate limits beyond which damage to the device may occur. DC and AC electrical specifications do not apply when operating the device beyond its rated operating conditions.
- (2) When the input voltage (V<sub>I</sub>) at any pin exceeds the power supplies (V<sub>I</sub> < GND or V<sub>I</sub> > +V<sub>S</sub>) the current at that pin should be limited to 5 mA. The 20 mA maximum package input current rating limits the number of pins that can safely exceed the power supplies with an input current of 5 mA to four.
- (3) See the section titled "Surface Mount" found in a current Linear Data Book for other methods of soldering surface mount devices.
- (4) Human body model, 100 pF discharged through a 1.5 kΩ resistor. Machine model, 200 pF discharged directly into each pin.

## Operating Ratings

Specified Temperature Range	T <sub>MIN</sub> to T <sub>MAX</sub>
See <sup>(1)</sup>	-55°C to +150°C
Supply Voltage Range (+V <sub>S</sub> )	+2.65V to +5.5V

- (1) The life expectancy of the LM70 will be reduced when operating at elevated temperatures. LM70 θ<sub>JA</sub> (thermal resistance, junction-to-ambient) when attached to a printed circuit board with 2 oz. foil is summarized in the table below: Device Number LM70CILD Thermal Resistance (θ<sub>JA</sub>), 51.3°C/W, Device Number LM70C1MM Thermal Resistance (θ<sub>JA</sub>), 200°C/W

## Temperature-to-Digital Converter Characteristics

Unless otherwise noted, these specifications apply for V<sup>+</sup> = 2.65V to 3.6V for the LM70-3 and V<sup>+</sup> = 4.5V to 5.5V for the LM70-5<sup>(1)</sup>. **Boldface limits apply for T<sub>A</sub> = T<sub>J</sub> = T<sub>MIN</sub> to T<sub>MAX</sub>**; all other limits T<sub>A</sub> = T<sub>J</sub> = +25°C, unless otherwise noted.

Parameter	Test Conditions	Typical <sup>(2)</sup>	LM70-5 Limits <sup>(3)</sup>	LM70-3 Limits <sup>(3)</sup>	Units (Limit)
Temperature Error <sup>(1)</sup>	T <sub>A</sub> = -10°C to +65°C		<b>+1.5/-2.0</b>	<b>+1.5/-2.0</b>	°C (max)
	T <sub>A</sub> = -40°C to +85°C		<b>±2.0</b>	<b>±2.0</b>	°C (max)
	T <sub>A</sub> = -55°C to +125°C		<b>+3.0/-2.0</b>	<b>+3.0/-2.0</b>	°C (max)
	T <sub>A</sub> = -55°C to +150°C		<b>+3.5/-2.0</b>	<b>+3.5/-2.0</b>	°C (max)
Resolution		11 0.25			Bits °C
Temperature Conversion Time	See <sup>(4)</sup>	140	<b>210</b>	<b>210</b>	ms (max)
Quiescent Current	Serial Bus Inactive	260	<b>490</b>	<b>490</b>	μA (max)
	Serial Bus Active	260			μA
	Shutdown Mode	12			μA

- (1) Both part numbers of the LM70 will operate properly over the V<sup>+</sup> supply voltage range of 2.65V to 5.5V. The temperature error for temperature ranges of -10°C to +65°C, -40°C to +85°C, -55°C to +125°C and -55°C to +150°C include error induced by power supply variation of ±5% from the nominal value. Temperature error will increase by ±0.3°C for a power supply voltage (V<sup>+</sup>) variation of ±10% from the nominal value.
- (2) Typicals are at T<sub>A</sub> = 25°C and represent most likely parametric norm.
- (3) Limits are guaranteed to AOQL (Average Outgoing Quality Level).
- (4) This specification is provided only to indicate how often temperature data is updated. The LM70 can be read at any time without regard to conversion state (and will yield last conversion result). A conversion in progress will not be interrupted. The output shift register will be updated at the completion of the read and a new conversion restarted.

## Logic Electrical Characteristics Digital DC Characteristics

Unless otherwise noted, these specifications apply for  $V^+ = 2.65\text{V}$  to  $3.6\text{V}$  for the LM70-3 and  $V^+ = 4.5\text{V}$  to  $5.5\text{V}$  for the LM70-5. **Boldface limits apply for  $T_A = T_J = T_{\text{MIN}}$  to  $T_{\text{MAX}}$** ; all other limits  $T_A = T_J = +25^\circ\text{C}$ , unless otherwise noted.

Parameter		Test Conditions	Typical <sup>(1)</sup>	Limits <sup>(2)</sup>	Units (Limit)
$V_{\text{IN}(1)}$	Logical "1" Input Voltage			<b><math>V^+ \times 0.7</math></b>	V (min)
				<b><math>V^+ + 0.3</math></b>	V (max)
$V_{\text{IN}(0)}$	Logical "0" Input Voltage			<b>-0.3</b>	V (min)
				<b><math>V^+ \times 0.3</math></b>	V (max)
	Input Hysteresis Voltage	$V^+ = 2.65\text{V}$ to $3.6\text{V}$	0.8	<b>0.27</b>	V (min)
		$V^+ = 4.5\text{V}$ to $5.5\text{V}$	0.8	<b>0.35</b>	V (min)
$I_{\text{IN}(1)}$	Logical "1" Input Current	$V_{\text{IN}} = V^+$	0.005	<b>3.0</b>	$\mu\text{A}$ (max)
$I_{\text{IN}(0)}$	Logical "0" Input Current	$V_{\text{IN}} = 0\text{V}$	-0.005	<b>-3.0</b>	$\mu\text{A}$ (min)
$C_{\text{IN}}$	All Digital Inputs		20		pF
$V_{\text{OH}}$	High Level Output Voltage	$I_{\text{OH}} = -400 \mu\text{A}$		<b>2.4</b>	V (min)
$V_{\text{OL}}$	Low Level Output Voltage	$I_{\text{OL}} = +2 \text{mA}$		<b>0.4</b>	V (max)
$I_{\text{O\_TRI-STATE}}$	TRI-STATE Output Leakage Current	$V_{\text{O}} = \text{GND}$ $V_{\text{O}} = V^+$		<b>-1</b>	$\mu\text{A}$ (min)
				<b>+1</b>	$\mu\text{A}$ (max)

(1) Typicals are at  $T_A = 25^\circ\text{C}$  and represent most likely parametric norm.

(2) Limits are guaranteed to AOQL (Average Outgoing Quality Level).

## Logic Electrical Characteristics Serial Bus Digital Switching Characteristics

Unless otherwise noted, these specifications apply for  $V^+ = 2.65\text{V}$  to  $3.6\text{V}$  for the LM70-3 and  $V^+ = 4.5\text{V}$  to  $5.5\text{V}$  for the LM70-5.  $C_L$  (load capacitance) on output lines =  $100 \text{pF}$  unless otherwise specified. **Boldface limits apply for  $T_A = T_J = T_{\text{MIN}}$  to  $T_{\text{MAX}}$** ; all other limits  $T_A = T_J = +25^\circ\text{C}$ , unless otherwise noted.

Parameter		Test Conditions	Typical <sup>(1)</sup>	Limits <sup>(2)</sup>	Units (Limit)
$t_1$	SC (Clock) Period			<b>0.16</b> DC	$\mu\text{s}$ (min) (max)
$t_2$	$\overline{\text{CS}}$ Low to SC (Clock) High Set-Up Time			<b>100</b>	ns (min)
$t_3$	$\overline{\text{CS}}$ Low to Data Out (SO) Delay			<b>70</b>	ns (max)
$t_4$	SC (Clock) Low to Data Out (SO) Delay			<b>70</b>	ns (max)
$t_5$	$\overline{\text{CS}}$ High to Data Out (SO) TRI-STATE			<b>200</b>	ns (min)
$t_6$	SC (Clock) High to Data In (SI) Hold Time			<b>60</b>	ns (min)
$t_7$	Data In (SI) Set-Up Time to SC (Clock) High			<b>30</b>	ns (min)

(1) Typicals are at  $T_A = 25^\circ\text{C}$  and represent most likely parametric norm.

(2) Limits are guaranteed to AOQL (Average Outgoing Quality Level).

**Timing Diagrams**

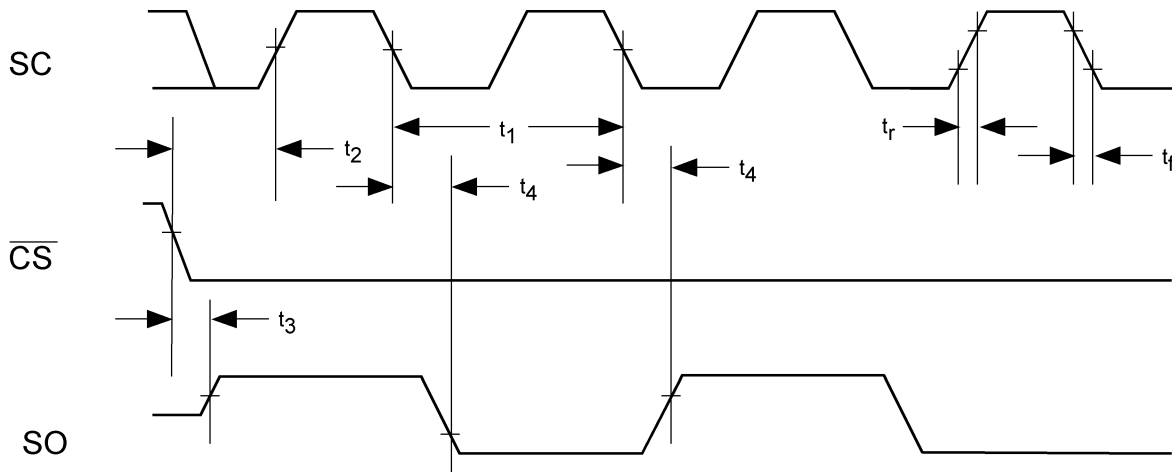

**Figure 4. Data Output Timing Diagram**

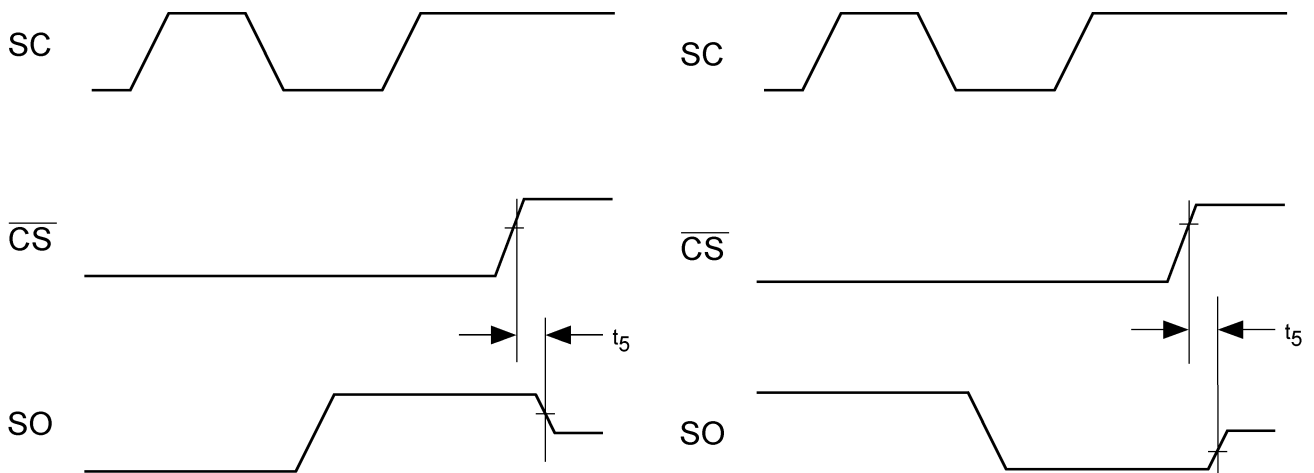

**Figure 5. TRI-STATE Data Output Timing Diagram**

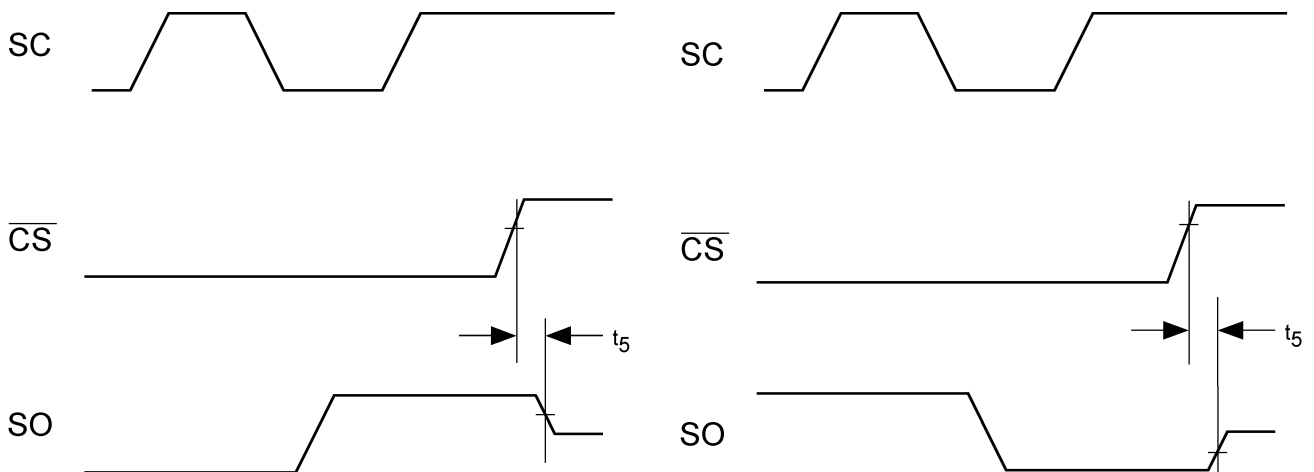

**Figure 6. Data Input Timing Diagram**

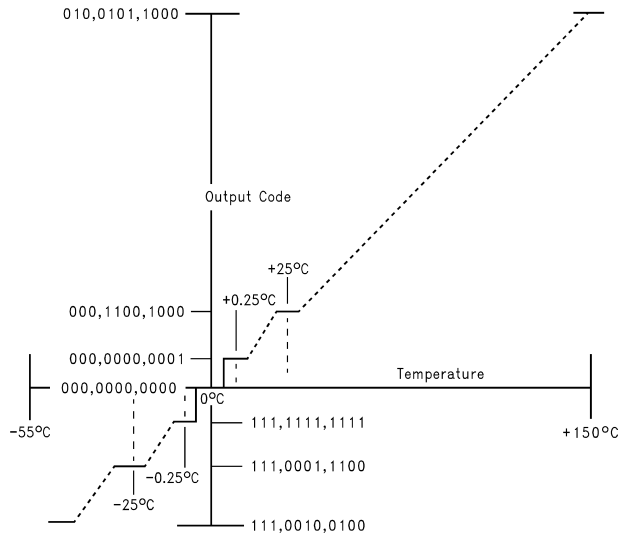

Figure 7. Temperature-to-Digital Transfer Function (Non-linear scale for clarity)

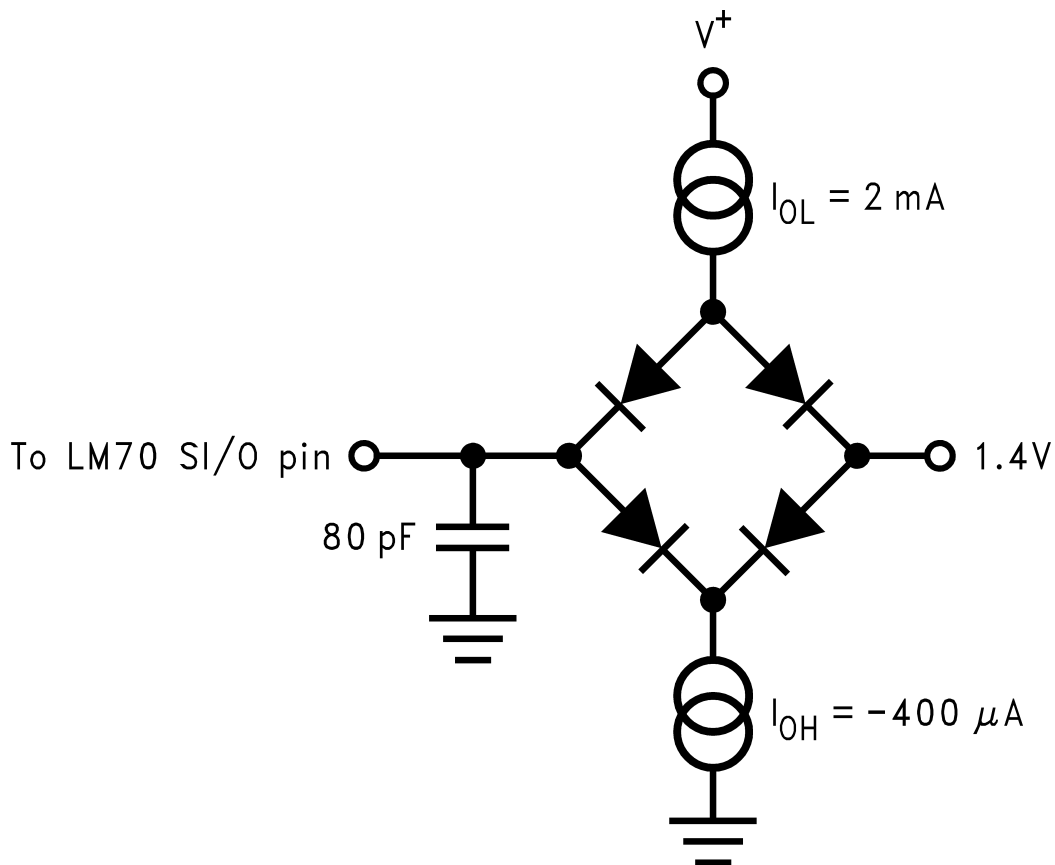

Figure 8. TRI-STATE Test Circuit

### Typical Performance Characteristics

Average Power-On Reset Voltage vs Temperature

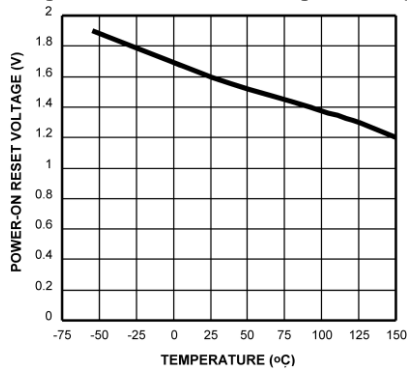

Figure 9.

Static Supply Current vs Temperature

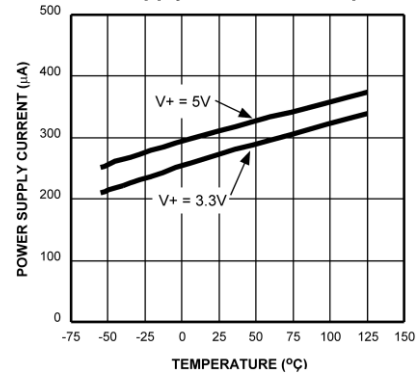

Figure 10.

Temperature Error

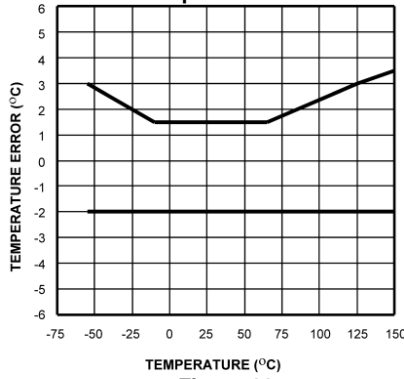

Figure 11.

## FUNCTIONAL DESCRIPTION

The LM70 temperature sensor incorporates a band-gap type temperature sensor and 10-bit plus sign  $\Delta\Sigma$  ADC (Delta-Sigma Analog-to-Digital Converter). Compatibility of the LM70's three wire serial interface with SPI and MICROWIRE allows simple communications with common microcontrollers and processors. Shutdown mode can be used to optimize current drain for different applications. A manufacturer's ID register identifies the LM70 as a TI product.

### POWER UP AND POWER DOWN

The LM70 always powers up in a known state. The power up default condition is continuous conversion mode. Immediately after power up the LM70 will output an erroneous code until the first temperature conversion has completed.

When the supply voltage is less than about 1.6V (typical), the LM70 is considered powered down. As the supply voltage rises above the nominal 1.6V power up threshold, the internal registers are reset to the power up default state described above.

### SERIAL BUS INTERFACE

The LM70 operates as a slave and is compatible with SPI or MICROWIRE bus specifications. Data is clocked out on the falling edge of the serial clock (SC), while data is clocked in on the rising edge of SC. A complete transmit/receive communication will consist of 32 serial clocks. The first 16 clocks comprise the transmit phase of communication, while the second 16 clocks are the receive phase.

When  $\overline{CS}$  is high SI/O will be in TRISTATE. Communication should be initiated by taking chip select ( $\overline{CS}$ ) low. This should not be done when SC is changing from a low to high state. Once  $\overline{CS}$  is low the serial I/O pin (SI/O) will transmit the first bit of data. The master can then read this bit with the rising edge of SC. The remainder of the data will be clocked out by the falling edge of SC. Once the 14 bits of data (one sign bit, ten temperature bits and 3 high bits) are transmitted the SI/O line will go into TRI-STATE.  $\overline{CS}$  can be taken high at any time during the transmit phase. If  $\overline{CS}$  is brought low in the middle of a conversion the LM70 will complete the conversion and the output shift register will be updated after  $\overline{CS}$  is brought back high.

The receive phase of a communication starts after 16 SC periods.  $\overline{CS}$  can remain low for 32 SC cycles. The LM70 will read the data available on the SI/O line on the rising edge of the serial clock. Input data is to an 8-bit shift register. The part will detect the last eight bits shifted into the register. The receive phase can last up to 16 SC periods. All ones must be shifted in order to place the part into shutdown. A zero in any location will take the LM70 out of shutdown. The following codes only should be transmitted to the LM70:

- 00 hex (normal operation)
- 01 hex (normal operation)
- 03 hex (normal operation)
- 07 hex (normal operation)
- 0F hex (normal operation)
- 1F hex (normal operation)
- 3F hex(normal operation)
- 7F hex(normal operation)
- FF hex (Shutdown, transmit manufacturer's ID)

any others may place the part into a Test Mode. Test Modes are used by TI to thoroughly test the function of the LM70 during production testing. Only eight bits have been defined above since only the last eight transmitted, before  $\overline{CS}$  is taken HIGH, are detected by the LM70

The following communication can be used to determine the Manufacturer's/Device ID and then immediately place the part into continuous conversion mode. With  $\overline{CS}$  continuously low:

- Read 16 bits of temperature data
- Write 16 bits of data commanding shutdown
- Read 16 bits of Manufacture's/Device ID data
- Write 8 to 16 bits of data commanding Conversion Mode
- Take  $\overline{CS}$  HIGH.

Note that 210 ms will have to pass for a conversion to complete before the LM70 actually transmits temperature data.

## TEMPERATURE DATA FORMAT

Temperature data is represented by a 11-bit, two's complement word with an LSB (Least Significant Bit) equal to 0.25°C:

Temperature	Digital Output	
	Binary	Hex
+150°C	0100 1011 0001 1111	4B 1Fh
+125°C	0011 1110 1001 1111	3E 9Fh
+25°C	0000 1100 1001 1111	0B 9Fh
+0.25°C	0000 0000 0011 1111	00 3Fh
0°C	0000 0000 0001 1111	00 1Fh
-0.25°C	1111 1111 1111 1111	FF FFh
-25°C	1111 0011 1001 1111	F3 9Fh
-55°C	1110 0100 1001 1111	E4 9Fh

Note: The last two bits are TRI-STATE and depicted as one in the table.

The first data byte is the most significant byte with most significant bit first, permitting only as much data as necessary to be read to determine temperature condition. For instance, if the first four bits of the temperature data indicate an overtemperature condition, the host processor could immediately take action to remedy the excessive temperatures.

## SHUTDOWN MODE/MANUFACTURER'S ID

Shutdown mode is enabled by writing XX FF to the LM70 as shown in [Figure 14c](#), and discussed in Section 1.2. The serial bus is still active when the LM70 is in shutdown. Current draw drops to less than 10  $\mu$ A between serial communications. When in shutdown mode the LM70 always will output 1000 0001 0000 00XX. This is the manufacturer's ID/Device ID information. The first 5-bits of the field (1000 0XXX) are reserved for manufacturer's ID.

## INTERNAL REGISTER STRUCTURE

The LM70 has three registers, the temperature register, the configuration register and the manufacturer's/device identification register. The temperature and manufacturer's/device identification registers are read only. The configuration register is write only.

### CONFIGURATION REGISTER

(Selects shutdown or continuous conversion modes):

**Table 1. (Write Only):**

D15	D14	D13	D12	D11	D10	D9	D8	D7	D6	D5	D4	D3	D2	D1	D0
X	X	X	X	X	X	X	X	Shutdown							

D0-D15 set to XX FF hex enables shutdown mode.

D0-D15 set to XX 00 hex enables continuous conversion mode.

Note: setting D0-D15 to any other values may place the LM70 into a manufacturer's test mode, upon which the LM70 will stop responding as described. These test modes are to be used for production testing only. See Section 1.2 Serial Bus Interface for a complete discussion.

TEMPERATURE REGISTER

Table 2. (Read Only):

D15	D14	D13	D12	D11	D10	D9	D8	D7	D6	D5	D4	D3	D2	D1	D0
MSB	Bit 9	Bit 8	Bit 7	Bit 6	Bit 5	Bit 4	Bit 3	Bit 2	Bit 1	LSB	1	1	1	X	X

D0–D1: Undefined. TRI-STATE will be output on SI/O.

D2–D4: Always set high.

D5–D15: Temperature Data. One LSB = 0.25°C. Two's complement format.

MANUFACTURER'S/DEVICE ID REGISTER

Table 3. (Read Only):

D15	D14	D13	D12	D11	D10	D9	D8	D7	D6	D5	D4	D3	D2	D1	D0
1	0	0	0	0	0	0	1	0	0	0	0	0	0	X	X

D0–D1: Undefined. TRI-STATE will be output on SI/O.

D2–D4: Always set LOW.

D5–D15: Manufacturer's ID Data. This register is accessed whenever the LM70 is in shutdown mode.

Serial Bus Timing Diagrams

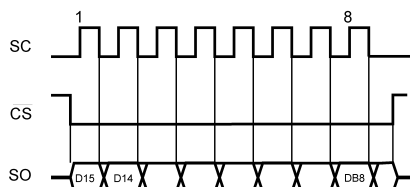

Figure 12. a) Reading Continuous Conversion - Single Eight-Bit Frame

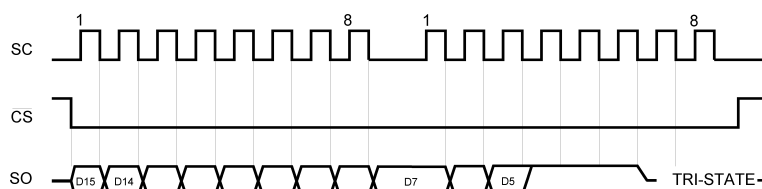

Figure 13. b) Reading Continuous Conversion - Two Eight-Bit Frames

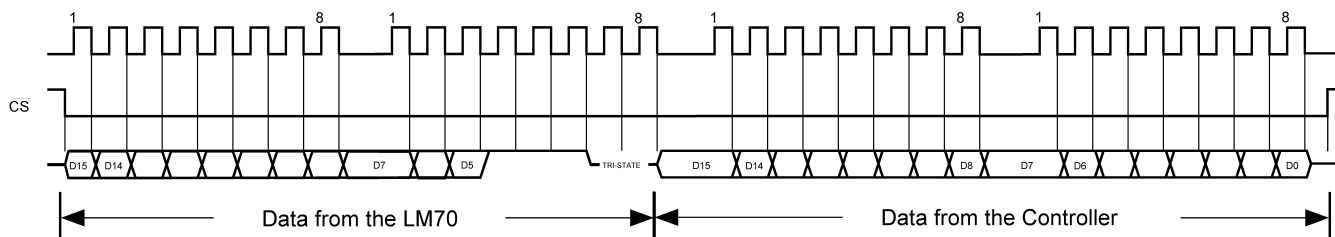

Figure 14. c) Writing Shutdown Control

## Application Hints

To get the expected results when measuring temperature with an integrated circuit temperature sensor like the LM70, it is important to understand that the sensor measures its own die temperature. For the LM70, the best thermal path between the die and the outside world is through the LM70's pins. In the VSSOP-8 package the ground pin is connected to the back side of the LM70 die and thus has the most effect on the die temperature. Although the other pins will also have some effect on the LM70 die temperature and therefore should not be discounted. The LM70 will provide an accurate measurement of the temperature of the printed circuit board on which it is mounted, because the pins represent a good thermal path to the die. A less efficient thermal path exists between the plastic package and the LM70 die. If the ambient air temperature is significantly different from the printed circuit board temperature, it will have a small effect on the measured temperature.

In probe-type applications, the LM70 can be mounted inside a sealed-end metal tube, and can then be dipped into a bath or screwed into a threaded hole in a tank. As with any IC, the LM70 and accompanying wiring and circuits must be kept insulated and dry, to avoid leakage and corrosion. This is especially true if the circuit may operate at cold temperatures where condensation can occur. Printed-circuit coatings and varnishes such as Humiseal and epoxy paints or dips are often used to insure that moisture cannot corrode the LM70 or its connections.

## Typical Applications

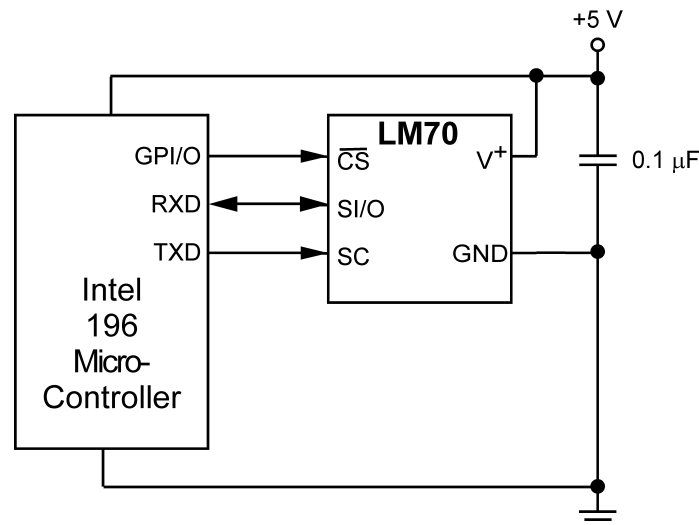

Figure 15. Temperature Monitor Using Intel 196 Processor

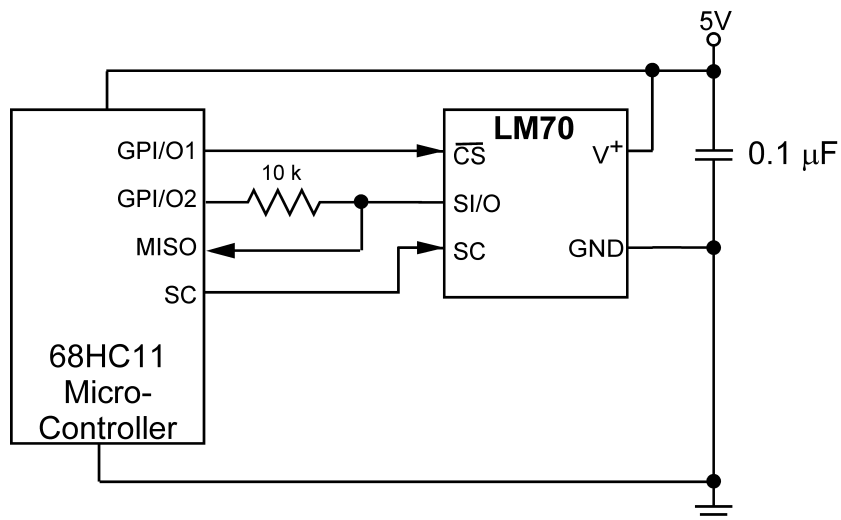

Figure 16. LM70 Digital Input Control Using Micro-Controller's General Purpose I/O

### REVISION HISTORY

Changes from Revision F (March 2013) to Revision G	Page
• Changed layout of National Data Sheet to TI format .....	<a href="#">13</a>

**PACKAGING INFORMATION**

Orderable Device	Status (1)	Package Type	Package Drawing	Pins	Package Qty	Eco Plan (2)	Lead/Ball Finish (6)	MSL Peak Temp (3)	Op Temp (°C)	Device Marking (4/5)	Samples
LM70CILD-3/NOPB	ACTIVE	WSO	NGK	8	1000	Green (RoHS & no Sb/Br)	CU SN	Level-3-260C-168 HR	-55 to 150	T33	<a href="#">Samples</a>
LM70CILD-5/NOPB	ACTIVE	WSO	NGK	8	1000	Green (RoHS & no Sb/Br)	CU SN	Level-3-260C-168 HR	-55 to 150	T35	<a href="#">Samples</a>
LM70CILD-3/NOPB	ACTIVE	WSO	NGK	8	4500	Green (RoHS & no Sb/Br)	CU SN	Level-3-260C-168 HR	-55 to 150	T33	<a href="#">Samples</a>
LM70CIMM-3	NRND	VSSOP	DGK	8	1000	TBD	Call TI	Call TI	-55 to 150	T04C	
LM70CIMM-3/NOPB	ACTIVE	VSSOP	DGK	8	1000	Green (RoHS & no Sb/Br)	CU SN	Level-1-260C-UNLIM	-55 to 150	T04C	<a href="#">Samples</a>
LM70CIMM-5	NRND	VSSOP	DGK	8	1000	TBD	Call TI	Call TI	-55 to 150	T03C	
LM70CIMM-5/NOPB	ACTIVE	VSSOP	DGK	8	1000	Green (RoHS & no Sb/Br)	CU SN	Level-1-260C-UNLIM	-55 to 150	T03C	<a href="#">Samples</a>
LM70CIMMX-3/NOPB	ACTIVE	VSSOP	DGK	8	3500	Green (RoHS & no Sb/Br)	CU SN	Level-1-260C-UNLIM	-55 to 150	T04C	<a href="#">Samples</a>
LM70CIMMX-5/NOPB	ACTIVE	VSSOP	DGK	8	3500	Green (RoHS & no Sb/Br)	CU SN	Level-1-260C-UNLIM	-55 to 150	T03C	<a href="#">Samples</a>

(1) The marketing status values are defined as follows:

**ACTIVE:** Product device recommended for new designs.

**LIFEBUY:** TI has announced that the device will be discontinued, and a lifetime-buy period is in effect.

**NRND:** Not recommended for new designs. Device is in production to support existing customers, but TI does not recommend using this part in a new design.

**PREVIEW:** Device has been announced but is not in production. Samples may or may not be available.

**OBSELETE:** TI has discontinued the production of the device.

(2) **RoHS:** TI defines "RoHS" to mean semiconductor products that are compliant with the current EU RoHS requirements for all 10 RoHS substances, including the requirement that RoHS substance do not exceed 0.1% by weight in homogeneous materials. Where designed to be soldered at high temperatures, "RoHS" products are suitable for use in specified lead-free processes. TI may reference these types of products as "Pb-Free".

**RoHS Exempt:** TI defines "RoHS Exempt" to mean products that contain lead but are compliant with EU RoHS pursuant to a specific EU RoHS exemption.

**Green:** TI defines "Green" to mean the content of Chlorine (Cl) and Bromine (Br) based flame retardants meet JS709B low halogen requirements of <=1000ppm threshold. Antimony trioxide based flame retardants must also meet the <=1000ppm threshold requirement.

(3) MSL, Peak Temp. - The Moisture Sensitivity Level rating according to the JEDEC industry standard classifications, and peak solder temperature.

(4) There may be additional marking, which relates to the logo, the lot trace code information, or the environmental category on the device.

<sup>(5)</sup> Multiple Device Markings will be inside parentheses. Only one Device Marking contained in parentheses and separated by a "-" will appear on a device. If a line is indented then it is a continuation of the previous line and the two combined represent the entire Device Marking for that device.

<sup>(6)</sup> Lead/Ball Finish - Orderable Devices may have multiple material finish options. Finish options are separated by a vertical ruled line. Lead/Ball Finish values may wrap to two lines if the finish value exceeds the maximum column width.

**Important Information and Disclaimer:**The information provided on this page represents TI's knowledge and belief as of the date that it is provided. TI bases its knowledge and belief on information provided by third parties, and makes no representation or warranty as to the accuracy of such information. Efforts are underway to better integrate information from third parties. TI has taken and continues to take reasonable steps to provide representative and accurate information but may not have conducted destructive testing or chemical analysis on incoming materials and chemicals. TI and TI suppliers consider certain information to be proprietary, and thus CAS numbers and other limited information may not be available for release.

In no event shall TI's liability arising out of such information exceed the total purchase price of the TI part(s) at issue in this document sold by TI to Customer on an annual basis.

**TAPE AND REEL INFORMATION**

**QUADRANT ASSIGNMENTS FOR PIN 1 ORIENTATION IN TAPE**

\*All dimensions are nominal

Device	Package Type	Package Drawing	Pins	SPQ	Reel Diameter (mm)	Reel Width W1 (mm)	A0 (mm)	B0 (mm)	K0 (mm)	P1 (mm)	W (mm)	Pin1 Quadrant
LM70CILD-3/NOPB	WSON	NGK	8	1000	178.0	12.4	3.3	3.3	1.0	8.0	12.0	Q1
LM70CILD-5/NOPB	WSON	NGK	8	1000	178.0	12.4	3.3	3.3	1.0	8.0	12.0	Q1
LM70CILD-3/NOPB	WSON	NGK	8	4500	330.0	12.4	3.3	3.3	1.0	8.0	12.0	Q1
LM70CIMM-3	VSSOP	DGK	8	1000	178.0	12.4	5.3	3.4	1.4	8.0	12.0	Q1
LM70CIMM-3/NOPB	VSSOP	DGK	8	1000	178.0	12.4	5.3	3.4	1.4	8.0	12.0	Q1
LM70CIMM-5	VSSOP	DGK	8	1000	178.0	12.4	5.3	3.4	1.4	8.0	12.0	Q1
LM70CIMM-5/NOPB	VSSOP	DGK	8	1000	178.0	12.4	5.3	3.4	1.4	8.0	12.0	Q1
LM70CIMMX-3/NOPB	VSSOP	DGK	8	3500	330.0	12.4	5.3	3.4	1.4	8.0	12.0	Q1
LM70CIMMX-5/NOPB	VSSOP	DGK	8	3500	330.0	12.4	5.3	3.4	1.4	8.0	12.0	Q1

**TAPE AND REEL BOX DIMENSIONS**

\*All dimensions are nominal

Device	Package Type	Package Drawing	Pins	SPQ	Length (mm)	Width (mm)	Height (mm)
LM70CILD-3/NOPB	WSON	NGK	8	1000	210.0	185.0	35.0
LM70CILD-5/NOPB	WSON	NGK	8	1000	210.0	185.0	35.0
LM70CILD-3/NOPB	WSON	NGK	8	4500	367.0	367.0	35.0
LM70CIMM-3	VSSOP	DGK	8	1000	210.0	185.0	35.0
LM70CIMM-3/NOPB	VSSOP	DGK	8	1000	210.0	185.0	35.0
LM70CIMM-5	VSSOP	DGK	8	1000	210.0	185.0	35.0
LM70CIMM-5/NOPB	VSSOP	DGK	8	1000	210.0	185.0	35.0
LM70CIMMX-3/NOPB	VSSOP	DGK	8	3500	367.0	367.0	35.0
LM70CIMMX-5/NOPB	VSSOP	DGK	8	3500	367.0	367.0	35.0

NGK0008A

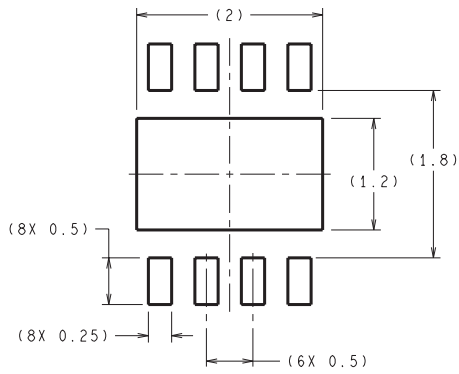

DIMENSIONS ARE IN MILLIMETERS

**RECOMMENDED LAND PATTERN**  
1:1 RATIO WITH PKG SOLDER PADS

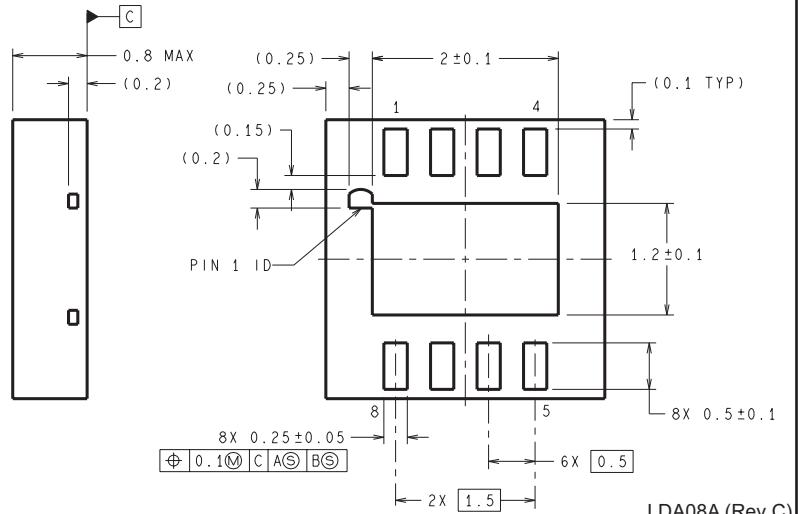
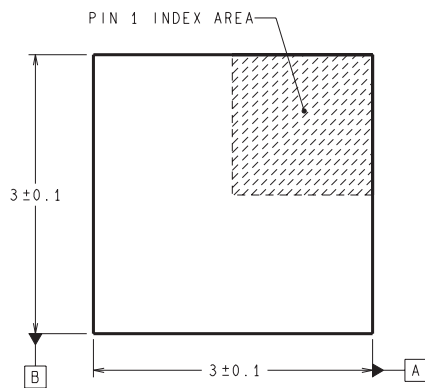

LDA08A (Rev C)





- NOTES:
- A. All linear dimensions are in millimeters.
  - B. This drawing is subject to change without notice.
  - C. Publication IPC-7351 is recommended for alternate designs.
  - D. Laser cutting apertures with trapezoidal walls and also rounding corners will offer better paste release. Customers should contact their board assembly site for stencil design recommendations. Refer to IPC-7525 for other stencil recommendations.
  - E. Customers should contact their board fabrication site for solder mask tolerances between and around signal pads.

## IMPORTANT NOTICE

Texas Instruments Incorporated (TI) reserves the right to make corrections, enhancements, improvements and other changes to its semiconductor products and services per JESD46, latest issue, and to discontinue any product or service per JESD48, latest issue. Buyers should obtain the latest relevant information before placing orders and should verify that such information is current and complete.

TI's published terms of sale for semiconductor products (<http://www.ti.com/sc/docs/stdterms.htm>) apply to the sale of packaged integrated circuit products that TI has qualified and released to market. Additional terms may apply to the use or sale of other types of TI products and services.

Reproduction of significant portions of TI information in TI data sheets is permissible only if reproduction is without alteration and is accompanied by all associated warranties, conditions, limitations, and notices. TI is not responsible or liable for such reproduced documentation. Information of third parties may be subject to additional restrictions. Resale of TI products or services with statements different from or beyond the parameters stated by TI for that product or service voids all express and any implied warranties for the associated TI product or service and is an unfair and deceptive business practice. TI is not responsible or liable for any such statements.

Buyers and others who are developing systems that incorporate TI products (collectively, "Designers") understand and agree that Designers remain responsible for using their independent analysis, evaluation and judgment in designing their applications and that Designers have full and exclusive responsibility to assure the safety of Designers' applications and compliance of their applications (and of all TI products used in or for Designers' applications) with all applicable regulations, laws and other applicable requirements. Designer represents that, with respect to their applications, Designer has all the necessary expertise to create and implement safeguards that (1) anticipate dangerous consequences of failures, (2) monitor failures and their consequences, and (3) lessen the likelihood of failures that might cause harm and take appropriate actions. Designer agrees that prior to using or distributing any applications that include TI products, Designer will thoroughly test such applications and the functionality of such TI products as used in such applications.

TI's provision of technical, application or other design advice, quality characterization, reliability data or other services or information, including, but not limited to, reference designs and materials relating to evaluation modules, (collectively, "TI Resources") are intended to assist designers who are developing applications that incorporate TI products; by downloading, accessing or using TI Resources in any way, Designer (individually or, if Designer is acting on behalf of a company, Designer's company) agrees to use any particular TI Resource solely for this purpose and subject to the terms of this Notice.

TI's provision of TI Resources does not expand or otherwise alter TI's applicable published warranties or warranty disclaimers for TI products, and no additional obligations or liabilities arise from TI providing such TI Resources. TI reserves the right to make corrections, enhancements, improvements and other changes to its TI Resources. TI has not conducted any testing other than that specifically described in the published documentation for a particular TI Resource.

Designer is authorized to use, copy and modify any individual TI Resource only in connection with the development of applications that include the TI product(s) identified in such TI Resource. NO OTHER LICENSE, EXPRESS OR IMPLIED, BY ESTOPPEL OR OTHERWISE TO ANY OTHER TI INTELLECTUAL PROPERTY RIGHT, AND NO LICENSE TO ANY TECHNOLOGY OR INTELLECTUAL PROPERTY RIGHT OF TI OR ANY THIRD PARTY IS GRANTED HEREIN, including but not limited to any patent right, copyright, mask work right, or other intellectual property right relating to any combination, machine, or process in which TI products or services are used. Information regarding or referencing third-party products or services does not constitute a license to use such products or services, or a warranty or endorsement thereof. Use of TI Resources may require a license from a third party under the patents or other intellectual property of the third party, or a license from TI under the patents or other intellectual property of TI.

TI RESOURCES ARE PROVIDED "AS IS" AND WITH ALL FAULTS. TI DISCLAIMS ALL OTHER WARRANTIES OR REPRESENTATIONS, EXPRESS OR IMPLIED, REGARDING RESOURCES OR USE THEREOF, INCLUDING BUT NOT LIMITED TO ACCURACY OR COMPLETENESS, TITLE, ANY EPIDEMIC FAILURE WARRANTY AND ANY IMPLIED WARRANTIES OF MERCHANTABILITY, FITNESS FOR A PARTICULAR PURPOSE, AND NON-INFRINGEMENT OF ANY THIRD PARTY INTELLECTUAL PROPERTY RIGHTS. TI SHALL NOT BE LIABLE FOR AND SHALL NOT DEFEND OR INDEMNIFY DESIGNER AGAINST ANY CLAIM, INCLUDING BUT NOT LIMITED TO ANY INFRINGEMENT CLAIM THAT RELATES TO OR IS BASED ON ANY COMBINATION OF PRODUCTS EVEN IF DESCRIBED IN TI RESOURCES OR OTHERWISE. IN NO EVENT SHALL TI BE LIABLE FOR ANY ACTUAL, DIRECT, SPECIAL, COLLATERAL, INDIRECT, PUNITIVE, INCIDENTAL, CONSEQUENTIAL OR EXEMPLARY DAMAGES IN CONNECTION WITH OR ARISING OUT OF TI RESOURCES OR USE THEREOF, AND REGARDLESS OF WHETHER TI HAS BEEN ADVISED OF THE POSSIBILITY OF SUCH DAMAGES.

Unless TI has explicitly designated an individual product as meeting the requirements of a particular industry standard (e.g., ISO/TS 16949 and ISO 26262), TI is not responsible for any failure to meet such industry standard requirements.



Where TI specifically promotes products as facilitating functional safety or as compliant with industry functional safety standards, such products are intended to help enable customers to design and create their own applications that meet applicable functional safety standards and requirements. Using products in an application does not by itself establish any safety features in the application. Designers must ensure compliance with safety-related requirements and standards applicable to their applications. Designer may not use any TI products in life-critical medical equipment unless authorized officers of the parties have executed a special contract specifically governing such use. Life-critical medical equipment is medical equipment where failure of such equipment would cause serious bodily injury or death (e.g., life support, pacemakers, defibrillators, heart pumps, neurostimulators, and implantables). Such equipment includes, without limitation, all medical devices identified by the U.S. Food and Drug Administration as Class III devices and equivalent classifications outside the U.S.

TI may expressly designate certain products as completing a particular qualification (e.g., Q100, Military Grade, or Enhanced Product). Designers agree that it has the necessary expertise to select the product with the appropriate qualification designation for their applications and that proper product selection is at Designers' own risk. Designers are solely responsible for compliance with all legal and regulatory requirements in connection with such selection.

Designer will fully indemnify TI and its representatives against any damages, costs, losses, and/or liabilities arising out of Designer's non-compliance with the terms and provisions of this Notice.

## Looking for pricing, stock, or lifecycle information?

Click below to explore more details on WIN SOURCE:

-  [View LM70CIMMX-5/NOPB on WIN SOURCE](#)
-  [Texas Instruments](#) Information

## Optimize Your Supply Chain with WIN SOURCE Solutions

-  Global Sourcing Solution
-  Obsolete Management
-  Cost Control Management
-  Shortage Management
-  Alternative Solution
-  Excess Inventory Management