



# THE DATASHEET OF LM725CN



## LM725 Operational Amplifier

Check for Samples: [LM725](#)

### FEATURES

- High Open Loop Gain: 3,000,000
- Low Input Voltage Drift 0.6  $\mu\text{V}/^\circ\text{C}$
- High Common Mode Rejection 120 dB
- Low Input Noise Current 0.15  $\text{pA}/\sqrt{\text{Hz}}$
- Low Input Offset Current 2 nA
- High Input Voltage Range  $\pm 14\text{V}$
- Wide Power Supply Range  $\pm 3\text{V}$  to  $\pm 22\text{V}$
- Offset Null Capability
- Output Short Circuit Protection

### CONNECTION DIAGRAM

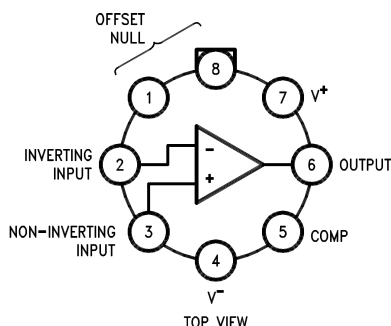

#### Metal Can Package

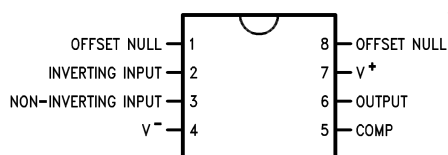

#### Dual-In-Line Package

### DESCRIPTION

The LM725/LM725A/LM725C are operational amplifiers featuring superior performance in applications where low noise, low drift, and accurate closed-loop gain are required. With high common mode rejection and offset null capability, it is especially suited for low level instrumentation applications over a wide supply voltage range.

The LM725A has tightened electrical performance with higher input accuracy and like the LM725, is guaranteed over a  $-55^\circ\text{C}$  to  $+125^\circ\text{C}$  temperature range. The LM725C has slightly relaxed specifications and has its performance guaranteed over a  $0^\circ\text{C}$  to  $70^\circ\text{C}$  temperature range.

### TYPICAL APPLICATIONS

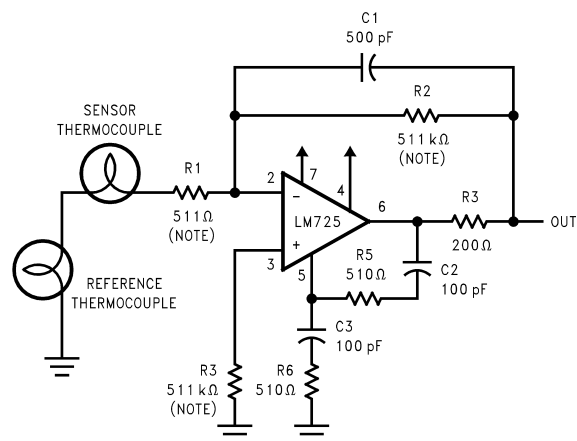

Figure 1. Thermocouple Amplifier



Please be aware that an important notice concerning availability, standard warranty, and use in critical applications of Texas Instruments semiconductor products and disclaimers thereto appears at the end of this data sheet.

All trademarks are the property of their respective owners.



These devices have limited built-in ESD protection. The leads should be shorted together or the device placed in conductive foam during storage or handling to prevent electrostatic damage to the MOS gates.

## ABSOLUTE MAXIMUM RATINGS <sup>(1)</sup>

If Military/Aerospace specified devices are required, contact the Texas Instruments Semiconductor Sales Office/ Distributors for availability and specifications. <sup>(2)</sup>

Supply Voltage	±22V
Internal Power Dissipation <sup>(3)</sup>	500 mW
Differential Input Voltage	±5V
Input Voltage <sup>(4)</sup>	±22V
Storage Temperature Range	-65°C to +150°C
Lead Temperature (Soldering, 10 Sec.)	260°C
Maximum Junction Temperature	150°C
Operating Temperature Range (T <sub>A(MIN)</sub> to T <sub>A(MAX)</sub> )	
LM725	-55°C to +125°C
LM725A	-55°C to +125°C
LM725C	0°C to +70°C

- (1) "Absolute Maximum Ratings" indicate limits beyond which damage to the device may occur. Operating Ratings indicate conditions for which the device is functional, but **do not** guarantee specific performance limits.
- (2) For Military electrical specifications RETS725AX are available for LM725AH and RETS725X are available for LM725H.
- (3) Derate at 150°C/W for operation at ambient temperatures above 75°C.
- (4) For supply voltages less than ±22V, the absolute maximum input voltage is equal to the supply voltage.

**ELECTRICAL CHARACTERISTICS (1)**

Parameter	Conditions	LM725A			LM725			LM725C			Units
		Min	Typ	Max	Min	Typ	Max	Min	Typ	Max	
Input Offset Voltage (Without External Trim)	$T_A = 25^\circ\text{C}$ , $R_S \leq 10\text{ k}\Omega$			0.5		0.5	1.0		0.5	2.5	mV
Input Offset Current	$T_A = 25^\circ\text{C}$		2.0	5.0		2.0	20		2.0	35	nA
Input Bias Current	$T_A = 25^\circ\text{C}$		42	80		42	100		42	125	nA
Input Noise Voltage	$T_A = 25^\circ\text{C}$										
	$f_o = 10\text{ Hz}$		15			15			15		$\text{nV}/\sqrt{\text{Hz}}$
	$f_o = 100\text{ Hz}$		9.0			9.0			9.0		$\text{nV}/\sqrt{\text{Hz}}$
	$f_o = 1\text{ kHz}$		8.0			8.0			8.0		$\text{nV}/\sqrt{\text{Hz}}$
Input Noise Current	$T_A = 25^\circ\text{C}$										
	$f_o = 10\text{ Hz}$		1.0			1.0			1.0		$\text{pA}/\sqrt{\text{Hz}}$
	$f_o = 100\text{ Hz}$		0.3			0.3			0.3		$\text{pA}/\sqrt{\text{Hz}}$
	$f_o = 1\text{ kHz}$		0.15			0.15			0.15		$\text{pA}/\sqrt{\text{Hz}}$
Input Resistance	$T_A = 25^\circ\text{C}$		1.5			1.5			1.5		M $\Omega$
Input Voltage Range	$T_A = 25^\circ\text{C}$	$\pm 13.5$	$\pm 14$		$\pm 13.5$	$\pm 14$		$\pm 13.5$	$\pm 14$		V
Large Signal Voltage Gain	$T_A = 25^\circ\text{C}$ , $R_L \geq 2\text{ k}\Omega$ , $V_{\text{OUT}} = \pm 10\text{V}$	1000	3000		1000	3000		250	3000		V/mV
Common-Mode Rejection Ratio	$T_A = 25^\circ\text{C}$ , $R_S \leq 10\text{ k}\Omega$	120			110	120		94	120		dB
Power Supply Rejection Ratio	$T_A = 25^\circ\text{C}$ , $R_S \leq 10\text{ k}\Omega$		2.0	5.0		2.0	10		2.0	35	$\mu\text{V}/\text{V}$
Output Voltage Swing	$T_A = 25^\circ\text{C}$ , $R_L \geq 10\text{ k}\Omega$	$\pm 12.5$	$\pm 13.5$		$\pm 12$	$\pm 13.5$		$\pm 12$	$\pm 13.5$		V
	$R_L \geq 2\text{ k}\Omega$	$\pm 12.0$	$\pm 13.5$		$\pm 10$	$\pm 13.5$		$\pm 10$	$\pm 13.5$		V
Power Consumption	$T_A = 25^\circ\text{C}$		80	105		80	105		80	150	mW
Input Offset Voltage (Without External Trim)	$R_S \leq 10\text{ k}\Omega$			0.7			1.5			3.5	mV
Average Input Offset Voltage Drift (Without External Trim)	$R_S = 50\Omega$			2.0		2.0	5.0		2.0		$\mu\text{V}/^\circ\text{C}$
Average Input Offset Voltage Drift (With External Trim)	$R_S = 50\Omega$		0.6	1.0		0.6			0.6		$\mu\text{V}/^\circ\text{C}$
Input Offset Current	$T_A = T_{\text{MAX}}$		1.2	4.0		1.2	20		1.2	35	nA
	$T_A = T_{\text{MIN}}$		7.5	18.0		7.5	40		4.0	50	nA
Average Input Offset Current Drift			35	90		35	150		10		$\text{pA}/^\circ\text{C}$
Input Bias Current	$T_A = T_{\text{MAX}}$		20	70		20	100			125	nA
	$T_A = T_{\text{MIN}}$		80	180		80	200			250	nA
Large Signal Voltage Gain	$R_L \geq 2\text{ k}\Omega$										
	$T_A = T_{\text{MAX}}$ , $R_L \geq 2\text{ k}\Omega$	1,000,000			1,000,000			125,000			V/V
	$T_A = T_{\text{MIN}}$	500,000			250,000			125,000			V/V
Common-Mode Rejection Ratio	$R_S \leq 10\text{ k}\Omega$	110			100				115		dB
Power Supply Rejection Ratio	$R_S \leq 10\text{ k}\Omega$			8.0			20		20		$\mu\text{V}/\text{V}$
Output Voltage Swing	$R_L \geq 2\text{ k}\Omega$	$\pm 12$			$\pm 10$			$\pm 10$			V

 (1) These specifications apply for  $V_S = \pm 15\text{V}$  unless otherwise specified.

### SCHEMATIC DIAGRAM

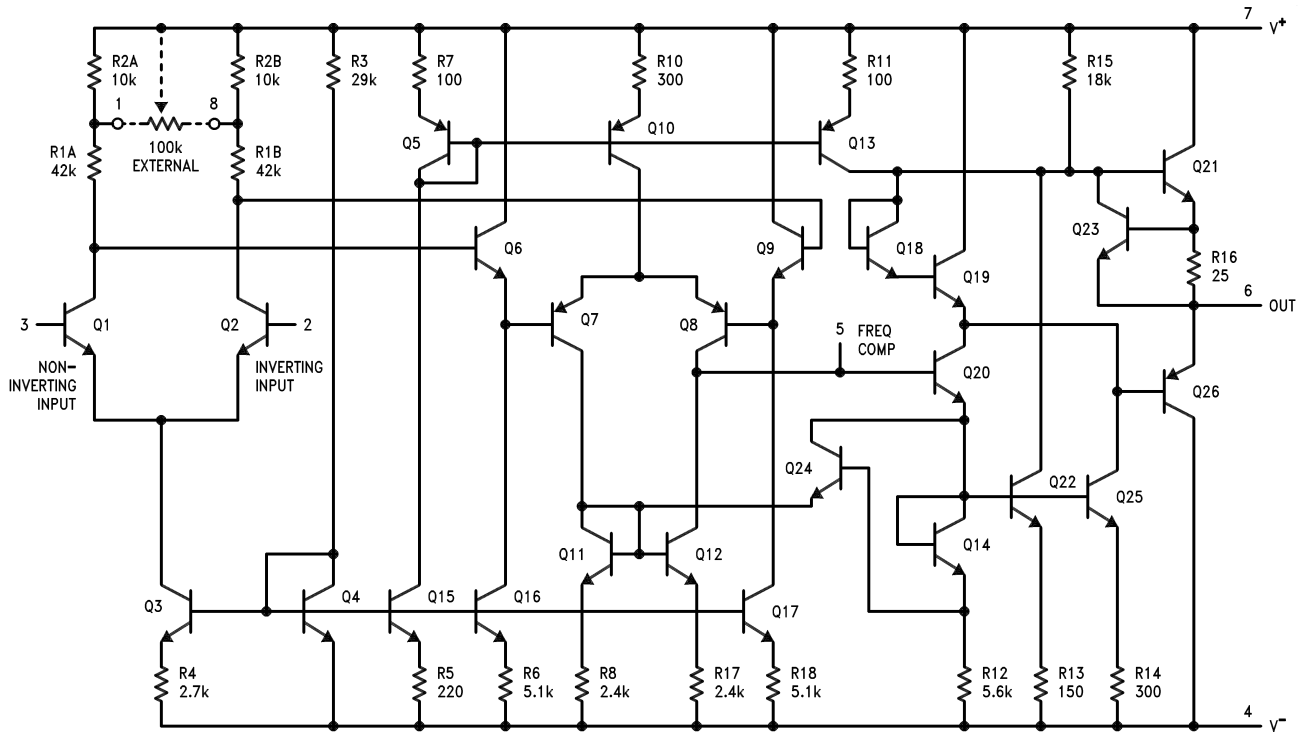

TYPICAL PERFORMANCE CHARACTERISTICS

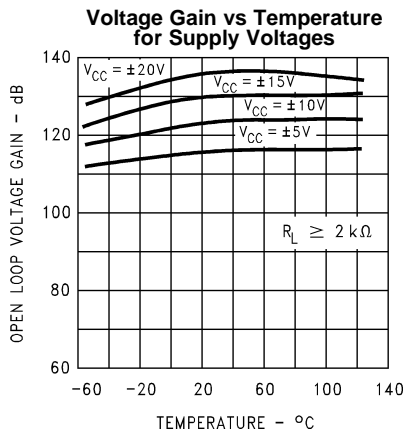

Figure 2.

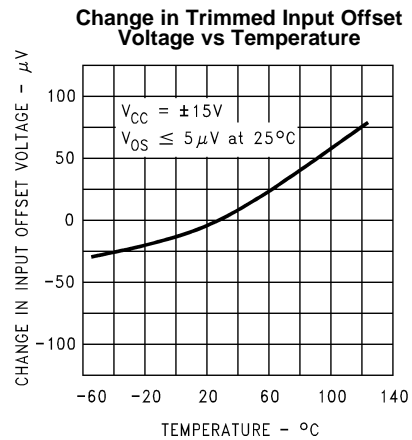

Figure 3.

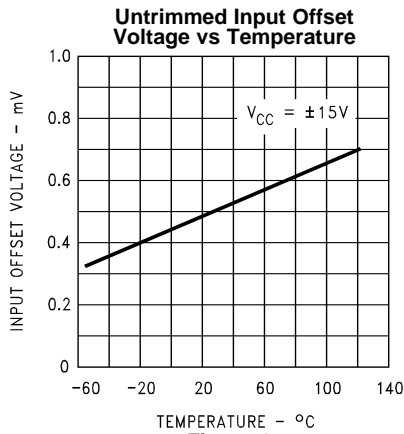

Figure 4.

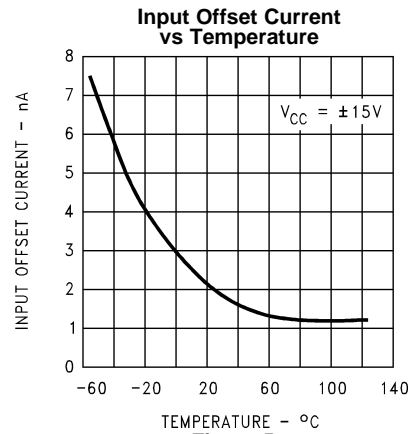

Figure 5.

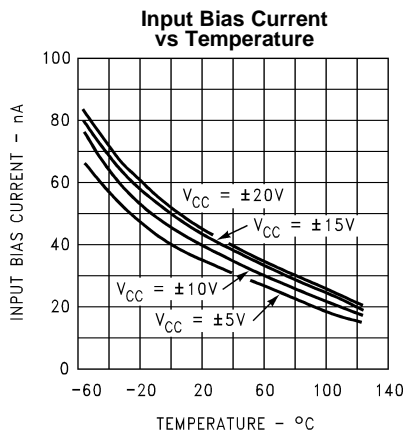

Figure 6.

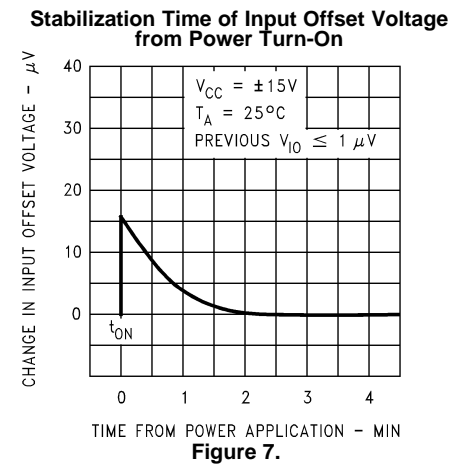

Figure 7.

**TYPICAL PERFORMANCE CHARACTERISTICS (continued)**

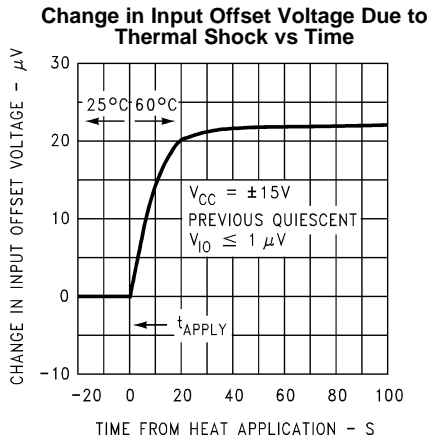

Figure 8.

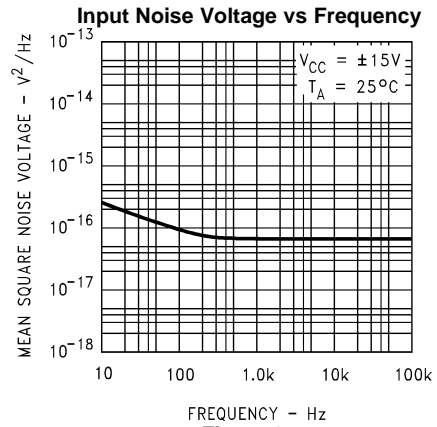

Figure 9.

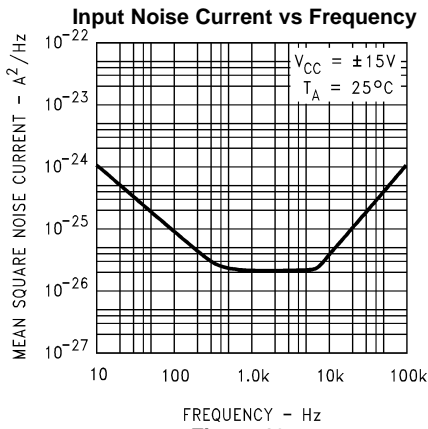

Figure 10.

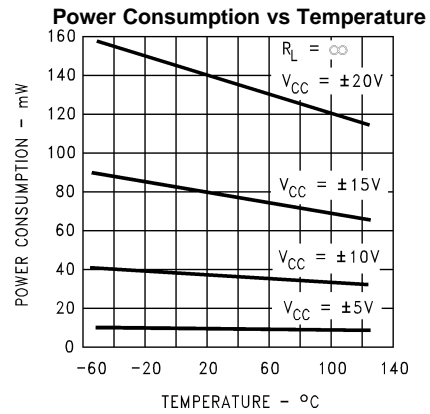

Figure 11.

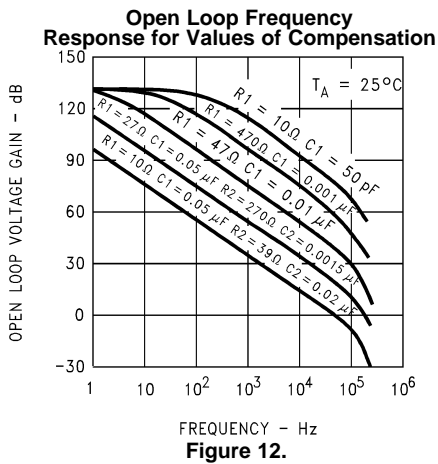

Figure 12.

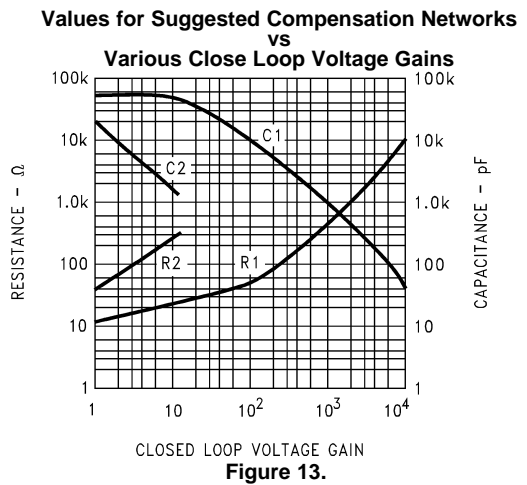
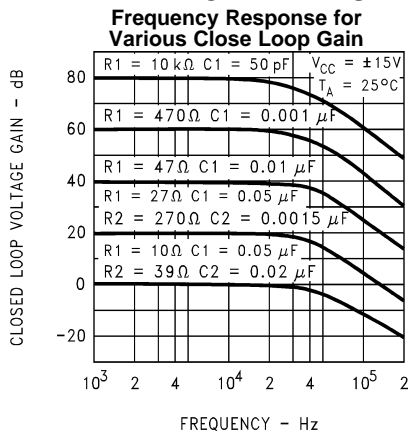

Figure 13.

**TYPICAL PERFORMANCE CHARACTERISTICS (continued)**



(1) Performance is shown using recommended compensation networks.

Figure 14.

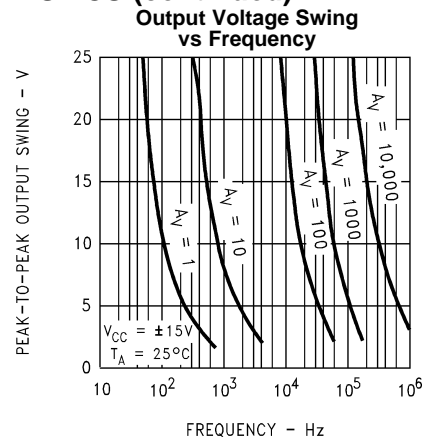

(1) Performance is shown using recommended compensation networks.

Figure 15.

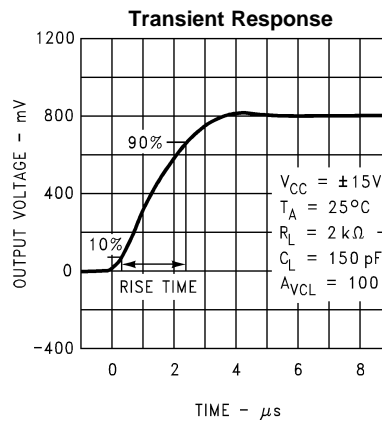

Figure 16.

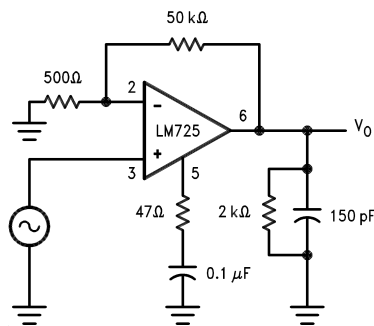

Figure 17. Transient Response Test Circuit

## AUXILIARY CIRCUITS

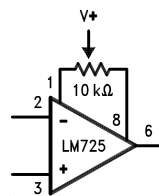

Figure 18. Voltage Offset Null Circuit

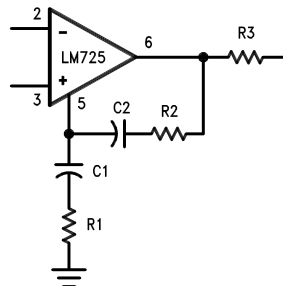
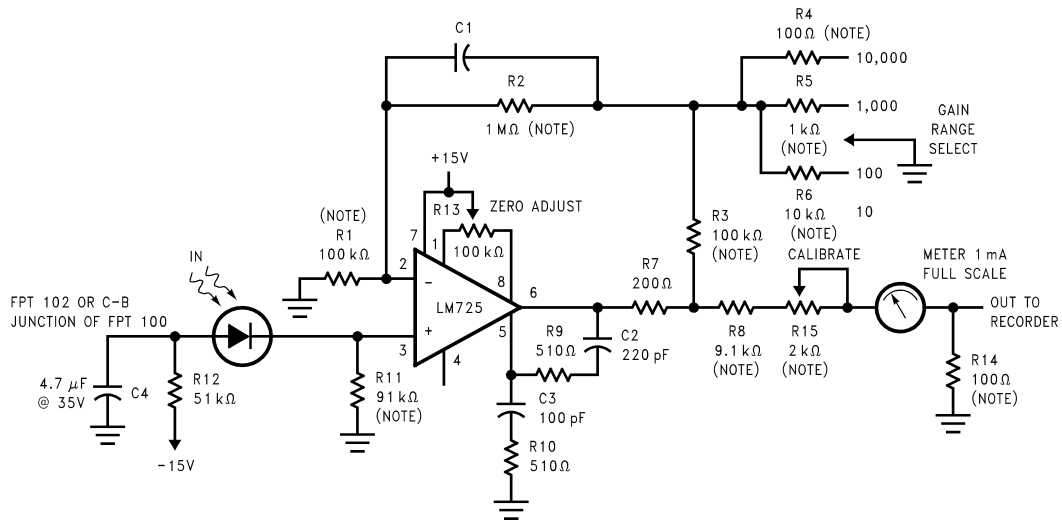

Figure 19. Frequency Compensation Circuit

Table 1. Compensation Component Values

$A_v$	$R_1$ ( $\Omega$ )	$C_1$ ( $\mu\text{F}$ )	$R_2$ ( $\Omega$ )	$C_2$ ( $\mu\text{F}$ )
10,000	10k	50 pF		
1,000	470	0.001		
100	47	0.01		
10	27	0.05	270	0.0015
1	10	0.05	39	0.02

TYPICAL APPLICATIONS



DC Gains = 10,000; 1,000; 100; and 10  
 Bandwidth = Determined by value of C1

Figure 20. Photodiode Amplifier

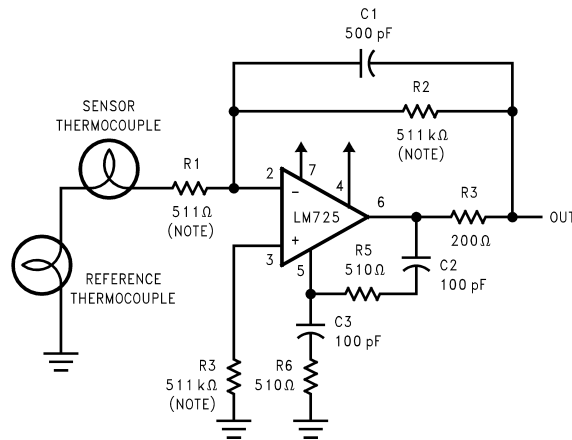

$$\frac{R2}{R5} = \frac{R6}{R7} \text{ for best CMR}$$

$$R1 = R4$$

$$R2 = R5$$

$$\text{Gain} = \frac{R6}{R2} + \left( \frac{2R1}{R3} \right)$$

DC Gain = 1000

Bandwidth = DC to 540 Hz

Equivalent Input Noise = 0.24  $\mu\text{V}_{\text{rms}}$

Indicates  $\pm 1\%$  metal film resistors recommended for temperature stability.

Figure 21. Thermocouple Amplifier

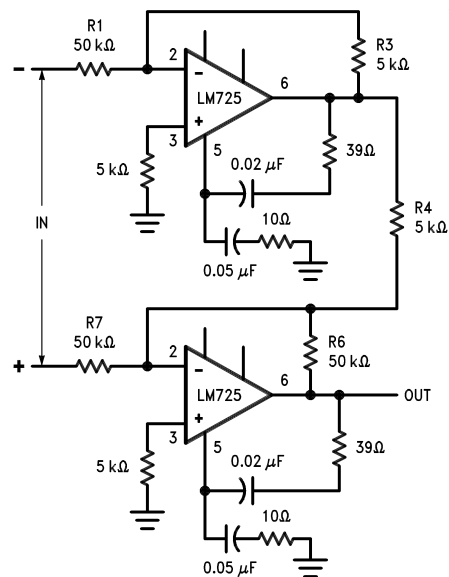

**Figure 22. ±100V Common Mode Range Differential Amplifier**

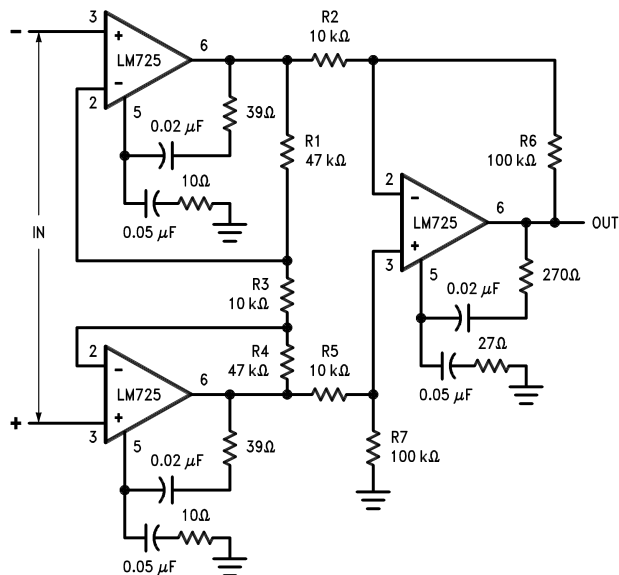

$$\frac{R1}{R6} = \frac{R3}{R4} \text{ for best CMRR}$$

$$R3 = R4$$

$$R1 = R6 = 10 R3$$

$$\text{Gain} = \frac{R6}{R7}$$

**Figure 23. Instrumentation Amplifier with High Common Mode Rejection**

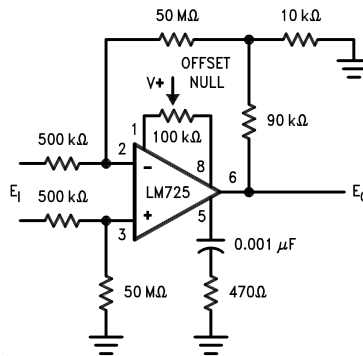

Figure 24. Precision Amplifier  $A_{VCL} = 1000$

## REVISION HISTORY

Changes from Revision C (April 2013) to Revision D	Page
• Changed layout of National Data Sheet to TI format .....	11

## IMPORTANT NOTICE

Texas Instruments Incorporated and its subsidiaries (TI) reserve the right to make corrections, enhancements, improvements and other changes to its semiconductor products and services per JESD46, latest issue, and to discontinue any product or service per JESD48, latest issue. Buyers should obtain the latest relevant information before placing orders and should verify that such information is current and complete. All semiconductor products (also referred to herein as "components") are sold subject to TI's terms and conditions of sale supplied at the time of order acknowledgment.

TI warrants performance of its components to the specifications applicable at the time of sale, in accordance with the warranty in TI's terms and conditions of sale of semiconductor products. Testing and other quality control techniques are used to the extent TI deems necessary to support this warranty. Except where mandated by applicable law, testing of all parameters of each component is not necessarily performed.

TI assumes no liability for applications assistance or the design of Buyers' products. Buyers are responsible for their products and applications using TI components. To minimize the risks associated with Buyers' products and applications, Buyers should provide adequate design and operating safeguards.

TI does not warrant or represent that any license, either express or implied, is granted under any patent right, copyright, mask work right, or other intellectual property right relating to any combination, machine, or process in which TI components or services are used. Information published by TI regarding third-party products or services does not constitute a license to use such products or services or a warranty or endorsement thereof. Use of such information may require a license from a third party under the patents or other intellectual property of the third party, or a license from TI under the patents or other intellectual property of TI.

Reproduction of significant portions of TI information in TI data books or data sheets is permissible only if reproduction is without alteration and is accompanied by all associated warranties, conditions, limitations, and notices. TI is not responsible or liable for such altered documentation. Information of third parties may be subject to additional restrictions.

Resale of TI components or services with statements different from or beyond the parameters stated by TI for that component or service voids all express and any implied warranties for the associated TI component or service and is an unfair and deceptive business practice. TI is not responsible or liable for any such statements.

Buyer acknowledges and agrees that it is solely responsible for compliance with all legal, regulatory and safety-related requirements concerning its products, and any use of TI components in its applications, notwithstanding any applications-related information or support that may be provided by TI. Buyer represents and agrees that it has all the necessary expertise to create and implement safeguards which anticipate dangerous consequences of failures, monitor failures and their consequences, lessen the likelihood of failures that might cause harm and take appropriate remedial actions. Buyer will fully indemnify TI and its representatives against any damages arising out of the use of any TI components in safety-critical applications.

In some cases, TI components may be promoted specifically to facilitate safety-related applications. With such components, TI's goal is to help enable customers to design and create their own end-product solutions that meet applicable functional safety standards and requirements. Nonetheless, such components are subject to these terms.

No TI components are authorized for use in FDA Class III (or similar life-critical medical equipment) unless authorized officers of the parties have executed a special agreement specifically governing such use.

Only those TI components which TI has specifically designated as military grade or "enhanced plastic" are designed and intended for use in military/aerospace applications or environments. Buyer acknowledges and agrees that any military or aerospace use of TI components which have **not** been so designated is solely at the Buyer's risk, and that Buyer is solely responsible for compliance with all legal and regulatory requirements in connection with such use.

TI has specifically designated certain components as meeting ISO/TS16949 requirements, mainly for automotive use. In any case of use of non-designated products, TI will not be responsible for any failure to meet ISO/TS16949.

### Products

Audio	<a href="http://www.ti.com/audio">www.ti.com/audio</a>
Amplifiers	<a href="http://amplifier.ti.com">amplifier.ti.com</a>
Data Converters	<a href="http://dataconverter.ti.com">dataconverter.ti.com</a>
DLP® Products	<a href="http://www.dlp.com">www.dlp.com</a>
DSP	<a href="http://dsp.ti.com">dsp.ti.com</a>
Clocks and Timers	<a href="http://www.ti.com/clocks">www.ti.com/clocks</a>
Interface	<a href="http://interface.ti.com">interface.ti.com</a>
Logic	<a href="http://logic.ti.com">logic.ti.com</a>
Power Mgmt	<a href="http://power.ti.com">power.ti.com</a>
Microcontrollers	<a href="http://microcontroller.ti.com">microcontroller.ti.com</a>
RFID	<a href="http://www.ti-rfid.com">www.ti-rfid.com</a>
OMAP Applications Processors	<a href="http://www.ti.com/omap">www.ti.com/omap</a>
Wireless Connectivity	<a href="http://www.ti.com/wirelessconnectivity">www.ti.com/wirelessconnectivity</a>

### Applications

Automotive and Transportation	<a href="http://www.ti.com/automotive">www.ti.com/automotive</a>
Communications and Telecom	<a href="http://www.ti.com/communications">www.ti.com/communications</a>
Computers and Peripherals	<a href="http://www.ti.com/computers">www.ti.com/computers</a>
Consumer Electronics	<a href="http://www.ti.com/consumer-apps">www.ti.com/consumer-apps</a>
Energy and Lighting	<a href="http://www.ti.com/energy">www.ti.com/energy</a>
Industrial	<a href="http://www.ti.com/industrial">www.ti.com/industrial</a>
Medical	<a href="http://www.ti.com/medical">www.ti.com/medical</a>
Security	<a href="http://www.ti.com/security">www.ti.com/security</a>
Space, Avionics and Defense	<a href="http://www.ti.com/space-avionics-defense">www.ti.com/space-avionics-defense</a>
Video and Imaging	<a href="http://www.ti.com/video">www.ti.com/video</a>

### TI E2E Community

[e2e.ti.com](http://e2e.ti.com)

## Looking for pricing, stock, or lifecycle information?

Click below to explore more details on WIN SOURCE:

 [View LM725CN](#) on WIN SOURCE

 [Texas Instruments](#) Information

## Optimize Your Supply Chain with WIN SOURCE Solutions

-  Global Sourcing Solution
-  Obsolete Management
-  Cost Control Management
-  Shortage Management
-  Alternative Solution
-  Excess Inventory Management