



THE DATASHEET OF LM828M5



LM828 Switched Capacitor Voltage Converter

 Check for Samples: [LM828](#)

FEATURES

- Inverts Input Supply Voltage
- SOT-23 Package
- 20Ω Typical Output Impedance
- 97% Typical Conversion Efficiency at 5 mA

APPLICATIONS

- Cellular Phones
- Pagers
- PDAs
- Operational Amplifier Power Supplies
- Interface Power Supplies
- Handheld Instruments

DESCRIPTION

The LM828 CMOS charge-pump voltage converter inverts a positive voltage in the range of +1.8V to +5.5V to the corresponding negative voltage of -1.8V to -5.5V. The LM828 uses two low cost capacitors to provide up to 25 mA of output current.

The LM828 operates at 12 kHz switching frequency to reduce output resistance and voltage ripple. With an operating current of only 40 μA (operating efficiency greater than 96% with most loads), the LM828 provides ideal performance for battery powered systems. The device is in a tiny SOT-23 package.

Basic Application Circuits

Voltage Inverter

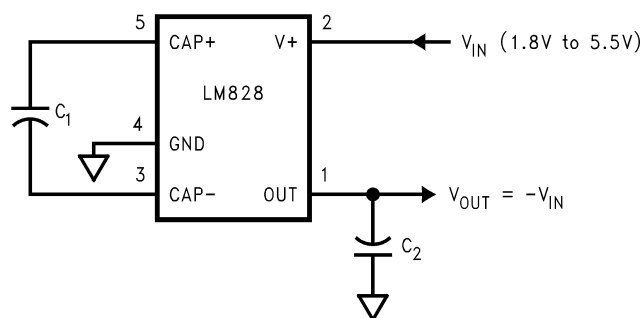

+5V to -10V Converter

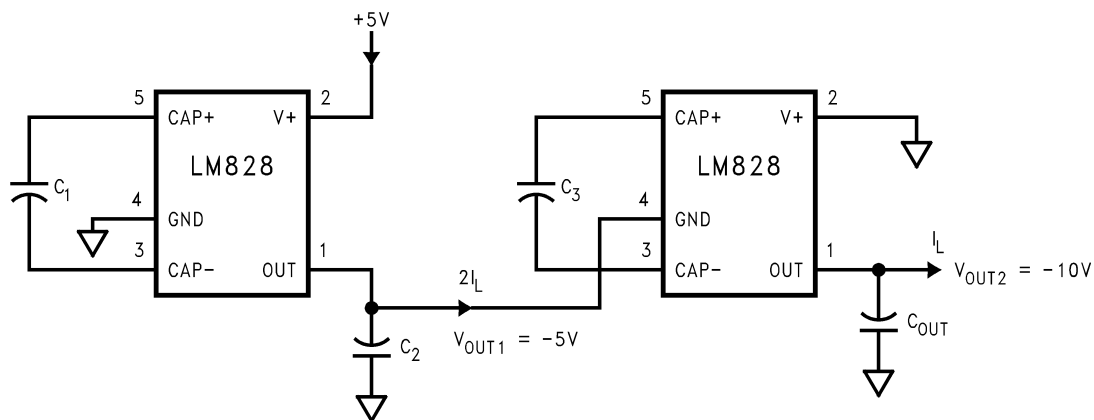

Please be aware that an important notice concerning availability, standard warranty, and use in critical applications of Texas Instruments semiconductor products and disclaimers thereto appears at the end of this data sheet.

All trademarks are the property of their respective owners.



These devices have limited built-in ESD protection. The leads should be shorted together or the device placed in conductive foam during storage or handling to prevent electrostatic damage to the MOS gates.

Absolute Maximum Ratings⁽¹⁾⁽²⁾

Supply Voltage (V+ to GND, or GND to OUT)	5.8V
V+ and OUT Continuous Output Current	50 mA
Output Short-Circuit Duration to GND ⁽³⁾	1 sec.
Continuous Power Dissipation (T _A = 25°C) ⁽⁴⁾	240 mW
T _{JMax} ⁽⁴⁾	150°C
θ _{JA} ⁽⁴⁾	300°C/W
Operating Junction Temperature Range	-40°C to 85°C
Storage Temperature Range	-65°C to +150°C
Lead Temp. (Soldering, 10 seconds)	300°C
ESD Rating ⁽⁵⁾	2kV

- (1) Absolute maximum ratings indicate limits beyond which damage to the device may occur. Electrical specifications do not apply when operating the device beyond its rated operating conditions.
- (2) If Military/Aerospace specified devices are required, please contact the Texas Instruments Sales Office/Distributors for availability and specifications.
- (3) OUT may be shorted to GND for one second without damage. However, shorting OUT to V+ may damage the device and should be avoided. Also, for temperatures above 85°C, OUT must not be shorted to GND or V+, or the device may be damaged.
- (4) The maximum allowable power dissipation is calculated by using $P_{DMax} = (T_{JMax} - T_A)/\theta_{JA}$, where T_{JMax} is the maximum junction temperature, T_A is the ambient temperature, and θ_{JA} is the junction-to-ambient thermal resistance of the package.
- (5) The human body model is a 100 pF capacitor discharged through a 1.5 kΩ resistor into each pin.

Electrical Characteristics

Limits in standard typeface are for T_J = 25°C, and limits in **boldface** type apply over the full operating temperature range.

Unless otherwise specified: V+ = 5V, C₁ = C₂ = 10 μF.⁽¹⁾

Symbol	Parameter	Condition	Min	Typ	Max	Units
V+	Supply Voltage	R _L = 10kΩ	1.8		5.5	V
I _Q	Supply Current	No Load		40	75	μA
					115	
R _{OUT}	Output Resistance ⁽²⁾	I _L = 5 mA		20	65	Ω
f _{OSC}	Oscillator Frequency ⁽³⁾	Internal	12	24	56	kHz
f _{SW}	Switching Frequency ⁽³⁾	Measured at CAP+	6	12	28	kHz
P _{EFF}	Power Efficiency	I _L = 5 mA		97		%
V _{OEFF}	Voltage Conversion Efficiency	No Load	95	99.96		%

- (1) In the test circuit, capacitors C₁ and C₂ are 10 μF, 0.3Ω maximum ESR capacitors. Capacitors with higher ESR will increase output resistance, reduce output voltage and efficiency.
- (2) Specified output resistance includes internal switch resistance and capacitor ESR. See the details in the application information.
- (3) The output switches operate at one half of the oscillator frequency, f_{OSC} = 2f_{SW}.

Test Circuit

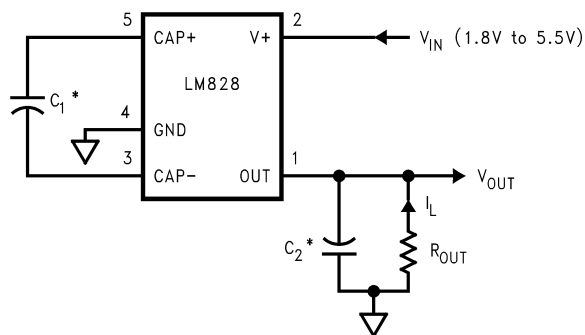

*C₁ and C₂ are 10 μF capacitors.

Figure 1. LM828 Test Circuit

Typical Performance Characteristics

(Circuit of Figure 1, V₊ = 5V unless otherwise specified)

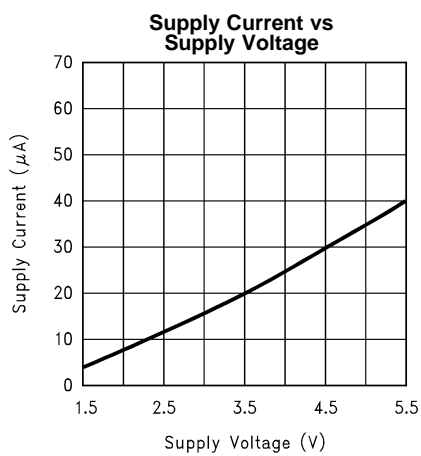

Figure 2.

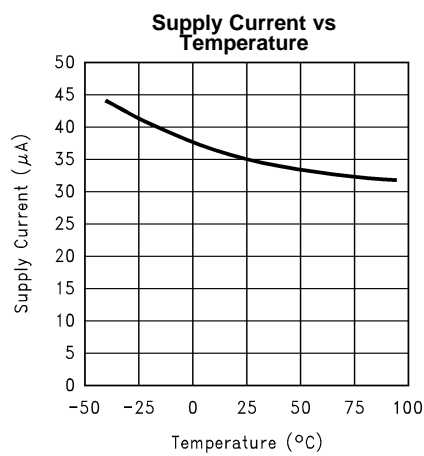

Figure 3.

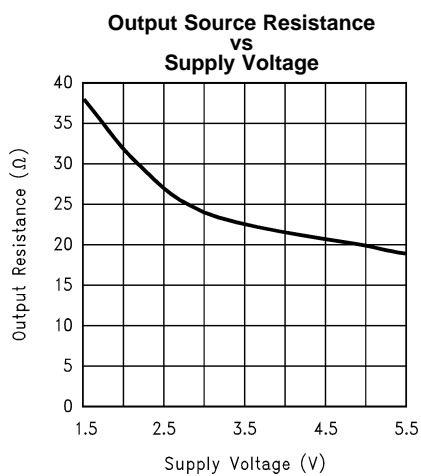

Figure 4.

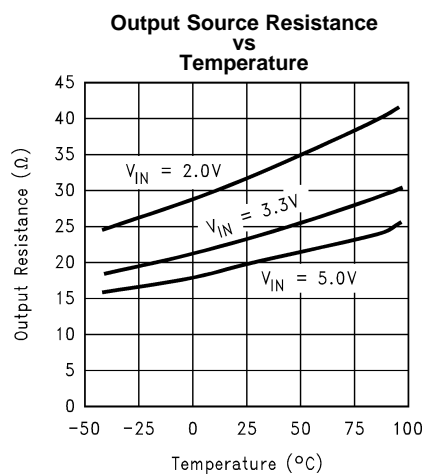

Figure 5.

Typical Performance Characteristics (continued)

(Circuit of [Figure 1](#), $V_+ = 5V$ unless otherwise specified)

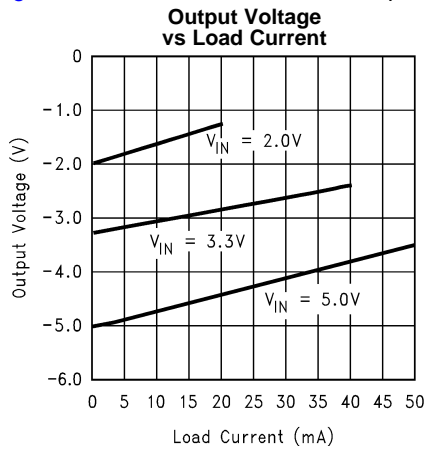

Figure 6.

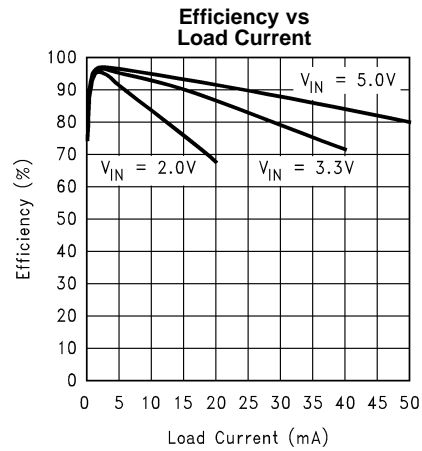

Figure 7.

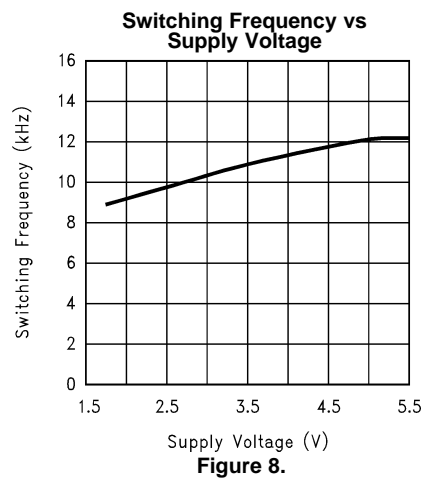

Figure 8.

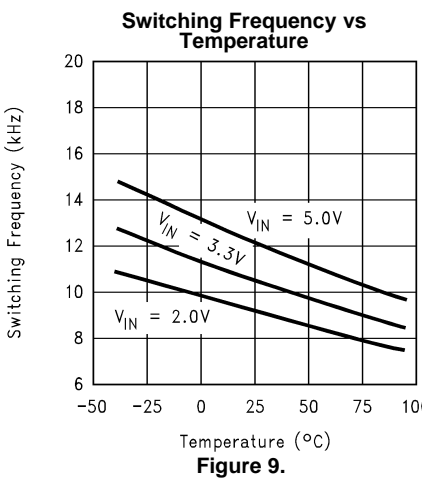

Figure 9.

CONNECTION DIAGRAMS

5-Lead SOT-23 Package (DBV)

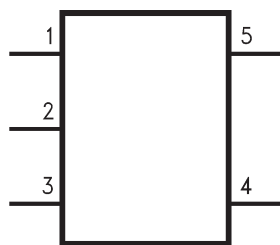

Figure 10. SOT-23 Package – Top View
See Package Number DBV0005A



Figure 11. Actual Size

Pin Functions

PIN DESCRIPTIONS

Pin	Name	Function
1	OUT	Negative voltage output.
2	V+	Power supply positive input.
3	CAP-	Connect this pin to the negative terminal of the charge-pump capacitor.
4	GND	Power supply ground input.
5	CAP+	Connect this pin to the positive terminal of the charge-pump capacitor.

Circuit Description

The LM828 contains four large CMOS switches which are switched in a sequence to invert the input supply voltage. Energy transfer and storage are provided by external capacitors. Figure 12 illustrates the voltage conversion scheme. When S_1 and S_3 are closed, C_1 charges to the supply voltage V_+ . During this time interval, switches S_2 and S_4 are open. In the second time interval, S_1 and S_3 are open; at the same time, S_2 and S_4 are closed, C_1 is charging C_2 . After a number of cycles, the voltage across C_2 will be pumped to V_+ . Since the anode of C_2 is connected to ground, the output at the cathode of C_2 equals $-(V_+)$ when there is no load current. The output voltage drop when a load is added is determined by the parasitic resistance ($R_{ds(on)}$ of the MOSFET switches and the ESR of the capacitors) and the charge transfer loss between capacitors.

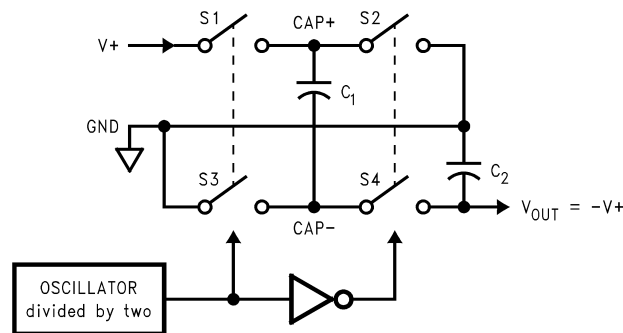

Figure 12. Voltage Inverting Principle

Application Information

SIMPLE NEGATIVE VOLTAGE CONVERTER

The main application of LM828 is to generate a negative supply voltage. The voltage inverter circuit uses only two external capacitors as shown in the Basic Application Circuits. The range of the input supply voltage is 1.8V to 5.5V.

The output characteristics of this circuit can be approximated by an ideal voltage source in series with a resistance. The voltage source equals $-(V_+)$. The output resistance, R_{out} , is a function of the ON resistance of the internal MOSFET switches, the oscillator frequency, the capacitance and the ESR of both C_1 and C_2 . Since the switching current charging and discharging C_1 is approximately twice as the output current, the effect of the ESR of the pumping capacitor C_1 will be multiplied by four in the output resistance. The output capacitor C_2 is charging and discharging at a current approximately equal to the output current, therefore, this ESR term only counts once in the output resistance. A good approximation of R_{out} is:

$$R_{OUT} \cong 2R_{SW} + \frac{2}{f_{OSC} \times C_1} + 4ESR_{C1} + ESR_{C2} \quad (1)$$

where R_{SW} is the sum of the ON resistance of the internal MOSFET switches shown in Figure 12.

High capacitance, low ESR capacitors will reduce the output resistance.

The peak-to-peak output voltage ripple is determined by the oscillator frequency, the capacitance and ESR of the output capacitor C_2 :

$$V_{\text{RIPPLE}} = \frac{I_L}{f_{\text{OSC}} \times C_2} + 2 \times I_L \times \text{ESR}_{C2} \quad (2)$$

Again, using a low ESR capacitor will result in lower ripple.

CAPACITOR SELECTION

The output resistance and ripple voltage are dependent on the capacitance and ESR values of the external capacitors. The output voltage drop is the load current times the output resistance, and the power efficiency is

$$\eta = \frac{P_{\text{OUT}}}{P_{\text{IN}}} = \frac{I_L^2 R_L}{I_L^2 R_L + I_L^2 R_{\text{OUT}} + I_Q (V+)} \quad (3)$$

Where $I_Q(V+)$ is the quiescent power loss of the IC device, and $I_L^2 R_{\text{OUT}}$ is the conversion loss associated with the switch on-resistance, the two external capacitors and their ESRs.

The selection of capacitors is based on the specifications of the dropout voltage (which equals $I_{\text{out}} R_{\text{out}}$), the output voltage ripple, and the converter efficiency. Low ESR capacitors (following table) are recommended to maximize efficiency, reduce the output voltage drop and voltage ripple.

Low ESR Capacitor Manufacturers

Manufacturer	Phone	Capacitor Type
Nichicon Corp.	(708)-843-7500	PL & PF series, through-hole aluminum electrolytic
AVX Corp.	(803)-448-9411	TPS series, surface-mount tantalum
Sprague	(207)-324-4140	593D, 594D, 595D series, surface-mount tantalum
Sanyo	(619)-661-6835	OS-CON series, through-hole aluminum electrolytic
Murata	(800)-831-9172	Ceramic chip capacitors
Taiyo Yuden	(800)-348-2496	Ceramic chip capacitors
Token	(408)-432-8020	Ceramic chip capacitors

Other Applications

PARALLELING DEVICES

Any number of LM828s can be paralleled to reduce the output resistance. Each device must have its own pumping capacitor C_1 , while only one output capacitor C_{out} is needed as shown in [Figure 13](#). The composite output resistance is:

$$R_{\text{OUT}} = \frac{R_{\text{OUT}} \text{ of each LM828}}{\text{Number of Devices}} \quad (4)$$

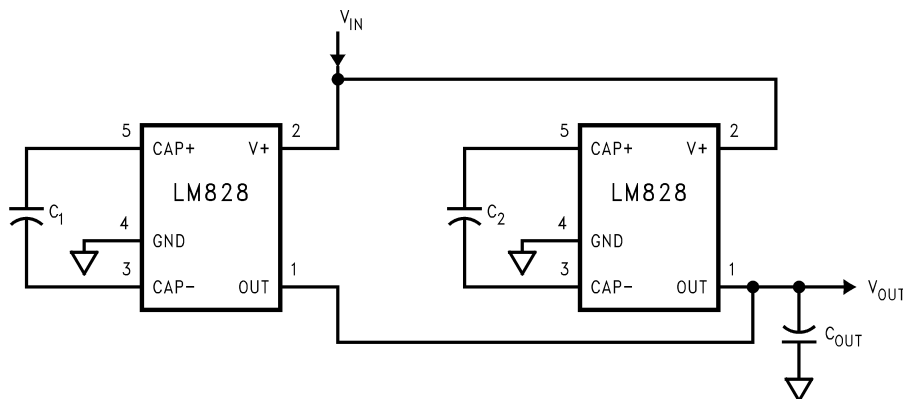

Figure 13. Lowering Output Resistance by Paralleling Devices

CASCADING DEVICES

Cascading the LM828s is an easy way to produce a greater negative voltage (e.g. A two-stage cascade circuit is shown in Figure 14).

If n is the integer representing the number of devices cascaded, the unloaded output voltage V_{out} is $(-nV_{in})$. The effective output resistance is equal to the weighted sum of each individual device:

$$R_{out} = nR_{out_1} + n/2 R_{out_2} + \dots + R_{out_n} \quad (5)$$

This can be seen by first assuming that each device is 100 percent efficient. Since the output voltage is different on each device the output current is as well. Each cascaded device sees less current at the output than the previous so the R_{OUT} voltage drop is lower in each device added. Note that, the number of n is practically limited since the increasing of n significantly reduces the efficiency, and increases the output resistance and output voltage ripple.

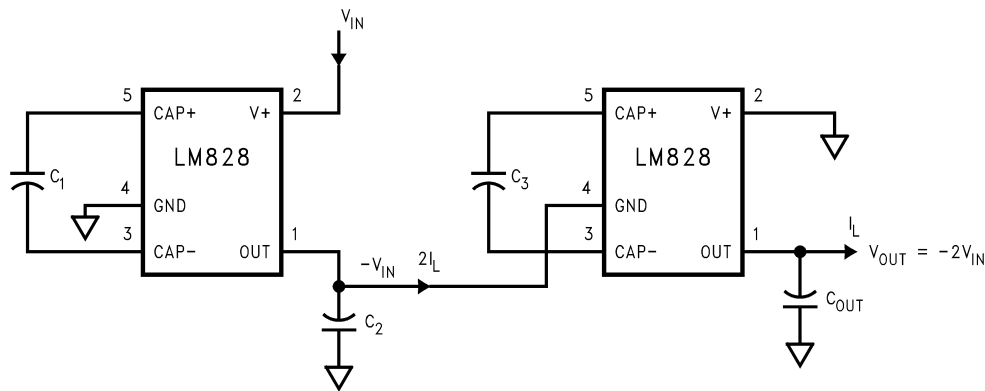

Figure 14. Increasing Output Voltage by Cascading Devices

COMBINED DOUBLER AND INVERTER

In Figure 15, the LM828 is used to provide a positive voltage doubler and a negative voltage converter. Note that the total current drawn from the two outputs should not exceed 40 mA.

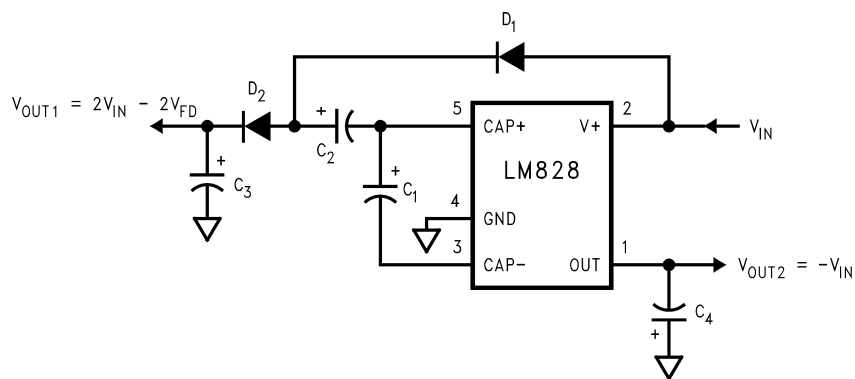

Figure 15. Combined Voltage Doubler and Inverter

REGULATING V_{OUT}

It is possible to regulate the negative output of the LM828 by use of a low dropout regulator (such as the LP2980). The whole converter is depicted in Figure 16. This converter can give a regulated output from $-1.8V$ to $-5.5V$ by choosing the proper resistor ratio:

$$V_{out} = V_{ref} (1 + R_1/R_2) \quad (6)$$

$$\text{where, } V_{ref} = 1.23V \quad (7)$$

Note that the following conditions must be satisfied simultaneously for worst case design:

$$V_{in_min} > V_{out_min} + V_{drop_max} \text{ (LP2980)} \quad (8)$$

$$+ I_{out_max} \times R_{out_max} \text{ (LM828)} \quad (9)$$

$$V_{in_max} < V_{out_max} + V_{drop_min} \text{ (LP2980)} \quad (10)$$

$$+ I_{out_min} \times R_{out_min} \text{ (LM828)} \quad (11)$$

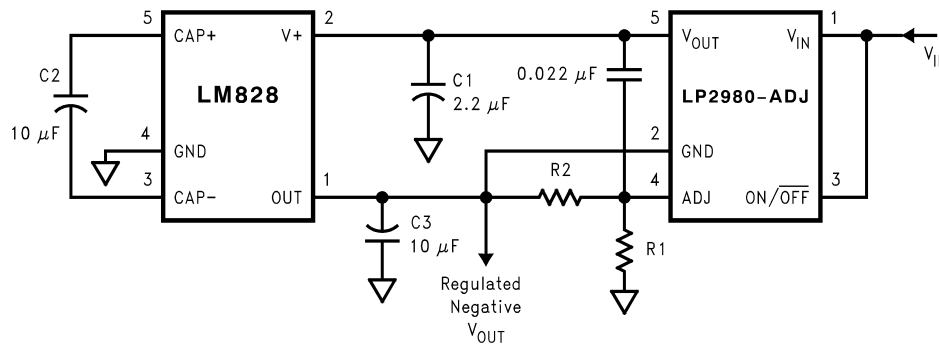



Figure 16. Combining LM828 with LP2980 to Make a Negative Adjustable Regulator

REVISION HISTORY

Changes from Revision C (May 2013) to Revision D	Page
<hr/> <ul style="list-style-type: none">• Changed layout of National Data Sheet to TI format	<hr/> 8

PACKAGING INFORMATION

Orderable Device	Status (1)	Package Type	Package Drawing	Pins	Package Qty	Eco Plan (2)	Lead/Ball Finish (6)	MSL Peak Temp (3)	Op Temp (°C)	Device Marking (4/5)	Samples
LM828M5	NRND	SOT-23	DBV	5	1000	TBD	Call TI	Call TI		S08A	
LM828M5/NOPB	ACTIVE	SOT-23	DBV	5	1000	Green (RoHS & no Sb/Br)	CU SN	Level-1-260C-UNLIM	-40 to 85	S08A	
LM828M5X	NRND	SOT-23	DBV	5	3000	TBD	Call TI	Call TI		S08A	
LM828M5X/NOPB	ACTIVE	SOT-23	DBV	5	3000	Green (RoHS & no Sb/Br)	CU SN	Level-1-260C-UNLIM	-40 to 85	S08A	

(1) The marketing status values are defined as follows:

ACTIVE: Product device recommended for new designs.

LIFEBUY: TI has announced that the device will be discontinued, and a lifetime-buy period is in effect.

NRND: Not recommended for new designs. Device is in production to support existing customers, but TI does not recommend using this part in a new design.

PREVIEW: Device has been announced but is not in production. Samples may or may not be available.

OBSELETE: TI has discontinued the production of the device.

(2) **RoHS:** TI defines "RoHS" to mean semiconductor products that are compliant with the current EU RoHS requirements for all 10 RoHS substances, including the requirement that RoHS substance do not exceed 0.1% by weight in homogeneous materials. Where designed to be soldered at high temperatures, "RoHS" products are suitable for use in specified lead-free processes. TI may reference these types of products as "Pb-Free".

RoHS Exempt: TI defines "RoHS Exempt" to mean products that contain lead but are compliant with EU RoHS pursuant to a specific EU RoHS exemption.

Green: TI defines "Green" to mean the content of Chlorine (Cl) and Bromine (Br) based flame retardants meet JS709B low halogen requirements of <=1000ppm threshold. Antimony trioxide based flame retardants must also meet the <=1000ppm threshold requirement.

(3) MSL, Peak Temp. - The Moisture Sensitivity Level rating according to the JEDEC industry standard classifications, and peak solder temperature.

(4) There may be additional marking, which relates to the logo, the lot trace code information, or the environmental category on the device.

(5) Multiple Device Markings will be inside parentheses. Only one Device Marking contained in parentheses and separated by a "~" will appear on a device. If a line is indented then it is a continuation of the previous line and the two combined represent the entire Device Marking for that device.

(6) Lead/Ball Finish - Orderable Devices may have multiple material finish options. Finish options are separated by a vertical ruled line. Lead/Ball Finish values may wrap to two lines if the finish value exceeds the maximum column width.

Important Information and Disclaimer:The information provided on this page represents TI's knowledge and belief as of the date that it is provided. TI bases its knowledge and belief on information provided by third parties, and makes no representation or warranty as to the accuracy of such information. Efforts are underway to better integrate information from third parties. TI has taken and continues to take reasonable steps to provide representative and accurate information but may not have conducted destructive testing or chemical analysis on incoming materials and chemicals. TI and TI suppliers consider certain information to be proprietary, and thus CAS numbers and other limited information may not be available for release.

In no event shall TI's liability arising out of such information exceed the total purchase price of the TI part(s) at issue in this document sold by TI to Customer on an annual basis.

TAPE AND REEL INFORMATION

QUADRANT ASSIGNMENTS FOR PIN 1 ORIENTATION IN TAPE

*All dimensions are nominal

Device	Package Type	Package Drawing	Pins	SPQ	Reel Diameter (mm)	Reel Width W1 (mm)	A0 (mm)	B0 (mm)	K0 (mm)	P1 (mm)	W (mm)	Pin1 Quadrant
LM828M5	SOT-23	DBV	5	1000	178.0	8.4	3.2	3.2	1.4	4.0	8.0	Q2
LM828M5/NOPB	SOT-23	DBV	5	1000	178.0	8.4	3.2	3.2	1.4	4.0	8.0	Q2
LM828M5X	SOT-23	DBV	5	3000	178.0	8.4	3.2	3.2	1.4	4.0	8.0	Q2
LM828M5X/NOPB	SOT-23	DBV	5	3000	178.0	8.4	3.2	3.2	1.4	4.0	8.0	Q2

TAPE AND REEL BOX DIMENSIONS

*All dimensions are nominal

Device	Package Type	Package Drawing	Pins	SPQ	Length (mm)	Width (mm)	Height (mm)
LM828M5	SOT-23	DBV	5	1000	210.0	185.0	35.0
LM828M5/NOPB	SOT-23	DBV	5	1000	210.0	185.0	35.0
LM828M5X	SOT-23	DBV	5	3000	210.0	185.0	35.0
LM828M5X/NOPB	SOT-23	DBV	5	3000	210.0	185.0	35.0

DBV0005A



PACKAGE OUTLINE

SOT-23 - 1.45 mm max height

SMALL OUTLINE TRANSISTOR

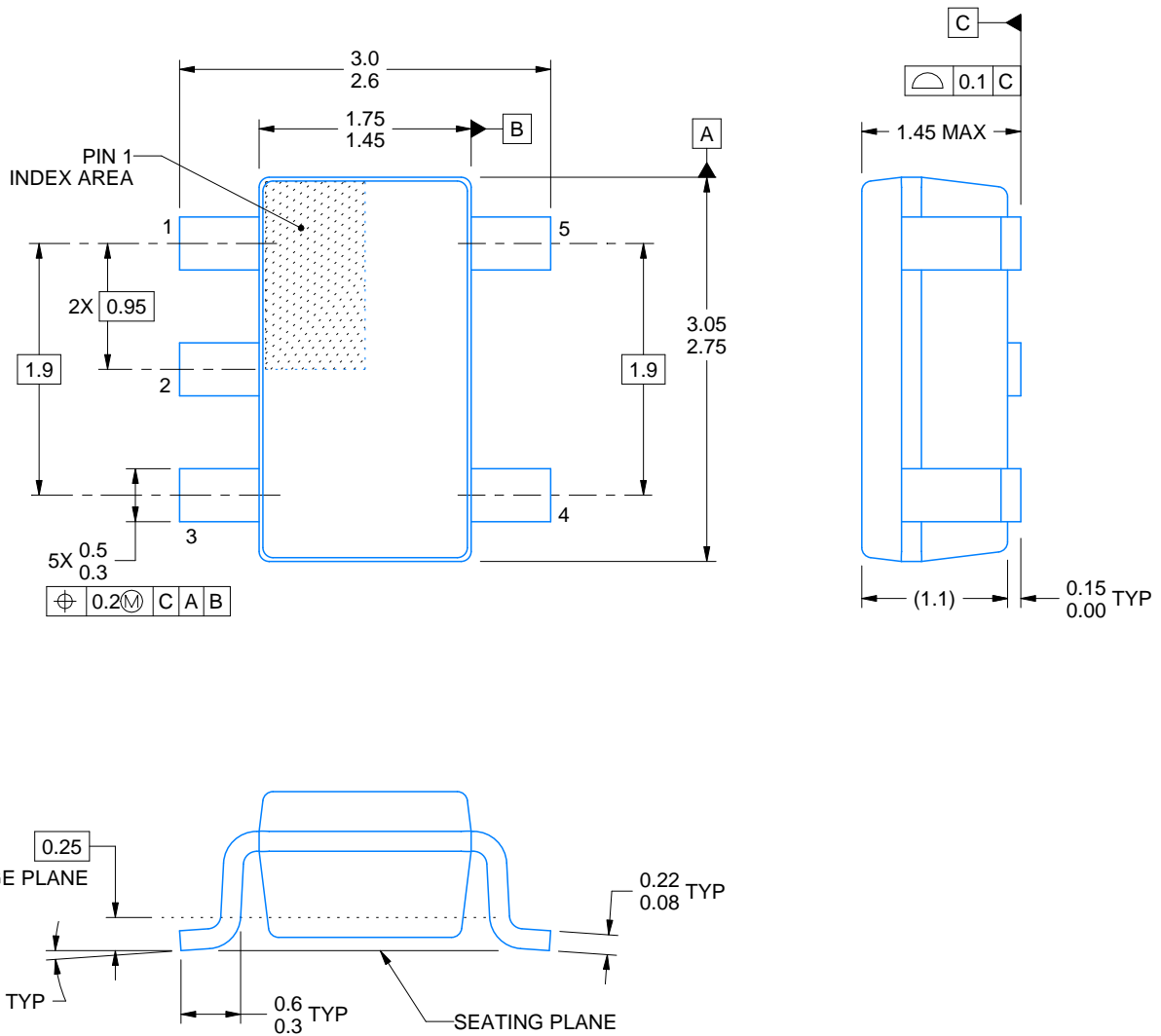

4214839/D 11/2018

NOTES:

1. All linear dimensions are in millimeters. Any dimensions in parenthesis are for reference only. Dimensioning and tolerancing per ASME Y14.5M.
2. This drawing is subject to change without notice.
3. Reference JEDEC MO-178.
4. Body dimensions do not include mold flash, protrusions, or gate burrs. Mold flash, protrusions, or gate burrs shall not exceed 0.15 mm per side.

EXAMPLE BOARD LAYOUT

DBV0005A

SOT-23 - 1.45 mm max height

SMALL OUTLINE TRANSISTOR



LAND PATTERN EXAMPLE
EXPOSED METAL SHOWN
SCALE:15X

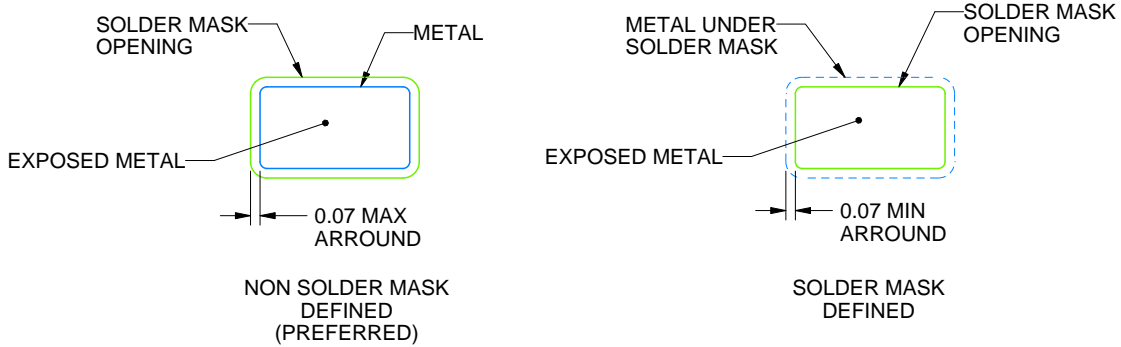

SOLDER MASK DETAILS

4214839/D 11/2018

NOTES: (continued)

- 5. Publication IPC-7351 may have alternate designs.
- 6. Solder mask tolerances between and around signal pads can vary based on board fabrication site.

EXAMPLE STENCIL DESIGN

DBV0005A

SOT-23 - 1.45 mm max height

SMALL OUTLINE TRANSISTOR



SOLDER PASTE EXAMPLE
BASED ON 0.125 mm THICK STENCIL
SCALE:15X

4214839/D 11/2018

NOTES: (continued)

7. Laser cutting apertures with trapezoidal walls and rounded corners may offer better paste release. IPC-7525 may have alternate design recommendations.
8. Board assembly site may have different recommendations for stencil design.

IMPORTANT NOTICE AND DISCLAIMER

TI PROVIDES TECHNICAL AND RELIABILITY DATA (INCLUDING DATASHEETS), DESIGN RESOURCES (INCLUDING REFERENCE DESIGNS), APPLICATION OR OTHER DESIGN ADVICE, WEB TOOLS, SAFETY INFORMATION, AND OTHER RESOURCES "AS IS" AND WITH ALL FAULTS, AND DISCLAIMS ALL WARRANTIES, EXPRESS AND IMPLIED, INCLUDING WITHOUT LIMITATION ANY IMPLIED WARRANTIES OF MERCHANTABILITY, FITNESS FOR A PARTICULAR PURPOSE OR NON-INFRINGEMENT OF THIRD PARTY INTELLECTUAL PROPERTY RIGHTS.

These resources are intended for skilled developers designing with TI products. You are solely responsible for (1) selecting the appropriate TI products for your application, (2) designing, validating and testing your application, and (3) ensuring your application meets applicable standards, and any other safety, security, or other requirements. These resources are subject to change without notice. TI grants you permission to use these resources only for development of an application that uses the TI products described in the resource. Other reproduction and display of these resources is prohibited. No license is granted to any other TI intellectual property right or to any third party intellectual property right. TI disclaims responsibility for, and you will fully indemnify TI and its representatives against, any claims, damages, costs, losses, and liabilities arising out of your use of these resources.

TI's products are provided subject to TI's Terms of Sale (www.ti.com/legal/termsofsale.html) or other applicable terms available either on ti.com or provided in conjunction with such TI products. TI's provision of these resources does not expand or otherwise alter TI's applicable warranties or warranty disclaimers for TI products.

Mailing Address: Texas Instruments, Post Office Box 655303, Dallas, Texas 75265
Copyright © 2019, Texas Instruments Incorporated

Looking for pricing, stock, or lifecycle information?

Click below to explore more details on WIN SOURCE:

 [View LM828M5 on WIN SOURCE](#)

 [Texas Instruments](#) Information

Optimize Your Supply Chain with WIN SOURCE Solutions

-  Global Sourcing Solution
-  Obsolete Management
-  Cost Control Management
-  Shortage Management
-  Alternative Solution
-  Excess Inventory Management