



# THE DATASHEET OF LM9011MX



## LM9011 Electronic Ignition Interface

Check for Samples: [LM9011](#)

### FEATURES

- **Single 5V Supply Operation**
- **VR Sensor Interface with Dynamic Hysteresis**
- **Four Channel Electronic Timing Spark Driver with Output Diagnostics**
- **Electronic Timing Interface Spark Driver Output Voltage from 5V to 16V**
- **One Non-Inverting Voltage Comparator with Hysteresis**
- **Three Inverting Voltage Comparators with Hysteresis**

### DESCRIPTION

The LM9011 is an interface circuit which integrates the timing detection and logic control functions required for an automotive electronic ignition system into one device.

A VRS interface is provided for crankshaft position information via a toothed-wheel.

Four voltage comparators are provided for hardware diagnostics.

An electronic timing interface with output fault diagnostics is provided to enable a micro-processor to drive an external four channel ignition spark circuit.

The LM9011 is fully specified over the automotive temperature range of  $-40^{\circ}\text{C}$  to  $+125^{\circ}\text{C}$ , and is available in a 28 pin Small Outline surface mount package.

### Connection Diagram

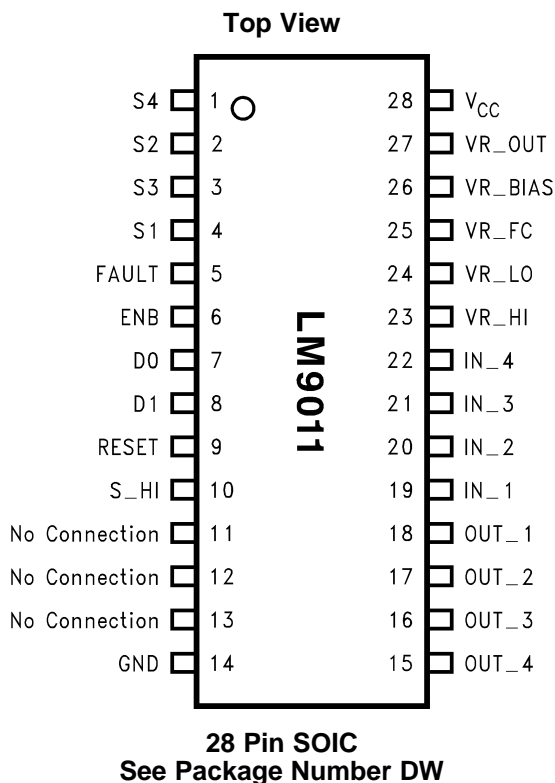

Please be aware that an important notice concerning availability, standard warranty, and use in critical applications of Texas Instruments semiconductor products and disclaimers thereto appears at the end of this data sheet.

All trademarks are the property of their respective owners.



These devices have limited built-in ESD protection. The leads should be shorted together or the device placed in conductive foam during storage or handling to prevent electrostatic damage to the MOS gates.

### Absolute Maximum Ratings<sup>(1)</sup>

Voltage	-0.3V to +7.0V
S_HI Voltage	-0.3V to 26.5V
VR_HI and VR_LO Inputs	+/-3mA
Comparator Inputs	-0.3V to +7.0V
Timing Interface Inputs	-0.3V to +7.0V
ESD Susceptibility <sup>(2)</sup>	+/-2000V
Maximum Junction Temperature	150°C
Storage Temperature Range	-65°C to +150°C
Lead Soldering Information:	
Vapor Phase (60 Seconds)	215°C
Infrared (15 Seconds)	220°C

- (1) Absolute Maximum Ratings indicate the limits beyond which damage may occur.  
 (2) ESD Ratings is with Human Body Model: 100pF discharged through a 1500Ω resistor.

### Operating Ratings<sup>(1)</sup>

V <sub>CC</sub> Voltage	4.75V to 5.25V
S_HI Voltage	V <sub>CC</sub> to 26V
Sx Outputs	-0.3V to S_HI +0.3V
Comparator Inputs VR_HI and VR_LO Inputs	-0.3V to V <sub>CC</sub> +0.3V +/-2.75mA
Timing Interface Inputs	-0.3V to V <sub>CC</sub> +0.3V
Thermal Resistances (DW):	
Junction to Case (θ <sub>J-C</sub> )	15°C/W
Junction to Ambient (θ <sub>J-A</sub> )	69°C/W

- (1) Operating ratings indicate conditions for which the device is intended to be functional, but may not meet the ensured specific performance limits. For ensured specifications and conditions, see the Electrical Characteristics.

## DC Electrical Characteristics

The following specifications apply for  $V_{CC} = 5V$ ,  $V_{RESET} = V_{CC}$ ,  $V_{S\_HI} = V_{CC}$ ,  $-40^{\circ}C \leq T_A \leq +125^{\circ}C$ , [Typical Application Circuit](#), [Figure 24](#), unless otherwise specified.

Symbol	Parameter	Conditions	Minimum	Maximum	Units
$I_{CC}$	Supply Current	RESET, IN_4 = $V_{CC}$		25	mA
		ENB, D0, D1, IN_1, IN_2, IN_3 = 0V			
		VR_HI = +12.5 $\mu$ A			
		VR_LO = -12.5 $\mu$ A			
<b>Comparators</b>					
$V_{TH1}$	Input Threshold	$V_{IN\_1}$ Decreasing from $V_{CC}$ to 0V until $V_{OUT\_1} > V_{CC}/2$	$V_{CC} \times 0.435$	$V_{CC} \times 0.485$	V
$V_{TH2}$	Input Threshold	$V_{IN\_2}$ Decreasing from $V_{CC}$ to 0V until $V_{OUT\_2} > V_{CC}/2$	$V_{CC} \times 0.435$	$V_{CC} \times 0.485$	V
$V_{TH3}$	Input Threshold	$V_{IN\_3}$ Decreasing from $V_{CC}$ to 0V until $V_{OUT\_3} > V_{CC}/2$	$V_{CC} \times 0.40$	$V_{CC} \times 0.45$	V
$V_{TH4}$	Input Threshold	$V_{IN\_4}$ Decreasing from $V_{CC}$ to 0V until $V_{OUT\_4} < V_{CC}/2$	$V_{CC} \times 0.45$	$V_{CC} \times 0.50$	V
$V_{HYST}$	Input Hysteresis	All Comparators	150	400	mV
$I_{BIAS}$	Input Bias Current	IN_1, IN_2, IN_3 = 0V $\leq V_{IN} \leq V_{CC}$ IN_4 = 0V $\leq V_{IN\_4} \leq V_{CC}-1V$		750	$\mu$ A
$V_{OH}$	Output High Voltage	$I_{LOAD} = -100\mu A$	$V_{CC} - 1$		V
$V_{OL}$	Output Low Voltage	$I_{LOAD} = +100\mu A$		750	mV
<b>VR Sensor Interface</b>					
$V_{OH}$	Output High Voltage	$I_{LOAD} = -15\mu A$ VR_HI = -1mA, VR_LO = +1mA	$V_{CC} - 1$		V
$V_{OL}$	Output Low Voltage	Load = +15 $\mu$ A VR_HI = +1mA, VR_LO = -1mA		750	mV
$I_{DIFF(MIN)}$	Minimum Detect Differential Input Current <sup>(1)</sup>	$-40^{\circ}C \leq T_A \leq +25^{\circ}C$	0.5	3.0	$\mu$ A Pk-Pk
		$T_A = +85^{\circ}C$ <sup>(1)</sup>	0.6	3.5	$\mu$ A Pk-Pk
		$T_A = +125^{\circ}C$	1.0	5.0	$\mu$ A Pk-Pk
$I_{HYS1}$	Input Hysteresis <sup>(2)</sup>	$I_{DIFF} = 1mA$ pk-pk	75	250	$\mu$ A Pk
$I_{HYS2}$	Input Hysteresis <sup>(2)</sup>	$I_{DIFF} = 2.5mA$ pk-pk	185	625	$\mu$ A Pk
<b>Electronic Timing Interface</b>					
$V_{IH}$	Input Logic 1 D0, D1, ENB, RESET		$V_{CC} \times 0.7$		V
$V_{IL}$	Input Logic 0 D0, D1, ENB, RESET			$V_{CC} \times 0.3$	V
$I_{IH}$	Input High Current Inputs D0, D1, RESET	$V_{IN} = V_{CC}$		10	$\mu$ A
$I_{IH}$	Input High Current Input ENB	$V_{IN} = V_{CC}$		125	$\mu$ A
$I_{IL}$	Input Low Current Inputs D0, D1, ENB	$V_{IN} = 0V$		-10	$\mu$ A
$I_{IL}$	Input Low Current Input RESET	$V_{IN} = 0V$		-125	$\mu$ A
$V_{OH}$	Output High Voltage Outputs S1, S2, S3, S4	$I_{LOAD} = -10mA$ , $V_{S\_HI} = 5V$	3.75		V
$V_{OL}$	Output Low Voltage Outputs S1, S2, S3, S4	$I_{LOAD} = 1mA$ , $V_{S\_HI} = 5V$		300	mV
$V_{OH}$	Output High Voltage Outputs S1, S2, S3, S4	$I_{LOAD} = -10mA$ , $V_{S\_HI} = 16V$	14		V
$V_{OL}$	Output Low Voltage Outputs S1, S2, S3, S4	$I_{LOAD} = 1mA$ , $V_{S\_HI} = 16V$		450	mV
$V_{OH}$	Output High Voltage Outputs S1, S2, S3, S4	$I_{LOAD} = -10mA$ , $V_{S\_HI} = 26V$	22		V

(1) Minimum Detect Current is not production tested at +85C. Specifications are ensured through device characterization and Test Limits at 25°C and 125°C.

(2) Tested per VR Sensor Interface test circuit. See [Figure 17](#) and [Figure 18](#).

### DC Electrical Characteristics (continued)

The following specifications apply for  $V_{CC} = 5V$ ,  $V_{RESET} = V_{CC}$ ,  $V_{S\_HI} = V_{CC}$ ,  $-40^{\circ}C \leq T_A \leq +125^{\circ}C$ , [Typical Application Circuit](#), [Figure 24](#), unless otherwise specified.

Symbol	Parameter	Conditions	Minimum	Maximum	Units
$V_{OL}$	Output Low Voltage Outputs S1, S2, S3, S4	$I_{LOAD} = 1mA$ , $V_{S\_HI} = 26V$		600	mV
$V_{OH}$	FAULT Pin Output High Voltage	$I_{FAULT} = -100\mu A$ , no fault	$V_{CC} - 1$		V
$V_{OL}$	FAULT Pin Output Low Voltage	$I_{FAULT} = 100\mu A$ , any fault		750	mV
$V_{FAULT}$	Fault Treshold Voltage Outputs S1, S2, S3, S4	Sx Output Short Fault	$V_{CC} \times 0.2$	$V_{CC} \times 0.5$	V
$I_{FOL}$	Tri-State Output Current Outputs S1, S2, S3, S4	$V_{RESET} = 0V$ , $V_{S\_HI} = 5V$ $R_{LOAD} = 10K\Omega$	-12	-50	$\mu A$

## AC Electrical Characteristics

The following specifications apply for  $V_{CC} = 5V$ ,  $V_{S\_HI} = V_{CC}$ ,  $V_{RESET} = V_{CC}$ ,  $-40^{\circ}C \leq T_A \leq +125^{\circ}C$ . The AC Timing Characteristics are not production tested. Minimum and Maximum limits are ensured by device characterization.

Symbol	Parameter	Conditions	Minimum	Maximum	Units
<b>Comparators</b>					
$T_{RISE}$	Output Rise Time	10% to 90%, $C_{LOAD} = 25pF$		5	$\mu s$
$T_{FALL}$	Output Fall Time	90% to 10%, $C_{LOAD} = 25pF$		5	$\mu s$
<b>VR Sensor Interface<sup>(1)</sup></b>					
$T_{RISE}$	Output Rise Time	10% to 90%, $C_{LOAD} = 100pF$ , $R_{LOAD} = 100K\Omega$		10	$\mu s$
$T_{FALL}$	Output Fall Time	90% to 10%, $C_{LOAD} = 100pF$ , $R_{LOAD} = 100k\Omega$		5	$\mu s$
$T_{DELAY}$	Zero Crossing Delay Time <sup>(2)</sup>	$I_{DIFF} = 5\mu A$ pk-pk, $F_{VRS} = 200Hz$		1	ms
		$I_{DIFF} = 50\mu A$ pk-pk, $F_{VRS} = 2.5KHz$		10	$\mu s$
$F_{MAX}$	Maximum VRS Frequency	$C_{LOAD} = 100pF$ , $R_{LOAD} = 100K\Omega$ , $I_{DIFF} = 5\mu A$ pk-pk		50	KHz
<b>Electronic Timing Interface</b>					
$T_{RISE1}$	Sx Output Rise Time	Sx Rises 10% to 90%			
		$C_{LOAD} = 6.8nF$ , $R_{LOAD} = 10K\Omega$		5	$\mu s$
		$C_{LOAD} = 12.7nF$ , $R_{LOAD} = 10K\Omega$		8	$\mu s$
$T_{FALL1}$	Sx Output Fall Time	Sx Falls 90% to 10%			
		$C_{LOAD} = 6.8nF$ , $R_{LOAD} = 10K\Omega$		15	$\mu s$
		$C_{LOAD} = 12.7nF$ , $R_{LOAD} = 10K\Omega$		25	$\mu s$
$T_{SETUP}$	SetupTime <sup>(3)(4)(5)</sup>		1		$\mu s$
$T_{HOLD}$	Hold Time		0.5		$\mu s$
$T_{DF1}$	Fault Delay Time	Sx Output Short to Ground Fault From ENB = 1 to FAULT $\leq 10\%$			
		$C_{FAULT} = 25pF$		2	$\mu s$
$T_{DF2}$	Fault Delay Time	Sx Output Short to Battery Fault From ENB = 0 to FAULT $\leq 10\%$			
		$C_{FAULT} = 25pF$		2	$\mu s$
$T_{TRI}$	Tri-State Delay Time	From RESET = 0 to All Sx Outputs Off		2	$\mu s$
$T_{RISE2}$	Fault Pin Rise Time	10% to 90%, $C_{FAULT} = 25pF$		5	$\mu s$
$T_{FF(OFF)}$	False Fault Time	From ENB = 0 to FAULT $\geq 90\%$			
		$C_{FAULT} = 25pF$			
		$C_{LOAD} = 6.8nF$ , $R_{LOAD} = 10K\Omega$		25	$\mu s$
$T_{FF(ON)}$	False Fault Time	From ENB = 1 to FAULT $\geq 90\%$			
		$C_{FAULT} = 25pF$			
$T_{UDF}$	Undefined Fault Time	From ENB = 0 for 8uSec, to Valid FAULT			
		$C_{LOAD} = 6.8nF$ , $R_{LOAD} = 10K\Omega$		20	$\mu s$
		$C_{LOAD} = 12.7nF$ , $R_{LOAD} = 10K\Omega$		25	$\mu s$

(1) Tested per VR Sensor Interface test circuit. See [Figure 17](#) and [Figure 18](#).

(2) VR Sensor Interface Tdelay, measured from VR input sine wave zero-crossing to VR\_OUT going high. See [Figure 18](#).

(3) Electronic Timing Interface Tsetup, minimum time between  $V_{CC} > 4.75V$  and RESET = 1.

(4) Electronic Timing Interface Tsetup, minimum time between RESET = 1 and D0 = 1.

(5) Electronic Timing Interface Tsetup, minimum time between D0 / D1 = valid and ENB = 1.

### Typical Performance Characteristics

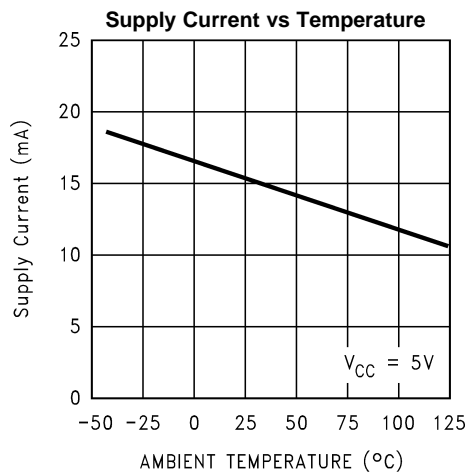

Figure 1.

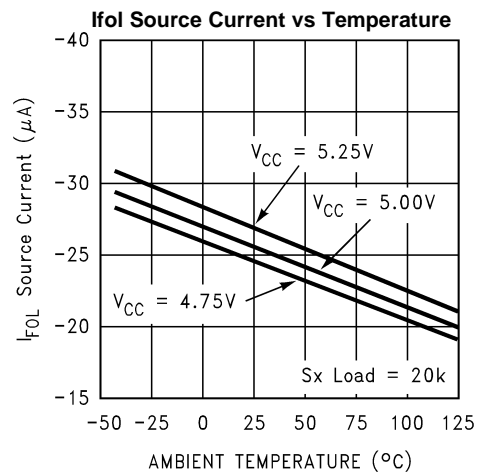

Figure 2.

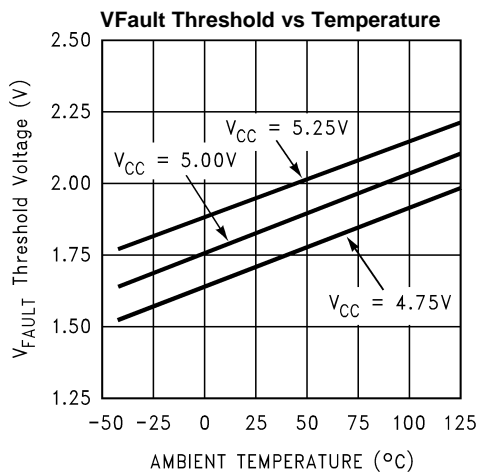

Figure 3.

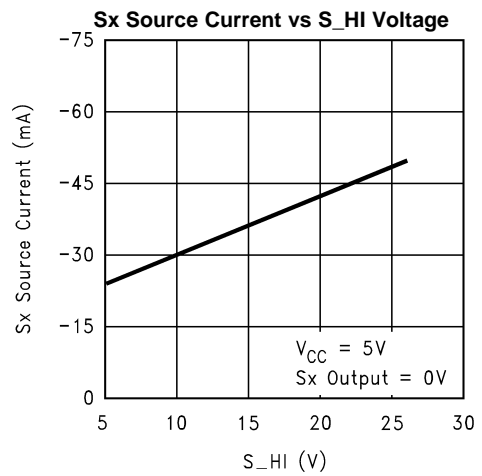

Figure 4.

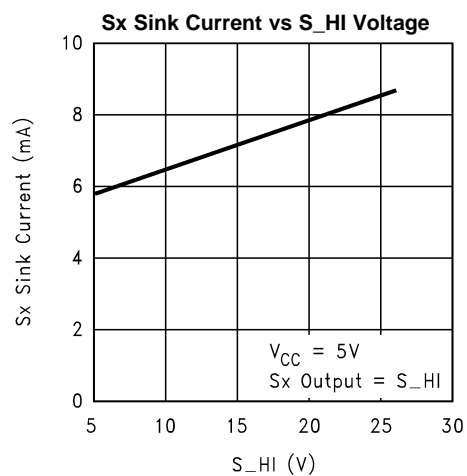

Figure 5.

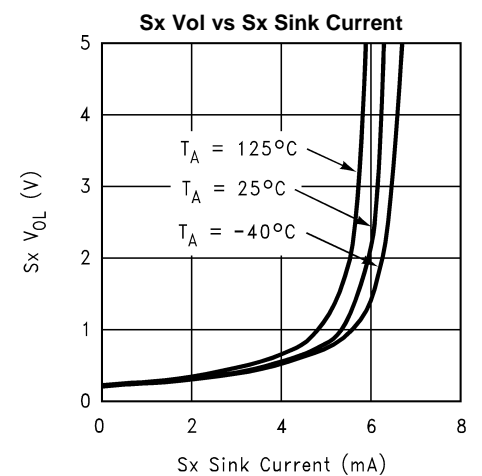

Figure 6.

Typical Performance Characteristics (continued)

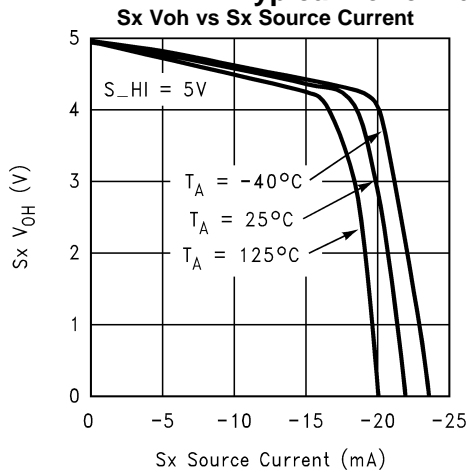

Figure 7.

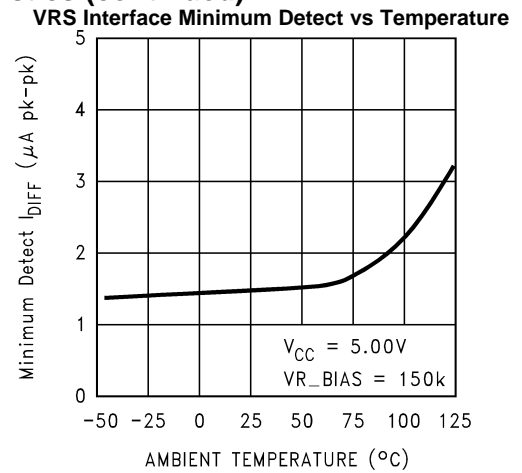

Figure 8.

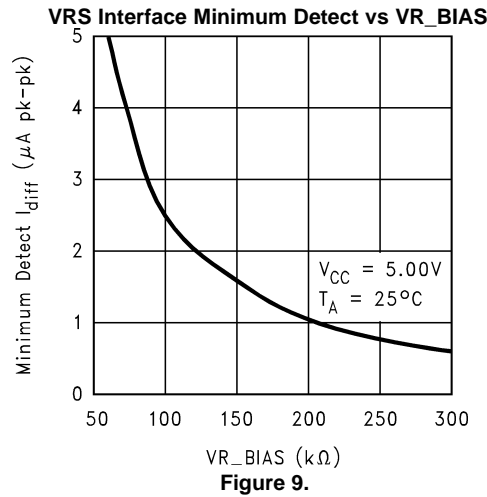
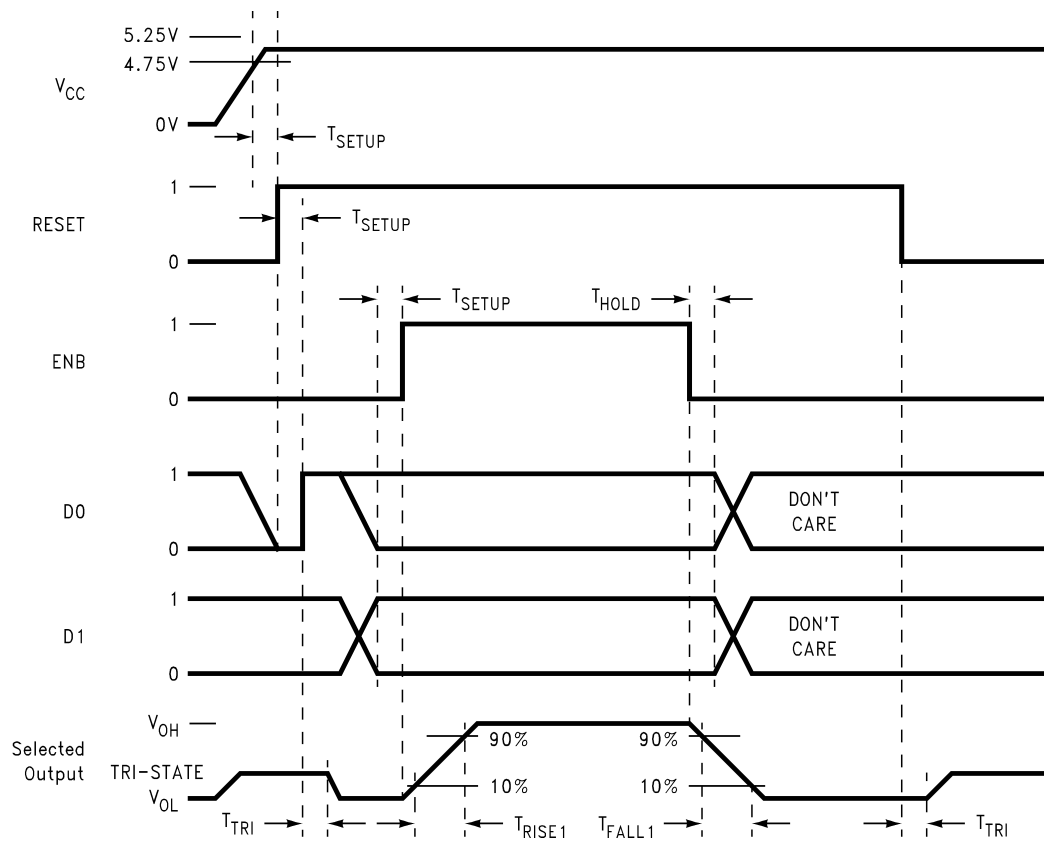

Figure 9.

## TEST CIRCUIT DIAGRAMS

### Timing Diagrams



**Figure 10. Electronic Timing Interface Timing Diagram**

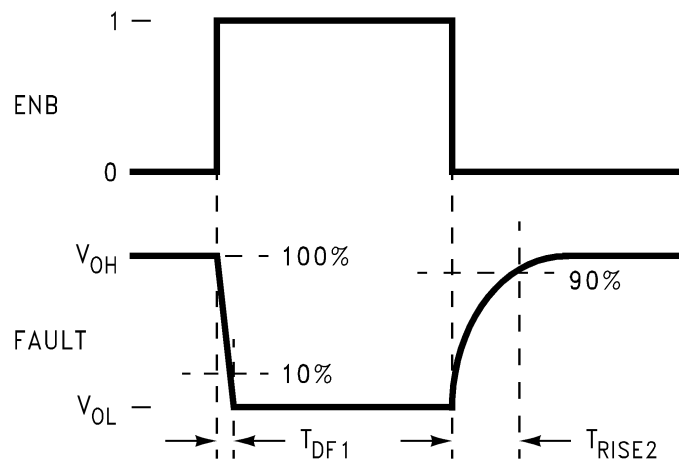

**Figure 11. Fault Pin Timing During  $S_x$  Shorted to Ground**

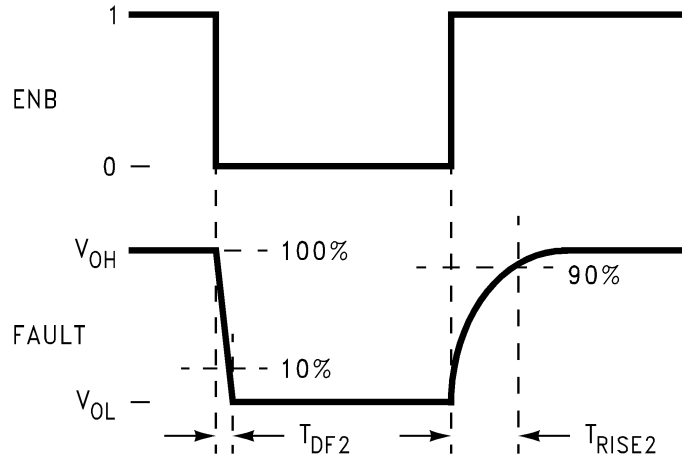

Figure 12. Fault Pin Timing During Sx Shorted to Battery

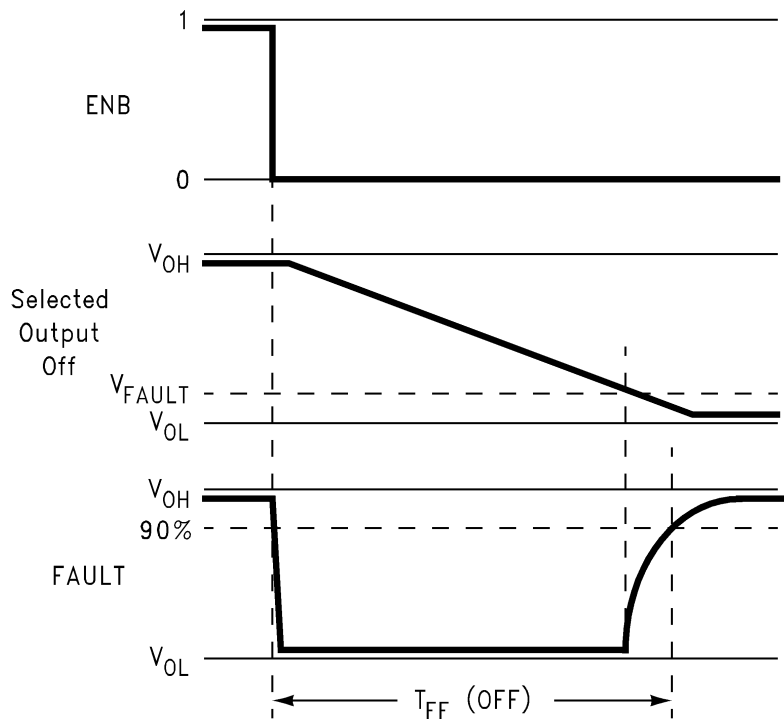
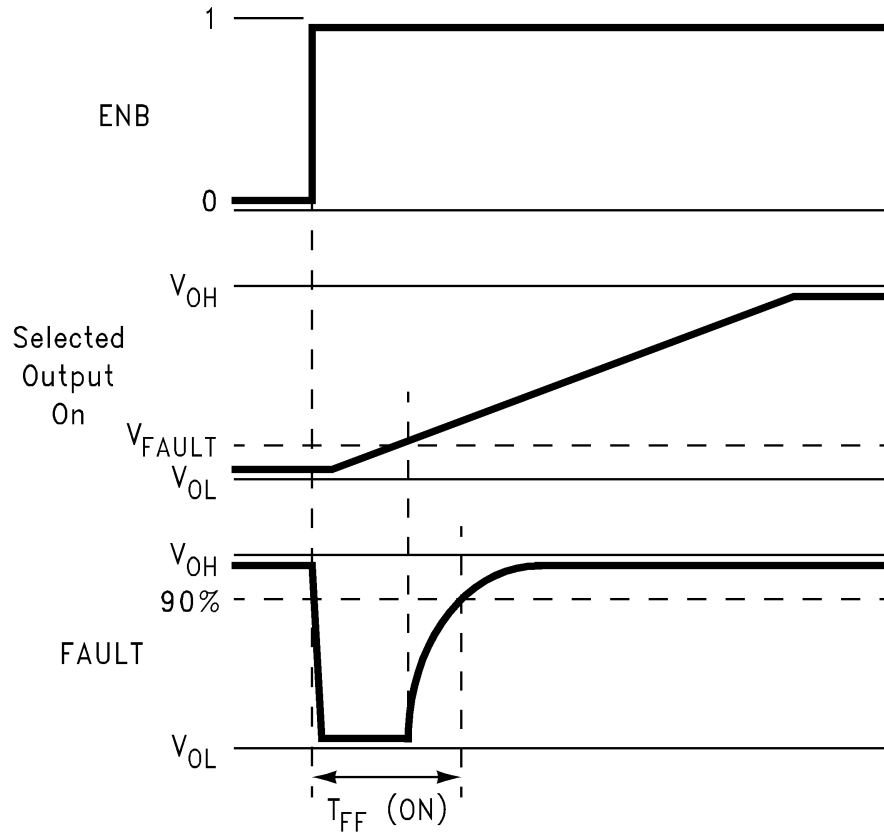

Figure 13. False FAULT Time for Disabled Sx Output



**Figure 14. False FAULT Time for Enabled Sx Output**

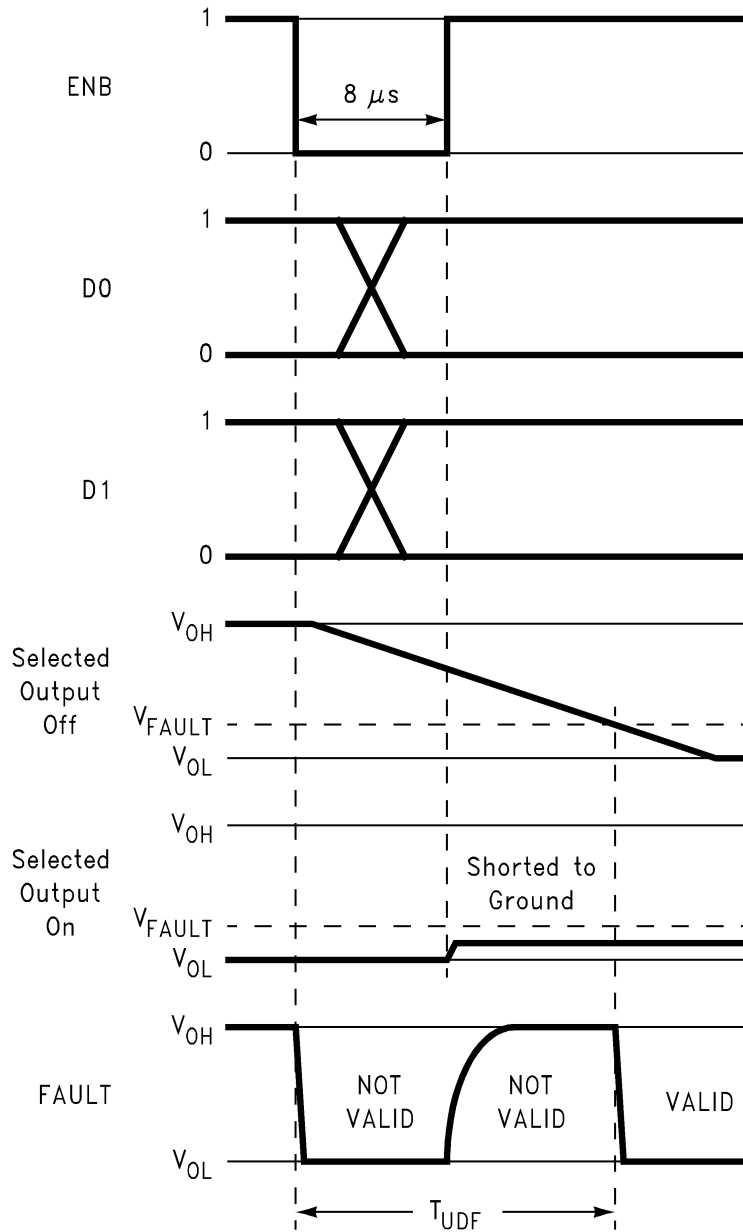
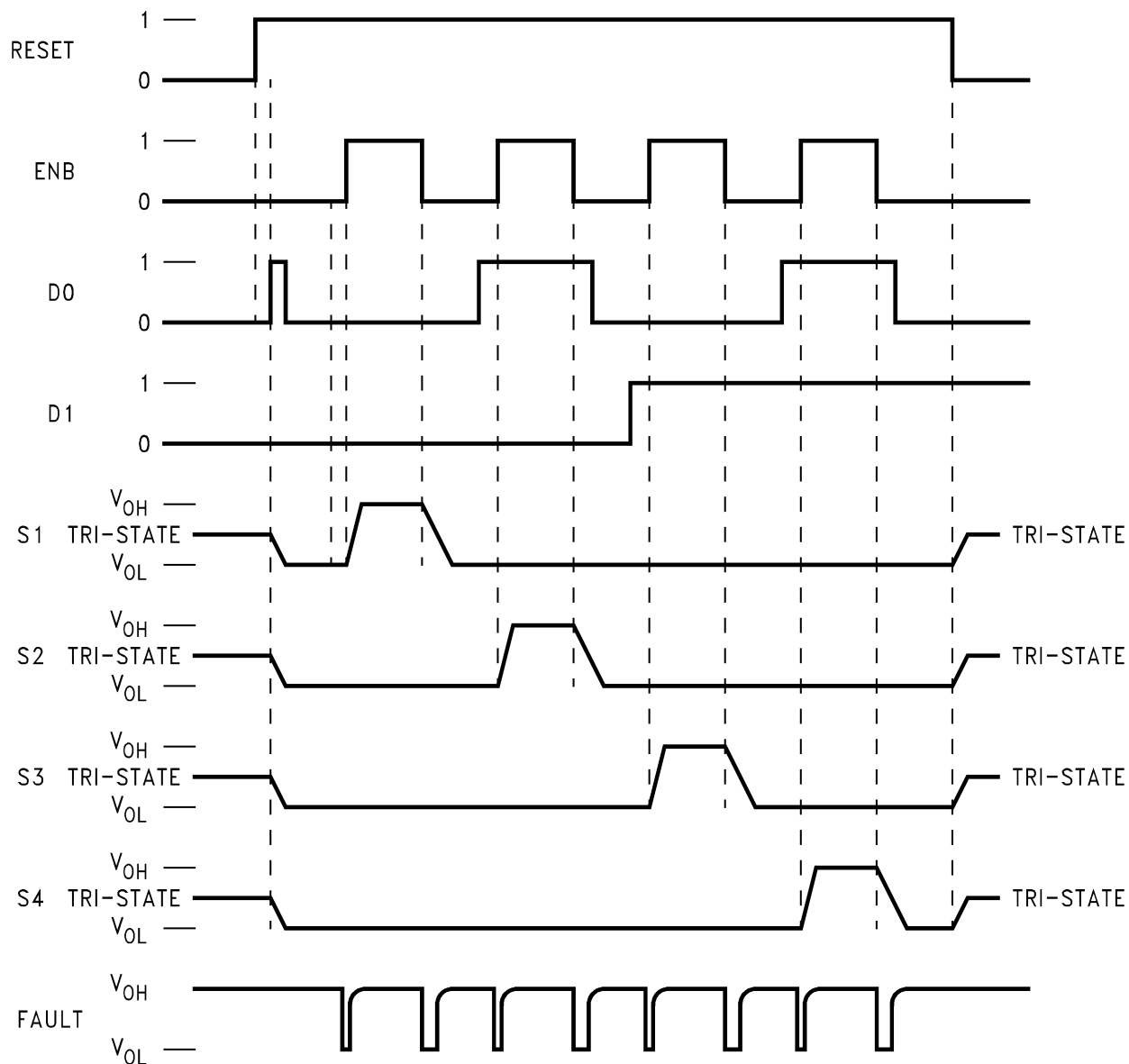

Figure 15. Time for Valid Fault Detection



**Figure 16. Electronic Timing Interface Typical Waveforms**

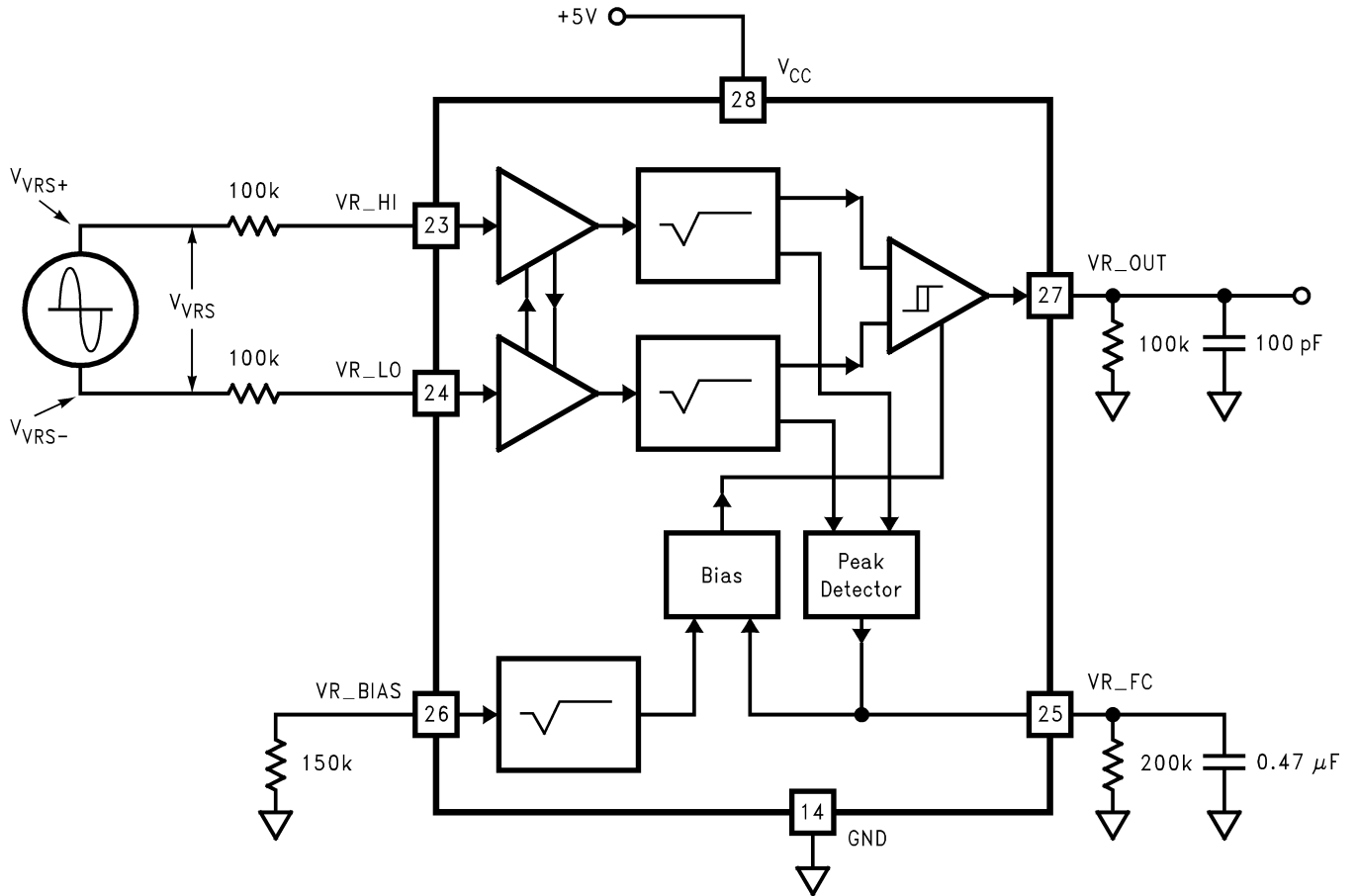
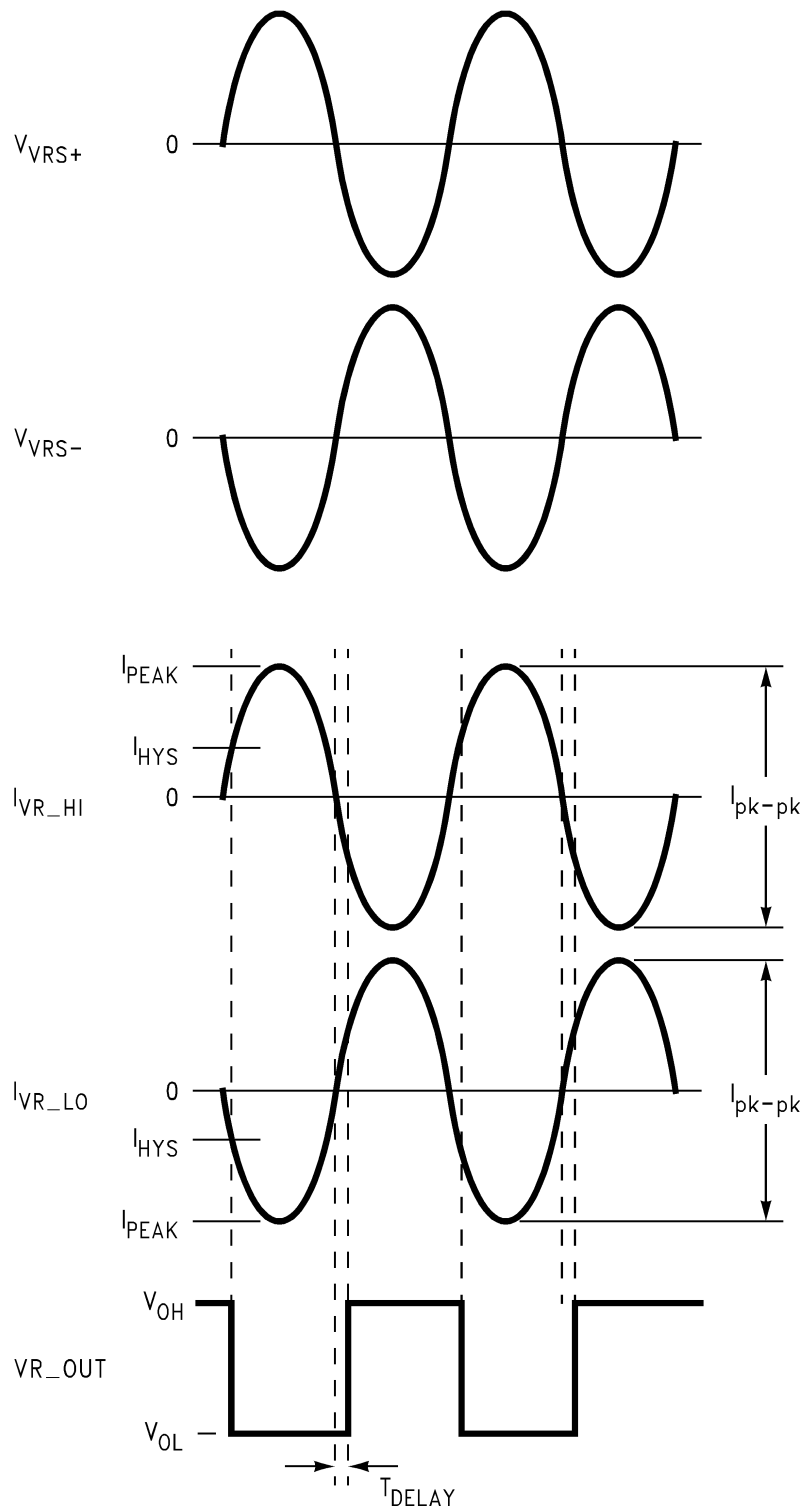

Figure 17. VR Interface Test Circuit



**Figure 18. VR Interface Timing Diagram**

## CIRCUIT DESCRIPTION

### VR SENSOR INTERFACE

The differential inputs, VR\_HI and VR\_LO are low impedance inputs with a DC voltage bias of one half of V<sub>cc</sub>. Both inputs require equal value series resistance on their respective pins to convert the VR sensor voltage to a differential input current. The differential input current range is typically 2.5μA peak-to-peak to 2.5mA peak-to-peak. Each input has active current limiting that will clamp the current at typically +/-5mA. This is intended for short circuit protection and not for input signal limiting.

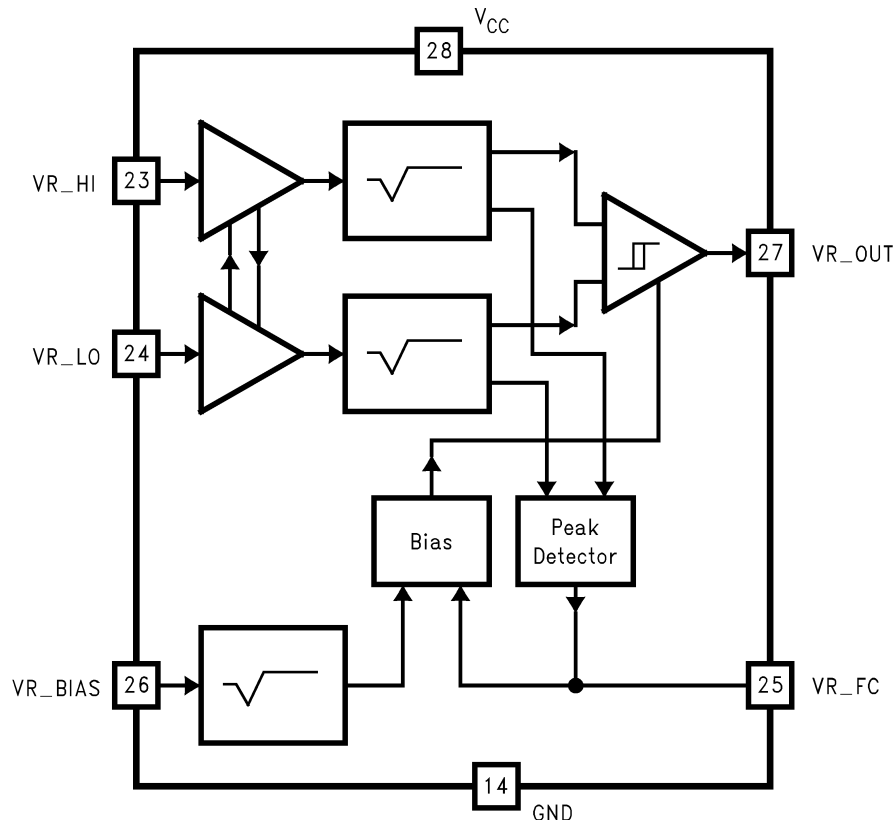

Figure 19. VR Sensor Interface Block Diagram

Differential voltages of 500mV peak-to-peak to 500V peak-to-peak can be processed with the specified 100KΩ series resistor on each input. Numerous variables will determine the output voltage signal from a VR sensor across a frequency range. The input resistors can be scaled from typically 50KΩ to 200KΩ to keep the differential input current within the recommended range for a given VR Sensor output voltage. Bypass capacitors can be added to form a low pass filter to limit the differential input signal at the higher frequencies.

The VR Sensor interface utilizes a dynamic hysteresis which will increase the hysteresis level as the input signal from the VR Sensor increases. The circuit requires two external components to fully implement the hysteresis function: a capacitor on VR\_FC to filter and store the peak detector signals; and a 150KΩ resistor on VR\_BIAS to set a reference current for the hysteresis circuit. The typical value range for the peak detector storage capacitor is 0.1μF to 0.47μF.

The peak detector has an internal 3KΩ (typical) current limiting resistor to V<sub>cc</sub> for charging the storage capacitor. An external resistor in parallel with the peak detector storage capacitor is used to set the RC discharge rate of the peak detector capacitor.

For input levels greater than typically  $10\mu\text{A}$  peak-to-peak the voltage on the peak detector output pin VR\_FC is used to actively derive the hysteresis level. The active hysteresis will typically be 30% of the peak input signal. As the input level falls below typically  $10\mu\text{A}$  peak-to-peak the hysteresis level will begin to rise as the static hysteresis level takes effect. The static hysteresis level is set by the current out of the VR\_BIAS pin and is a constant level of typically  $1\mu\text{A}$  peak with a VR\_BIAS resistor of  $150\text{K}\Omega$ . This static hysteresis level acts as the minimum detect threshold as there will be no output if the input signal is not greater than the static hysteresis level.

The VR\_BIAS resistor can be scaled from typically  $50\text{K}\Omega$  to  $500\text{K}\Omega$ , but the practical range is typically  $75\text{K}\Omega$  to  $300\text{K}\Omega$ . Increasing the resistance (i.e. reducing the current) will lower the minimum hysteresis level. Conversely, reducing the resistance will raise the minimum hysteresis level. Since the VR\_BIAS current is modified by the same square root circuit used for the input signal, the relationship between the VR\_BIAS resistor value and the minimum detect level is not linear. For VR\_BIAS values greater than  $500\text{K}\Omega$ , the minimum detect level is typically determined more by the internal device offsets, and thermal effects.

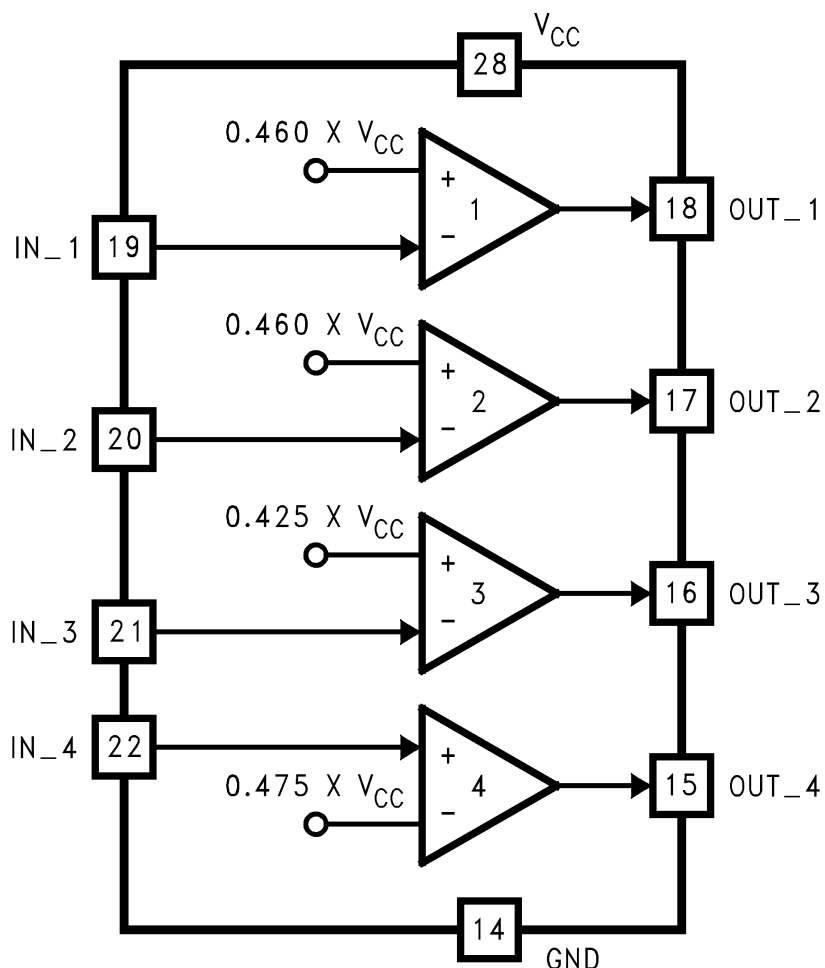

Figure 20. Voltage Comparator Block Diagram

## VOLTAGE COMPARATORS

The circuit includes four general purpose voltage comparators that use an internal reference voltage to set their voltage thresholds. Three of the comparators have their non-inverting inputs tied to the internal reference voltage, and their inverting-inputs are brought out. The remaining one comparator has its inverting input tied to the internal voltage reference, and its non-inverting input is brought out. All four comparators include hysteresis to improve noise immunity. The comparator outputs are internally pulled up to  $V_{CC}$ . Any un-used comparator should have its input connected to device ground.

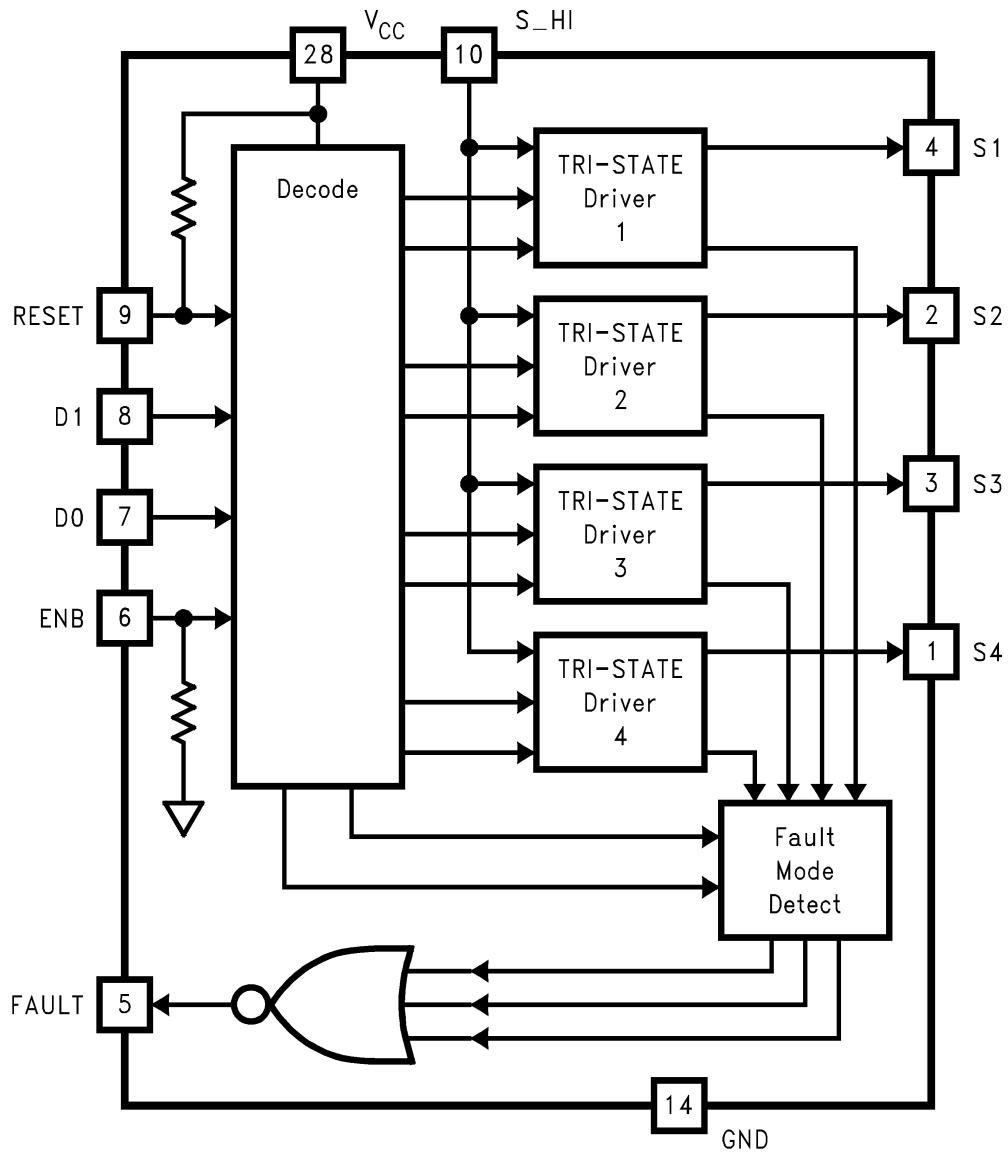

Figure 21. Electronic Timing Interface Block Diagram

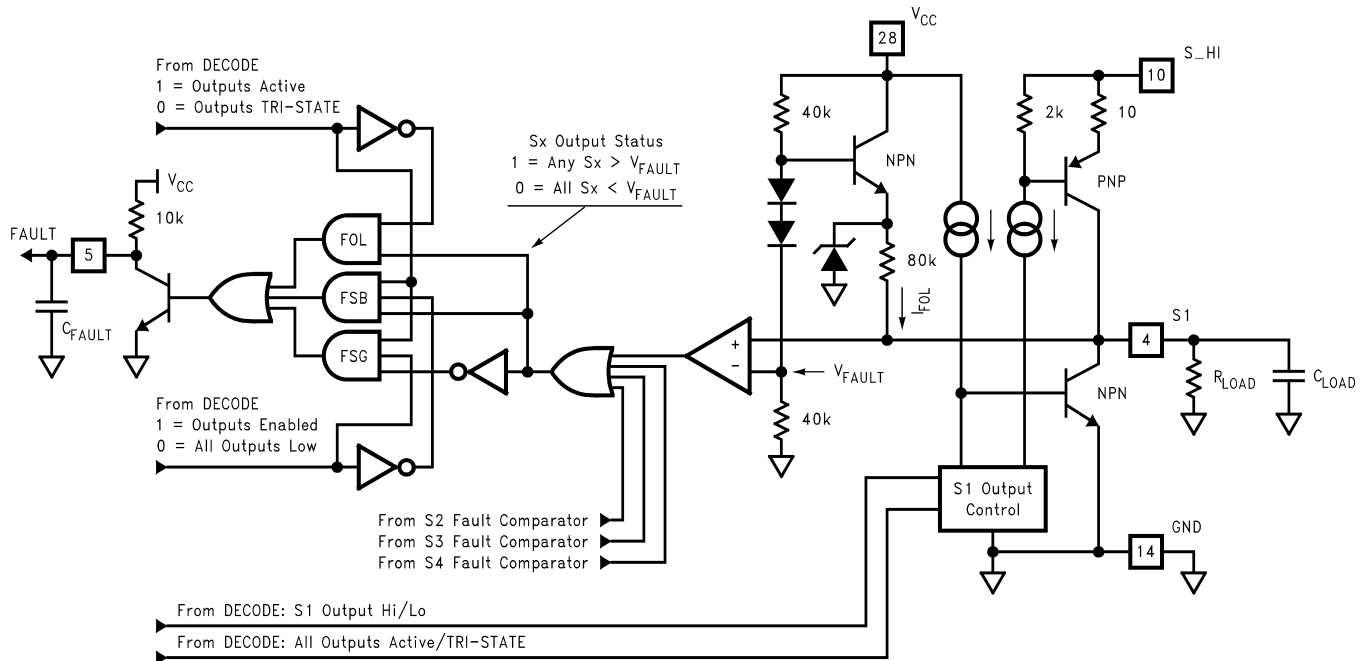

Figure 22. Output Fault Detection Block Diagram

Table 1. Electronic Timing Interface

Inputs				Output			
RESET	ENB	D0	D1	S1	S2	S3	S4
0	X	X	X	Tri	Tri	Tri	Tri
1	0	X	X	L	L	L	L
1	1	0	0	H	L	L	L
1	1	1	0	L	H	L	L
1	1	0	1	L	L	H	L
1	1	1	1	L	L	L	H

The Electronic Timing Interface provide signals to the spark module from the micro-processor. The interface requires four input data signals, and provides four output control channels.

The interface also provides one output channel for diagnostic information for any open or shorted loads on S1 to S4. The RESET pin has an internal pull-up resistor to  $V_{CC}$  of typically 100K $\Omega$ , and the ENB pin has an internal pull-down resistor to ground of typically 100K $\Omega$ .

To put the outputs into the Tri-State mode at power-on, the RESET pin should be held low until  $V_{CC}$  is above 4.75V. This can be accomplished by micro-processor control, or by adding a capacitor from the RESET pin to ground.

The RESET pin is used to disable the spark driver outputs by putting them in a Tri-State mode. While in the Tri-State mode the Open Output Fault detection circuitry is active. An open Output is detected by forcing a small current ( $I_{FOL}$ ) through the outputs to the loads, and monitoring the voltage on the output pins rises above the Output Fault Threshold Voltage ( $V_{FAULT}$ ) the FAULT pin will be forced low. The intent is to detect an open wire condition, and not necessarily to detect a local resistance threshold.

Note that if any output has a Short to battery fault, the fault pin will go low during this Tri-State mode. The internal comparator is unable to discern why an output pin may be above the Fault Threshold Voltage, only that it is. In any case, a fault is reported, even if it is not the anticipated fault.

The Tri-State mode is a latched condition. For the outputs to come out of the Tri-State mode, the RESET pin must be high, and then the data input pin D0 must toggle from a low state to a high state. The state of the outputs will now be set by the data inputs D0 and D1, and the ENB input. If ENB is low when the Tri-State mode is cleared, all of the outputs will go low.

Pins D0 and D1 are used select an output, and ENB will enable the selected output. The outputs have active pull up to S\_HI, and the active pull down to Ground. The default not enabled output conditions is low, and the enabled output condition is high. Only one output can be enabled (high) at a time. The outputs are not latched in any state and will follow the input selected with D0 and D1 as long as ENB is high.

The detection of an output shorted to ground, or battery, is dependent on the status of ENB. While ENB is logical 0, all of the outputs are forced low and the Short to Battery fault detection circuitry is active. A Short to Battery is detected by monitoring the voltage on the output pins. If the voltage on any output pin is above the Fault Threshold Voltage ( $V_{FAULT}$ ) the FAULT pin will go low. The output current sink is limited to typically 8mA. The short to battery condition must be able to provide enough current to overcome the current limit and raise the output pin voltage above the  $V_{FAULT}$  threshold.

When ENB is logical 1, the selected output will be high and the Short to Ground detection circuitry is active. A Short to Ground is detected by monitoring the voltage on the output pins. If the voltage on the selected output pin is below the Fault Threshold Voltage ( $V_{FAULT}$ ) the FAULT pin will go low. The output current source is from S\_HI limited to typically 25mA to 50mA across the S\_HI voltage range. The short to ground condition must be allow enough resistance to allow the output pin voltage to fall below the  $V_{FAULT}$  threshold with the output sourcing short circuit current. Typically, a short to ground which has 100 Ohms of resistance, or more, can not be reliably detected. Typically, a short to ground of 20 Ohms, or less, can be reliably detected across the entire S\_HI voltage range and device operating temperature range. Note that if any output has a Short to Battery fault, a Short to Ground cannot be detected.

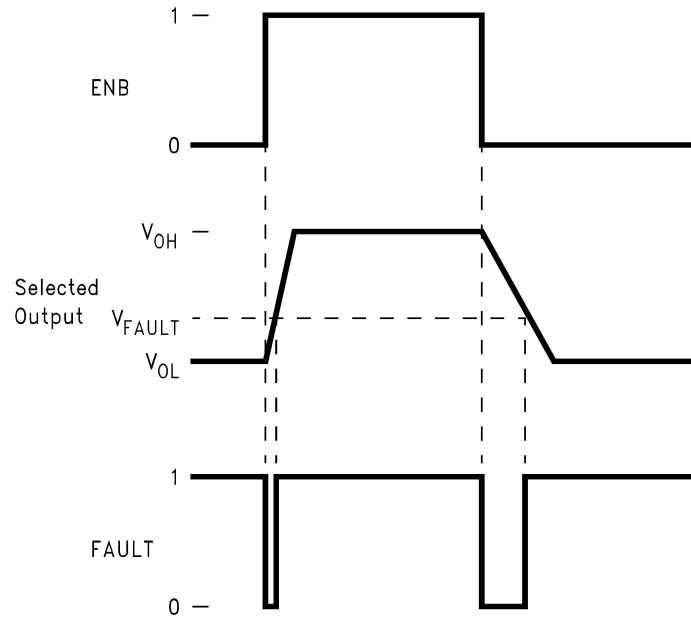

**Figure 23. FAULT Pin Output During Normal Operation**

The internal logic is unable to discern which output pin is above the Fault Threshold Voltage, only that a pin is. Thus, the logical requirement of an Sx pin voltage above the Fault Threshold voltage is met and no fault is reported.

The output rise and fall times are basically a function of the output current drive (source and sink) and the output load characteristics. Due to the scaling of the output stages, and variations in the value of S\_HI, the fall time will typically be two to ten times longer than the rise time for a given capacitive load.

Since the output fault detection mode changes immediately with the status of the ENB pin, and the voltage on the output pin cannot change instantly, the FAULT pin will go low during the output transition times. The FAULT pin will stay low until the output voltage rises above, or falls below, the active fault threshold. See [Figure 23](#).

When switching the outputs from the active mode to the Tri-State mode the ENB should be taken low first. This will take all of the outputs low. Then the RESET pin can be taken low. This will eliminate false 'open' faults that will be generated while waiting for the one output that was high, to discharge any capacitance below the  $V_{FAULT}$  threshold.

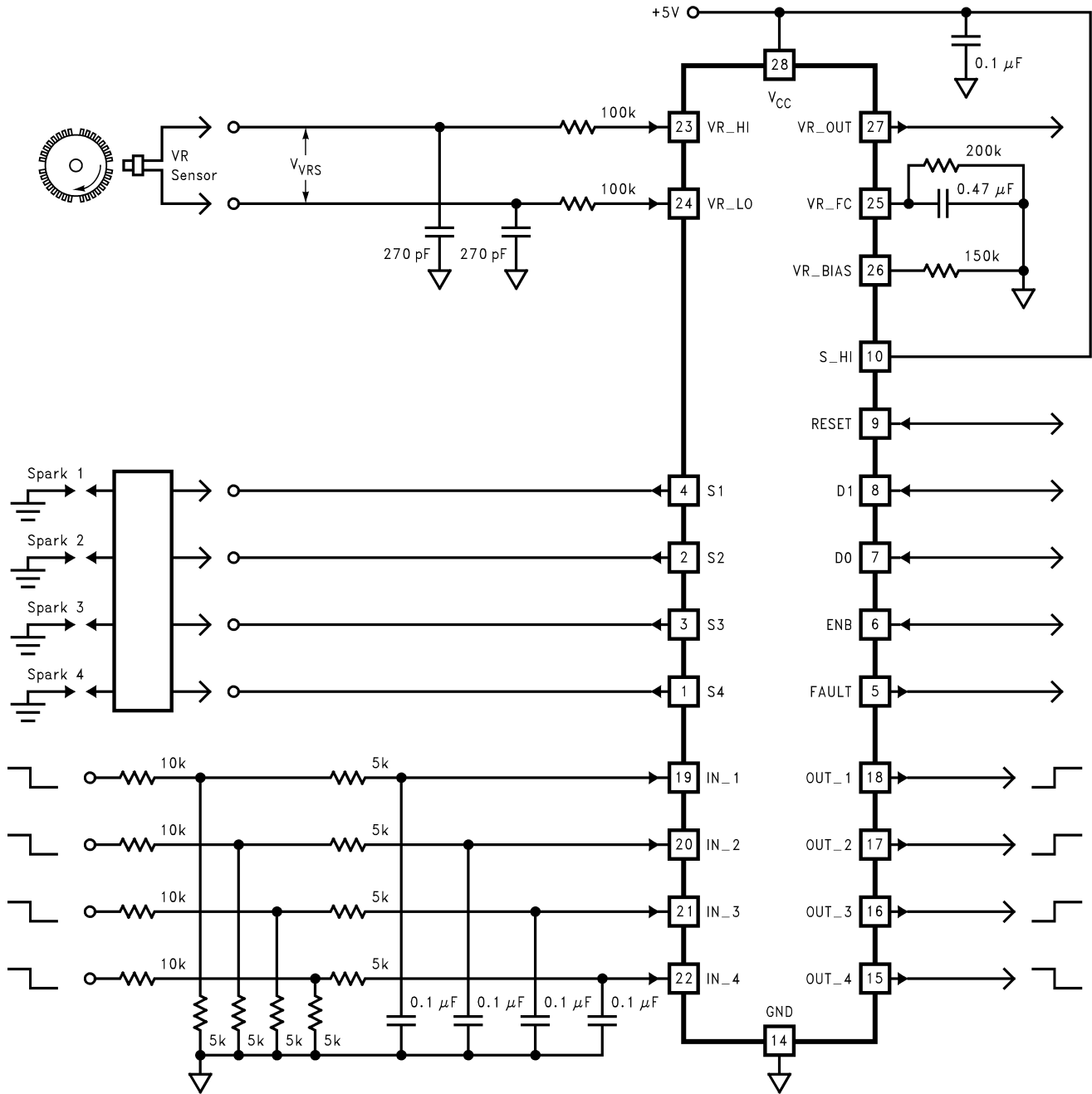

Figure 24. Typical Application

## REVISION HISTORY

Changes from Revision C (April 2013) to Revision D	Page
• Changed layout of National Data Sheet to TI format .....	<a href="#">21</a>

## IMPORTANT NOTICE

Texas Instruments Incorporated and its subsidiaries (TI) reserve the right to make corrections, enhancements, improvements and other changes to its semiconductor products and services per JESD46, latest issue, and to discontinue any product or service per JESD48, latest issue. Buyers should obtain the latest relevant information before placing orders and should verify that such information is current and complete. All semiconductor products (also referred to herein as "components") are sold subject to TI's terms and conditions of sale supplied at the time of order acknowledgment.

TI warrants performance of its components to the specifications applicable at the time of sale, in accordance with the warranty in TI's terms and conditions of sale of semiconductor products. Testing and other quality control techniques are used to the extent TI deems necessary to support this warranty. Except where mandated by applicable law, testing of all parameters of each component is not necessarily performed.

TI assumes no liability for applications assistance or the design of Buyers' products. Buyers are responsible for their products and applications using TI components. To minimize the risks associated with Buyers' products and applications, Buyers should provide adequate design and operating safeguards.

TI does not warrant or represent that any license, either express or implied, is granted under any patent right, copyright, mask work right, or other intellectual property right relating to any combination, machine, or process in which TI components or services are used. Information published by TI regarding third-party products or services does not constitute a license to use such products or services or a warranty or endorsement thereof. Use of such information may require a license from a third party under the patents or other intellectual property of the third party, or a license from TI under the patents or other intellectual property of TI.

Reproduction of significant portions of TI information in TI data books or data sheets is permissible only if reproduction is without alteration and is accompanied by all associated warranties, conditions, limitations, and notices. TI is not responsible or liable for such altered documentation. Information of third parties may be subject to additional restrictions.

Resale of TI components or services with statements different from or beyond the parameters stated by TI for that component or service voids all express and any implied warranties for the associated TI component or service and is an unfair and deceptive business practice. TI is not responsible or liable for any such statements.

Buyer acknowledges and agrees that it is solely responsible for compliance with all legal, regulatory and safety-related requirements concerning its products, and any use of TI components in its applications, notwithstanding any applications-related information or support that may be provided by TI. Buyer represents and agrees that it has all the necessary expertise to create and implement safeguards which anticipate dangerous consequences of failures, monitor failures and their consequences, lessen the likelihood of failures that might cause harm and take appropriate remedial actions. Buyer will fully indemnify TI and its representatives against any damages arising out of the use of any TI components in safety-critical applications.

In some cases, TI components may be promoted specifically to facilitate safety-related applications. With such components, TI's goal is to help enable customers to design and create their own end-product solutions that meet applicable functional safety standards and requirements. Nonetheless, such components are subject to these terms.

No TI components are authorized for use in FDA Class III (or similar life-critical medical equipment) unless authorized officers of the parties have executed a special agreement specifically governing such use.

Only those TI components which TI has specifically designated as military grade or "enhanced plastic" are designed and intended for use in military/aerospace applications or environments. Buyer acknowledges and agrees that any military or aerospace use of TI components which have **not** been so designated is solely at the Buyer's risk, and that Buyer is solely responsible for compliance with all legal and regulatory requirements in connection with such use.

TI has specifically designated certain components as meeting ISO/TS16949 requirements, mainly for automotive use. In any case of use of non-designated products, TI will not be responsible for any failure to meet ISO/TS16949.

### Products

Audio	<a href="http://www.ti.com/audio">www.ti.com/audio</a>
Amplifiers	<a href="http://amplifier.ti.com">amplifier.ti.com</a>
Data Converters	<a href="http://dataconverter.ti.com">dataconverter.ti.com</a>
DLP® Products	<a href="http://www.dlp.com">www.dlp.com</a>
DSP	<a href="http://dsp.ti.com">dsp.ti.com</a>
Clocks and Timers	<a href="http://www.ti.com/clocks">www.ti.com/clocks</a>
Interface	<a href="http://interface.ti.com">interface.ti.com</a>
Logic	<a href="http://logic.ti.com">logic.ti.com</a>
Power Mgmt	<a href="http://power.ti.com">power.ti.com</a>
Microcontrollers	<a href="http://microcontroller.ti.com">microcontroller.ti.com</a>
RFID	<a href="http://www.ti-rfid.com">www.ti-rfid.com</a>
OMAP Applications Processors	<a href="http://www.ti.com/omap">www.ti.com/omap</a>
Wireless Connectivity	<a href="http://www.ti.com/wirelessconnectivity">www.ti.com/wirelessconnectivity</a>

### Applications

Automotive and Transportation	<a href="http://www.ti.com/automotive">www.ti.com/automotive</a>
Communications and Telecom	<a href="http://www.ti.com/communications">www.ti.com/communications</a>
Computers and Peripherals	<a href="http://www.ti.com/computers">www.ti.com/computers</a>
Consumer Electronics	<a href="http://www.ti.com/consumer-apps">www.ti.com/consumer-apps</a>
Energy and Lighting	<a href="http://www.ti.com/energy">www.ti.com/energy</a>
Industrial	<a href="http://www.ti.com/industrial">www.ti.com/industrial</a>
Medical	<a href="http://www.ti.com/medical">www.ti.com/medical</a>
Security	<a href="http://www.ti.com/security">www.ti.com/security</a>
Space, Avionics and Defense	<a href="http://www.ti.com/space-avionics-defense">www.ti.com/space-avionics-defense</a>
Video and Imaging	<a href="http://www.ti.com/video">www.ti.com/video</a>

### TI E2E Community

[e2e.ti.com](http://e2e.ti.com)

## Looking for pricing, stock, or lifecycle information?

Click below to explore more details on WIN SOURCE:

 [View LM9011MX](#) on WIN SOURCE

 [Texas Instruments](#) Information

## Optimize Your Supply Chain with WIN SOURCE Solutions

-  Global Sourcing Solution
-  Obsolete Management
-  Cost Control Management
-  Shortage Management
-  Alternative Solution
-  Excess Inventory Management