



THE DATASHEET OF LM9072S



LM9072 Dual Tracking Low-Dropout System Regulator

Check for Samples: [LM9072](#)

FEATURES

- **Two 5V Regulated Outputs:**
 - 350 mA, 2% Main Output
 - 80 mA, 1.5% Tracking Output
- **Good EMI (1 MHz to 400 MHz, BCI) Immunity**
- **Separate ON/OFF and Keep-Alive Control Inputs**
- **Less Than 100 μ A Quiescent Current in OFF State**
- **Programmable Delayed Reset Output**
- **Input Transient Protection Over 60V to –45V**
- **Tracking Output Protected From Shorts to Battery**
- **Less Than 1V Dropout at Full Load**
- **–40°C to +125°C Operating Temperature Range**
- **Surface Mount SFM Power Package**

TYPICAL APPLICATIONS

- **Automotive Module Supply Power Conditioning**
- **Remote Sensor Biasing**
- **Ratiometric to Supply Sensor Detection**
- **Continuous Operation for Save Routines and EPROM Programming After Power Down Command**
- **Safety Related Systems—EMC Operational**

CONNECTION DIAGRAM

Backside metal is internally connected to ground.

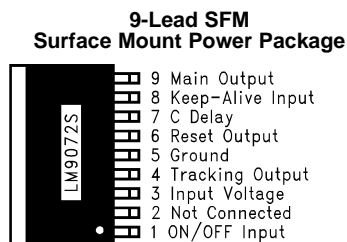

Figure 1. See Package Number KTW

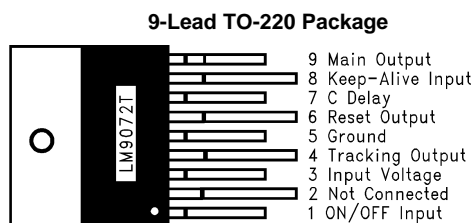

Figure 2. See Package Number TA9A

DESCRIPTION

The LM9072 is a high performance voltage regulator system with operational and protection features that address many requirements of automotive applications. Two regulated outputs are provided. The main regulator provides a precision 2% maximum tolerance 5V output at 350mA with a low dropout characteristic. The second regulator provides a 5V output that tracks the main regulator output voltage within 1.5% with load currents up to 80mA. The tracking output is ideal for use in powering remotely located sensors with outputs that are ratiometric to the main system supply. This output is fully protected from short circuits to ground or the unregulated input supply (ignition or battery potentials in automotive applications).

The LM9072 also contains a programmable delayed system reset output. Two control inputs are provided. An ON/OFF input intended for connection to an ignition switch, and a Keep Alive input to allow a system to remain powered after ignition has been switched OFF.

For EMC concerns the LM9072 remains fully operational and does not generate false reset signals while subjected to, 1MHz to 400 MHz bulk current injection signals greater than 100 mA on the input supply and tracking output lines.



Please be aware that an important notice concerning availability, standard warranty, and use in critical applications of Texas Instruments semiconductor products and disclaimers thereto appears at the end of this data sheet.

All trademarks are the property of their respective owners.



These devices have limited built-in ESD protection. The leads should be shorted together or the device placed in conductive foam during storage or handling to prevent electrostatic damage to the MOS gates.

ABSOLUTE MAXIMUM RATINGS⁽¹⁾⁽²⁾

Input Voltage (Continuous)		-45V to 45V
Input Voltage (Transient, $t \leq 400$ ms)		60V
Forced Output Voltages	Main Output	-0.3V to 7V
	Tracking Output	-0.3V to 27V
ON/OFF Input Voltage ⁽³⁾		-0.3V to 16V
ON/OFF Input Current		± 20 mA
Keep Alive In, Reset Out, C_{DELAY} Voltage		-0.3V to 7V
Junction Temperature		150°C
Storage Temperature Range		-65°C to +150°C
ESD Susceptibility ⁽⁴⁾		2000V
Lead Temperature (Soldering, 10 seconds)		265°C

- (1) Absolute Maximum Ratings indicate limits beyond which damage to the device may occur. Operating Ratings indicate conditions for which the device remains functional but do not ensure specific performance limits. For ensured specifications and test conditions see the Electrical Characteristics.
- (2) If Military/Aerospace specified devices are required, please contact the Texas Instruments Sales Office/Distributors for availability and specifications.
- (3) The ON/OFF input is internally clamped to a 7V zener diode through a 1 k Ω resistor.
- (4) Human body model, 150 pF capacitor discharged through a 1.5 k Ω resistor.

OPERATING RATINGS⁽¹⁾

Input Voltage Range		6V to 27V
Ambient Temperature Range		-40°C to +125°C
TO-220 Thermal Resistance, θ_{J-C}		3°C/W
TO-220 Thermal Resistance, θ_{J-A} ⁽²⁾		73°C/W
SFM Thermal Resistance, θ_{J-C}		3°C/W
SFM Thermal Resistance, θ_{J-A} ⁽³⁾		80°C/W

- (1) Absolute Maximum Ratings indicate limits beyond which damage to the device may occur. Operating Ratings indicate conditions for which the device remains functional but do not ensure specific performance limits. For ensured specifications and test conditions see the Electrical Characteristics.
- (2) Exceeding the Maximum Allowable power dissipation will cause excessive die temperature, and the device will go into thermal shutdown. The θ_{J-A} value for the TO-220 package (still air, no additional heat sink) is 73°C/W. The effective θ_{J-A} value of the TO-220 package can be reduced by using conventional heat sink methods.
- (3) Exceeding the Maximum Allowable power dissipation will cause excessive die temperature, and the device will go into thermal shutdown. The θ_{J-A} value for the SFM package (still air, no additional heat sink) is 80°C/W. The effective θ_{J-A} value of the SFM package can be reduced by increasing the printed circuit board area that is connected (soldered) to the package tab. Using 1 ounce (1.4 mils thick) copper clad with no solder mask, an area of 0.5 square inches will reduce θ_{J-A} to 50°C/W, an area of 1.0 square inches will reduce θ_{J-A} to 37°C/W, and an area of 1.6 square inches will reduce θ_{J-A} to 32°C/W. If the printed circuit board uses a solder mask, the copper clad area should be increased by at least 50% to maintain a similar θ_{J-A} rating.

ELECTRICAL CHARACTERISTICS⁽¹⁾

$6.0V \leq V_{IN} \leq 19V$, $T_{CASE} = 25^\circ C$, unless otherwise specified. $C_{OUT} \geq 6 \mu F$ with $0.3\Omega \leq ESR \leq 3\Omega$ on each regulator output.

Symbol	Parameter	Conditions	Min	Max	Units
MAIN REGULATOR					
V_{MAIN}	Main Output Voltage	$5 \text{ mA} \leq I_{LOAD} \leq 350 \text{ mA}$ $-40^\circ C \leq T_{CASE} \leq 125^\circ C$	4.9	5.1	V
		$19V \leq V_{IN} \leq 30V$ $5 \text{ mA} \leq I_{LOAD} \leq 350 \text{ mA}$ $-40^\circ C \leq T_{CASE} \leq 125^\circ C$	4.8	5.2	V
R_{MLOAD}	Load Regulation	$V_{IN} = 16V$, $5 \text{ mA} \leq I_{LOAD} \leq 350 \text{ mA}$		25	mV
R_{MLINE}	Line Regulation	$I_{LOAD} = 350 \text{ mA}$, $8V \leq V_{IN} \leq 16V$		25	mV

- (1) Datasheet min/max specifications are specified by design, test, and/or statistical analysis.

ELECTRICAL CHARACTERISTICS⁽¹⁾ (continued)
 $6.0V \leq V_{IN} \leq 19V$, $T_{CASE} = 25^{\circ}C$, unless otherwise specified. $C_{OUT} \geq 6 \mu F$ with $0.3\Omega \leq ESR \leq 3\Omega$ on each regulator output.

Symbol	Parameter	Conditions	Min	Max	Units
V_{MDO}	Dropout Voltage, $V_{IN}-V_{MAIN}$	$V_{IN} > 5.5V$, $5 mA \leq I_{LOAD} \leq 350 mA$ ⁽²⁾		0.8	V
V_{SD}	Overshoot Shutdown Threshold		30	36	V
I_{MSC}	Output Short Circuit Current	$R_L = 1\Omega$	450	1000	mA
R_{MRR}	Ripple Rejection	$V_{IN} = 9V$, $50 \leq Freq \leq 20 kHz$, $V_{RIPPLE} = 4V_{P-P}$	40		dB
TRACKING REGULATOR					
V_{TRACK}	Tracking Output Voltage	$1 mA \leq I_{LOAD} \leq 80 mA$ $-40^{\circ}C \leq T_{CASE} \leq 125^{\circ}C$	4.85	5.15	V
		$19V \leq V_{IN} \leq 30V$ $1 mA \leq I_{LOAD} \leq 80 mA$ $-40^{\circ}C \leq T_{CASE} \leq 125^{\circ}C$	4.725	5.275	V
V_{ERROR}	Output Tracking Error ($V_{MAIN}-V_{TRACK}$)	$1 mA \leq I_{LOAD} \leq 80 mA$	-50	50	mV
V_{TDO}	Dropout Voltage, $V_{IN}-V_{TRACK}$	$V_{IN} > 5.5V$, $1 mA \leq I_{LOAD} \leq 80 mA$ ⁽²⁾		0.8	V
I_{TSC}	Output Short Circuit Current	$R_L = 1\Omega$		200	mA
V_{TSC}	Output Short Circuit Voltage	No Effect On Other Functions	-2	27	V
R_{TRR}	Ripple Rejection	$V_{IN} = 9V$, $50 \leq Freq \leq 20 kHz$, $V_{RIPPLE} = 4V_{P-P}$	40		dB
INPUT CURRENT					
I_{qOFF}	Quiescent Input Current with Both Regulators OFF	$8V \leq V_{IN} \leq 16V$		40	μA
		$16V \leq V_{IN} \leq 42V$		10	mA
I_q	No Load Quiescent Current	$8V \leq V_{IN} \leq 19V$, $I_L = 0 mA$		15	mA
I_{ON}	Additional Input Current with Both Regulators ON	$V_{IN} > 8V$, $I_{Ltotal} = I_{Lmain} + I_{Ltrack}$ $I_{Ltotal} = 350 mA + 80 mA = 430 mA$		1.2	$\times I_{Ltotal}$
I_{inDO}	Additional Input Current in Dropout	$0V < V_{IN} < 8V$, ⁽³⁾ $I_{Ltotal} = I_{Lmain} + I_{Ltrack}$ $I_{Ltotal} = 350 mA + 80 mA = 430 mA$		1.5	$\times I_{Ltotal}$
RESET OUTPUT					
V_{THRL}	Low Switching Threshold	V_{MAIN} Output Controls Reset	4.45	4.75	V
V_{THRH}	High Switching Threshold	V_{MAIN} Output Controls Reset	5.40	5.75	V
V_{LOW}	Logic Low Output Voltage	$1V \leq V_{MAIN} \leq V_{THRL}$, $R_{RESET} = 50 k\Omega$ to V_{MAIN}		0.4	V
V_{HIGH}	Logic High Output Voltage	Normal Operation, $V_{THRL} \leq V_{MAIN} \leq V_{THRH}$, $I_{SOURCE} = 0$	$V_{MAIN}-$ 50 mV	V_{MAIN}	V
R_{P-U}	Internal Output Pull-Up Resistance		2.4	6.0	k Ω
T_{DELAY}	Reset Delay Interval	$C_{DELAY} = 0.1 \mu F$ (Low Leakage), I_{DELAY} for Charging the Delay Capacitor is Typically 6 μA	35	70	ms
T_{RISE}	Output Rise Time	From 10% V_{MAIN} to 90% V_{MAIN} $C_{LRESET} = 50 pF$		1.5	μs
T_{FALL}	Output Fall Time	From 90% V_{MAIN} to 10% V_{MAIN} $C_{LRESET} = 50 pF$		0.5	μs
CONTROL INPUTS					
V_{ON}	ON Threshold for ON/OFF Input	$R_{SERIES} = 22 k\Omega$	3.5	4.5	V
V_{OFF}	OFF Threshold for ON/OFF Input	$R_{SERIES} = 22 k\Omega$ ⁽⁴⁾	1.5	2.5	V

- (2) The dropout voltage specifications actually indicate the saturation voltage of the PNP power transistors used in each regulator. Over the full load current and temperature ranges both regulators will output at least 4.7V with an input voltage of only 5.5V.
- (3) The input quiescent current will increase when the regulators are in dropout conditions. The amount of additional input currents is a direct function of the total load current on both outputs. The peak increase in current is limited to 50% of the total load current.
- (4) If either control input is left open circuited the regulators will turn OFF.

ELECTRICAL CHARACTERISTICS⁽¹⁾ (continued)

$6.0V \leq V_{IN} \leq 19V$, $T_{CASE} = 25^{\circ}C$, unless otherwise specified. $C_{OUT} \geq 6 \mu F$ with $0.3\Omega \leq ESR \leq 3\Omega$ on each regulator output.

Symbol	Parameter	Conditions	Min	Max	Units
$I_{ON/OFF}$	ON/OFF Input Current	$1.4V \leq V_{ON/OFF} \leq 4.5V$	1	12	μA
		$-0.3V \leq V_{ON/OFF} \leq 7V$ ⁽⁵⁾	-1	5	mA
ON_{K-A}	Turn ON Threshold for Keep Alive Input		2		V
OFF_{K-A}	Turn OFF Threshold for Keep Alive Input	⁽⁴⁾		0.8	V
R_{P-D}	Pull-Down Resistance at Keep Alive Input	$0V \leq V_{K-A} \leq 5V$	5	40	k Ω

(5) The ON/OFF input is internally clamped to a 7V zener diode through a 1 k Ω resistor.

TYPICAL PERFORMANCE CHARACTERISTICS

($T_A = 25^\circ\text{C}$ unless otherwise specified)

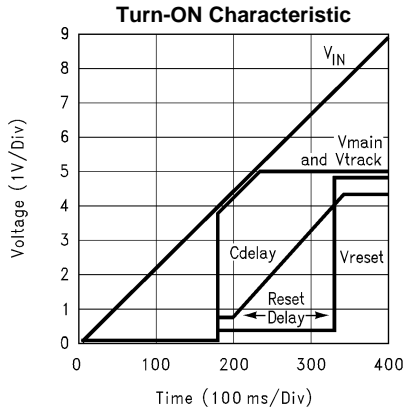

Figure 3.

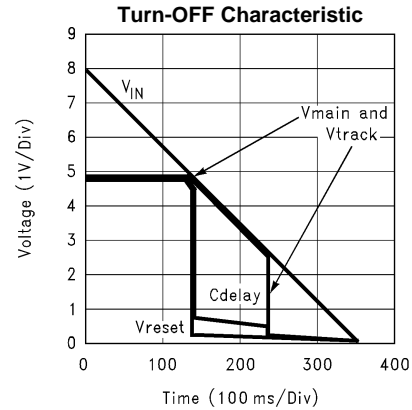

Figure 4.

Normalized Main Output Voltage vs Temperature

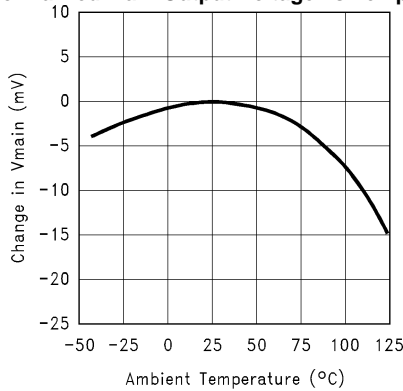

Figure 5.

Quiescent Input Current vs Input Voltage

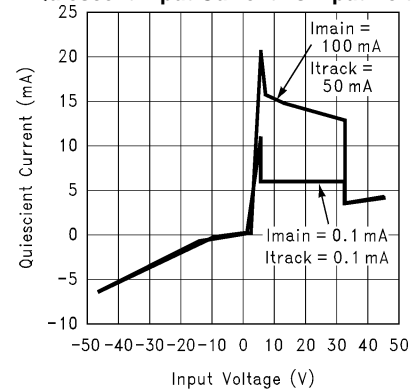

Figure 6.

Main Output Voltage at Input Voltage Extremes

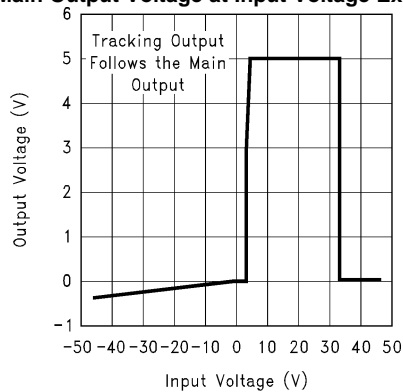

Figure 7.

Input Current vs Input Voltage (Regulators OFF)

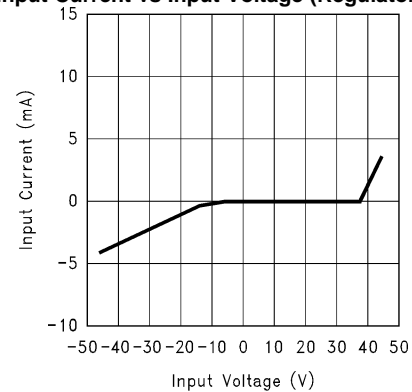

Figure 8.

TYPICAL PERFORMANCE CHARACTERISTICS (continued)

($T_A = 25^\circ\text{C}$ unless otherwise specified)

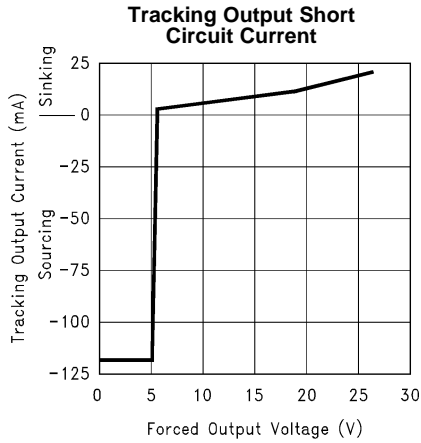

Figure 9.

Main Regulator Dropout Voltage vs Load Current

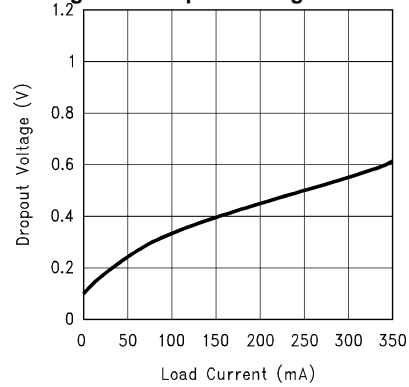

Figure 10.

Output Short Circuit Current vs Temperature

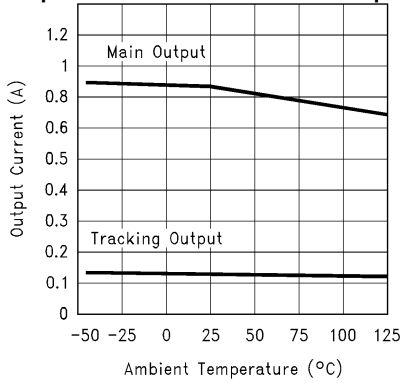

Figure 11.

Reverse Battery Input Current

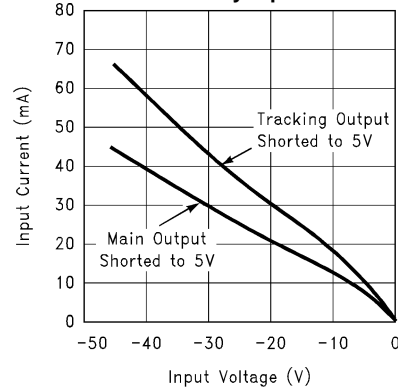

Figure 12.

Maximum Power Dissipation

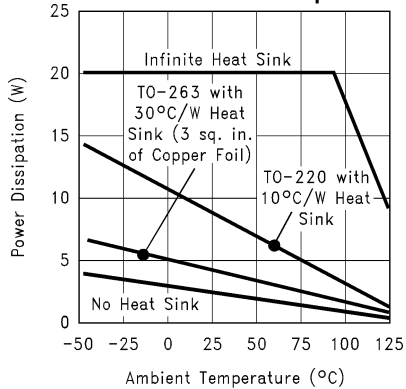

Figure 13.

Output Capacitor ESR

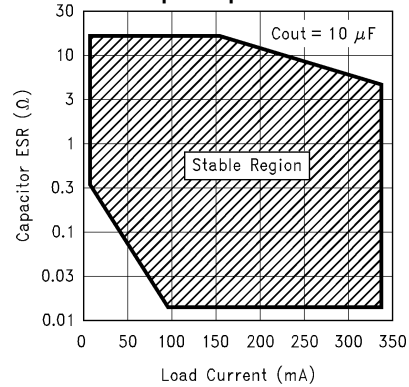

Figure 14.

OPERATIONAL CHARACTERISTICS

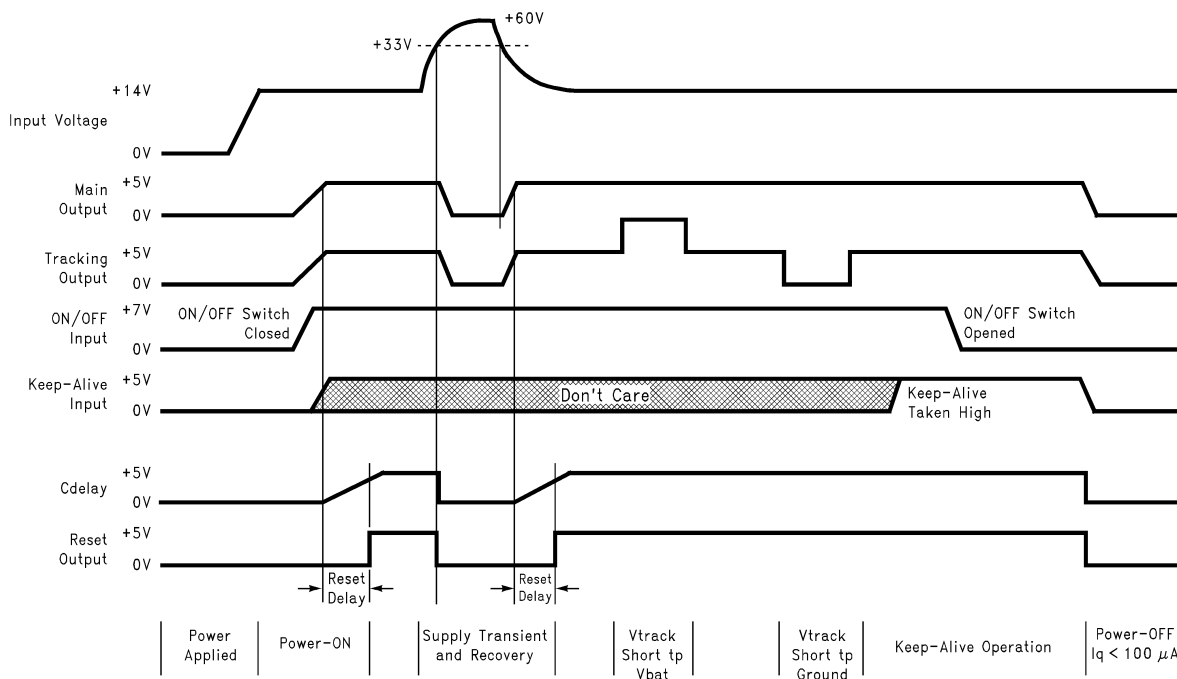

Table 1. Control Logic Truth Table

ON/OFF Input	Keep-Alive Input	Main Output Voltage	Tracking Output Voltage	Reset Output	Operating Condition
L	L	0V	0V	0V	OFF, Input Current < 100 μA
↑	L	5V	5V	↑ After Delay	Outputs Turn ON, Power ON Delayed Reset
H	X	5V	5V	5V	Normal ON Condition
H	X	< 4.45V	< 4.45V	0V	Main Output Pulled Out of Regulation, Reset Flag Generated
↓	H	5V	5V	5V	Keep-Alive, Continued Normal Operation
L	↑	5V	5V	↑ After Delay	Outputs Turned ON by Keep-Alive Input

APPLICATION INFORMATION

PIN DESCRIPTION AND FUNCTIONALITY

The LM9072 is a precision dual tracking voltage regulator optimized for use in powertrain module applications but will also find use in a wide variety of automotive and industrial applications where precision supply regulation is required in harsh operating environments. The following will describe the functionality of each of the package pins.

INPUT VOLTAGE (Pin 3)

The LM9072 has been designed to connect directly to the ignition or battery supply in automotive applications. For this type of supply the regulator has been designed to withstand up to +60V and –45V supply transients such as load dump. An overvoltage shut down protection scheme turns OFF both of the regulator outputs should supply transients exceed typically +33V to fully protect all load circuitry. This higher threshold allows normal operation with 24 V_{DC} applied to the input as in the event when two batteries are used to start a vehicle. Protection of the system is also provided for inadvertent reverse polarity battery connections.

The current drain on the supply line is directly proportional to the load currents on the two voltage regulators. With no load current on either output the regulator requires 15 mA maximum quiescent current for biasing internal circuitry. During dropout conditions (V_{IN} < 5.5V) the additional input current can rise to 50% of the total load current. With less than 4V applied to the input, internal biasing circuitry shuts OFF.

When *switched* OFF the regulator can remain connected to the battery supply with a current drain of less than 100 μ A.

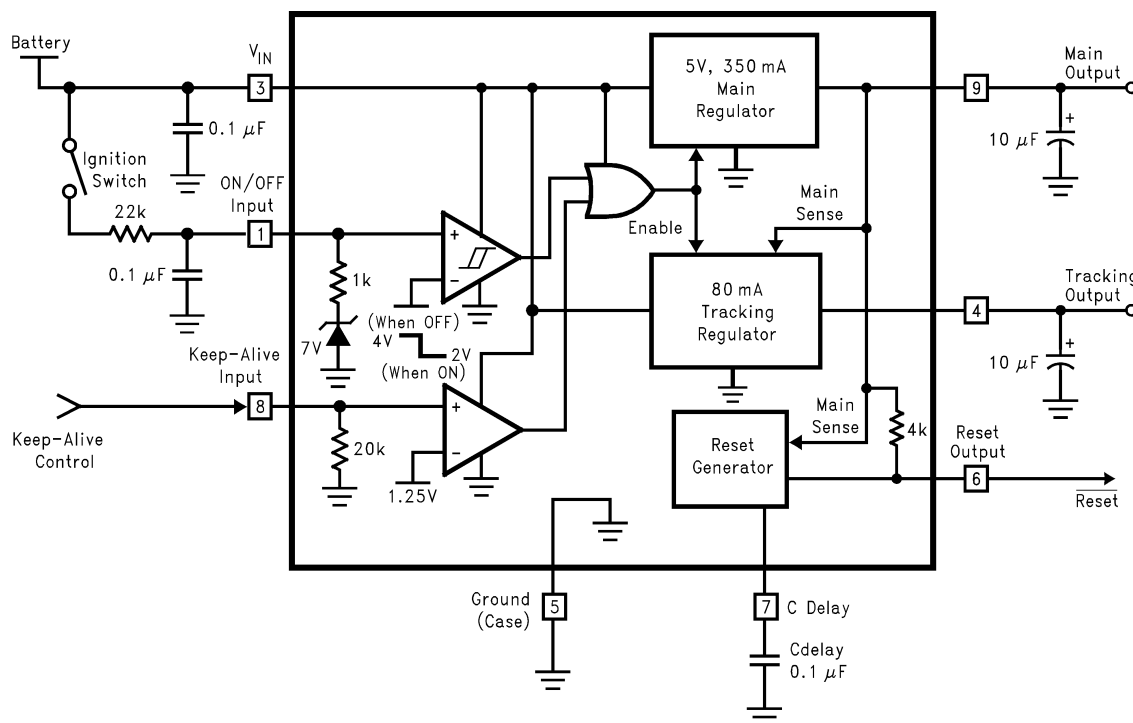

Figure 15. Circuit Block Diagram

MAIN OUTPUT (Pin 9)

The Main Output regulator provides a well controlled (3% tolerance maximum) 5V supply line with a total load current ranging up to 350 mA. This relatively high level of output current is sufficient to provide power to a large number of load circuits in a variety of module applications.

This output has a short to ground current limit between 500 mA and 1A. The Main output can also withstand a short circuit to potentials up to 7V.

To maintain stability of this supply line an output bypass capacitor is required. This capacitor must be at least 6 μF with an equivalent series resistance (ESR) between 0.3 Ω and 3 Ω over temperature.

The Main Output is sensed for the generation of the system reset output. Feedback from the Main Output is also used to control the output voltage of the tracking regulator.

TRACKING OUTPUT (Pin 4)

The Tracking Output regulator is a key feature of the LM9072. This output provides a voltage that directly tracks the main output voltage within 1.5%. This 80 mA output is provided to bias sensors and other devices located external to the main system module.

For providing remote power the Tracking Output is fully protected against short circuit connections to the battery or input supply (up to 27V) and to ground. These shorted fault conditions do not affect the operation of the main supply nor generate a reset of the system.

The tracking characteristic allows for ratiometric operation of sensors by providing power that is directly proportional to the system supply. Similar to the main output a bypass capacitor is required for stability. This capacitor should also be greater than 6 μF with an ESR between 0.3 Ω and 3 Ω .

RESET OUTPUT (Pin 6)

The Reset Output is an active low logic signal provided to reset a system microcontroller on power up and in the event that the Main Output supply falls out of regulation. This output is ensured to provide a logic low level (< 0.4V) whenever the Main Output supply is below 4.45V or is pulled above 5.75V. This general reset prevents erratic system operation which may occur with out-of-specification supply potentials.

The Reset Output has an active pull down to ground and a passive pull-up (through a 4 k Ω resistor) to the Main Output to ensure voltage compatibility with the system supply. Capacitive loading on this reset line will directly affect the rise time of the reset signal. The Reset Output will maintain a logic low level with a Main Output voltage of only 1V. Below 1V the active pull-down device switches OFF (sink current of only 500 μA), but with such a low supply potential, system controllers are generally inoperative.

The Reset Output has a built-in delay time interval which is programmable by the selection of the delay capacitor.

DELAY CAPACITOR (Pin 7)

The Delay Capacitor (C_{DELAY}) controls a time interval that the Reset Output remains low after the Main Output has established normal operating condition. This feature holds the system in reset for a time to allow all load circuitry to be properly biased before executing functions. This interval is applied at power-up and following any event that may trigger the system reset function.

Figure 16 illustrates the delayed reset generator. Two comparators continually monitor the Main Output supply. Window comparators C1 and C2 detect if the Main Supply is below 4.6V or exceeds 5.5V typically. If this is true (at power-on, for example) the control logic turns ON the discharge transistor and holds C_{DELAY} low (at 0.9V). Comparator C4 then outputs a logic low system Reset signal within 2 μs after detecting the out of regulation condition.

The Delay Capacitor remains discharged until the window comparator senses that the Main Output is within normal operating range (C1 and C2 outputs are both low). When this condition is met, the discharge transistor is turned OFF and C_{DELAY} is charged positively by an internal 6 μA current source. The Reset Output will remain low until the delay capacitor has reached 4V, at which point it will go high and the system will begin normal operation. This delay time interval is controlled by the selection of C_{DELAY} and can be determined from the following equation:

$$T_{\text{DELAY}} = (0.5 \times 10^6) \cdot C_{\text{DELAY}} \quad (1)$$

Typically a 0.1 μF capacitor will produce a delay interval of 50 ms.

To ensure a consistent delay time interval, the discharge transistor is always latched ON by the window comparators, and can not be switched OFF to start a new delay interval until C_{DELAY} has been discharged to less than or equal to 0.9V. This sets a fixed starting voltage (0.9V) and ending voltage (4V) for the charging of the Delay Capacitor.

ON/OFF INPUT (Pin 1)

The ON/OFF Input enables both the Main and Tracking outputs. In a typical application this input is connected to the input supply through a series resistor (nominally 22 k Ω) and a switch (Ignition, as an example). When the switch is closed this input is pulled high and switches ON both regulator outputs. This input is internally clamped to a 7V zener diode through a series 1 k Ω resistor. The external series resistor together with an optional 0.1 μ F capacitor to ground are optional to provide filtering and current limiting to withstand any transients that may appear on the input supply in order to maintain normal operation of the system.

The switching threshold of the ON/OFF comparator has 2V of hysteresis to ensure noise free control of the system. To turn the regulators ON this input must be taken above 4V. To turn the system OFF the ON/OFF Input must be open circuited or taken below 2V.

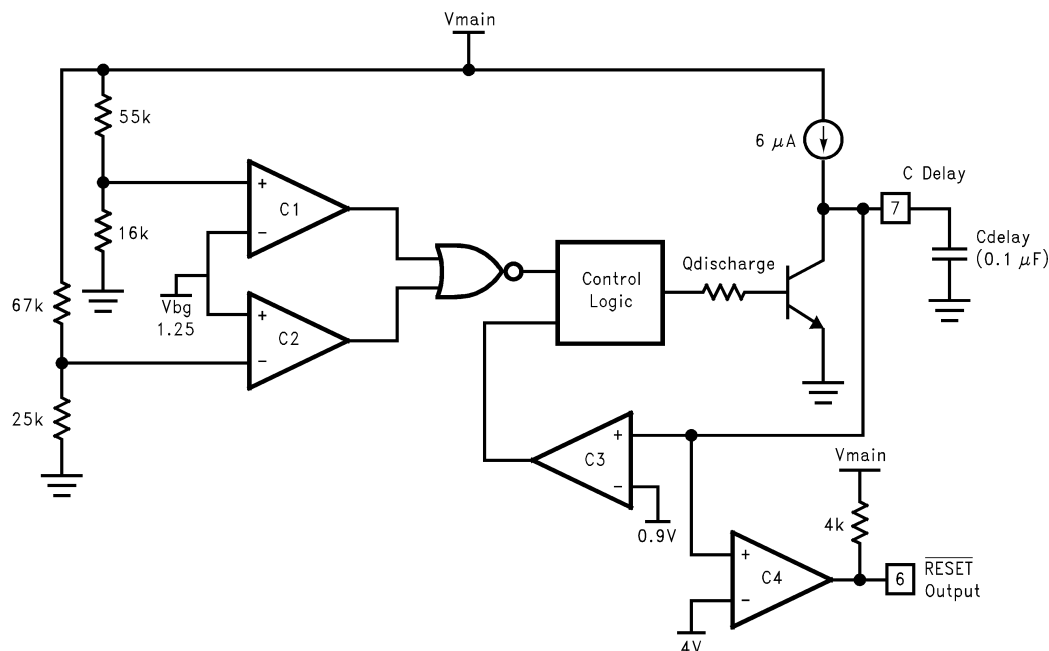

Figure 16. Reset Generator

KEEP-ALIVE INPUT (Pin 8)

This CMOS logic level compatible input provides a system with the ability to control its own ON/OFF sequencing. The Keep-Alive Input is OR'ed with the ON/OFF Input so either one can independently control the regulators.

As shown in the Operational Characteristics a system controller can take the Keep-Alive input high at any time. If the ON/OFF switch is opened, this high level on Keep-Alive will keep the regulators ON and the entire system operational. This control is useful for providing as much time as necessary for a system to perform "housekeeping" chores such as programming EEPROM with system information prior to turning itself OFF (by taking the Keep-Alive Input low) and reverting to the low quiescent current state.

A second use of the Keep-Alive Input can be from other modules which need information from the module powered by the LM9072, [Figure 17](#). A CMOS logic high level (> 2V) on this input will power up the system as needed independent from the normal ON/OFF switch.

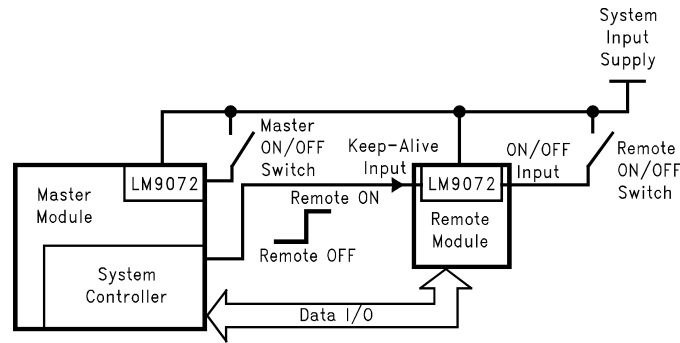

Figure 17. Remote ON/OFF Control

SYSTEM KEEP-ALIVE OPERATION

Figure 18 illustrates the basic concept of Keep-Alive operation. The LM9072 provides regulated supplies to an entire microcontroller based system or module including remote sensors. The system is switched ON or OFF by a switch connected to the unregulated input supply and the ON/OFF input, pin 1. When closed the regulators turn ON and the system is held in a reset state for the duration of the delayed reset interval controlled by C_{DELAY} .

Once normal operation of the system begins, the controller needs to set an output line connected to the Keep-Alive input, pin 8, high. The system remains in normal operation until switched OFF by opening the ON/OFF switch. With Keep-Alive high the entire system remains normally biased and will remain operational until the Keep-Alive input is taken low.

Transistor Q1 is shown as a means to inform the controller that the ON/OFF switch has been opened. This high level on an input line tells the controller that the system has been switched OFF. This indicates the start of the Keep-Alive interval. The system can perform whatever actions required to obtain the proper OFF state before actually powering down. These general housekeeping tasks can include putting external devices in the proper OFF condition and storing various system variables in EPROM for example. With the controller in command of the Keep-Alive interval these tasks can take whatever time necessary to complete.

When completed the controller takes the Keep-Alive input to a low level and the entire system shuts down. The LM9072 powers down to a low quiescent current mode with less than 100 μ A drawn from the input supply.

To initiate the Keep-Alive routine before actual power down, it is important for the system controller to know when the system has been switched OFF. To eliminate any interface between the controller and the ON/OFF switch and potentially noisy unregulated input supply, a simple logic scheme shown in Figure 19 can be used. With this circuitry the Reset output from the LM9072 provides the ON/OFF sensing input to the controller.

When switched OFF, the main regulator output will fall out of regulation and generate a low logic level on the Reset output. This input to the controller provides the switch OFF indication and initiates the Keep-Alive interval.

Control of the Keep-Alive duration is set by a logic 1 on the Keep-Alive output line from the system controller. This high level prevents the Reset output from resetting the entire system and also gates the Keep-Alive input signal to the LM9072. The inverted Reset signal provides a logic 1 to the Keep-Alive input of the LM9072.

The Main output will only drop out of regulation for a very short time before the Keep-Alive input turns it back on.

The Reset output remains low for the delay time interval. When it returns high the Main output switches OFF and back ON again very quickly. This continues until the system controller takes the Keep-Alive output line to a logic low level.

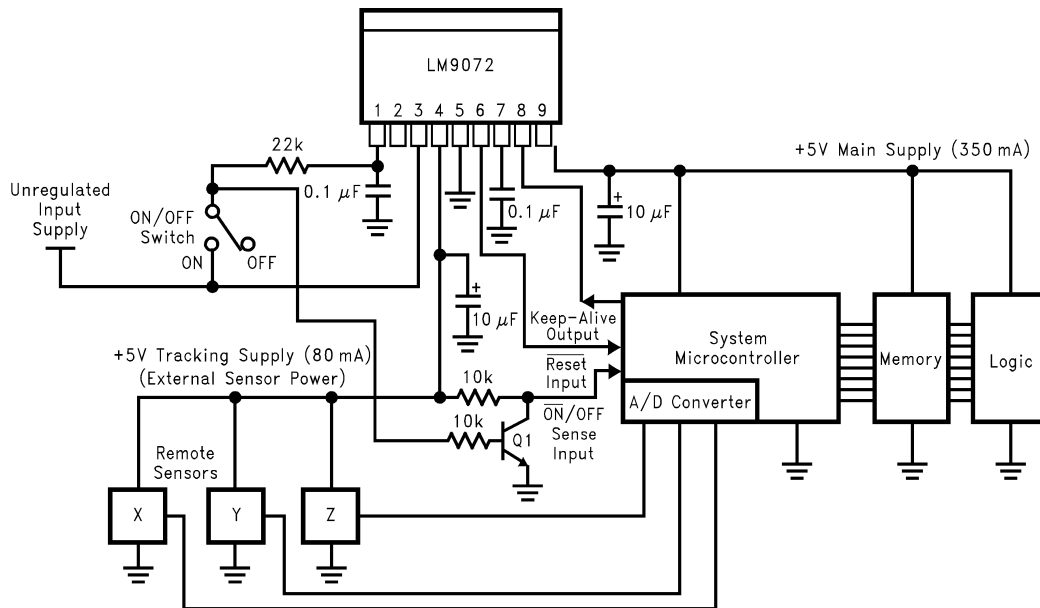

Control Waveforms

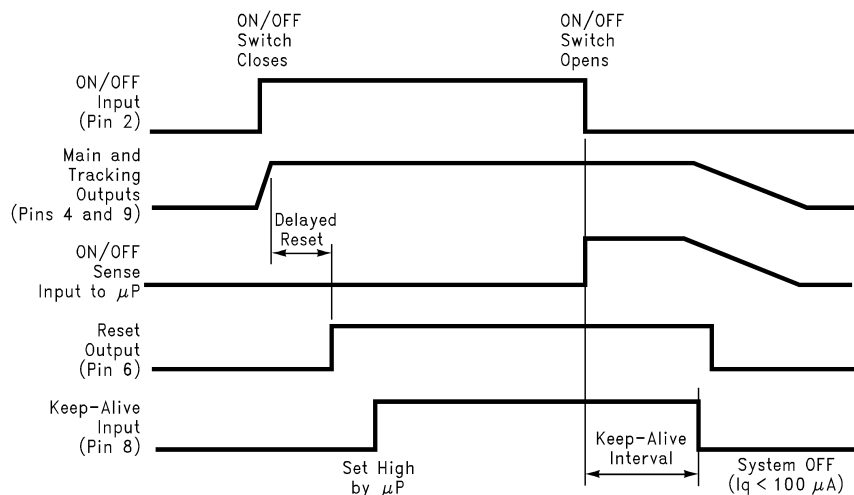

Figure 18. Basic Keep-Alive Operation

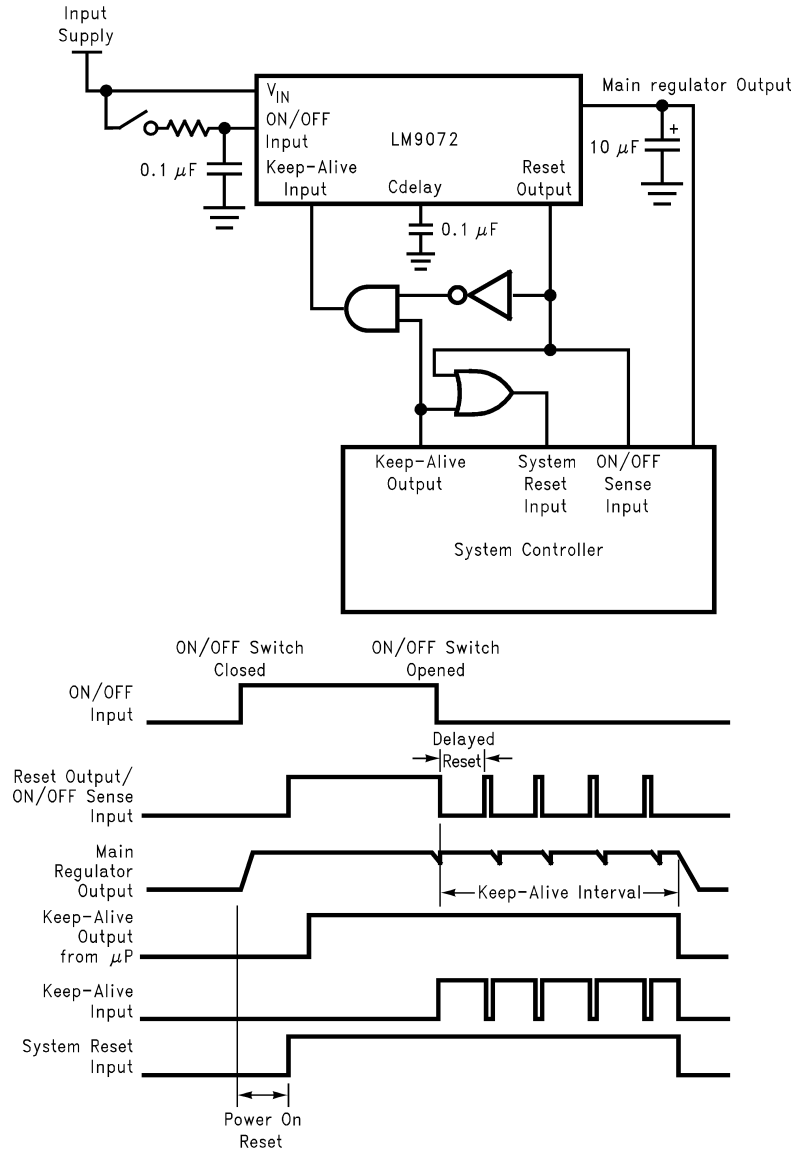

Figure 19. Simple Logic Configuration to Provide ON/OFF Sensing

SAFETY LATCH-OFF

To address a system FMEA (Failure Mode Effects Analysis) issue the Keep-Alive high level should be derived from the Tracking output regulator as shown in Figure 20. The issue stems from the “what-if” scenario whereby the system is in the Keep-Alive state and there is a short to ground on the Tracking Output regulator. If this output is powering remote sensors or systems, this becomes a more highly possible fault condition. Since a short on the Tracking output does not affect the Main output, which, if used to provide the Keep-Alive input signal, would remain ON and draw 120 mA, the short circuit current of the Tracking regulator, from the input supply.

Using the Tracking output supply for Keep-Alive would prevent Keep-Alive operation during a short to ground fault and the excessive drain on the input supply. The inversion by the transistor will require a low level from the controller to allow Keep-Alive operation. The 24 kΩ pull-up resistor provides current limiting in the event of a Tracking output short to the unregulated/battery input supply.

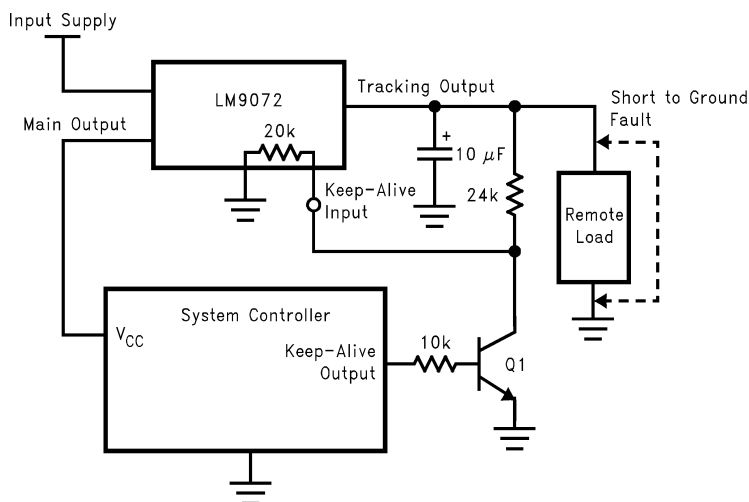

Figure 20. Safety Latch-OFF

INPUT STABILITY

Low dropout voltage regulators which utilize a PNP power transistor usually exhibit a large increase in current when in dropout ($V_{IN} < 5.5V$). This increase is caused by the saturation characteristics (β reduction) of the PNP transistor. To significantly minimize this increase in current the LM9072 detects when the PNP enters saturation and reduces the operating current.

This reduction in input current can create a stability problem in applications with higher load current (> 200 mA) where the input voltage is applied through a long length of wire which in effect add a significant amount of inductance in series with the input. The drop in input current may create a positive input voltage transient which may take the PNP out of saturation. If the input voltage is held constant at the threshold where the PNP is going in and out of saturation, an oscillation may be created.

This is only observed where a large series inductance is present in the input supply line and when the rise and fall time of the input supply is very slow. If the application and removal of the input voltage changes at a rate greater than 500 mV/ms it will move through the dropout region of the regulator (V_{IN} of 3V to 5.5V) too quickly for an oscillation to be established.

In the event that an oscillation is present, input bypassing can also help de-tune the resonance. [Figure 21](#) illustrates two input bypassing approaches. The straightforward addition of a larger valued electrolytic capacitor could suffice. In this case however, if reverse battery connections are a possibility it is necessary to add a series protection diode as shown to prevent damaging the polarized input capacitor.

An alternative input bypassing scheme is also shown. This eliminates the use of polarized input capacitors and a series protection diode. The values shown were derived empirically in a representative typical application. Appropriate values for any given application require experimentation.

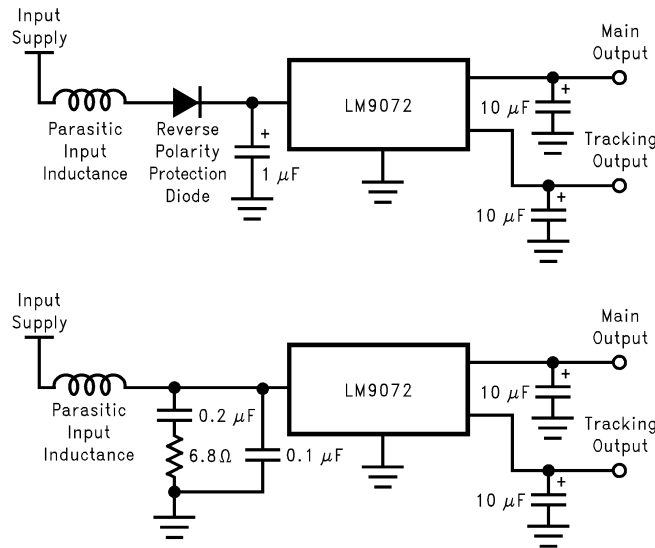

Figure 21. Input Bypassing

THERMAL MANAGEMENT

The LM9072 is packaged in both a SFM surface mount power package and a narrow lead-pitch TO-220 package. To obtain operation over the highest possible load current and input voltage ranges, care must be taken to control the operating temperature of the device. Thermal shutdown protection is built in, with a threshold above 150°C. Conventional heat-sinking techniques can be used with the TO-220 package. When applying the SFM package, on board heat-sinking is important to prevent premature thermal shutdown. More copper foil area under the tab of the device will directly improve the operating θ_{J-A} of the SFM package, which will reduce the junction temperature of the device.

The θ_{J-A} value for the SFM package (still air, no additional heat sink) is rated at 80°C/W. The effective θ_{J-A} value of the SFM package can be reduced by increasing the printed circuit board area that is connected (soldered) to the package tab. Using 1 ounce (1.4 mils thick) copper clad with no solder mask, an area of 0.5 square inches will reduce θ_{J-A} to 50°C/W, an area of 1.0 square inches will reduce θ_{J-A} to 37°C/W, and an area of 1.6 square inches will reduce θ_{J-A} to 32°C/W. If the printed circuit board uses a solder mask, the copper clad area under the solder mask should be increased by at least 50% to maintain a similar θ_{J-A} rating.

The use of a double sided PC board with soldered filled vias between two planes of copper, as shown in [Figure 22](#), will improve thermal performance while optimizing the PC board surface area required. Using the double sided PC board arrangement shown in [Figure 22](#), with 1 ounce (1.4 mils thick) copper clad with no solder mask and solder filled vias, an area of 0.5 square inches on both sides will reduce θ_{J-A} to 43°C/W.

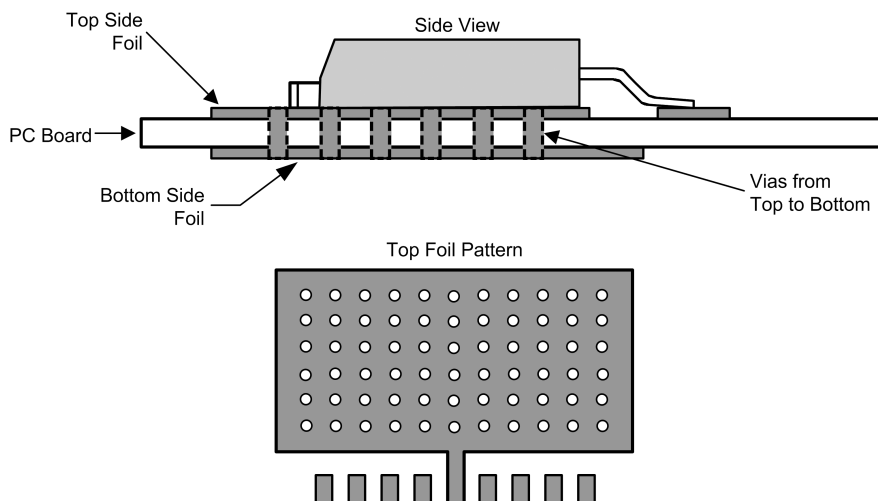

Figure 22. Typical SFM PC Board Heatsinking

ELECTRO-MAGNETIC COMPATIBILITY (EMC)

The LM9072 offers good immunity to high frequency interference in a standard Bulk Current Injection (BCI) test (ISO11452 Part 4 test method). The following test conditions and configuration (Figure 23) can be used to observe this performance.

Frequency Range	1 MHz to 400 MHz
Modulation 1	CW (no modulation)
Modulation 2	1 kHz sine wave, 80% AM
Dwell Time	1 second
Frequency Steps	1 MHz (from 1 MHz to 10 MHz)
	2 MHz (from 10 MHz to 200 MHz)
	20 MHz (from 200 MHz to 400 MHz)
Test Method	Closed loop current probe

In this test configuration the current injected into either the input pin or the tracking output pin is increased until a reset output is generated. These two pins are the most critical as they typically will connect to a module through long lengths of wire most likely to pick up high frequency energy. Figure 24 illustrates examples of test results on the LM9072 with both types of modulation.

These results are just examples as actual results in any given application will depend on numerous external factors such as component selection, pc board layout, etc. The current power of the injected signal is expressed in dB relative to 1 mA (i.e., 40 dBmA = 100 mA).

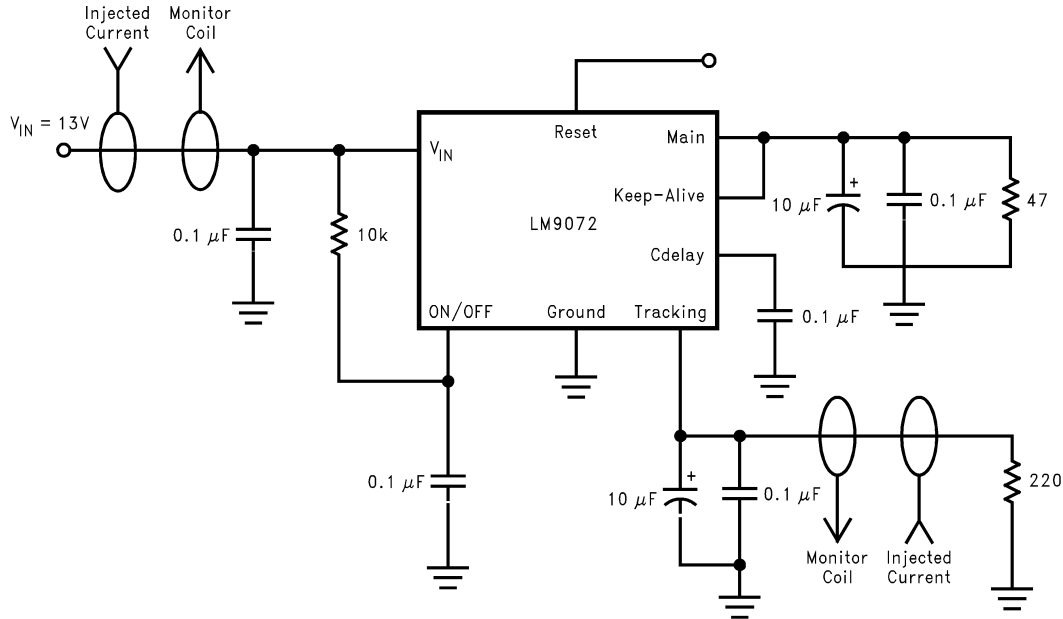

Figure 23. Bulk Current Injection Test Configuration

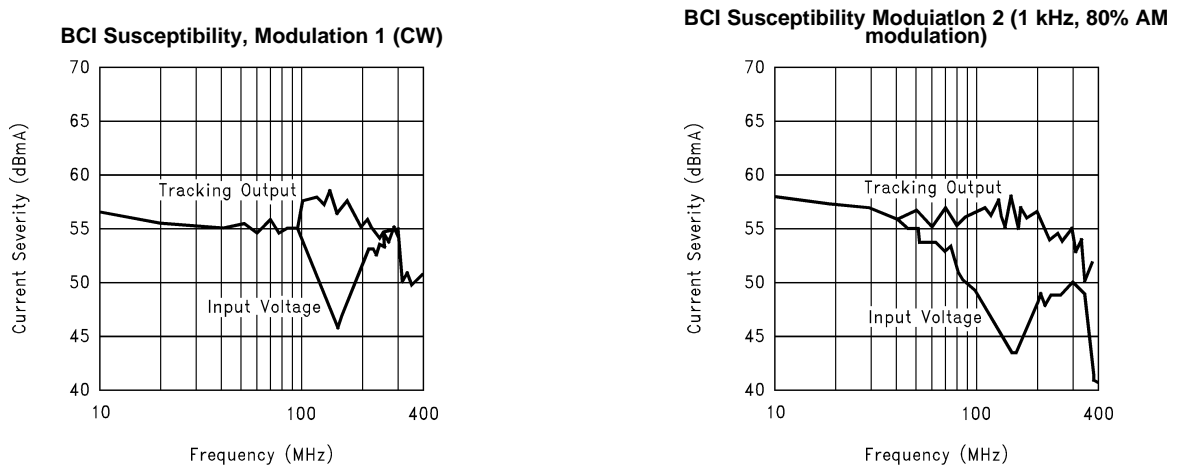

Figure 24. Examples of BCI Test Results

REVISION HISTORY

Changes from Revision C (April 2013) to Revision D	Page
• Changed layout of National Data Sheet to TI format	17

IMPORTANT NOTICE

Texas Instruments Incorporated and its subsidiaries (TI) reserve the right to make corrections, enhancements, improvements and other changes to its semiconductor products and services per JESD46, latest issue, and to discontinue any product or service per JESD48, latest issue. Buyers should obtain the latest relevant information before placing orders and should verify that such information is current and complete. All semiconductor products (also referred to herein as "components") are sold subject to TI's terms and conditions of sale supplied at the time of order acknowledgment.

TI warrants performance of its components to the specifications applicable at the time of sale, in accordance with the warranty in TI's terms and conditions of sale of semiconductor products. Testing and other quality control techniques are used to the extent TI deems necessary to support this warranty. Except where mandated by applicable law, testing of all parameters of each component is not necessarily performed.

TI assumes no liability for applications assistance or the design of Buyers' products. Buyers are responsible for their products and applications using TI components. To minimize the risks associated with Buyers' products and applications, Buyers should provide adequate design and operating safeguards.

TI does not warrant or represent that any license, either express or implied, is granted under any patent right, copyright, mask work right, or other intellectual property right relating to any combination, machine, or process in which TI components or services are used. Information published by TI regarding third-party products or services does not constitute a license to use such products or services or a warranty or endorsement thereof. Use of such information may require a license from a third party under the patents or other intellectual property of the third party, or a license from TI under the patents or other intellectual property of TI.

Reproduction of significant portions of TI information in TI data books or data sheets is permissible only if reproduction is without alteration and is accompanied by all associated warranties, conditions, limitations, and notices. TI is not responsible or liable for such altered documentation. Information of third parties may be subject to additional restrictions.

Resale of TI components or services with statements different from or beyond the parameters stated by TI for that component or service voids all express and any implied warranties for the associated TI component or service and is an unfair and deceptive business practice. TI is not responsible or liable for any such statements.

Buyer acknowledges and agrees that it is solely responsible for compliance with all legal, regulatory and safety-related requirements concerning its products, and any use of TI components in its applications, notwithstanding any applications-related information or support that may be provided by TI. Buyer represents and agrees that it has all the necessary expertise to create and implement safeguards which anticipate dangerous consequences of failures, monitor failures and their consequences, lessen the likelihood of failures that might cause harm and take appropriate remedial actions. Buyer will fully indemnify TI and its representatives against any damages arising out of the use of any TI components in safety-critical applications.

In some cases, TI components may be promoted specifically to facilitate safety-related applications. With such components, TI's goal is to help enable customers to design and create their own end-product solutions that meet applicable functional safety standards and requirements. Nonetheless, such components are subject to these terms.

No TI components are authorized for use in FDA Class III (or similar life-critical medical equipment) unless authorized officers of the parties have executed a special agreement specifically governing such use.

Only those TI components which TI has specifically designated as military grade or "enhanced plastic" are designed and intended for use in military/aerospace applications or environments. Buyer acknowledges and agrees that any military or aerospace use of TI components which have **not** been so designated is solely at the Buyer's risk, and that Buyer is solely responsible for compliance with all legal and regulatory requirements in connection with such use.

TI has specifically designated certain components as meeting ISO/TS16949 requirements, mainly for automotive use. In any case of use of non-designated products, TI will not be responsible for any failure to meet ISO/TS16949.

Products

Audio	www.ti.com/audio
Amplifiers	amplifier.ti.com
Data Converters	dataconverter.ti.com
DLP® Products	www.dlp.com
DSP	dsp.ti.com
Clocks and Timers	www.ti.com/clocks
Interface	interface.ti.com
Logic	logic.ti.com
Power Mgmt	power.ti.com
Microcontrollers	microcontroller.ti.com
RFID	www.ti-rfid.com
OMAP Applications Processors	www.ti.com/omap
Wireless Connectivity	www.ti.com/wirelessconnectivity

Applications

Automotive and Transportation	www.ti.com/automotive
Communications and Telecom	www.ti.com/communications
Computers and Peripherals	www.ti.com/computers
Consumer Electronics	www.ti.com/consumer-apps
Energy and Lighting	www.ti.com/energy
Industrial	www.ti.com/industrial
Medical	www.ti.com/medical
Security	www.ti.com/security
Space, Avionics and Defense	www.ti.com/space-avionics-defense
Video and Imaging	www.ti.com/video

TI E2E Community

e2e.ti.com

Looking for pricing, stock, or lifecycle information?

Click below to explore more details on WIN SOURCE:

 [View LM9072S](#) on WIN SOURCE

 [Texas Instruments](#) Information

Optimize Your Supply Chain with WIN SOURCE Solutions

-  Global Sourcing Solution
-  Obsolete Management
-  Cost Control Management
-  Shortage Management
-  Alternative Solution
-  Excess Inventory Management